

INSTRUCTION MANUAL

INSTALLATION, COMMISSIONING & SERVICING

FLOOR STANDING OIL FIRED CONDENSING COMBINATION BOILER

CONVENTIONAL FLUE & ROOM SEALED FLUE

GREENSTAR HEATSLAVE

12/18, 18/25 & 25/32

FOR OPEN VENT & SEALED CENTRAL HEATING SYSTEMS WITH
MAINS FED DOMESTIC HOT WATER

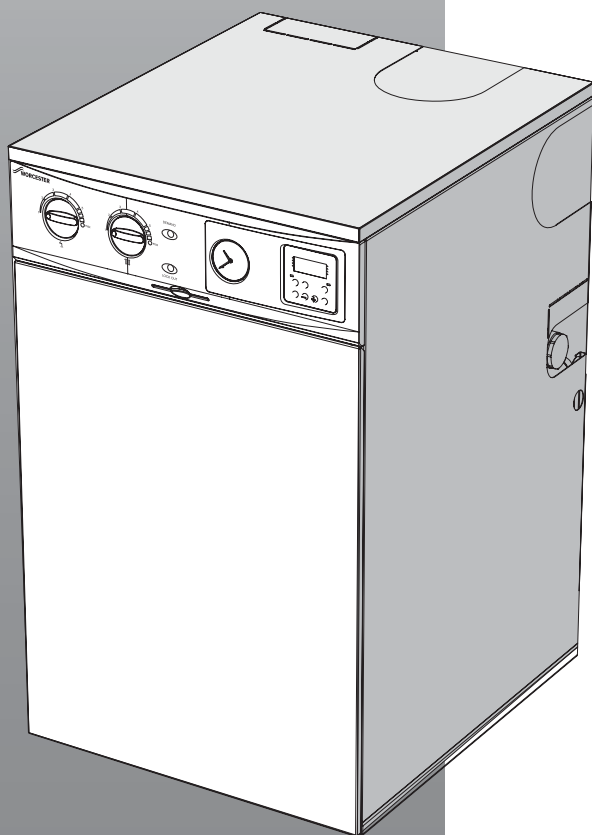

THE APPLIANCE IS FOR USE WITH KEROSENE
(28 SECOND OIL) ONLY

UK

WORCESTER
Bosch Group

INSTALLATION & SERVICING INSTRUCTIONS

SYMBOLS USED IN THIS MANUAL:



Domestic hot water



Central heating



Room thermostat



Frost thermostat



Wait time period



Programmer/timer OFF

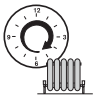

Programmer ON CH only



Programmer ON DHW only

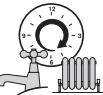

Programmer ON CH and DHW



Cold water main supply



Electricity supply

IMPORTANT HANDLING INSTRUCTIONS:

It is advised that more than one person is involved in the transfer of the packaged appliance from the van to the point of installation. It is advised that no attempt should be made to move the packaged appliance without the use of a suitable truck.

At all times the correct method for handling heavy objects should be strictly observed.

GENERAL HANDLING GUIDELINES:

- Lift only a manageable weight, or ask for help.
- When lifting, bend the knees, and keep the back straight and feet apart.
- Do not lift and twist at the same time.
- Lift and carry items close to the body.
- Wear protective clothing and gloves to protect from any sharp edges.

PLEASE READ THESE INSTRUCTIONS CAREFULLY BEFORE STARTING INSTALLATION.

THESE INSTRUCTIONS ARE APPLICABLE TO THE WORCESTER APPLIANCE MODEL(S) STATED ON THE FRONT COVER OF THIS MANUAL ONLY AND MUST NOT BE USED WITH ANY OTHER MAKE OR MODEL OF APPLIANCE.

THE INSTRUCTIONS APPLY IN THE UK AND EIRE ONLY AND MUST BE FOLLOWED EXCEPT FOR ANY STATUTORY OBLIGATION.

THIS APPLIANCE MUST BE INSTALLED BY A COMPETENT PERSON. FAILURE TO INSTALL CORRECTLY COULD LEAD TO PROSECUTION.

COMPLYING WITH THE BUILDING REGULATIONS:

This heating appliance forms part of the controlled services for the building. It is law that all controlled services for buildings must comply with building regulations. You must be able to satisfy your Local Authority Building Control Body (LABC) that the work carried out concerning the installation and commissioning of this heating appliance has been carried out to a satisfactory standard.

OFTEC operate a competent persons scheme and registered installers are able to certify that their work complies with building regulations. Under the scheme;

- OFTEC must be informed about every installation.
- OFTEC will issue a building regulations compliance certificate to the householder and will notify the LABC.

OFTEC provide controlled document forms CD10 and CD11 for use during installation and commissioning respectively.

Other organisations operate self-certification schemes e.g. NAPIT and BESCA Ltd. and it may be possible for installers who are members of these organisations to self certify their work.

Alternatively you must submit a building control notice to the LABC before installing any boiler. The LABC will then arrange regular inspection visits during the work to ensure that the installation complies with the regulations.

IF YOU ARE IN **ANY DOUBT** CONTACT THE WORCESTER TECHNICAL HELPLINE.

DISTANCE LEARNING AND TRAINING COURSES ARE AVAILABLE FROM WORCESTER.

PLEASE LEAVE THESE INSTRUCTIONS WITH THE COMPLETED COMMISSIONING FORM AND THE USER MANUAL WITH THE OWNER OR WITH THE APPLIANCE AFTER INSTALLATION OR SERVICING. THE SERVICE INTERVAL RECORD CAN BE FOUND ON THE BACK PAGE OF THIS MANUAL.

ABBREVIATIONS USED IN THIS MANUAL:

∅	Diameter
CH	Central Heating
DHW	Domestic Hot Water
DCW	Domestic Cold Water
TRV	Thermostatic Radiator Valve
IP	Ingress Protection
CF	Conventional flue
BF	Balanced flue
N/A	Not allowed
SEDBUK	Seasonal Efficiency of Domestic Boilers in the United Kingdom
OFTEC	Oil Firing Technical Association for the Petroleum Industry
IEE	Institute of Electrical Engineers
LABC	Local Authority Building Control Body

STORE THE APPLIANCE IN A DRY AREA PRIOR TO INSTALLATION.

WATER TREATMENT:

FERNOX	01799 550811 fernox.com
SENTINEL	0800 389 4670 sentinel-solutions.net

FLUE TERMINAL GUARD: Part No. 7 716 190 050

CONTENTS

SAFETY & REGULATIONS

IMPORTANT INFORMATION AND SYMBOLS	2
SAFETY PRECAUTIONS AND INSTALLATION REGULATIONS	4

APPLIANCE INFORMATION

GENERAL INFORMATION	5
TECHNICAL DATA	6
LAYOUT & COMPONENTS	7

PRE-INSTALLATION

CLEANING PRIMARY SYSTEMS	8
MAINS SUPPLY	9
OIL SUPPLY	10
WATER SYSTEMS & PIPEWORK	11
PRESSURE RELIEF PIPEWORK	12
CONDENSATE PIPEWORK	13
BOILER LOCATION & CLEARANCES	14
FLUE TERMINAL POSITIONS	16
CONVENTIONAL FLUE	17
ROOM SEALED FLUE OPTIONS	18

INSTALLATION

UNPACKING THE BOILER	19
PIPEWORK POSITIONS / FLUE OPENING	20
BOILER INSTALLATION	21
FLUE INSTALLATION	22
COMBUSTION CHAMBER	23
PIPEWORK CONNECTIONS	24
OIL BURNER AND PUMP	25
REFITTING COMPONENTS	26
ELECTRICS	27

COMMISSIONING

PRE-COMMISSIONING CHECKS - APPLIANCE	29
FILLING THE SYSTEM	30
STARTING THE APPLIANCE	31
WATER TREATMENT	36
FINISHING COMMISSIONING - APPLIANCE	37

SERVICING & SPARES

INSPECTION AND SERVICE	38
SHORT PARTS LIST BENTONE STERLING 40 - 12/18	43
SHORT PARTS LIST BENTONE STERLING 50 - 18/25	44
SHORT PARTS LIST RIELLO RDB 1 - 12/18	45
SHORT PARTS LIST RIELLO RDB 2.2 - 18/25	46
SHORT PARTS LIST RIELLO RDB 2.2 - 25/32	47

FAULT FINDING & DIAGNOSIS

FAULT FINDING	48
RIELLO CONTROL BOX OPERATION	50
FAULT FINDING LOGIC FOR SATRONIC CONTROL BOX	51
FAULT FINDING LOGIC FOR RIELLO CONTROL BOX	52
ELECTRICAL SCHEMATIC	53
COMMISSIONING CHECKLIST	54
SERVICE INTERVAL RECORD	55

SAFETY &
REGULATIONS

APPLIANCE
INFORMATION

PRE -
INSTALLATION

INSTALLATION

COMMISSIONING

SERVICING
& SPARES

FAULT FINDING
& DIAGRAMS

NOTES

SAFETY PRECAUTIONS

OIL FUMES OR LEAKS FROM THE APPLIANCE:

- ✓ Extinguish any naked flames.
- ✓ Open windows and doors.
- ✓ Isolate the electrical supply.
- ✓ Isolate the fuel supply to the boiler.
- ✓ Rectify fault.

HEALTH & SAFETY:

The appliance contains no asbestos and no substances have been used in the construction process that contravene the COSHH Regulations (Control of Substances Hazardous to Health Regulations 1988). Where applicable, the CE mark indicates compliance with relative EU Directives.

COMBUSTIBLE AND CORROSIVE MATERIALS:

Do not store or use any combustible materials (paper, thinners, paints etc.) inside or within the vicinity of the appliance.

The combustion air must be kept clear of chemically aggressive substances which can corrode the appliance and invalidate any warranty.

FITTING & MODIFICATIONS:

Fitting the appliance and any controls to the appliance may only be carried out by a competent engineer in accordance with these instructions and the relevant Installation Regulations.

Flue systems must not be modified in any way other than as described in the fitting instructions. Any misuse or unauthorised modifications to the appliance, flue or associated components and systems could invalidate the warranty. The manufacturer accepts no liability arising from any such actions, excluding statutory rights.

SERVICING:

Advise the user to have the system regularly serviced by a competent, qualified engineer (such as OFTEC registered personnel) using approved spares, to help maintain the economy, safety and reliability of the appliance.

IMPORTANT:

This boiler must only be operated by a responsible adult who has been instructed in, understands and is aware of the boiler's operating conditions and effects.

INSTALLATION REGULATIONS

Failure to install appliances correctly could lead to prosecution.

The appliance should be installed by a competent person. The person installing the appliance should be aware of the Health and Safety at Work Act and take appropriate action to ensure that the regulations are adhered to. In order to give optimum efficiency and trouble free operation the appliance must be commissioned by a qualified OFTEC engineer.

The compliance with a British Standard does not, in itself, confer immunity from legal obligations. In particular the installation of this appliance must be in accordance with the relevant requirements of the following British Standards and regulations in respect of the safe installation of equipment:

BS 5410: part 1: Code of practice for Oil Fired Boilers.

BS 799: part 5: Specification for Oil Storage Tanks.

BS 7593: Code of Practice for treatment of water in domestic hot water central heating systems.

BS 5449: part 1: Specification for forced circulation hot water central heating for domestic premises.

BS 5955: part 8: Specification for the installation of thermoplastic pipes and associated fittings for use in domestic hot and cold water services and heating systems.

BS 7291: Thermoplastic pipes and associated fittings for hot and cold water for domestic purposes and heating installations in buildings.

BS 7074: part 1: Application, selection and installation of expansion vessels and ancillary equipment for sealed water systems.

BS 7671: IEE Wiring Regulations, current edition.

BS 1362: Specification for general purpose fuse links for domestic and similar purposes.

The Building Regulations Part G, Part J and L1 England and Wales; Part F, Part G and Part J Section III Scotland; Part L and Part F Northern Ireland.

Local water company bye-laws.

The Control of Pollution (Oil) Regulations.
OFTEC Standards.

Where no specific instruction is given, reference should be made to the relevant codes of practice.

Installations in Eire (Republic of Ireland)

The Installation must be performed by a competent and suitably trained person in accordance with the following Eire regulations.

Current Building Regulations -
Republic of Ireland

ETCI rules for electrical installation

For further guidance see:

OFTEC Technical book three -

Regional requirements: Republic of Ireland

STANDARD PACKAGE:

A - Floor standing oil fired condensing boiler for open vent and sealed domestic central heating and mains fed hot water.

B - Literature pack.

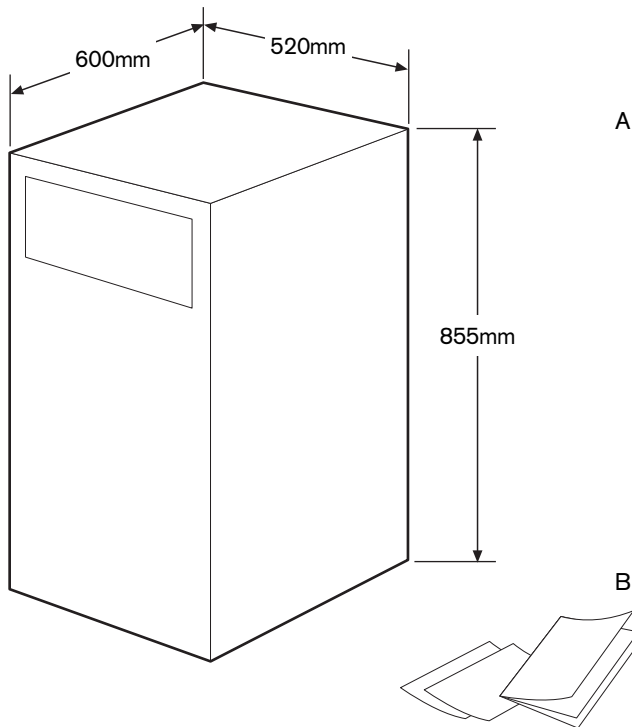

APPLIANCE
INFORMATION

Check List

Hardware/Literature pack

Item	Qty
Greenstar Heatslave Installation/Serviceing Instructions.....	1
Users Instructions	1
Fascia Information Card.....	1
Flue Trim	1
Top Panel Inset Plate.....	1
Edge Clips	1
Warranty Return Envelope	1

TECHNICAL DATA

DESCRIPTION	UNITS	12/18	18/25	25/32
Central Heating				
Primary water capacity (total)	litres	69	69	72
Maximum static head	metres	30	30	30
Minimum static head	metres	1	1	1
Available pump head (20°C difference) at max. output	metres water	4.7	4.0	4.2
Max. permissible sealed system operating pressure in accordance with WRAS guidelines	bar	2.5	2.5	2.5
Flow restrictor	colour	Lime	–	–
Domestic Hot Water				
Maximum flow rate (±15%)	litres/min	15	18	22
Minimum inlet pressure (dynamic) for maximum flow rate	bar	1.5	1.2	0.9
Maximum hot water temperature rise for 90 litres draw off (@max flow rate)	°C	40	40	40
Flue				
Exit flue gas mass flow	kg/hr	29	40	51
Pipework connections				
Fuel line (compression)	mm	10	10	10
CH flow	mm	22	22	28
CH return	mm	22	22	28
Water main inlet	mm	15	15	15
DHW outlet	mm	22	22	22
Combined feed and expansion and open vent (optional)	inch BSP	1	1	1
CH drain	hose connection			
Condensate (polypropylene)	mm	21.5	21.5	21.5
Electrical				
Electrical power supply voltage	AC...V	230	230	230
Frequency	Hz	50	50	50
Max. power consumption	W	240	240	263
Thermostats				
CH control thermostat range (cut in/cut out)	°C	55/81	55/81	55/81
DHW control thermostat range (cut in/cut out)	°C	55/72	55/72	55/72
CH & DHW control thermostat differential	°C	5	5	5
Boiler high limit thermostat set point	°C	92	92	92
Boiler manual reset overheat thermostat set point	°C	105	105	105
Flue reset overheat thermostat set point	°C	110	110	110
Tank manual reset overheat thermostat set point	°C	94	94	94
General Data				
Maximum hearth temperature	°C	<100	<100	<100
SEDBUK (Band A)	%	90.2	90.1	90.3
Appliance protection rating (with programmer blanking plate fitted)	IP	20	20	20
Appliance protection rating (with fascia programmer fitted)	IP	20	20	20
Weight (excluding packaging)	kg	177	177	179

LAYOUT & COMPONENTS

The diagram opposite excludes the top, front and RH side casing panels.

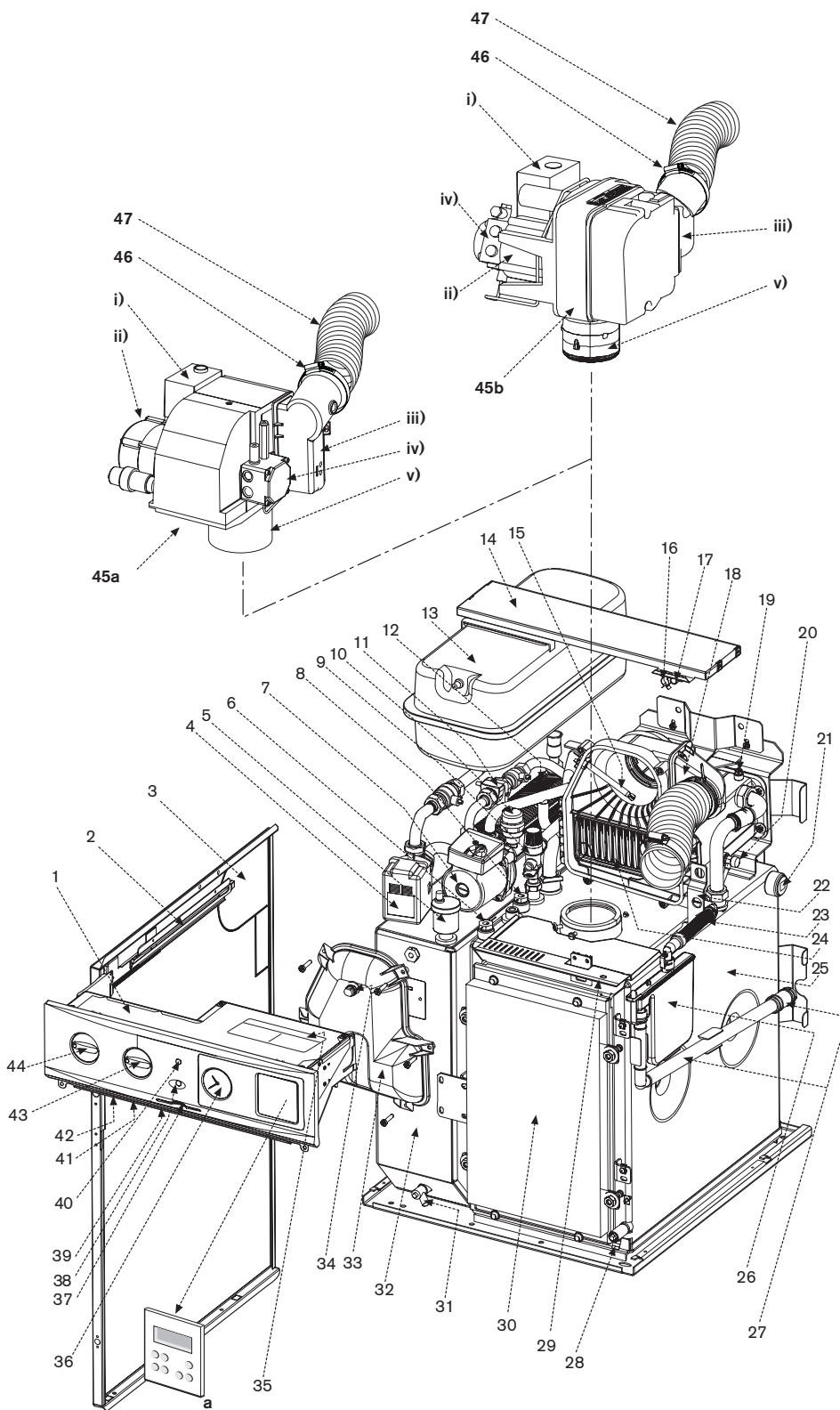

- 1 CONTROL BOX ASSEMBLY
- 2 CASING SIDE PANEL
- 3 FLUE 'KNOCK-OUT' SECTION
- 4 DIVERTER VALVE
- 5 AUTO AIR VENT
- 6 CH CONTROL & MANUAL RESET OVERHEAT THERMOSTATS
- 7 CIRCULATING PUMP
- 8 HIGH LIMIT THERMOSTAT (AUTOMATIC RESET)
- 9 PRESSURE RELIEF VALVE
- 10 PUMP AUTO AIR VENT (Under protective cap)
- 11 DHW FLOW SWITCH
- 12 DHW HEAT EXCHANGER
- 13 EXPANSION VESSEL
- 14 CASING SUPPORT PANEL
- 15 MANUAL RESET FLUE OVERHEAT THERMOSTAT
- 16 CLIP FOR FIRE VALVE SENSOR
- 17 CLIP FOR POWER CABLE
- 18 AIR INLET PIPE & CASING
- 19 SECONDARY HEAT EXCHANGER MANUAL AIR VENT
- 20 SECONDARY HEAT EXCHANGER DRAIN
- 21 COMBINED FEED & EXPANSION & OPEN SAFETY VENT PIPE OUTLET
- 22 OIL ISOLATION VALVE
- 23 FLEXIBLE CONDENSATE OUTLET PIPE
- 24 SECONDARY HEAT EXCHANGER
- 25 PRIMARY HEAT EXCHANGER
- 26 CONDENSATE TRAP
- 27 CONDENSATE DRAIN PIPE WITH PUSH FIT CONNECTOR
- 28 PRIMARY HEAT EXCHANGER DRAIN COCK
- 29 TRAY
- 30 COMBUSTION CHAMBER ACCESS DOOR
- 31 HEATSLAVE TANK DRAIN COCK
- 32 HEATSLAVE TANK
- 33 FLUE MANIFOLD ACCESS COVER
- 34 FLUE GAS SAMPLING POINT
- 35 DATA LABEL
- 36 PRESSURE GAUGE
- 37 QUICK REFERENCE GUIDE SLOT
- 38 LOCK-OUT INDICATOR
- 39 MANUAL RESET TANK OVERHEAT THERMOSTAT (behind plastic cover)
- 40 POWER ON INDICATOR
- 41 OVERHEAT RESET BUTTONS
- 42 LOCK-OUT RESET BUTTON
- 43 CH TEMPERATURE CONTROL
- 44 DHW TEMPERATURE CONTROL
- 45a BENTONESTERLINGBURNER(12/18&18/25)
 - i) Control box
 - ii) Motor
 - iii) Air intake casing
 - iv) Oil pump
 - v) Combustion head
- 45b RIELLO RDB 1 (12/18)
RIELLO RDB 2.2 (18/25, 25/32)
 - i) Control box
 - ii) Motor
 - iii) Air intake casing
 - iv) Oil pump
 - v) Combustion head
- 46 CLIP - AIR INTAKE HOSE
- 47 AIR INTAKE HOSE

OPTIONAL ACCESSORIES (not supplied)

- a - 7 day TWIN CHANNEL DIGITAL PROGRAMMER
Part No. 7 716 192 033 0

APPLIANCE INFORMATION

IMPORTANT: All the following Pre-Installation sections must be read and requirements met before starting boiler or flue installation.

CAUTION: ISOLATE THE MAINS SUPPLIES BEFORE STARTING ANY WORK AND OBSERVE ALL RELEVANT SAFETY PRECAUTIONS.

CLEANING PRIMARY SYSTEMS

IMPORTANT: Debris from the system can damage the boiler and reduce efficiency. Failure to comply with the guidelines for the use of water treatment with the appliance will invalidate the appliance warranty.

**BEFORE CLEANING THE SYSTEM:
ENSURE THE SYSTEM AND PIPEWORK IS IN GOOD WORKING ORDER.**

FLUSH THE EXISTING SYSTEM WITH A POWER FLUSHING MACHINE OR WITH A CHEMICAL CLEANER BEFORE INSTALLING NEW COMPONENTS.

CLEANING THE PRIMARY SYSTEM:

- ▶ Cleanse the system in accordance with BS 7593.
- ▶ Fill the system with cold mains water to the recommended pressure and check for leaks.
- ▶ Open all drain cocks and drain the system.
- ▶ Close drain cocks and add a suitable flushing agent at the correct strength for the system condition in accordance with the manufacturer's instructions.
- ▶ Circulate the flushing agent before the boiler is fired up.
- ▶ Run the boiler and system at normal operating temperature in accordance with the manufacturer's instructions.
- ▶ Drain and thoroughly flush the system to remove the flushing agent and any debris.



ELECTRIC SUPPLY:

- Supply: 230V - 50Hz.
- Cable: PVC insulated 0.75mm² (24 x 0.2mm) temperature rated to 90°C.
- Protection IP20.
- External 5A fuse to BS1362.
- The appliance must be earthed.
- Refer to IEE regulations for cross bonding requirements.
- It must be possible to isolate the appliance from the electrical supply with at least a 3mm contact separation in both poles supplying the appliance.
- Wiring between the appliance and the electrical supply must comply with IEE wiring regulations and any local regulations which may apply for fixed wiring to a stationary appliance.
- Any system connected to the boiler must not have a separate electrical supply.



WATER SUPPLY:

The following are general requirements and if necessary the advice of the local water company should be sought before fitting the appliance.

- The appliance cold water supply should be the first connection off the water main where possible.

Water Mains Pressure:

Minimum dynamic mains water pressure for maximum performance.

12/18kW	18/25kW	25/32kW
1.5 bar	1.2 bar	0.9 bar

- Maximum mains fed water pressure 10 bar. If necessary, fit a pressure reducing valve.

IMPORTANT: Non-return, back flow prevention devices (including those associated with water meters) fitted to the mains water supply can cause a pressure build up which could damage the boiler and other household appliances.

- Where the water main supply has a non-return, back flow prevention valve fitted, a mini expansion vessel (A) must be connected to the mains water inlet pipe (B) between the non-return valve (C) and the boiler (D) as shown opposite.

Use in hard water areas:

Normally there is no need for water treatment to prevent scale formation as the maximum temperature of the heat exchanger is limited by the electronic control circuit.

In areas where the temporary water hardness exceeds 200ppm, consideration may need to be given to the fitting of a scale prevention device. In such circumstances, the advice of the local water authority should be sought.

MAINS WATER EXPANSION VESSEL:

- A - Mini expansion vessel, part No. 7 716 192 105
- B - Mains water inlet
- C - Non-return valve
- D - Boiler

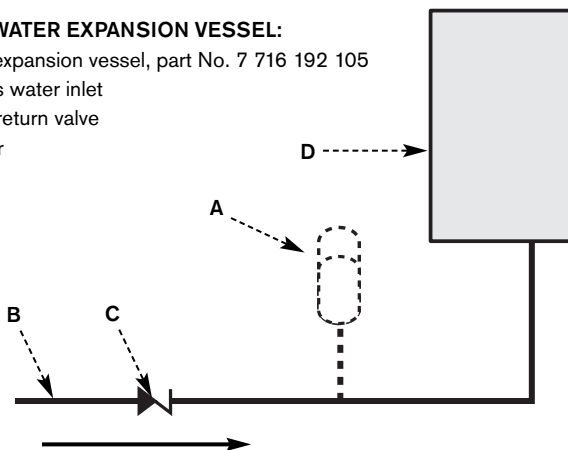

- A - Oil storage tank.
- B - Isolating valve.
- C - Oil strainer & water separator.
- D - Fire valve to BS 5410.
- E - External wall.
- F - Fire valve sensor.
- G - Oil burner.
- H - Oil supply pipe.
- J - Oil pump.
- K - Full base (plastic tanks).
- L - Non-return valve.
- M - De-aerator.
- N - Oil filter (16µm max filtration size)

NOTE: All dimensions are in metres unless stated otherwise.

The maximum pipe run figures are based on using copper pipe with an inside diameter of 2mm less than the Ø.

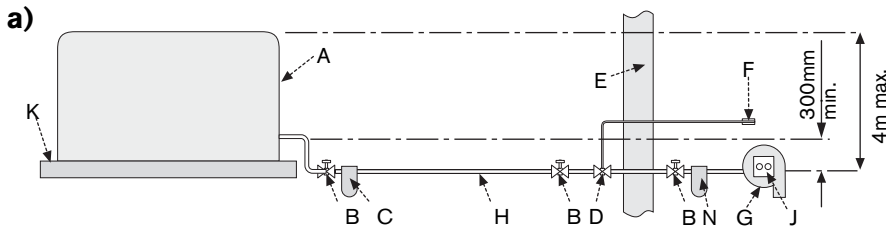

MAXIMUM PIPE RUN FOR SINGLE PIPE GRAVITY FEED SYSTEM

HEAD	10mmØ	12mmØ	HEAD	10mmØ	12mmØ
0.5	12	30	2.5	62	100
1.0	25	69	3.0	74	100
1.5	37	91	3.5	87	100
2.0	49	100	4.0	99	100

a) Single pipe gravity feed system:

The oil storage tank (A) must be positioned so that the oil level does not exceed 4 metres above the level of the burner oil pump (J) and in addition the oil level must be at least 300mm above the oil pump (J). Where the maximum oil level in the oil storage tank exceeds 4 metres, a head breaking device must be installed between the tank (A) and the burner oil pump (J).

b) Double pipe sub-gravity feed system:

Maximum suction height 3.5 metres. Non-return valves must be fitted to the inlet and return oil line between the oil pump (J) and oil storage tank (A).

c) Single pipe suction lift with de-aerator

Maximum suction height 3.5 metres. The oil tank (A) must be positioned below the oil pump (J). Create an inlet and return loop between the de-aerator (M) and oil pump (J).

A non-return valve must be incorporated within the de-aerator or fitted to the oil line between the oil storage tank (A) and the de-aerator (M).

A top feed oil tank fitted with a de-aerator using an internal non-return valve should have any non-return valves fitted in the base of the tank to the suction line removed to assist purging air from the oil line.

Pipework

- ▶ Use copper pipe of the correct diameter according to the information shown opposite. Use flexible hoses to connect to the oil pump (J).
- ▶ Lay the oil supply pipe (H) as straight and level as possible to avoid air pockets and unnecessary friction losses. Route away from the boiler access door or other hot surfaces.
- ▶ Install a manual isolating valve (B) to the oil supply pipe (H), as close to the oil storage tank (A) as possible.
- ▶ Fit an oil strainer and water separator (C) to the oil supply pipe, near the oil storage tank. Fit an additional oil filter (N, 16µm max filtration size) close to the boiler, but not inside the boiler casing.
- ▶ Fit a fire valve in accordance with BS 5410. The fire valve (D) should be fitted externally to the building with the fire valve sensor (F) located within the appliance case.

A fire valve with a shut off temperature of 85°C or higher must be fitted to avoid the possibility of nuisance shut offs.

A capillary type valve provides a neat and simple installation. Alternatively, a fusible link or electrical system may be used.

Under no circumstances should a combination isolating/fire valve be used as the sole fire protection device.

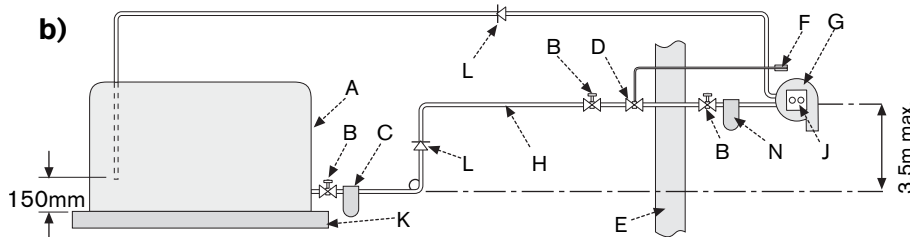

MAXIMUM PIPE RUN FOR DOUBLE PIPE SUB-GRAVITY FEED SYSTEM

HEAD	10mmØ	12mmØ	HEAD	10mmØ	12mmØ
0	50	100	2.0	26	66
0.5	44	100	2.5	20	50
1.0	38	95	3.0	14	37
1.5	32	80	3.5	8	22

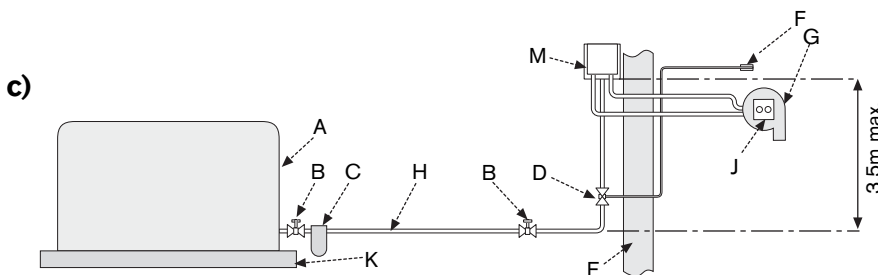

MAXIMUM PIPE RUN FOR SINGLE PIPE SUCTION LIFT WITH DE-AERATOR

HEAD	FUEL FLOW RATE				HEAD	FUEL FLOW RATE			
	2.5kg/h 8mmØ	5kg/h 8mmØ	10kg/h 8mmØ	10kg/h 10mmØ		2.5kg/h 8mmØ	5kg/h 8mmØ	10kg/h 8mmØ	10kg/h 10mmØ
0	100	55	26	100	2.0	60	30	14	65
0.5	95	45	23	100	2.5	45	25	11	50
1.0	80	40	20	90	3.0	35	15	8	35
1.5	70	35	17	75	3.5	25	10	5	20

The table and illustration above is a guide only and does not in any way override the de-aerator manufacturers instructions.

IMPORTANT: The boiler should not be allowed to operate with a return temperature of less than 40°C when the system is up to operating temperature.

PRIMARY SYSTEM PLASTIC PIPEWORK:

- Any plastic pipework used for the CH system must have a polymeric barrier, complying with BS 7921 and installed to BS 5955 with 1000mm (minimum) length of copper or steel pipe connected to the boiler.
- Plastic pipework used for underfloor heating must be correctly controlled with a thermostatic blending valve limiting the temperature of the circuits to approx. 50°C with 1000mm (minimum) length of copper or steel pipe connected to the boiler.

PRIMARY SYSTEM/CONNECTIONS/VALVES:

- Do not use galvanised pipes or radiators.
- All system connections, taps and mixing valves must be capable of sustaining a pressure of 3 bar.
- Radiator valves should conform to BS 2767:10.
- All other valves should conform to BS 1010.
- On new installations TRVs must be used on all radiators except the radiator where the room thermostat is sited, this must be fitted with lockshield valves and left open. All installations should have TRVs fitted to radiators within the sleeping accommodation.
- An automatic bypass valve must be connected between the heating flow and return pipes where TRVs are used on radiators. This must be fitted to give at least a 3m circuit when activated.
- Drain cocks are required at all the lowest points on the system.
- Air vents are required at all high points on the system.

PRE-INSTALLATION

TYPICAL OPEN VENT SYSTEM

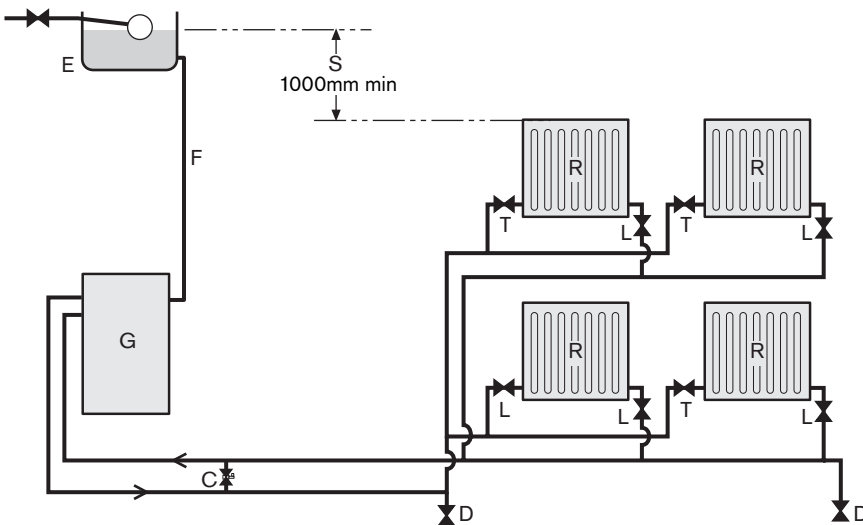

- | | | |
|--------------------------------|--|-----------------------|
| A - Appliance expansion vessel | F - Combined feed & expansion and open vent safety pipe. | R - Radiators |
| B - Extra expansion vessel | G - Appliance | S - Static head |
| C - Automatic bypass valve | L - Lockshield valve | T - TRV |
| D - Drain cock | P - Pressure relief discharge | U - To filling system |
| E - Feed & expansion cistern | | |

TYPICAL SEALED SYSTEM

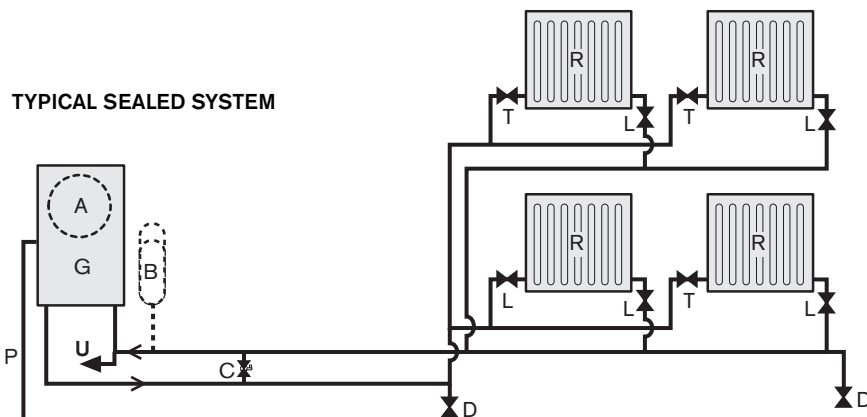

OPEN VENT PRIMARY SYSTEM:

- In order to comply with BS 5449 the combined feed and vent pipe must be connected to the BSP outlet on the right hand side of the primary heat exchanger.
- The feed and expansion cistern (E) must be positioned to provide a static head (S) of at least 1 metre above the highest point in the heating system to the water level in the feed and expansion cistern (E).
- No valve shall be fitted in the combined feed and expansion and open vent pipe (F).
- The combined feed and expansion and open vent pipe (F) must be at least 22mmØ.

SEALED PRIMARY SYSTEM:

- Where the system volume is more than 180 litres at 0.5 bar or exceeds 2.65 bar at maximum heating temperature an extra expansion vessel (B) must be fitted as close as possible to the appliance in the central heating return.
- Pressurise the extra expansion vessel (B) to the same figure as the expansion vessel (A) built into the appliance.

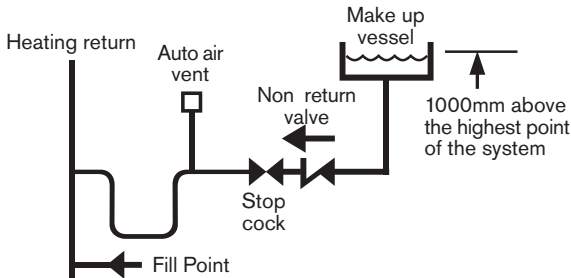
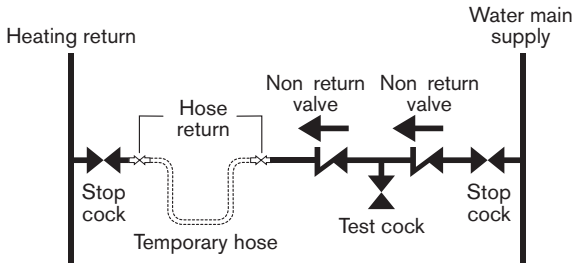

PRE -
INSTALLATION

- J - Outside wall.
- K - Drain pipe.
- L - External drain.

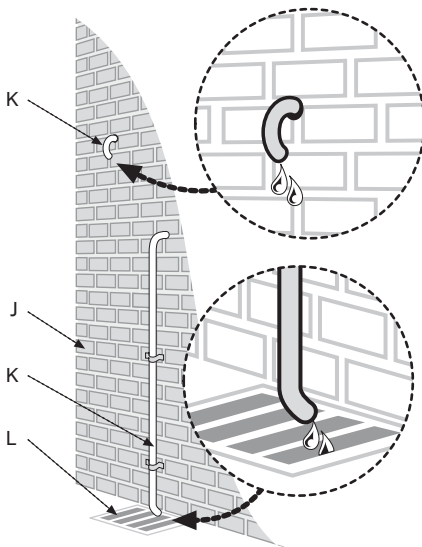

FILLING PRIMARY SEALED SYSTEMS:

- Filling the system must comply with one of the methods shown opposite.
- The filling point must be at low level and must never be a permanent direct fixing to the mains water supply.
- Filling links must be WRAS approved.

SHOWERS/BIDETS:

- If a shower head can be immersed in water or comes closer than 25mm from the top edge of a bath or shower tray spill over level then an anti-siphon device must be fitted to the shower hose.
Only thermostatically controlled showers are suitable for use with this appliance.
- Bidets with direct hot & cold mains water can be used (with the approval of the local water authority) and must be the over rim flushing type with shrouded outlets to prevent the fitting of hand held sprays.

DOMESTIC HOT WATER:

- **Plastic pipework must not be used for the DHW system.**
- Taps and mixing valves must be capable of sustaining a pressure up to 10 bar in accordance with the Water Regulations as they will be operating at mains water pressure.
- Hot water temperature and flow rate are affected by the size and insulation of pipework making up the distribution system and are controlled by the hot water tap and the water main inlet pressure. A mixing valve can be fitted if a more permanent setting is required.
- If using more than one outlet at once causes water flow starvation, fit flow balancing valves or Ball-O-Fix valves to the appropriate outlets.

PRESSURE RELIEF PIPEWORK:

- The pressure relief drain pipe (K) should be at least 15mm diameter copper pipe and run downwards away from the boiler and discharge away from any electrics or other hazard, preferably to an external drain or soakaway.
- Pipe (K) should be finished with a partial bend, near the outlet to face the external wall (as shown) to help prevent freezing.

IMPORTANT: The pressure relief valve is a safety device for the boiler and if activated may discharge boiling water or steam through the relief valve drain pipe. Care should be taken when siting the outlet pipe so that it does not cause an obstruction or discharge above a window, entrance or other public access where it could cause a hazard.

CONDENSATE & PRESSURE RELIEF PIPEWORK

CONDENSATE PIPEWORK:

- All national and, where appropriate, local regulations for the discharge and neutralisation of condensate should be followed.
- The condensate pipe must be a minimum of 21.5mmØ polypropylene pipe.
- The condensate pipework must fall at least 50mm per metre towards the outlet and should take the shortest practicable route.
- Support the pipe at least every 0.5m for near horizontal runs and 1m for vertical runs.
- When a boiler is to be installed in an unheated location, such as a garage, all condensate pipes should be considered as external.

External pipework:

- The 21.5mmØ pipe must not exceed 3 metres outside the building. If a run greater than 3m is required, 32mmØ pipe must be used.
- Any pipe exposed to windchill or extreme cold must be 32mmØ.
- Protect all external pipes with weather resistant insulation and box-in, if necessary to reduce the risk of freezing.
- Terminate as close to the ground or drain as possible (below the grating and above the water level) while still allowing for safe dispersal of the condensate. This will help reduce windchill freezing.

Connection of a condensate pipe to a drain may be subject to local building regulations.

Making it safe:

- Condensate pipework must not leak, freeze or block up.
- Condensate traps must be filled before starting up the boiler to prevent potentially harmful flue products escaping via the condensate route.
- Do not dispose of condensate into water recovery systems.

Condensate can be discharged into a rain water hopper which is part of a sewer system carrying both rain water and foul water.

- The pipework must follow one of the options shown opposite:

a - Internal waste drainage system

b - Soil/vent stack

c - External drainage system

d - External condensate absorption point

- A - Condensate from the boiler internal condensate trap which has a 75mm water seal.
- B - Sink.
- C - 21.5mm Ø polypropylene condensate pipe.
- D - Gully.
- E - Internal soil and vent stack.
- F - 300mm x 100mm Ø sealed plastic tube.
- G - Ground level.
- H - Drainage holes 50mm from base of tube (12mm Ø at 25mm centres) facing away from building.
- I - Limestone chippings.

PRESSURE RELIEF PIPEWORK:

- The pressure relief drain pipe (K) should be at least 15mm diameter copper pipe and run downwards away from the boiler and discharge away from any electrics or other hazard, preferably to an external drain or soak away.
- Pipe (K) should be finished with a partial bend, near the outlet to face the external wall (as shown) to help prevent freezing.

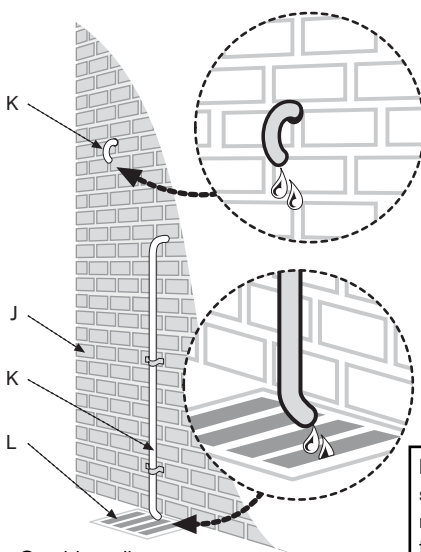
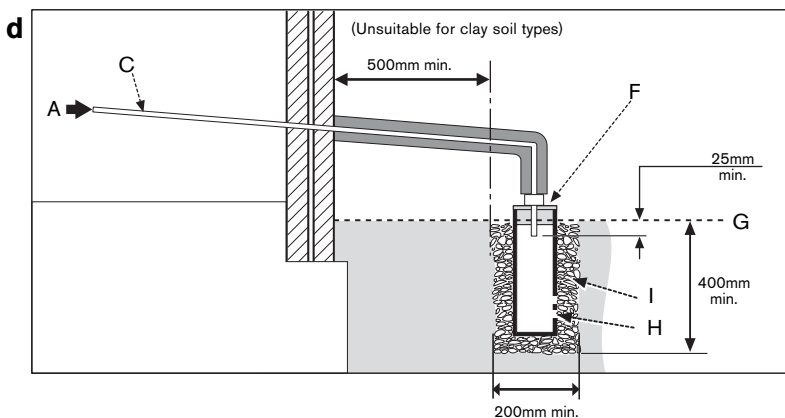
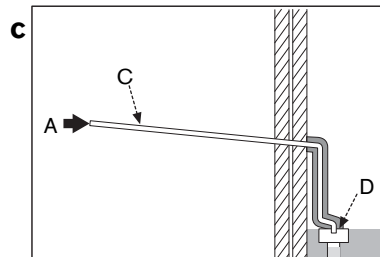
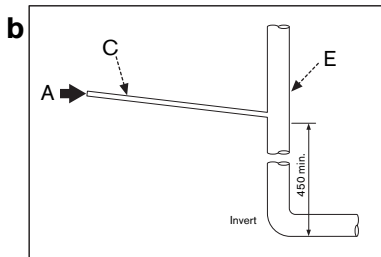
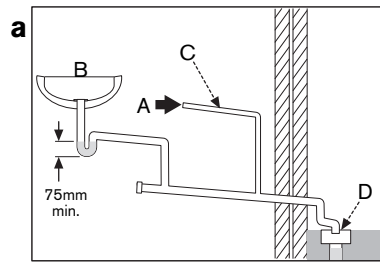

- J - Outside wall.
- K - Drain pipe.
- L - External drain.

IMPORTANT: The pressure relief valve is a safety device for the boiler and if activated may discharge boiling water or steam through the relief valve drain pipe. Care should be taken when siting the outlet pipe so that it does not cause an obstruction or discharge above a window, entrance or other public access where it could cause a hazard.

PRE-INSTALLATION

**a: RECOMMENDED
INSTALLATION CLEARANCES**

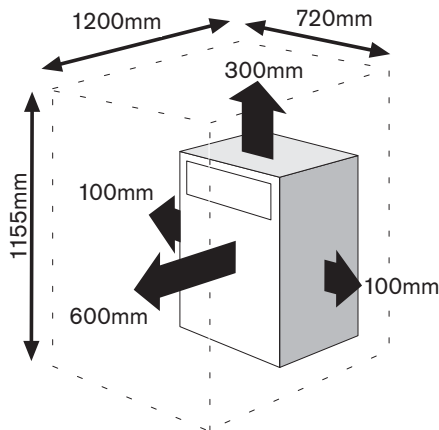

b: ANNUAL SERVICE CLEARANCES

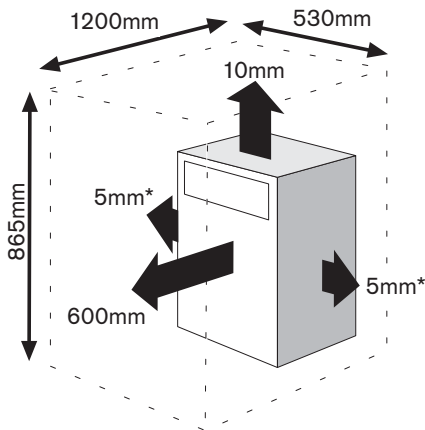

c: MAINTENANCE & REPAIR CLEARANCES

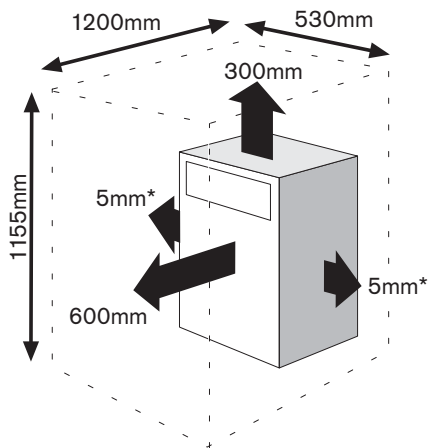

MINIMUM AIR VENT AREA (cm²) FOR APPLIANCES INSTALLED IN A COMPARTMENT:

¹ Internal air to and from a space/room inside the building. ² External air to and from directly outside the building.

Conventional flue					Room Sealed flue:				
kW	Internal ¹ ventilation		External ² ventilation		kW	Internal ¹ ventilation		External ² ventilation	
	High Level	Low Level	High Level	Low Level		High Level	Low Level	High Level	Low Level
12/18	198	279	99	198	12/18	198	198	99	99
18/25	275	413	138	275	18/25	275	275	138	138
25/32	352	528	176	352	25/32	352	352	176	176

BOILER LOCATION &

CLEARANCES

- This boiler is only suitable for installing internally within a property at a suitable location onto a fixed rigid surface of the same size as the boiler and capable of supporting the boiler weight.
- The boiler must be installed on a flat level surface to ensure condensate does not enter the primary heat exchanger.
- The boiler is not suitable for external installation unless a suitable enclosure is provided.
- Roof space installations must fully conform to BS 5410 part 1 section 4.6.9.

Open flue model (CF):

- In order to ensure clean and efficient combustion an adequate supply of air must be delivered to the combustion chamber.
- To provide sufficient air a suitable inlet must be provided into the room or space in which the boiler is situated.

CF minimum air inlet sizes**

Output	12/18kW	18/25kW	25/32kW
Size cm ²	99	138	176

An air brick or other form of continuous air supply may have to be built into the installation in order to ensure an adequate supply of air.

- If the appliance is to be installed in a confined space or compartment two air vents are required, one at high level and one at low level.

The minimum free area of each vent is shown opposite and depends whether the air is taken from another room or from outside the building.

- Where the air is taken from another room that room must contain an air inlet as described above.

Room sealed balanced flue model (RS):

The appliance does not require a separate vent for combustion air.

- Installation in cupboards or compartments require permanent vents for cooling purposes, one at high level and one at low level, either direct to outside air or to a room.
- Both vents must pass to the same room or be on the same wall to the outside air.

The minimum air vent free area is given in the table opposite.

a: INSTALLATION CLEARANCES:

Diagram (a) shows the minimum space recommended to install the boiler only.

b: SERVICE CLEARANCES:

Diagram (b) shows the minimum space required to carry out an annual service.

c: MAINTENANCE & REPAIR CLEARANCES:

The appliance is suitable for an under worktop installation providing that the worktop above the boiler (min 10mm clearance) is removable for maintenance and repair and the front of the boiler is not enclosed.

* Remove the flue 'knock-out' panel sections if this clearance is less than 75mm.

** Due to changes to BS 5410 and modern building design, these figures no longer incorporate the adventitious ventilation allowance.

COMPARTMENTS:

Follow the requirements of BS 5410 and note:

- Minimum clearances must be maintained.
- An access door is required to install, service and maintain the boiler and any ancillary equipment.
- If fitting the boiler into an airing cupboard use a non-combustible material (if perforated, maximum hole sizes of 13mm) to separate the boiler from the airing space.

Venting compartments:

There must be sufficient clearance around the appliance to allow proper circulation of ventilation air. The clearances required for installation and servicing will normally be adequate for ventilation.

- Ventilation must be provided for boilers fitted into compartments as described in BS 5410.
- Combustion air must not be taken from a room or internal space containing a bath or shower and must not communicate with a protected area such as a hall, stairway, landing, corridor, lobby, shaft etc.
- Air vents must allow access for clean free air and must be sited to comply with the flue terminal position requirements.
- Air ducting runs must not exceed 3m.
- Low level air vents must be less than 450mm from the floor.
- A warning label must be added to the vents with a statement to the effect: "Do not block this vent. Do not use for storage."

SHOWER / BATHROOMS:

The boiler **must not** be installed in zones 0, 1 or 2 (the shaded areas shown on the diagrams opposite).

IMPORTANT: conventional flued boilers must not be fitted in a bathroom.

IMPORTANT: any appliance control using mains electricity must not be able to be touched by a person using the bath or shower. Electrical switches, fused spur and socket outlets must not be fitted in the bathroom. In all cases the IEE wiring regulations must be consulted. All pipework in bathrooms and shower rooms must be cross bonded.

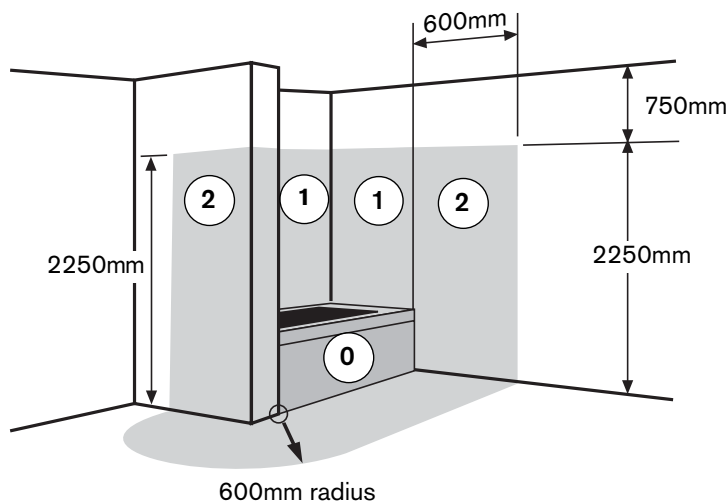
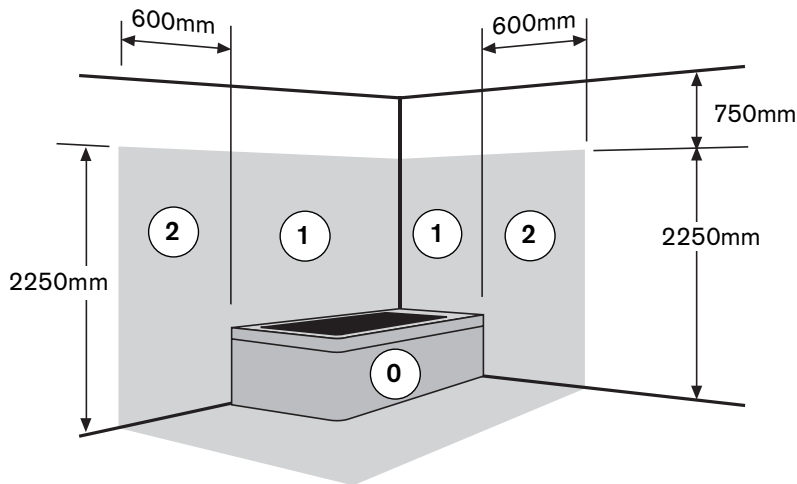

Minimum dimension of the flue terminal position for oil fired appliances:

TERMINAL POSITION		CF	RS(H)	RS(V)
A ^{1,4}	Directly below an opening, air brick, opening window, etc	N/A	600mm	N/A
B ^{1,4}	Horizontally to an opening, air brick, opening window, etc	N/A	600mm	N/A
C ⁸	Below a plastic/painted gutter, drainage pipe or eaves if combustible material protected	N/A	75mm	N/A
D ⁸	Below a plastic/painted gutter, drainage pipe or eaves without protection to combustible material	N/A	600mm	N/A
E	From vertical sanitary pipework	N/A	300mm	N/A
F ³	From an external or internal corner or from a surface or boundary alongside the terminal	N/A	300mm	N/A
G ⁵	Above ground or balcony level	N/A	300mm*	N/A
H ³	From a surface or boundary facing the terminal	N/A	600mm**	N/A
J	From a terminal facing the terminal	—	1200*mm	—
K	Vertically from a terminal on the same wall	N/A	1500mm	N/A
L	Horizontally from a terminal on the same wall	—	750mm	—
M	Above the point of highest intersection with the roof	600mm	—	600mm
N ²	From a vertical structure on the side of the terminal	750mm	—	750mm
O ²	Above a vertical structure less than 750mm from the side of the terminal	600mm	—	600mm
P ²	From a ridge terminal to a vertical structure on the roof	1500mm	—	N/A
Q	Above or to the side of any opening on a flat or sloping roof	300mm	—	300mm
R	Below any opening on a sloping roof	1000mm	—	1000mm

Key: — Not applicable, N/A Not allowed, CF Conventional flue, RS(H) Room Sealed Horizontal flue, RS(V) Room Sealed Vertical flue.

Notes:

1. Terminals should be positioned so as to avoid products of combustion accumulating in stagnant pockets around the building or entering into buildings.
2. Vertical structure in N, O and P includes tank or lift rooms, parapets, dormers etc.
3. Terminating positions should be at least 1.8m from an oil storage tank unless a wall with at least 30 min fire resistance and extending 300mm higher and wider than the tank is provided between the tank and the terminating position.
4. Where a flue is terminated less than 600mm away from a projection above it and the projection consists of plastics or has a combustible or painted surface, then a heat shield of at least 750mm wide should be fitted.
5. If the lowest part of the terminal is less than 2m above the ground, balcony, flat roof or other place to which any person has access, the terminal should be protected by a guard.
6. Notwithstanding the dimensions given above, a terminal should not be sited closer than 300mm to combustible material. In the case of a thatched roof, double this separation distance should be provided. It is also advisable to treat the thatch with a fire retardant material and close wire in the vicinity of the flue.
7. It is essential that a flue or chimney does not pass through the roof within the shaded area delineated by dimensions Q and R.
8. Where protection is provided for plastic components, such as guttering, it is essential that this is to the standard specified by the manufacturer of the plastic components.

FLUE TERMINAL POSITIONS

- Flue terminals must be positioned to avoid combustion products entering into buildings.
- The flue must be fitted and terminated in accordance with the recommendations of BS 5410.
- The flue must not cause an obstruction.
- Discharge from the flue outlet must not be a nuisance.
- Flue gases have a tendency to plume and in certain weather conditions a white plume of condensation will be discharged from the flue outlet which could be regarded as a nuisance, for example, near security lighting.
- There should be no restriction preventing the clearance of combustion products from the terminal.
- The air inlet/outlet duct and the terminal of the boiler must not be closer than 25mm to any combustible material. Detailed recommendations on protection of combustible materials are given in BS 5410:1
- A protective terminal guard must be fitted if the terminal is 2m or less above a surface where people have access. The guard must be spaced equally (minimum 50mm) around the flue and fixed to the wall with plated screws.

Stainless steel terminal guard.
Part No: 7 716 190 050

The following additional guidelines (from part L Exceptions Guidance Document) are recommended when determining the flue outlet position:

- Avoid discharging flue gases into car ports or narrow passageways.
- *Minimum distance of the flue terminal from above ground is 2100mm where directed to a public footpath, private access route or a frequently used area and 2500mm from a car parking area.
- **Minimum distance of the flue terminal to a facing wall, fence, building or property boundary is 2500mm.

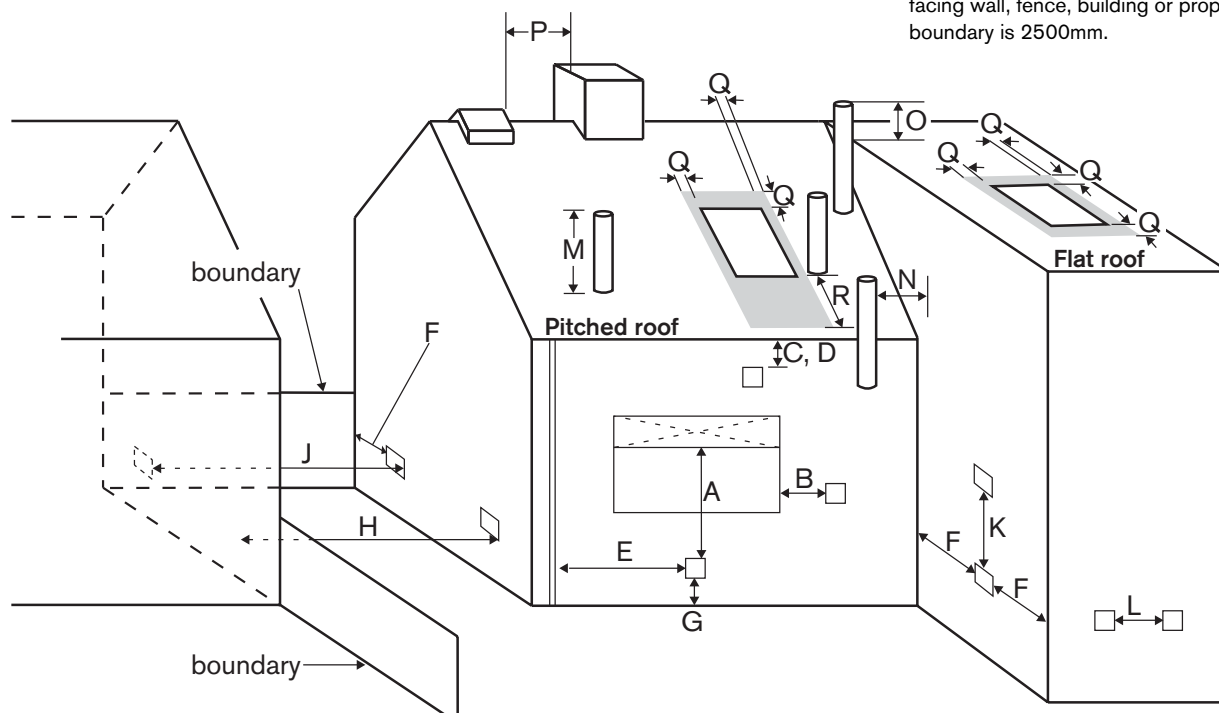

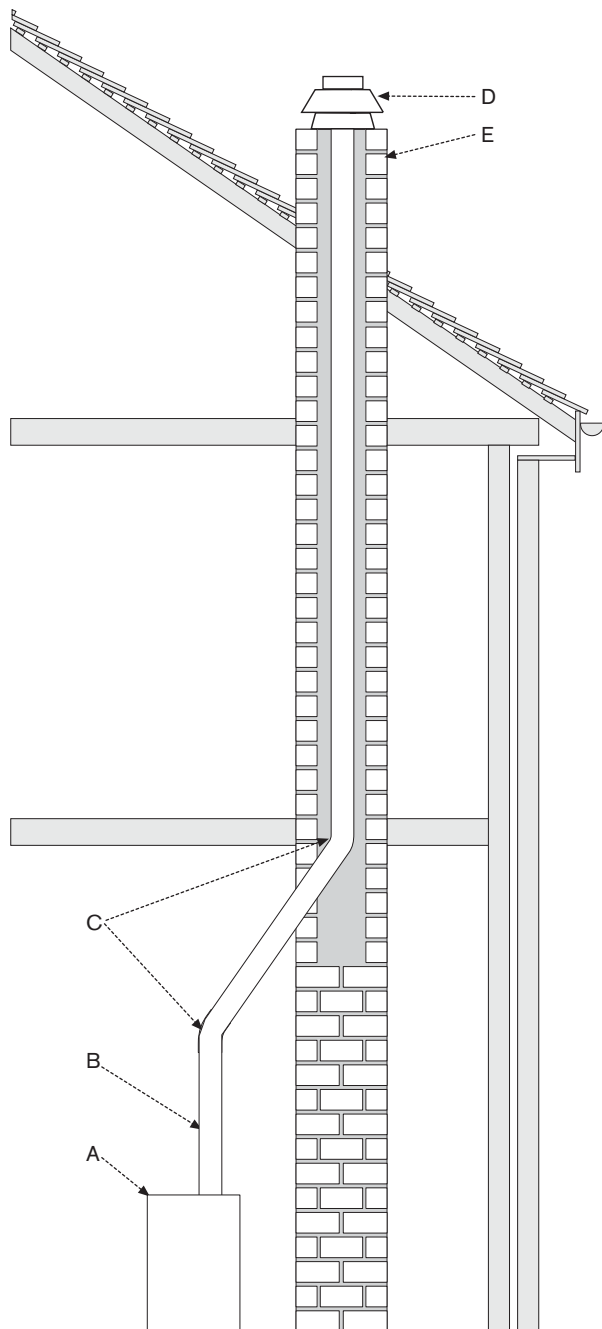

- A - Boiler
- B - Flue
- C - Max. 2 bends at 135°
- D - Anti down-draught terminal
- E - Chimney

- Open (conventional) flued appliances must not be installed in a bedroom, bathroom or bedsitting room.
- The flue system must be in accordance with BS 5410 : Part 1 and the current Building Regulations.
- The flue must be constructed of materials suitable for use with condensing combustion products.
- External flue systems must be of the insulated type.
- Brick and masonry chimneys must be lined with a suitable non-combustible material and properly jointed to withstand the effects of the working temperature (minimum rating of material 120°C) of the appliance and any condensate which may form.
- All flue joints must be sealed to prevent the leakage of condensate and combustion products.
- Ensure that joints are made so that the condensate runs away and is not collected within the joint.

NOTE: The flue can be increased in size from the boiler take off point providing the joint is correctly sealed. Never reduce the flue diameter from the boiler take off point.

CF Sizing:

- 12/18 and 18/25 = 100/103mmØ
- 25/32 = 130mmØ*

***Unless installing Worcester Greenstar Oilfit Conventional 100mmØ Flexible flue.**

- Because the flue operates at a lower temperature on a condensing boiler compared to that of a conventional appliance, the flue draught will be lower. Typically the draught will be between 0.5mmwg and 4.4mmwg, measured with the flue warm but the burner not firing. The actual figure will vary depending on weather conditions, flue height and position.
- The flue should be vertical and contain as few bends as possible, a maximum of two 135° bends should be used.
- The flue outlet must be extended beyond the eaves of the building and where possible, above the apex.
- Fit a suitable anti down-draught terminal where down draughts are experienced.

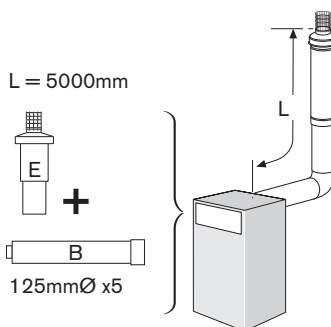
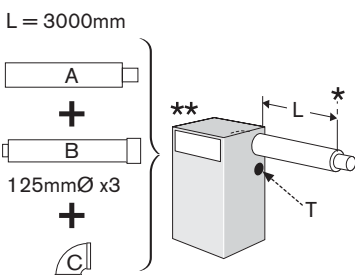
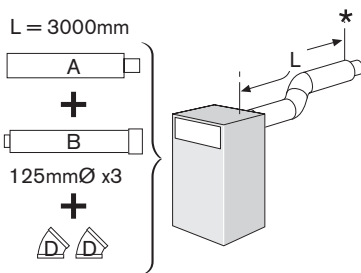
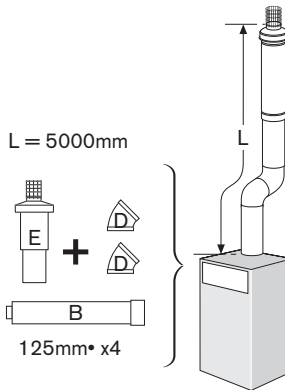
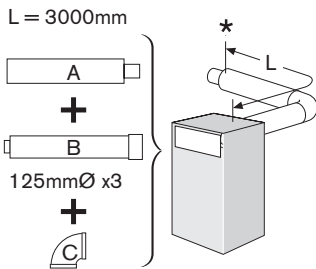
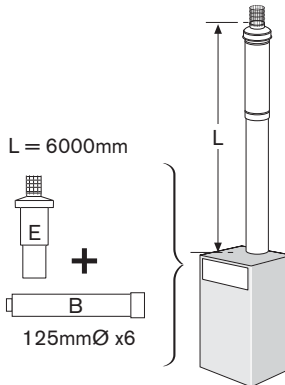
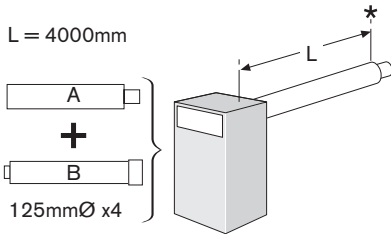
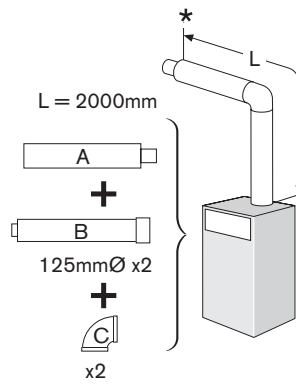
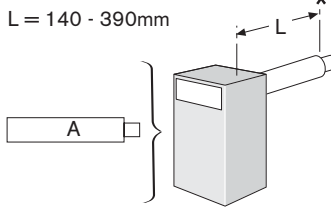

ROOM SEALED FLUE OPTIONS

The diagrams (opposite) show the components used and the maximum flue length (L) for each flue configuration.

In all cases L is measured from the outside of the boiler casing.

- To achieve the maximum flue length (L), a flue section will have to be reduced in length.
- Only the flue terminal or straight flue extensions can be reduced in length by cutting.
- The flue terminal end can be fitted from the inside or outside of the building.

IMPORTANT: All horizontal sections must rise away from the boiler by 52mm per metre (3°) to allow the condensate to drain back to the boiler.

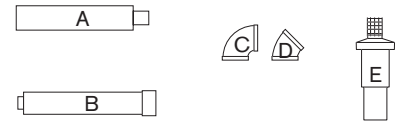

- A - Horizontal terminal
- B - Straight flue extension
- C - Flue bend 90°
- D - Flue bend 45°
- E - Vertical Terminal Kit (incl. 90° elbow)

Calculating the flue length:

Measure the total flue length required, noting that the maximum straight flue length including the terminal is:

Horizontal 80/125mmØ: 4000mm (excluding 120mm of terminal extending outside the building)

Vertical 80/125mmØ: 6000mm (measured from the boiler top panel).

Then reduce the total straight flue length for each extra flue bend (excluding the vertical flue kit 90° elbow) by:

1000mm for 90°

500mm for 45°

Flue Extension lengths:

Horizontal & Vertical 80/125mmØ: 1000mm overall length.

Effective length when engaged into sockets within the flue run is 950mm.

Flue Terminal lengths:

Horizontal 80/125mmØ: 350-460/470-670mm

Vertical 80/125mmØ: 1080mm + cage

* to outside wall.

** to use the left hand boiler flue outlet the expansion vessel must be removed and the connection from the boiler capped off. The expansion vessel must be fitted outside the boiler and connected to the boiler right hand side 1" BSP tapping (T).

IMPORTANT: All the previous Pre-Installation sections must be read and requirements met before starting boiler or flue installation.

UNPACKING THE BOILER

LIFTING AND CARRYING PRECAUTIONS:

- Lift only a manageable weight, or ask for help.
- When lifting or putting things down, bend the knees, and keep the back straight and feet apart.
- Do not lift and twist at the same time.
- Lift and carry objects close to the body.
- Wear protective clothing and gloves to protect from any sharp edges.

Unpacking:

It is advised that two or more persons are involved in the transfer of the packaged boiler from the van to the point of delivery.

- ▶ Once the packaged boiler has been delivered, the outer carton is removed first. Care should be taken when releasing the straps. If a sharp implement is used make sure the outer carton is not pierced and that the implement is used in such a way so that it may not cause personal injury. All sharp objects must be covered or the blade retracted after use and put away in a safe place.
- ▶ Lift carton up and away from the boiler.
 - ▶ Remove the plastic bag and upper front protection cover from the boiler and place safely aside.
- ▶ Pull base of front panel (E) away from the boiler to disengage ball stud connectors.
 - ▶ Lift front panel (E) upwards off the top supporting ledge and store safely away from the working area.
- ▶ Remove the bolts securing the boiler to the transport pallet.
 - ▶ Two or more persons are required to remove the boiler from the pallet taking care not to damage the boiler, panels or the floor.

At all times the correct method for handling heavy objects should be strictly observed.

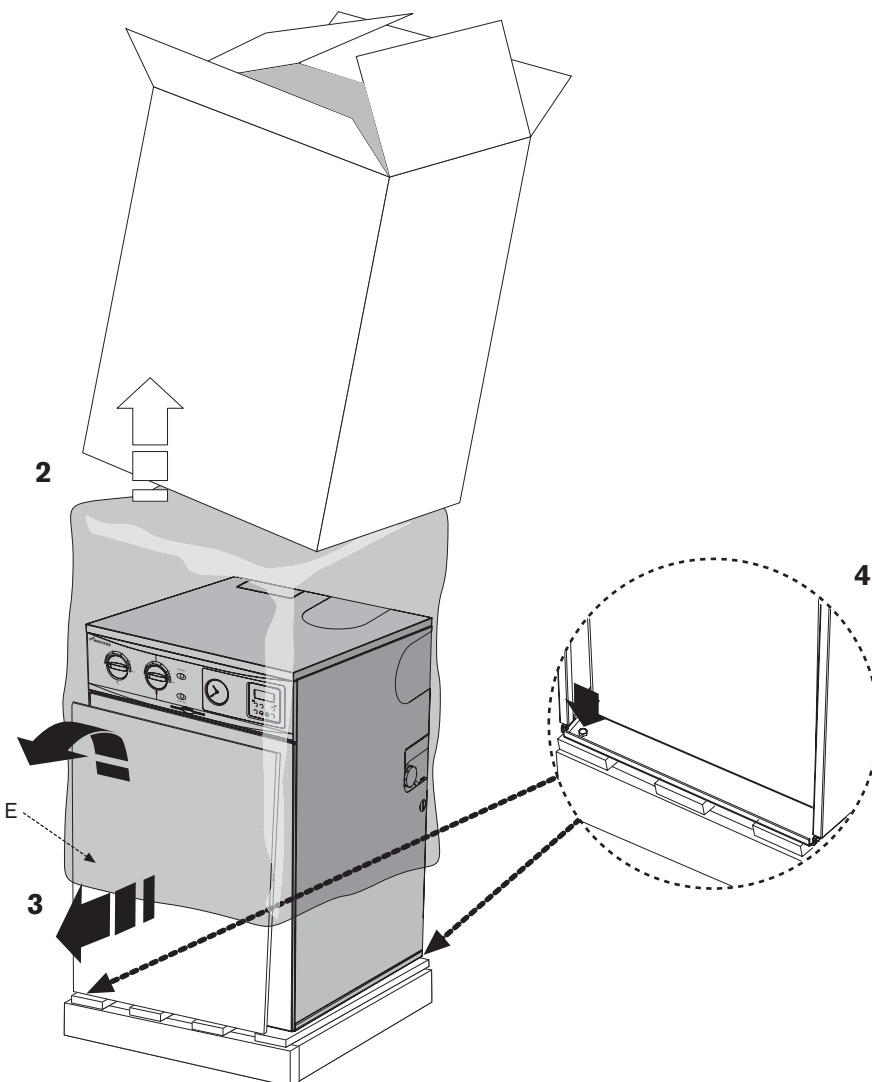
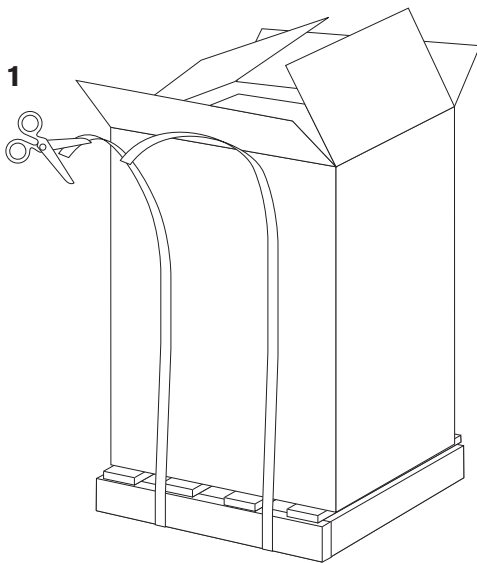

FLUE OPENING

CAUTION: Ensure there are no pipes, electric cables, damp proof courses or other hazards before drilling.

SAFETY:

All relevant safety precautions must be undertaken. Protective clothing, footwear, gloves and safety goggles must be worn as appropriate.

PIPEWORK POSITIONS:

A to H (opposite) show the flue and pipe positions:

- A - CH flow 22mmØ copper (28mmØ on 25/32kW model)
- B - DHW flow 22mmØ copper
- C - DCW mains water inlet 15mmØ
- D - CH return 22mmØ copper (28mmØ on 25/32kW model)
- E - Optional combined feed and expansion and open vent pipe 1" BSP
- F - Flue outlet
- G - Pressure relief pipe 15mmØ
- J - Condensate outlet 21.5mmØ

NOTE: For servicing purposes, keep the condensate and pressure relief discharge pipes away from components and pipework connections.

FLUE OPENING:

- ▶ Follow the diagram opposite to mark the centre of the flue (1, & 2) for rear opening, (2 & 3) for side opening or (1 & 4) for top opening.

**** IMPORTANT:** for horizontal flues, increase this height by 52mm for every 1000mm of horizontal length that the flue opening is away from the boiler.

NOTE: All horizontal flue sections must rise away from the boiler by 52mm per metre to ensure that condensate flows back into the boiler for safe discharge via the condensate waste pipe.

- ▶ Make an opening (X, Y or Z) through the wall using a core drill or similar at a size relative to the wall thickness as shown below:

125mmØ flue:	
Wall thickness	Flue hole size
150 - 240mm	155mmØ
240 - 330mm	160mmØ
330 - 420mm	165mmØ
420 - 500mm	170mmØ

INSTALLATION

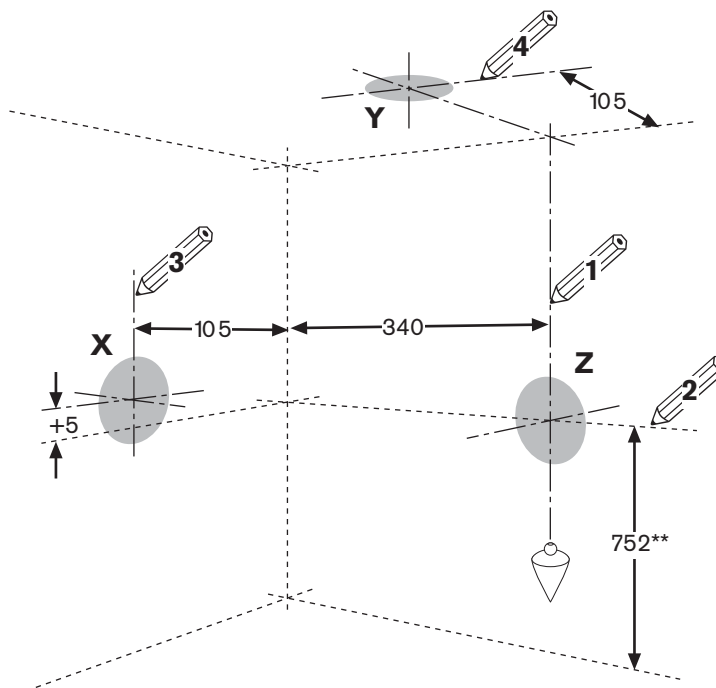
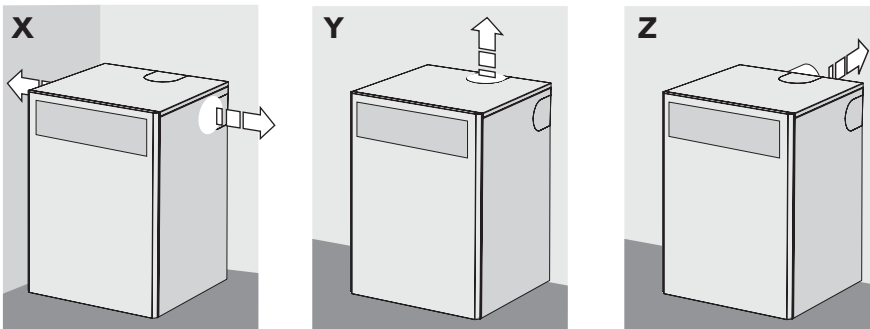
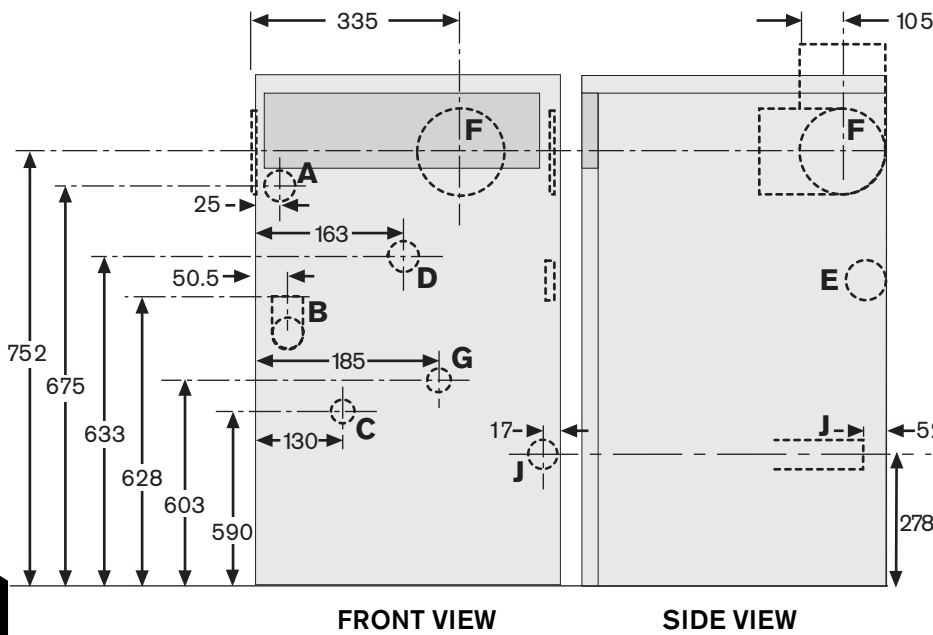

BOILER INSTALLATION

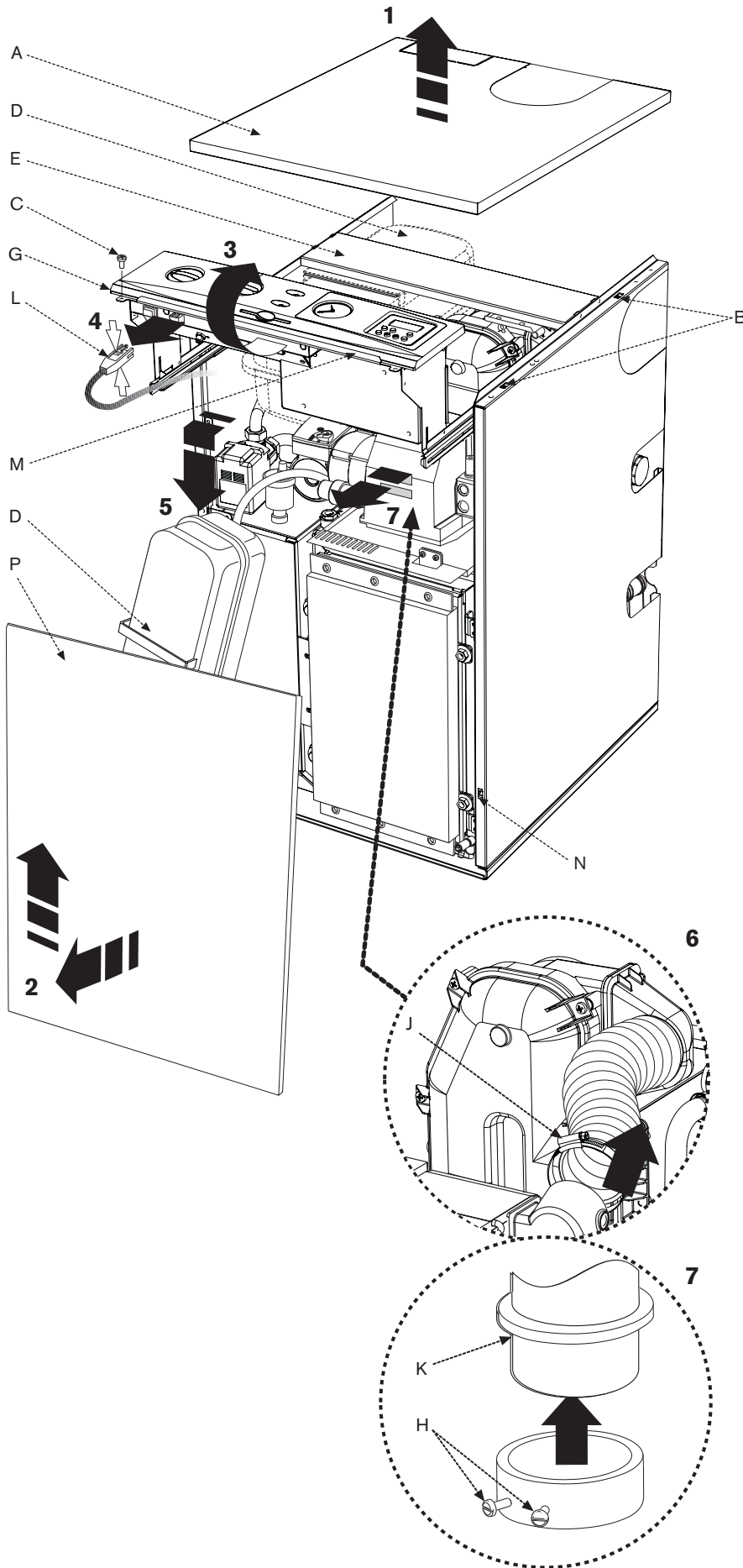

- 1 ▶ Lift the top panel (A) upwards to disengage the ball stud connections (B) and remove.
- 2 ▶ Remove the installation and literature packs.
- 3 ▶ Remove securing screws (C) from each side.
 - ▶ Slide control box (G) out fully.
 - ▶ Pivot control box (G) up and secure in the position shown.
- 4 ▶ Depress locking ears to unplug burner lead (L) from control box (G).
- 5 ▶ Release the expansion vessel (D) from the support bracket (E) and remove taking care not to snag the thermostat capillaries.
 - ▶ Stand the expansion vessel (D) on the floor taking care not to kink or strain the flexible hose.
- 6 ▶ Unscrew burner retainers (H).
 - ▶ Loosen air duct pipe clip (J) and disconnect the air duct pipe.
- 7 ▶ Lift burner assembly up to release the combustion head (K) from heat exchanger and store safely away from the boiler.

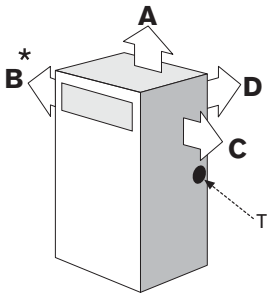

- E - Boiler outer casing
- F - Outer flue tube
- G - Outlet/elbow connection
- H - Outside wall/roof
- K - CF adaptor

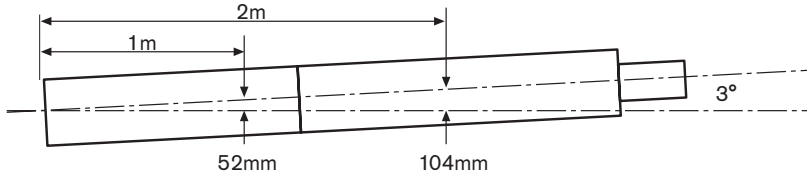
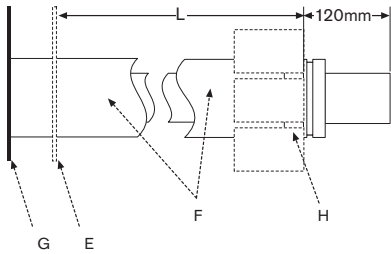
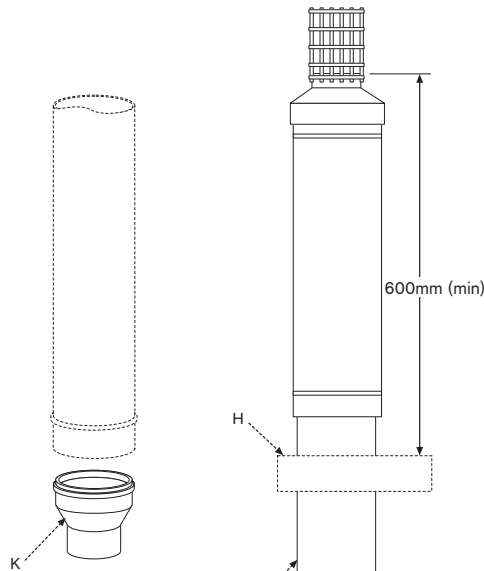

The retaining bracket (M) must be fitted if a flue elbow is used on the boiler flue outlet.

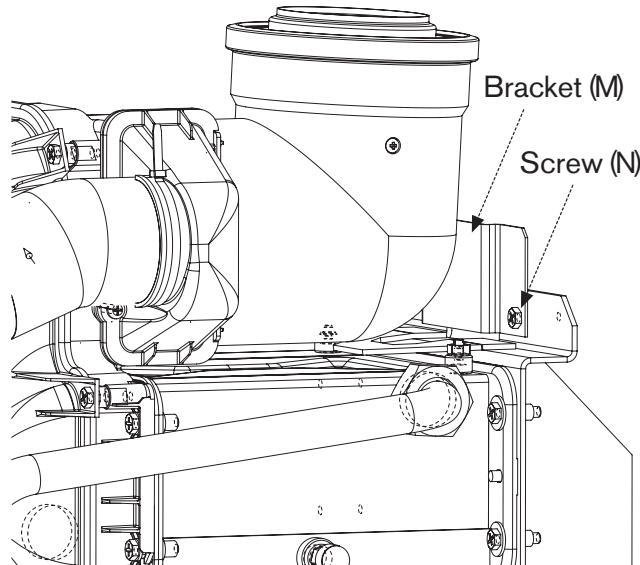

The flue can exit the boiler from outlets A, B, C or D allowing vertical (RS) and horizontal (RS low or high level) flues to be fitted. (CF position 'A' only).

Refer to the separate flue installation instructions supplied with the flue kits available for this boiler:

RS FLUE KITS & COMPONENTS

80/125mmØ (not supplied):

- Horizontal flue kit: Part No. 7 716 190 031
- Vertical flue kit: Part No. 7 716 190 032
- Extension kit (1 metre) x1: Part No. 7 716 190 033
- Inline elbow 90° x1: Part No. 7 716 190 034
- Inline elbow 45° x2: Part No. 7 716 190 035
- Horizontal terminal guard: Part No. 7 716 190 050

CF FLUE KIT 80/100 & 103mmØ (not supplied):

- CF Adaptor Kit: Part No. 7 716 190 036

FLUE TERMINAL GUARD (not supplied):

- Terminal Guard: Part No. 7 716 190 050

INSTALLATION NOTES:

- ▶ When connecting a flue elbow directly to the boiler flue outlet, loosen the flue elbow retaining bracket screws (N) before fitting the flue elbow. Insert the flue elbow with its clamp loosely fitted, then tighten the bracket screws (N). Clamp the elbow when adjusted to its required orientation. If using an extension or horizontal terminal onto the boiler flue outlet, remove the flue elbow retaining bracket (M).
- ▶ Ensure all flue seals are in good condition and seated properly.
- ▶ To ease assembly of flue components, grease seals lightly with the solvent-free grease supplied.
- ▶ Use flue clamps to support the flue system.

IMPORTANT: The boiler is not designed to take the weight of the flue system, this must be supported externally to the boiler.

- ▶ All horizontal flue sections must rise by at least 52mm for each metre away from the boiler to ensure that condensate flows back into the boiler for safe discharge via the condensate waste pipe.
- ▶ The horizontal terminal must be installed at 3° to ensure that the condensate drains back to the boiler whilst also preventing rain ingress down the air duct

* To use the flue outlet 'B' the expansion vessel must be removed and the connection from the boiler capped off. The expansion vessel must be fitted outside the boiler and connected to the right hand side 1" BSP tapings (T).

COMBUSTION CHAMBER

Combustion chamber:

- 1 ▶ Remove the retaining nuts and washers (B).
- ▶ Remove combustion chamber access door (A).
- 2 ▶ Ensure the baffles (C) and baffle retainer (D) are correctly fitted for the boiler output as shown in the plan views below.
- 3 ▶ Refit combustion chamber door (A).
IMPORTANT: Secure with nuts and washers (B) and tighten, using the sequence shown in figure 3a, until the chamber door is firmly secured, do not over tighten the nuts.
- 4 ▶ Unscrew screws (E) and remove flue manifold access cover (F).
- 5 ▶ Check that all the baffles (G) and baffle retainer (H) are correctly fitted to the secondary heat exchanger.

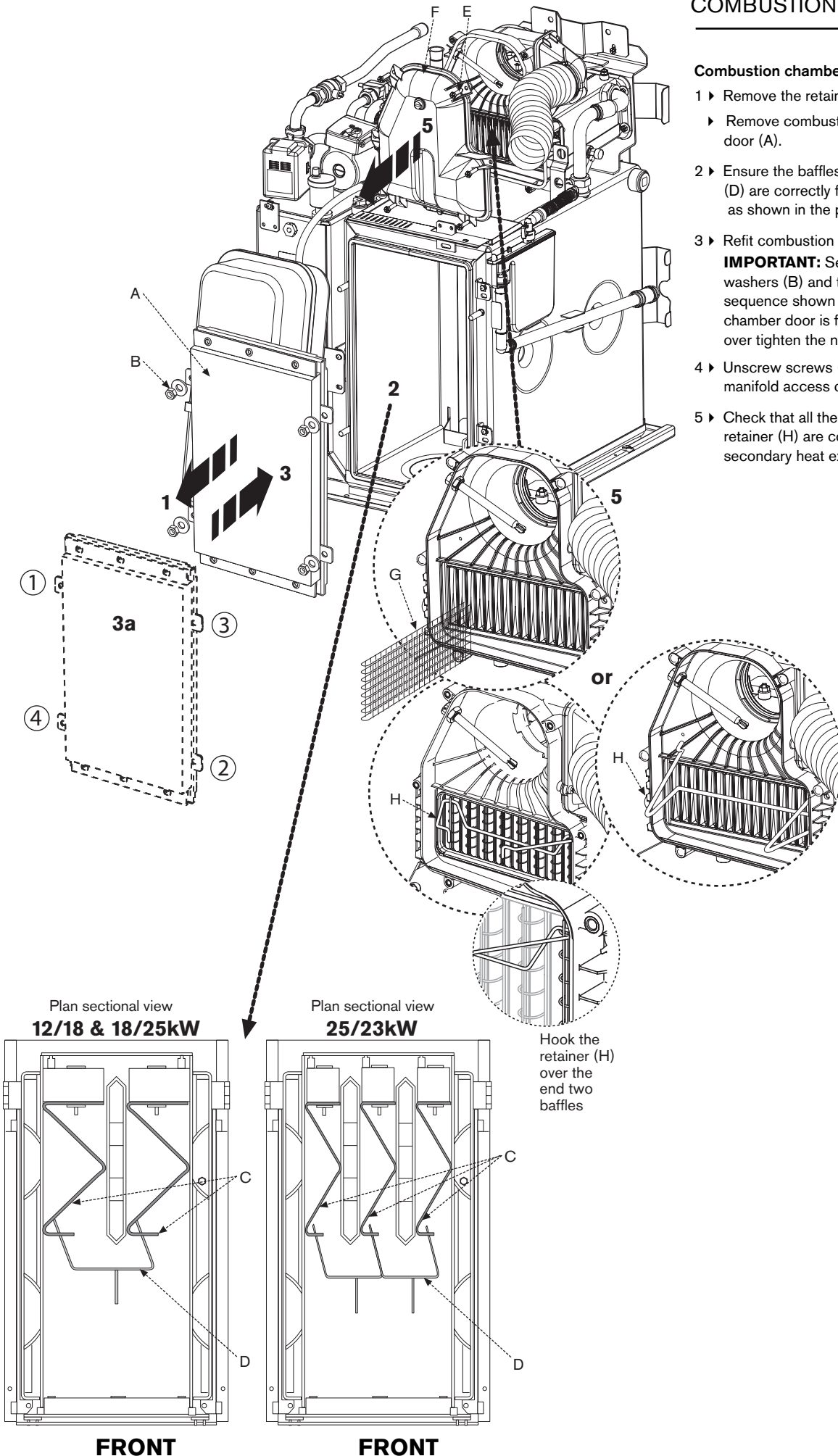

CAUTION: ISOLATE THE OIL & WATER MAINS SUPPLY BEFORE STARTING ANY WORK AND OBSERVE ALL RELEVANT SAFETY PRECAUTIONS.

PIPEWORK CONNECTIONS

- A - CH flow 22mmØ copper (28mmØ on 25/32 models)
- B - DHW flow 22mmØ
- C - DHW water main inlet 15mmØ
- D - CH return 22mmØ copper (28mmØ on 25/32 models)
- E - 10mmØ oil supply connection
- F - Oil isolating valve (10mmØ)
- G - Flexible oil hose*
- H - Flue manifold condensate outlet
- J - Condensate outlet and flexible push fit connect (21.5mmØ) - supplied
- K - Condensate pipe - not supplied
- L - Condensate trap with wall clamp - supplied
- M - Pressure relief (15mmØ)
- N - Optional combined feed and expansion and open vent 1" BSP
- O - Drain
- P - Fixing point for optional return oil pipe

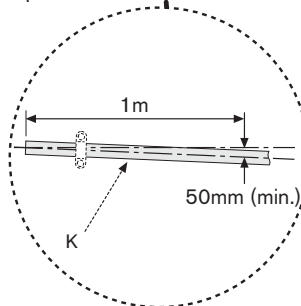
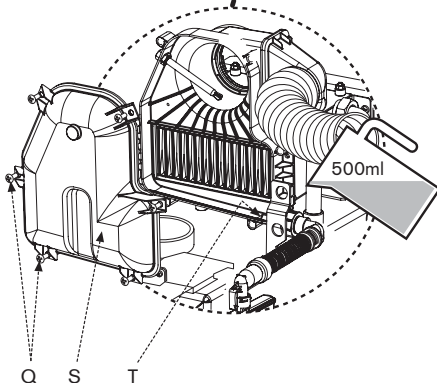
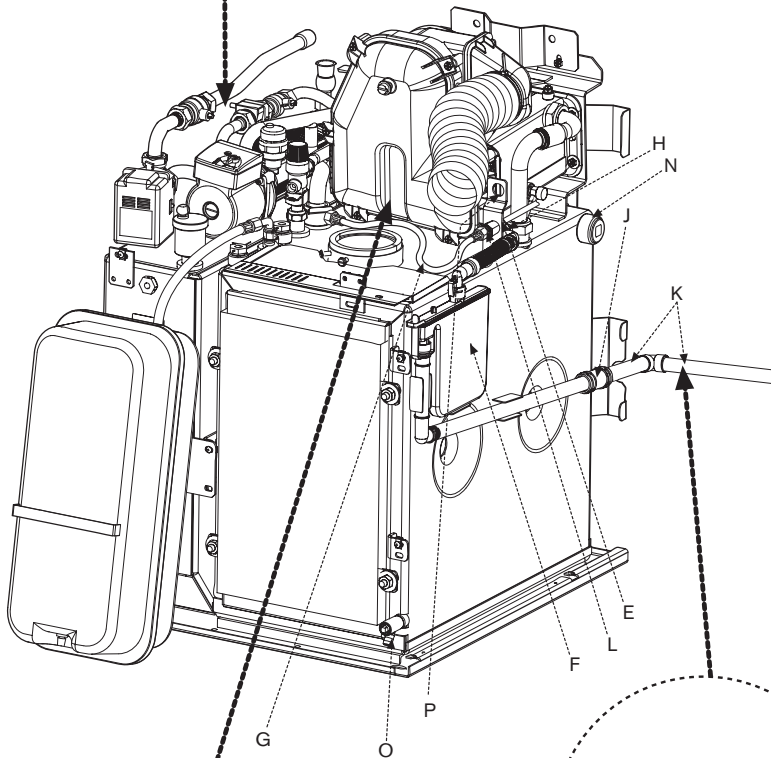
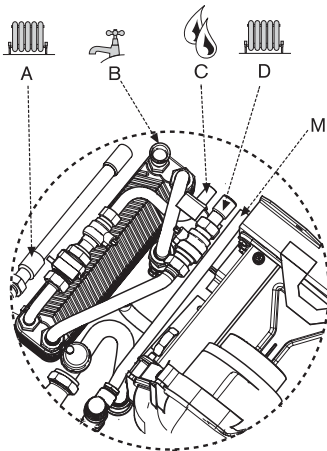

WATER CONNECTIONS:

- ▶ Remove the transit bungs from the pipework connections on the boiler.

NOTE: That surplus water may be present due to factory testing.

- ▶ Remove the central heating flow pipe (A) from its packaging. Grease the flat washer with the grease supplied and fit the pipe and washer onto the isolation valve as shown.
- ▶ Ensure all pipework is clean.
- ▶ Align water pipework and connect, ensuring that the expansion tank and control box fit correctly before permanently connecting the pipework.
- ▶ Check that all unused sockets have been capped.

OIL SUPPLY CONNECTIONS:

- ▶ Route the oil supply pipe (E) along either side of the boiler as required and connect to the isolating valve (F) and ensure the valve is closed.

***NOTE:** Replace flexible hose at annual service to prevent possible oil leakage.

- ▶ Connect the flexible oil hose (G) to the isolating valve (F).

CONDENSATE CONNECTION:

- ▶ Connect 21.5mm polypropylene pipe (K) (not supplied) to the condensate waste pipe flexible push fit connector (J) and terminate to waste.
- ▶ Do not use any solvents, adhesives or lubricants when pushing the pipe into the rubber connector (J).
- ▶ Ensure that the condensate pipe runs away from the boiler at a constant fall of 50mm (min.) for every metre.
- ▶ Seal all condensate pipe joints.
- ▶ Carefully pour 500ml of water into the condensate collection (T) to fill condensate trap.
- ▶ Check the water is running away and the condensate pipework joints are water tight.
- ▶ Check the flue manifold seal is undamaged and seated correctly.
- ▶ Refit flue manifold access cover (S) and secure with screws (Q).

IMPORTANT: The condensate trap must be correctly filled to prevent the possibility of potentially harmful flue products escaping via the condensate pipework.

PRESSURE RELIEF CONNECTION:

- ▶ Connect the pressure relief pipe (M) to a copper discharge pipe (15mmØ min.).

BENTONE
12/18 & 18/25kW

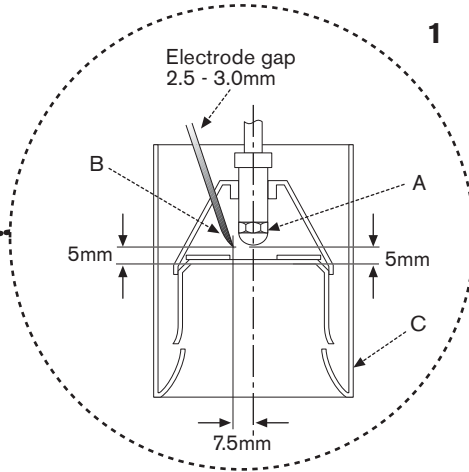
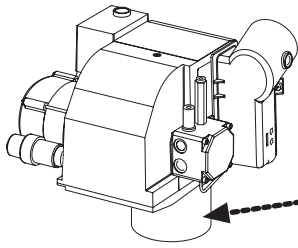

1

CAUTION: ISOLATE THE OIL & WATER MAINS SUPPLY BEFORE STARTING ANY WORK AND OBSERVE ALL RELEVANT SAFETY PRECAUTIONS.

OIL BURNER:

- 1 ▶ Check the nozzle (A) and electrode (B) settings are correct for the relevant burner as shown opposite.
- ▶ Ensure nozzle (A) is aligned centrally within the combustion head (C).
- ▶ Inspect for any visible defects.

RIELLO
12/18, 18/25 & 25/32kW

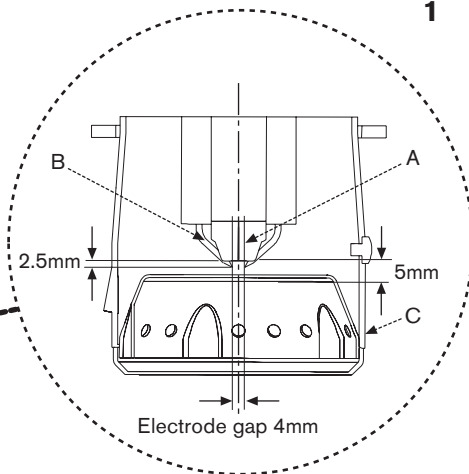
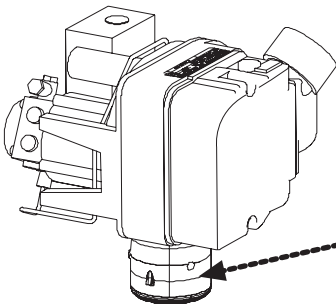

1

IMPORTANT: Whenever replacing the combustion head, ensure that the photocell is lined up with the sight hole.

OIL PUMP:

Connecting the oil pump for a single pipe system:

The pump is factory set for single pipe operation with the flexible oil hose fitted. Check connections before use.

Converting the oil pump for a double pipe system:

- 1 ▶ Check the inlet hose connection.
 - a) DANFOSS BFP 11 L3:
 - ▶ Remove pump front cover (A) ensuring a suitable receptacle is used to catch any oil residue.
 - ▶ Remove changeover screw (B).
 - ▶ Remove horseshoe washer (C).
 - ▶ Refit changeover screw (B).
 - ▶ Refit front cover (A).
 - b) SUNTEC AS47C:
 - ▶ Remove oil pump return plug (2).
 - b) SUNTEC AS47C:
 - ▶ Remove return port plug (2) and insert grub screw (B).
 - c) RIELLO RDB:
 - ▶ Unscrew return plug (2).
 - ▶ Screw in by-pass screw (3).
- 2 ▶ Connect the flexible oil **return** hose (not supplied) between the oil pump and the return line connection, and tighten to secure.

a) DANFOSS BFP 11 L3 OIL PUMP

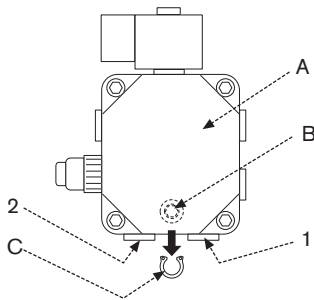

b) SUNTEC AS47C OIL PUMP

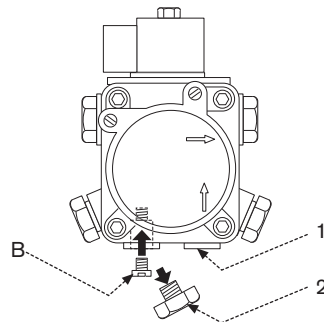

c) RIELLO RDB OIL PUMP

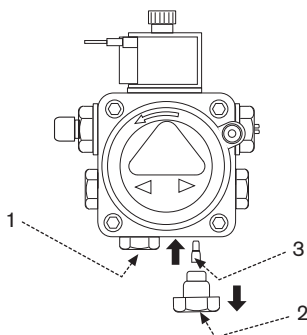

INSTALLATION

REFITTING COMPONENTS

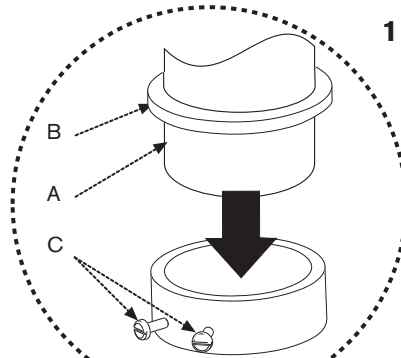

- 1 ▶ Align burner combustion head (A) into boiler housing tube with gasket (B) correctly fitted.
 - ▶ Push firmly down to compress the gasket (B).
 - ▶ Tighten burner retainers (C) sufficiently to ensure a good seal.

IMPORTANT: Ensure the gasket is a good seal between the burner combustion head and the boiler housing to prevent flue gases escaping from the combustion chamber into the room.

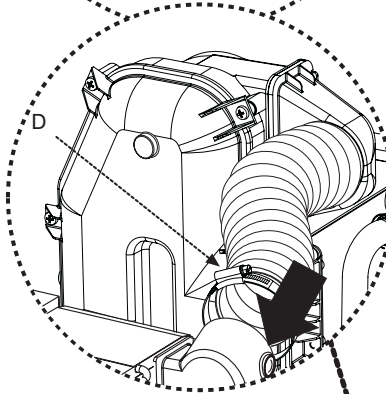

- ▶ Attach air duct and tighten clip (D) to secure to the burner air intake.
- 2 ▶ Refit the expansion vessel (E) onto the support bracket (F) taking care not to kink the flexible hose or snag the thermostat capillaries.
- 3 ▶ Plug burner lead (G) into control box (H).
- 4 ▶ Press in the lugs (I), pivot the control box (H) down and slide into the boiler casing.

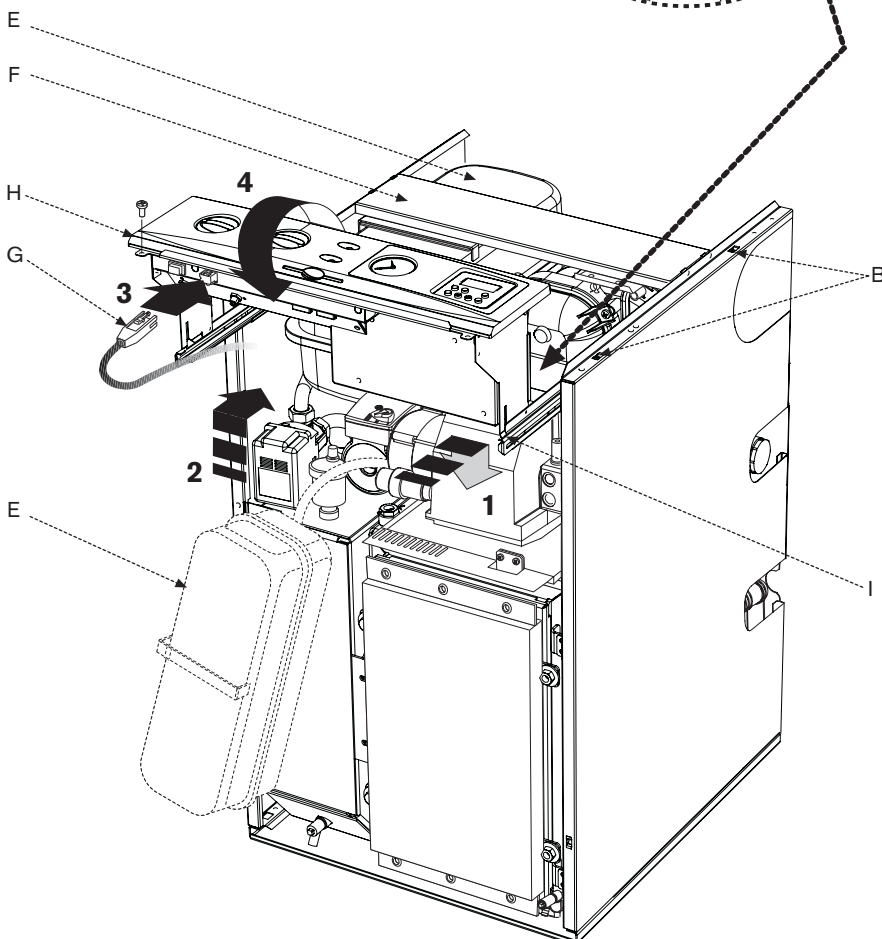

Electrical components:

- 1 Printed circuit board
- 2 Thermostat - boiler high limit
- 3 Thermostat - DHW control
- 4 Thermostat - CH control
- 5 Indicator lamp - power on
- 6 Indicator lamp - lock-out
- 7 Flue manual reset overhear thermostat
- 8 Boiler manual reset overhear thermostat
- 9 Tank manual reset overhear thermostat
- 10 Manual reset - lock-out
- 11 Optional fascia mounted/external programmer
- 12 Burner socket
- 13 Burner plug
- 14 Burner control box
- 15 Flow switch
- 16 Circulating pump
- 17 Diverter valve

Wire colour code:

- br - Brown
- bl - Blue
- gy - Green/Yellow
- r - Red
- w - White
- y - Yellow
- g - Grey
- bk - Black
- or - Orange
- pk - Pink

INSTALLATION

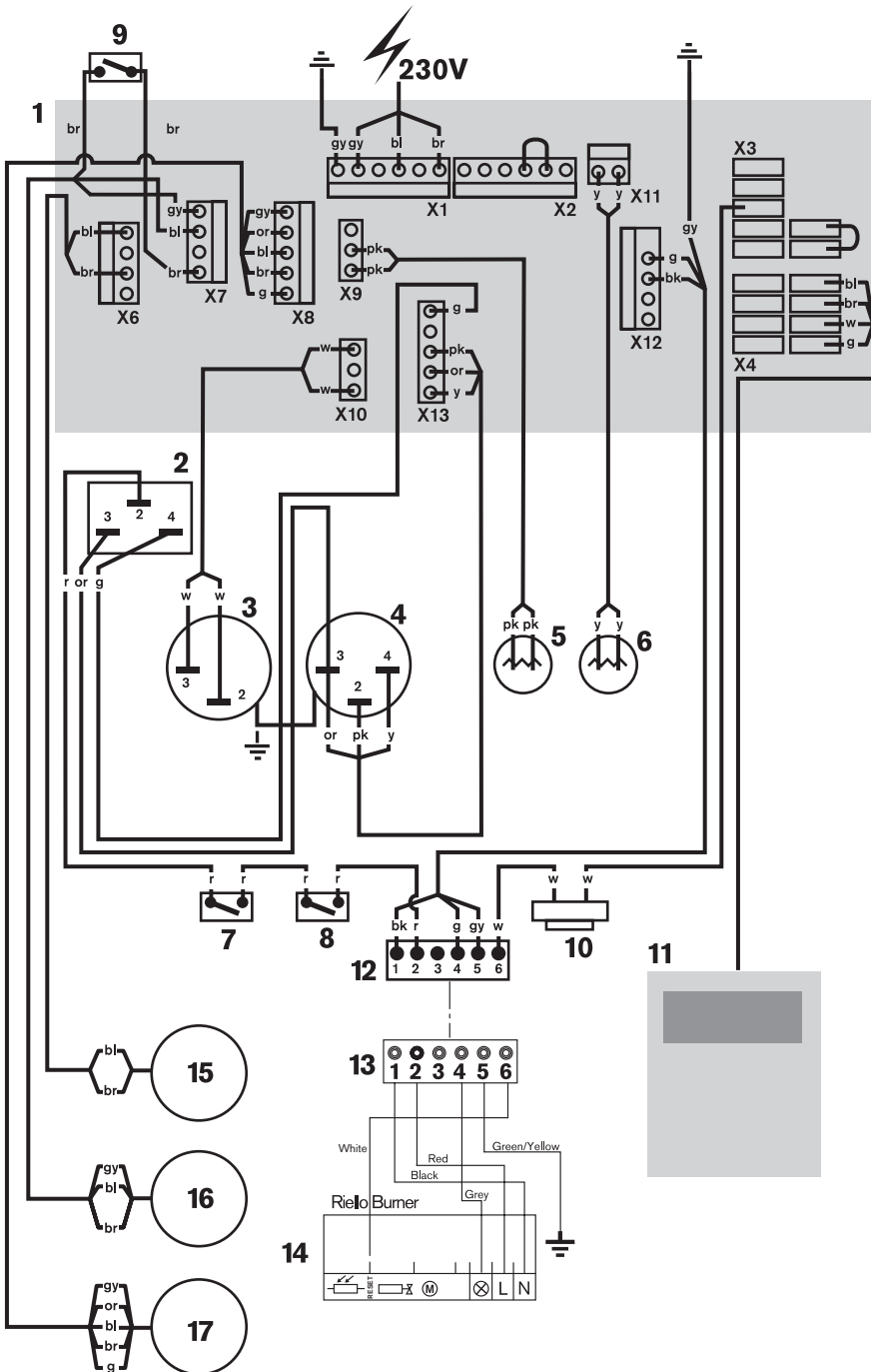



PRE-COMMISSIONING CHECKS - APPLIANCE

CAUTION: ISOLATE THE MAINS SUPPLIES BEFORE STARTING ANY WORK AND OBSERVE ALL RELEVANT SAFETY PRECAUTIONS.

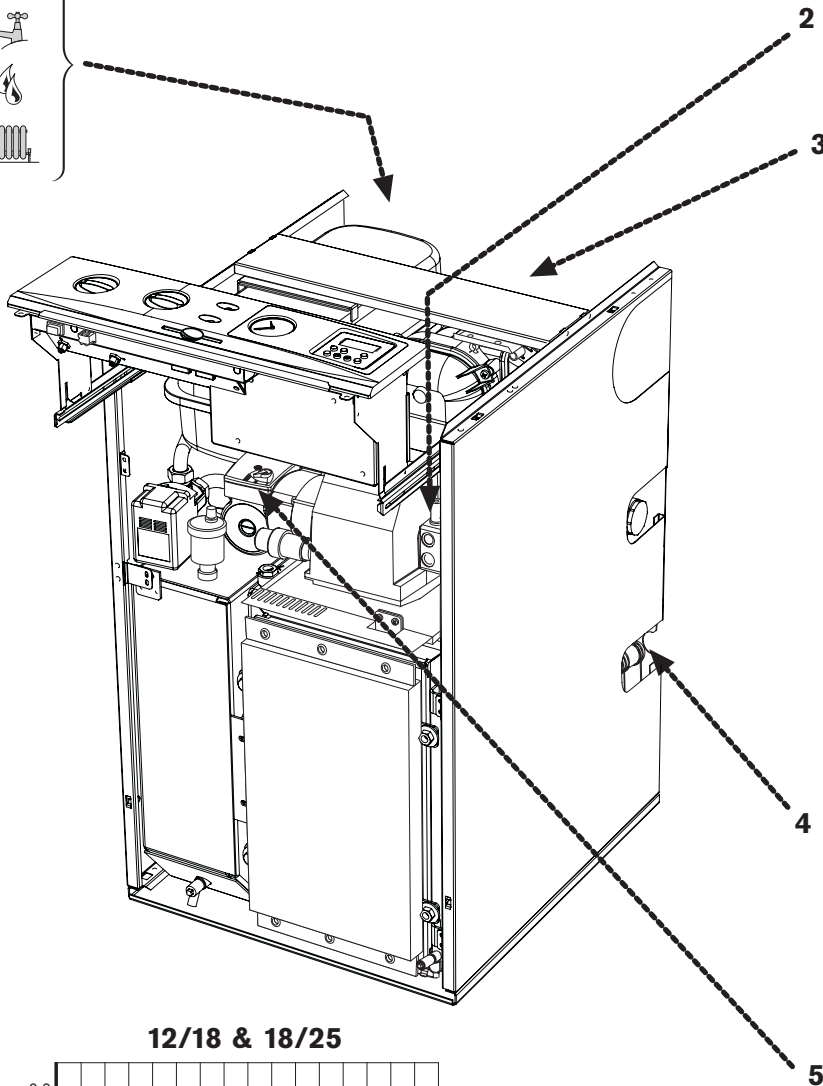

- 1 ▶ Check that the service and water pipes are connected correctly.
 - ▶ Check that all unused sockets are capped.
- 2 ▶ Check that the oil supply is kerosene and that the pipework is connected correctly to the oil pump via the supplied flexible oil hose.
 - ▶ Turn on the main oil supply valve at the tank, check the oil supply pipework and connections. Rectify any leaks.
- 3 ▶ Check the flue is correctly fitted and the connections are secure.
- 4 ▶ Check the condensate pipework is correctly fitted and connected.
 - ▶ Check the condensate trap is filled with water.
- 5 ▶ Check the CH circulating pump is set to 3.

NOTE: Replace flexible hose at annual service to prevent possible oil leakage.

NOTE: The CH circulating pump is preset to number 3 and should not be altered. The diagrams opposite show the pump outputs.

12/18 & 18/25

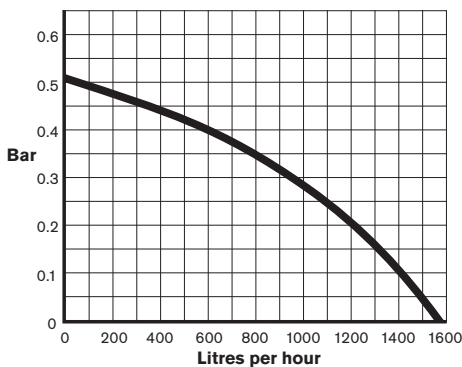

25/32

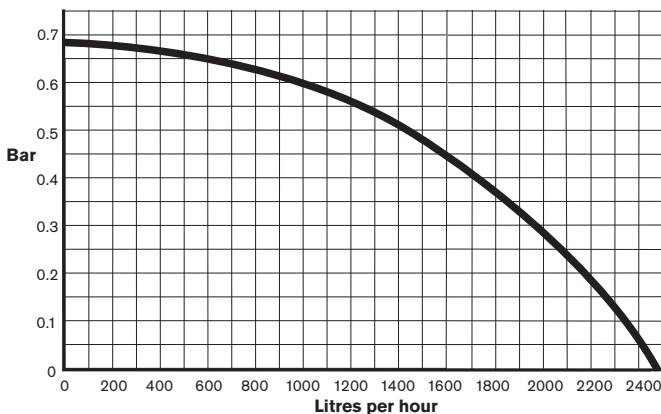

IMPORTANT: If the boiler is not to be commissioned immediately then:
After successfully completing all of the checks and any rectification work, close the water valves, shut off the oil supply and electrically isolate the boiler.
Complete the installation part of the Guarantee Registration Card, and complete a CD10 or equivalent to inform the LABC of the installation.

COMMISSIONING

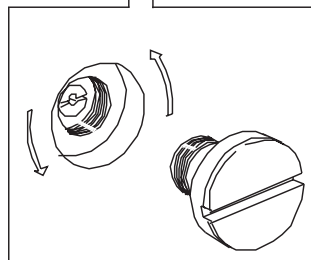
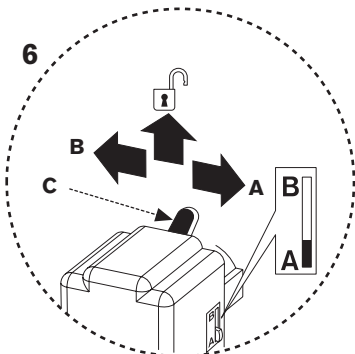
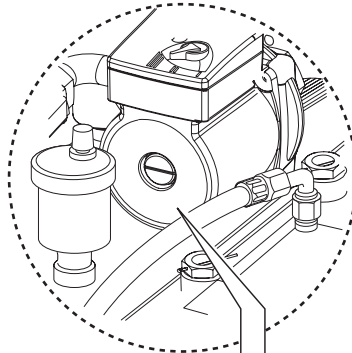
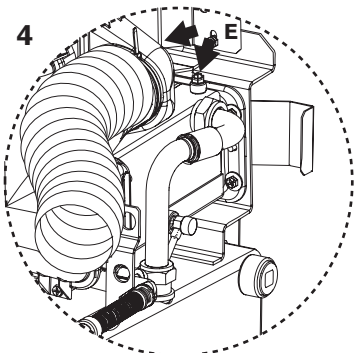
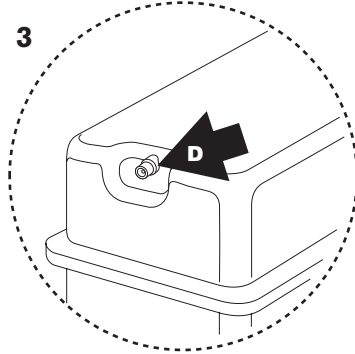
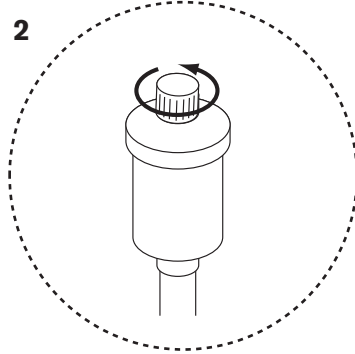
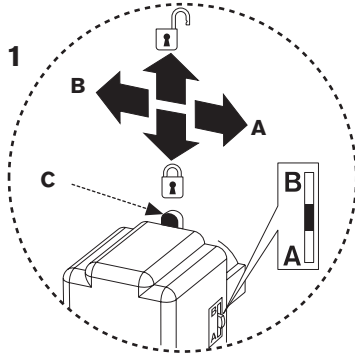

- 1 ▶ Pull lever (C) up and push to the left to move the diverter valve to the mid-position between ports A and B.
 - ▶ Push and hold lever (C) down to lock.
- 2 ▶ Loosen the tank automatic air vent cover.
 - ▶ The pump automatic air vent has a protective cover that must remain in place, this auto air vent needs no adjustment before filling the boiler.
- 3 ▶ Sealed systems only; check and if required, adjust the expansion vessel pressure using the Schraeder type valve (D).

The charge pressure of the built-in 12 litre expansion vessel is 0.5 bar as dispatched, which is equivalent to a static head of five metres.

Total system volume (litres)	Initial system pressure (bar)	Initial charge pressure (bar)
180	0.5	0.5
107	1.0	0.5
138	1.0	1.0

If an extra expansion vessel is fitted to the central heating return, adjust this to the same pressure as the appliance internal expansion vessel, refer to separate instructions supplied with the extra expansion vessel.

- 4 ▶ Open all system and radiator valves.
 - ▶ Turn on the water main stop cock.
 - ▶ Open vented systems only; turn on the water to the system feed and expansion cistern and allow the system to fill.
 - ▶ Sealed systems only; fill the system to between 1 and 2 bar pressure via a WRAS approved filling link. Monitor the pressure gauge during venting and repressurise if required.
 - ▶ Check air is being discharged from the automatic air vents.
 - ▶ Vent all radiators, retighten when completed, check the system and correct any leaks.
 - ▶ Bleed air from both of the secondary heat exchanger air vents (E).
 - ▶ Bleed air from the pump using the pump bleed screw.
- 5 ▶ Sealed systems only; connect a suitable hose to the Heatslave tank drain. Open the drain valve to reduce the system to the correct pressure, then close the drain valve. Ensure safe disposal of the discharge. Rotate the adjustable pointer on the pressure gauge (fitted to the control panel fascia) to record the set system pressure.
- 6 ▶ Check system and rectify any leaks.
 - ▶ Push lever (C) to the left and pull upwards to allow the lever to return position A.
 - ▶ Leave the lever (C) unlocked at position A.

STARTING THE APPLIANCE

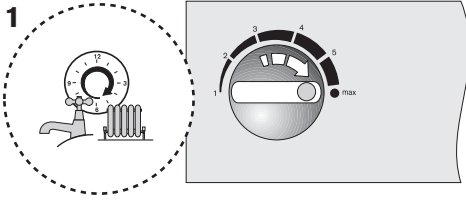

DANFOSS BFP 11 L3 OIL PUMP

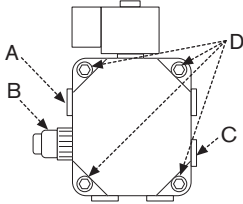

- A - Bleed & pressure gauge port
- B - Pressure adjustment
- C - Vacuum gauge port
- D - Retaining screws - cover

SUNTEC AS47C OIL PUMP

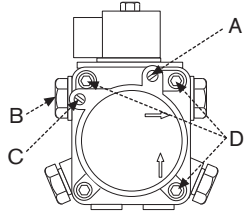

RIELLO RDB OIL PUMP

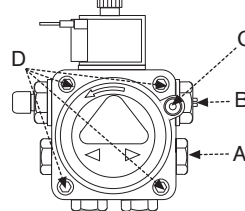

IMPORTANT: Never run the appliance when the appliance/system is unpressurised (sealed systems) or empty.

- 1 ▶ Check the oil supply is correctly fitted and in good working order before turning on the oil supply valves to the boiler.
- ▶ Turn on the main oil supply valve at the tank and draw off at least 2½ litres of oil until a steady flow of clear uncontaminated oil can be seen as follows:

- The oil supply to the boiler should be primed before the burner is operated to avoid unnecessary pump wear.
- The use of an oil suction pump will prime and flush through any oil supply set up simply and easily, alternatively the following procedures can be used.

▶ Single pipe gravity feed systems:

- ▶ Disconnect the flexible oil hose and open the isolating valve to discharge the oil into a suitable container.

NOTE: Replace flexible hose at annual service to prevent possible oil leakage.

- ▶ If a top entry tank has been used the pipework will need to be primed before the oil will discharge under gravity.
- ▶ When completed, close the isolating valve, reconnect the flexible oil hose.

▶ Double pipe sub-gravity feed systems and single pipe suction lift with de-aerator:

- ▶ To prime a de-aerator, disconnect the flexible oil inlet hose (G) from the isolation valve and place in a container of kerosene (H). Connect a spare flexible oil hose (I), to discharge into container (H). Open the isolating valve, turn on the power to the boiler and set the programmer to ON. Prime the de-aerator until there is a steady flow of oil into container (H). Turn off the boiler then reconnect the flexible oil inlet hose (G).

- ▶ Turn on the boiler, the oil level in the de-aerator will drop as the oil is used until the oil is drawn from the tank. If the de-aerator empties and the burner locks out before the oil is drawn from the tank, prime the de-aerator again.

When the oil reaches the pump, bleed the air from the pump as follows:

- ▶ Open the isolating valve and the oil pump bleed port (A) to discharge into a suitable container once the boiler is started up.
- ▶ Switch on the electricity supply to the boiler.
- ▶ Set the programmer to ON for CH and DHW.
- ▶ Turn on the boiler CH control thermostat.
- ▶ Allow the burner to run through to lockout indicated by the illumination of the lockout indicator (F).

If no oil comes out of the port valve A, then re-prime the oil line as detailed above.

- ▶ Wait 2 minutes then press the lockout reset button (E).
- ▶ Repeat the procedure until a steady stream of oil without air, runs from the bleed port, then relock bleed port (A).
- ▶ Switch off the boiler.
- ▶ Remove the oil pump filter, clean with kerosene and refit.

The internal filter is accessed by removing the oil pump cover on the Danfoss BFP 11 L3, Suntec AS47C and Riello RDB.

- ▶ Safely dispose of the container/discharge.

BURNER LOCKOUT

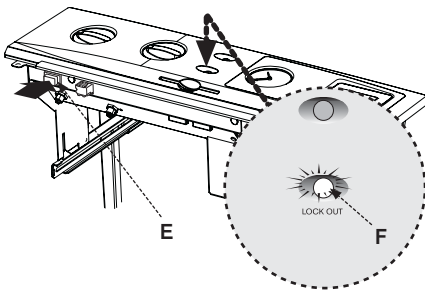

BURNER LOCKOUT RESET BUTTON (E)

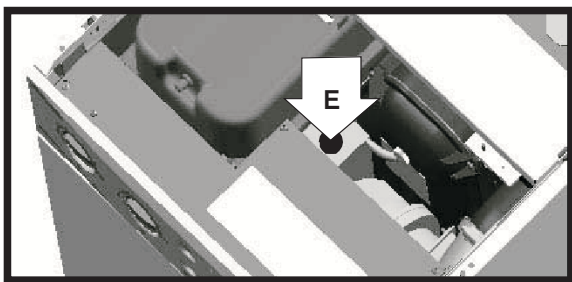

ALTERNATIVE BURNER LOCKOUT RESET BUTTON (E)

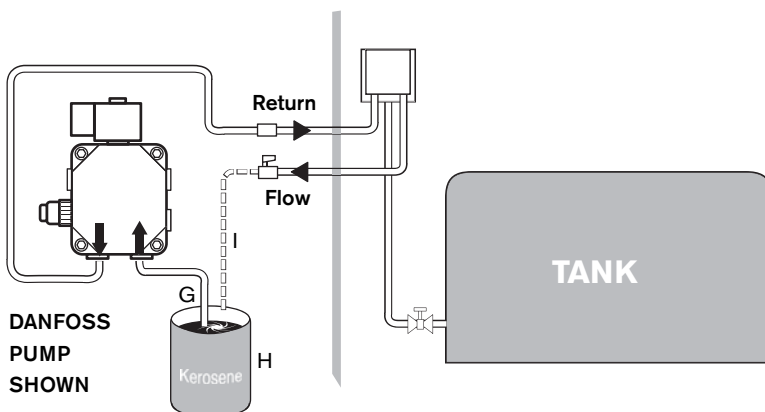

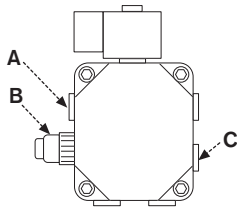
DANFOSS
BFP 11 L3 OIL PUMP

A - Bleed & pressure gauge port B - Pressure adjustment C - Vacuum gauge port

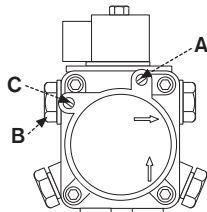
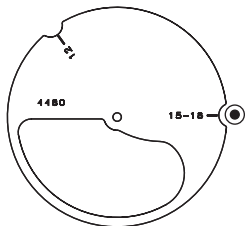
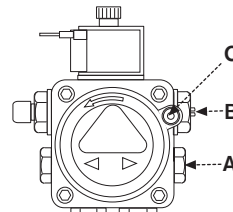
SUNTEC
AS47C OIL PUMP

RIELLO
RDB OIL PUMP

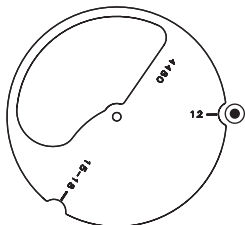
15/18kW

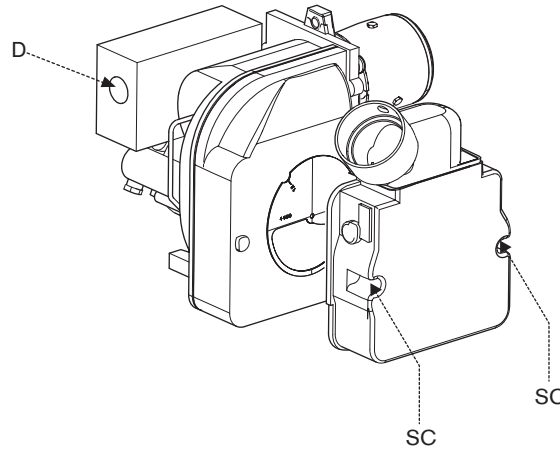

12kW

STARTING THE APPLIANCE

- 2 ▶ Remove plastic cover from the burner casing (there is no plastic cover on the Riello burner).
- ▶ Fit a suitable pressure gauge to port (A) on the oil pump.

IMPORTANT: RIELLO BURNERS.

If changing the burner output, ensure the position of the air damper disk is correct for the desired output. Refer to the table on the following page.

▶ 12/18 - RIELLO RDB 1

Adjust position of the air damper disc to suit the burner output (see chart on the following page), located as shown in the diagram opposite. Access is by removing the two star screws (SC) to release the air inlet manifold.

• 18/25 - RIELLO RDB 2.2

The damper disk should not be moved, as it is required for all three outputs, 18, 21.5 and 25kW.

- ▶ Adjust the air shutter (L) and pump pressure (B) as shown in the table opposite. The burner should ignite following a pre-ignition period of approximately 15 seconds.

NOTE: The MO535 control box has an 11 second delay before the start of the pre-ignition.

Boiler lockout indicator on:

If the burner fails to establish a normal firing pattern or flame failure occurs the flame monitoring photocell mounted in the burner body will alert the burner control box to shut the burner down and provide a safe lockout state indicated by the illumination of the lockout indicator (E).

- ▶ Wait two minutes then press the lockout reset button (D) to initiate another start sequence.
- ▶ Repeat procedure until a flame is established.

3 ▶ Start and run for 3 minutes then switch off.

- ▶ Check for after-spurting from the nozzle, indicated by oil saturation on the combustion head (F).

If after-spurting occurs:

- ▶ Release the burner retainers.
- ▶ Remove the burner, combustion head (F) and electrodes, hold the burner vertical to unscrew the nozzle and fill the nozzle holder with oil.
- ▶ Refit nozzle, electrodes, combustion head (F) and the burner.
- ▶ Restart and run for 3 minute intervals until after-spurting stops.

4 ▶ Start and run for 20 minutes.

- ▶ Remove sampling point plug (K) to check the smoke reading is between 0-1. If the smoke level is above 1, check the combustion settings are correct and the oil nozzle is in good condition.

NOTE: Smoke readings may be inaccurate until the smoke from burning organic binder in the access door insulation has ceased.

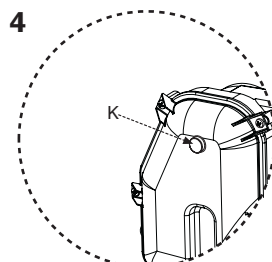
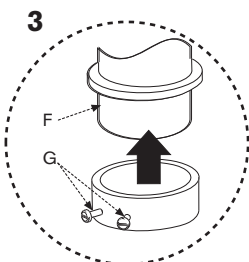
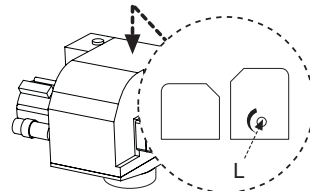
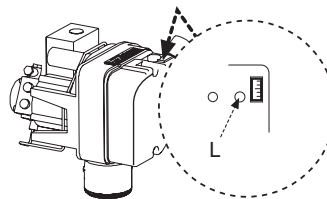
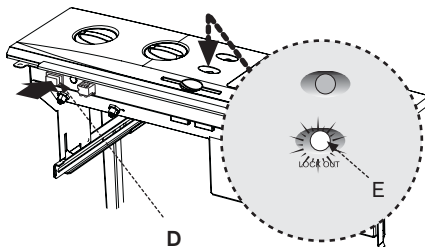

**DANFOSS
BFP 11 L3 OIL PUMP**

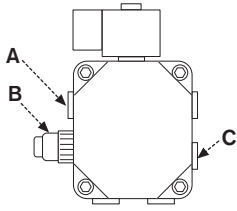

**SUNTEC
AS47C OIL PUMP**

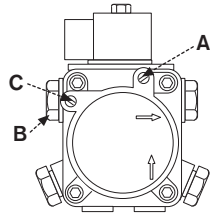

**RIELLO
RDB OIL PUMP**

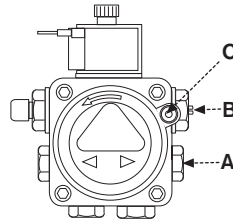

A - Bleed & pressure gauge port B - Pressure adjustment C - Vacuum gauge port

- ▶ Check the CO₂ levels and adjust the air shutter (L) setting according to the table opposite.
- ▶ Check the flue gas temperature is close to the values shown in the table.

If the flue gas temperature is too high and the baffles are correctly fitted, then reduce the oil pump pressure (B) 5-10 p.s.i. to compensate for nozzle variations.

- ▶ Turn off the electrical supply.
- ▶ Isolate the oil supply to the burner.
- ▶ Remove the oil pressure gauge.
- ▶ Refit the blanking plug (A).
- ▶ Check and rectify any oil leaks.

- 5 ▶ Switch on the oil supply.
- ▶ Switch on the electrical supply.
 - ▶ Restart the boiler and run for 5 minutes.
 - ▶ Recheck the CO₂ levels and if required, adjust the air shutter setting (L) to obtain the correct CO₂ level.

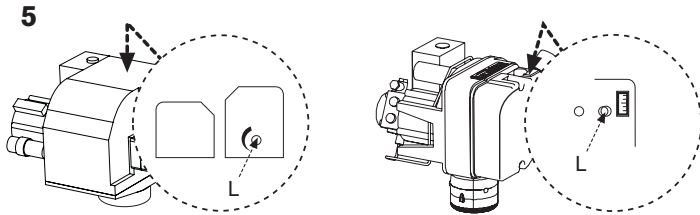

**NOMINAL BOILER RATING AT NORMAL OPERATING TEMPERATURE
USING 28sec KEROSENE:**

NOZZLE	OIL PUMP PRESSURE (p.s.i.)	FUEL FLOW RATE		APPROX FLUE GAS TEMP. (°C)	%CO ₂	APPROX. AIR SETTING	AIR DAMPER DISC	APPLIANCE			
		Kg/h	l/h					INPUT		OUTPUT	
								kW	Btu/hr	kW	Btu/hr
12/18 - Bentone Sterling 40 Burner:											
0.35 80°SR	115	1.04	1.32	66	11.5	2.5	N/A	12.4	42300	12	40900
0.45 80°S	115	1.29	1.63	70	12.0	4.5	N/A	15.5	52900	15	51200
0.50 80°ES	140	1.55	1.96	73	12.5	5.25	N/A	18.6	63500	18	61400
18/25 - Bentone Sterling 50 Burner:											
0.50 80°EH	130	1.56	1.98	72	11.5	4.25	N/A	18.6	63300	18	61400
0.55 80°EH	145	1.86	2.36	79	12.0	6.0	N/A	22.2	75100	21.5	73400
0.65 80°EH	150	2.17	2.75	82	12.5	8.0	N/A	25.8	87900	25	85300
12/18 - Riello RDB 1 Burner											
0.35 80°SR	105	1.04	1.32	64	12.0	4.5	12kW	12.4	42300	12	40900
0.45 60°ES	120	1.29	1.63	67	12.0	3.0	15-18kW	15.5	52900	15	51200
0.50 60°ES	125	1.55	1.96	72	12.5	4.5	15-18kW	18.6	63500	18	61400
18/25 - Riello RDB 2.2 Burner											
0.50 60°ES	125	1.56	1.98	75	11.5	2.0	18-25kW	18.6	63300	18	61400
0.65 60°ES	120	1.86	2.36	78	12.0	3.0	18-25kW	22.2	75100	21.5	73400
0.75 60°ES	115	2.17	2.75	84	12.5	4.5	18-25kW	25.8	89700	25	85300
25/32 - Riello RDB 2.2 Burner											
0.75 60°ES	105	2.15	2.72	78	11.5	3.0	N/A	25.5	87040	25	85300
0.75 60°ES	140	2.45	3.10	80	12.0	4.0	N/A	29.1	99200	28.5	97200
0.85 60°ES	150	2.75	3.48	83	12.5	5.0	N/A	32.7	111400	32	109200

STARTING THE APPLIANCE

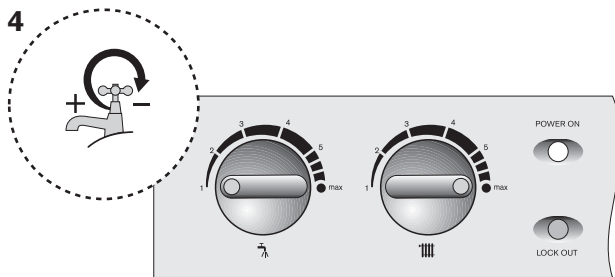
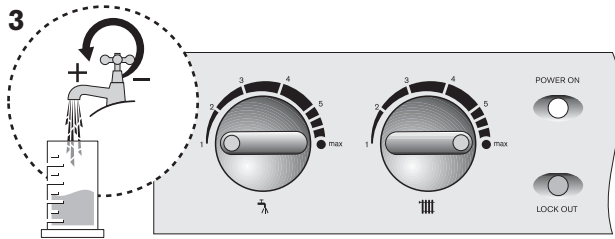
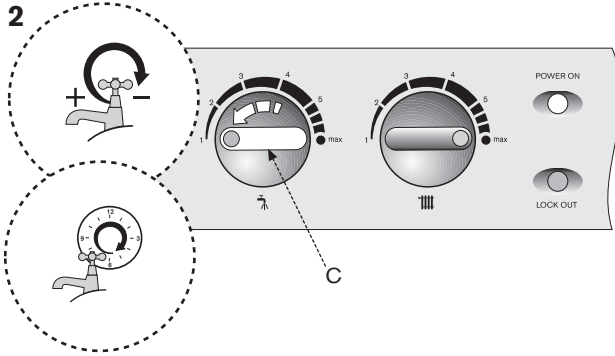
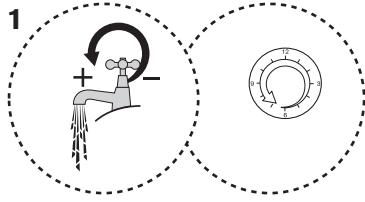

Domestic hot water:

- 1 ▶ Set the CH/DHW programmer to OFF.
- ▶ Fully open a hot water tap.

The burner should be OFF and the circulating pump ON.

- 2 ▶ Close the hot water tap.
 - ▶ Set the DHW thermostat control (C) to minimum as shown.
 - ▶ Set the programmer to DHW ON.

The burner should be ON with the circulating pump to heat the water in the Heatslave tank.

When the minimum set temperature is reached the burner and circulating pump will switch off.

- 3 ▶ Fully open a hot water tap.

The burner should be OFF and the circulating pump ON. The burner will turn ON when the DHW thermostat calls for heat.

 - ▶ Check the water flow rate using a suitable measuring container;
 - 12/18kW 15 litres/min*
 - 18/25kW 18 litres/min*
 - 25/32kW 22 litres/min*

** Manually regulate using the water main inlet isolating valve on the boiler.*

- 4 ▶ Fully close the hot water tap.
 - ▶ Check the burner and circulating pump** switch off.

***The high limit thermostat may activate pump overrun until the correct boiler temperature is restored.*

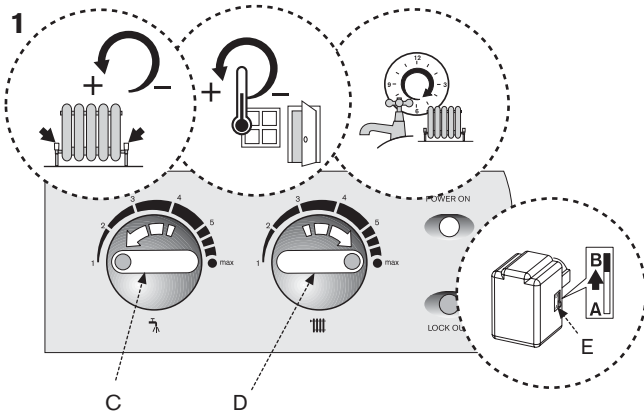

Central heating:

- 1 ▶ Open all radiator valves.
- ▶ Set room thermostat to maximum.
- ▶ Set programmer to ON for CH.
- ▶ Turn the DHW thermostat control (C) fully anti-clockwise.
- ▶ Turn the CH thermostat control (D) to max.

The burner should be ON with the circulating pump. The diverter valve (E) should open to port B for CH.

- ▶ Ensure all radiators are heating up evenly and balance the system to the temperature difference required across the heating flow and return relevant to the heating load.

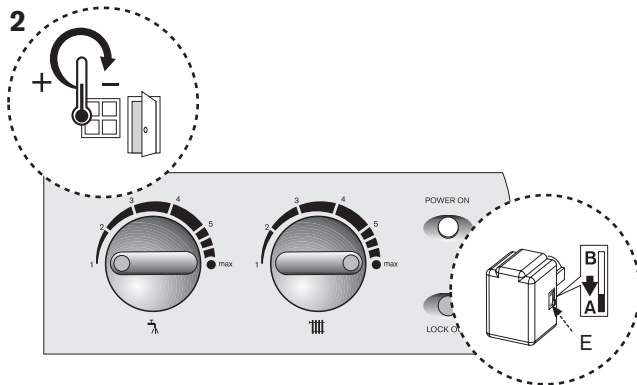

- 2 ▶ Set the room thermostat to minimum. The burner and circulating pump should be off. The diverter valve (E) should return to port A for DHW (default).

Domestic hot water & central heating:

- 3 ▶ Set the room thermostat to maximum.
- ▶ Set the programmer to ON for DHW & CH.
- ▶ Turn the DHW thermostat control (C) fully anti-clockwise.
- ▶ Set the CH thermostat control (D) to max.

The burner should be ON with the circulating pump. The diverter valve (E) should open to port B for CH.

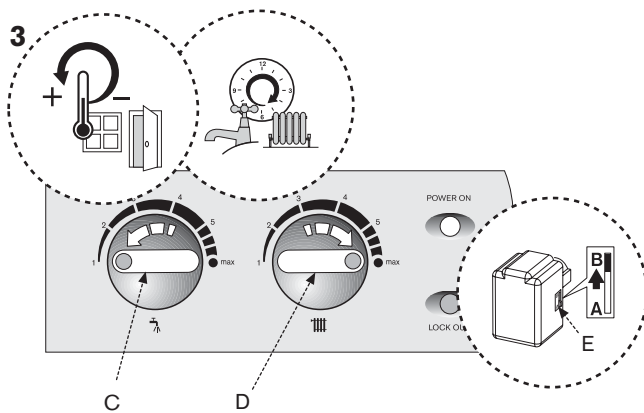

- 4 ▶ Set the DHW thermostat control (C) to max. The diverter valve (E) should move to port A and divert the flow to the Heatslave tank.

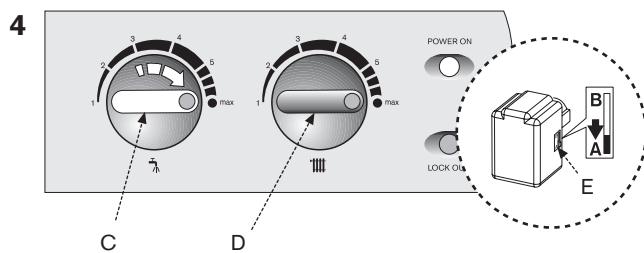

IMPORTANT: Debris from the system can damage the boiler and reduce efficiency. Failure to comply with the guidelines for the use of water treatment with the appliance will invalidate the appliance warranty.

FLUSHING (Central Heating):

- 1 ▶ Switch off the boiler.
 - ▶ Open vented systems only: turn off the water to the system header tank.
 - ▶ Open all radiator valves/drain cocks (C) and drain the system while the appliance is hot.
 - ▶ Close drain cocks (C).
- 2 ▶ Add a suitable flushing agent and refill the system at the correct strength for the system condition in accordance with the manufacturer's instructions.
 - ▶ Vent the boiler (there are two vent points (A) at the top of the secondary heat exchanger. Only one may be in use, the other may be obscured by side fluing. Always vent (A) and the vent screw (B) on the pump and all radiators.
 - ▶ Run the boiler/system at normal operating temperature for the time stated by the flushing agent manufacturer.
- 3 ▶ Drain and thoroughly flush the system and boiler (C) to remove the flushing agent and debris.

INHIBITOR (Central Heating):

- 4 ▶ Check drain cocks and manual air vents are closed and all radiator valves are open.
- 5 ▶ Add a suitable inhibitor, (or combined inhibitor/anti-freeze if the system is exposed to freezing conditions) to the heating system in accordance with the manufacturers instructions.

The inhibitor or combined inhibitor/anti-freeze must not cause damage to the materials within the boiler (mild steel, stainless steel, copper and brass) and any other materials/components within the system.

- ▶ Open vented systems only: turn on the water to the system header tank and allow the system to fill.
- ▶ Sealed systems only: fill the system to between 1 and 2 bar via a WRAS approved filling loop. Check the system pressure during venting and repressurise if necessary.

- 6 ▶ Vent the boiler (there are two vent points (A) at the top of the secondary heat exchanger. Only one may be in use, the other maybe obscured by side fluing. Always vent (A) and the vent screw (B) on the pump and all radiators; retighten vents when complete.
- 7 ▶ Record the date when the inhibitor was added to the system on the guarantee card.

NOTE: The concentration level of inhibitor in the system should be checked every 12 months or sooner if system content is lost.

The addition of sealing agents to the system water is not advised as this can cause problems with deposits left in the heat exchanger and invalidate the appliance and heat exchanger warranty .

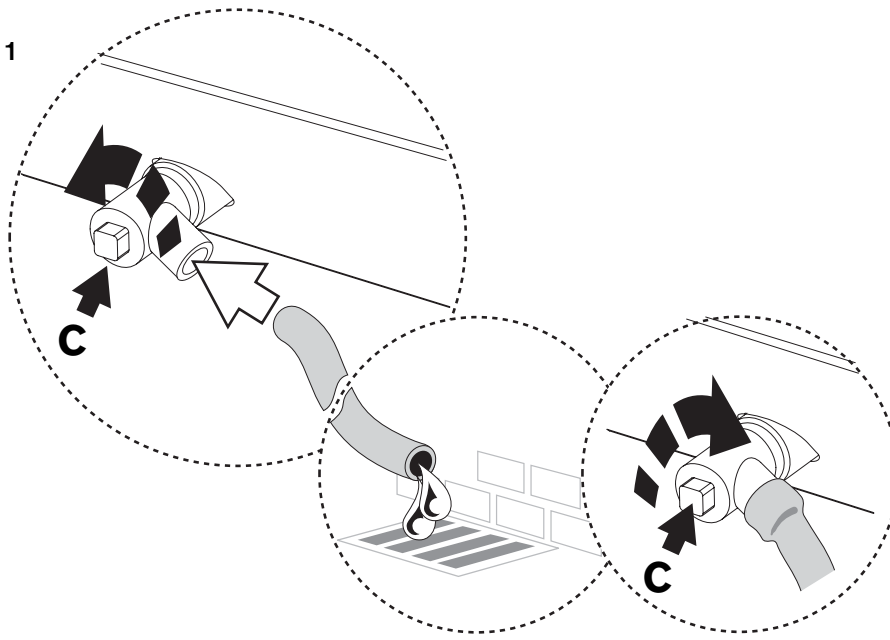

2 & 6

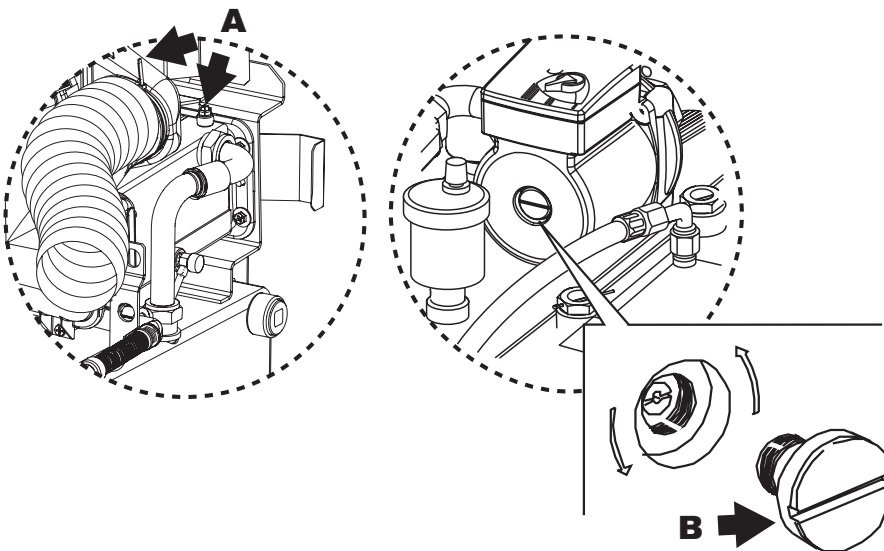

3

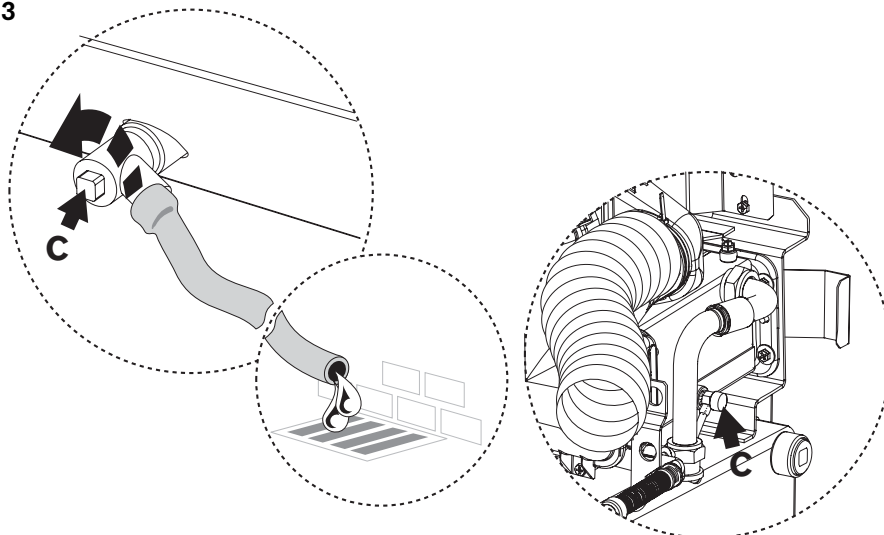

FINISHING COMMISSIONING - APPLIANCE

- 1 ▶ Release support lugs (H) to pivot the control box (A) down and into the boiler.
▶ Secure with screws (B).
- 2 ▶ Locate top edge of panel (C) onto the top supporting ledge (D) on the boiler.
▶ Locate the ball stud connections (E) at the base of the front panel (C) and push towards the boiler to secure.
- 3 ▶ Locate the top panel (F) onto the ball stud connections (G) and press down to secure.
Always apply pressure at the edges of the boiler panels when securing to avoid accidental damage.

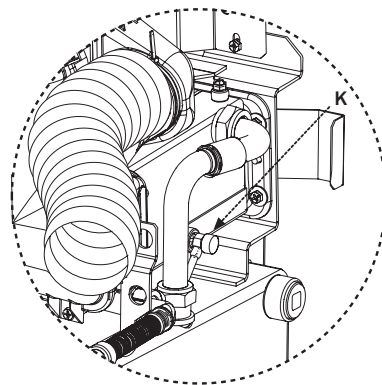
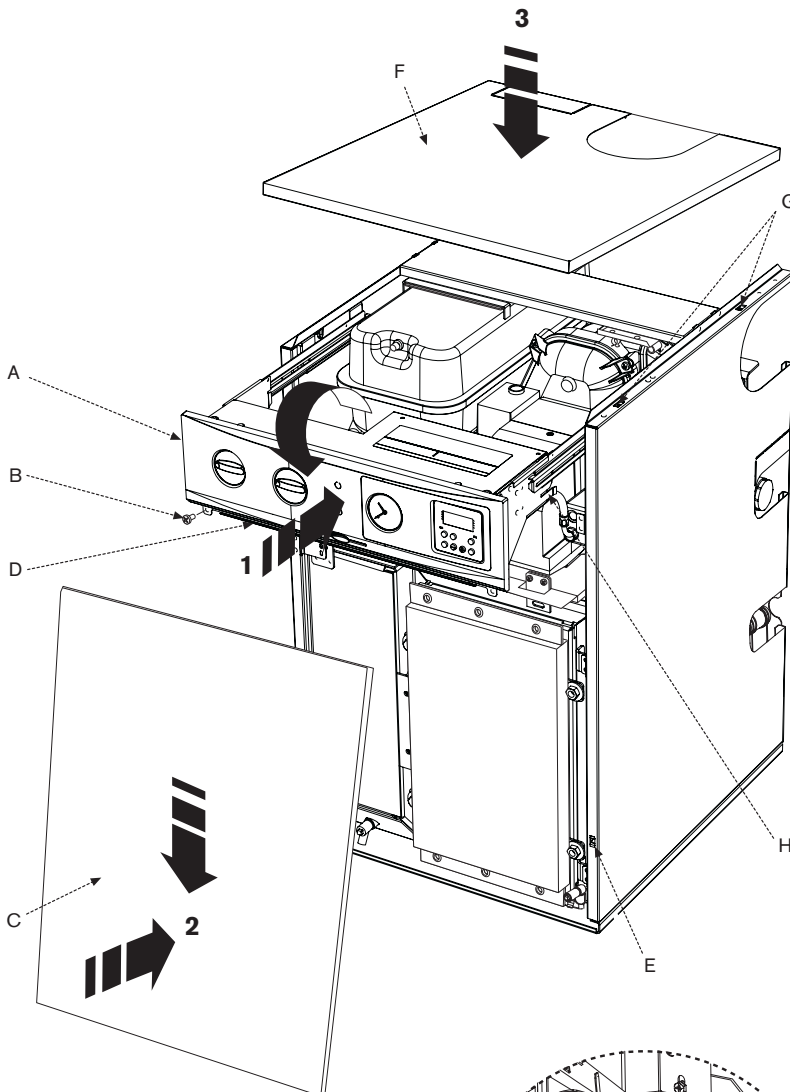

Handover:

- ▶ Complete the Guarantee Registration Card, Combustion Record (at the rear of this manual) and CD11 or an equivalent commissioning form.
- ▶ Set up the controls and show the user how to operate all the controls shown in the User Guide and all system controls.
- ▶ Where applicable, instruct the customer how to repressurise the system.
- ▶ If the appliance is unused and exposed to freezing conditions, shut off all the mains supplies and drain the system and boiler.

NOTE: Release drain point (K) to drain the secondary heat exchanger.

CAUTION: ISOLATE THE WATER, ELECTRICITY AND OIL MAINS SUPPLIES BEFORE STARTING ANY WORK AND OBSERVE ALL RELEVANT SAFETY PRECAUTIONS.

Routine servicing:

To maintain efficient boiler operation, the following should be carried out at least once a year:

- ▶ Carry out a pre-service check and note any operational faults:

▶ Pre-Service Check:

- 1 ▶ Lift the top panel (A) upwards to disengage the ball stud connections (B) and remove.
- 2 ▶ Pull base of front panel (P) away from the boiler to disengage ball stud connectors (N).
- ▶ Lift front panel (P) upwards off the supporting ledge (M) and store safely away from the working area.

- 3 ▶ Remove securing screws (C) from each side of control box (G).
 - ▶ Slide control box (G) outwards to its full extent.
 - ▶ Pivot control box (G) upwards and secure in the service position as shown.

Operate the appliance and system and note any faults which may need to be corrected during the service.

- ▶ Switch off and electrically isolate the boiler.
- 4 ▶ Depress locking ears and unplug burner lead (L) from control box (G).
 - 5 ▶ Release the expansion vessel (D) from the support bracket (E) and remove taking care not to kink or strain the flexible hose or snag the thermostat capillaries.
 - ▶ Stand the expansion vessel (D) on the floor taking care not to kink or strain the flexible hose.
 - 6 ▶ Loosen clip (J) to detach air duct.
 - 7 ▶ Unscrew burner retainers (H) to release the burner combustion head (K).
 - ▶ Lift burner away, taking care not to over strain the flexible oil hose/s or connections.

See the following instructions for detail of some of the service requirements listed below:

- ▶ Check and clean the burner.
- ▶ Replace burner nozzle and flexible oil hose/s.
- ▶ Check and clean the baffle retainers.
- ▶ Check and clean the baffles.
- ▶ Check and clean the heat exchangers surfaces.
- ▶ Check the combustion chamber access door insulation board.
- ▶ Check that the flue system is unobstructed and clean as necessary.
- ▶ Clean or replace all oil filters.
- ▶ Check that the condensate system is not obstructed, clean and refill the condensate trap as necessary.

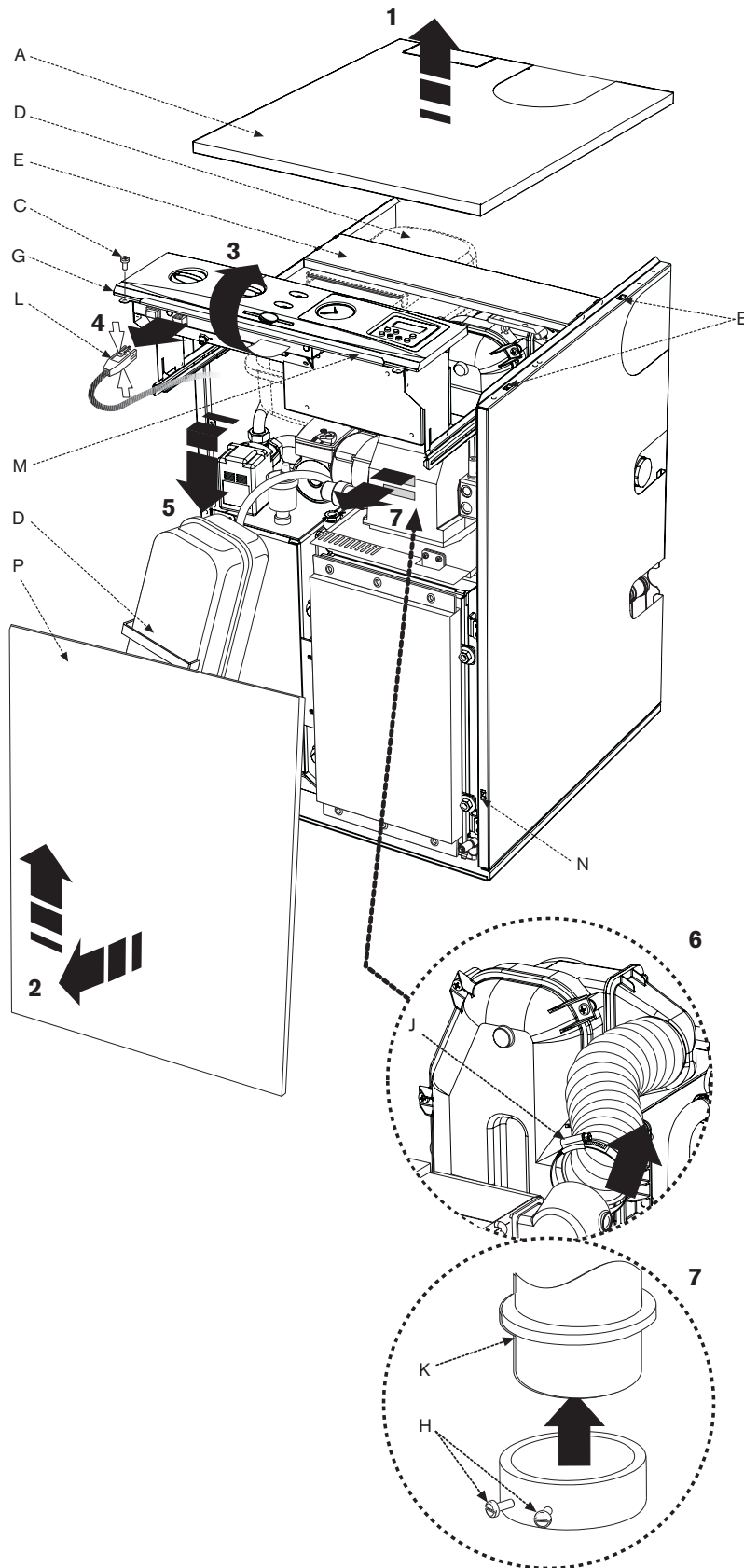

**BENTONE
STERLING 40 & 50**
12/18
18/25

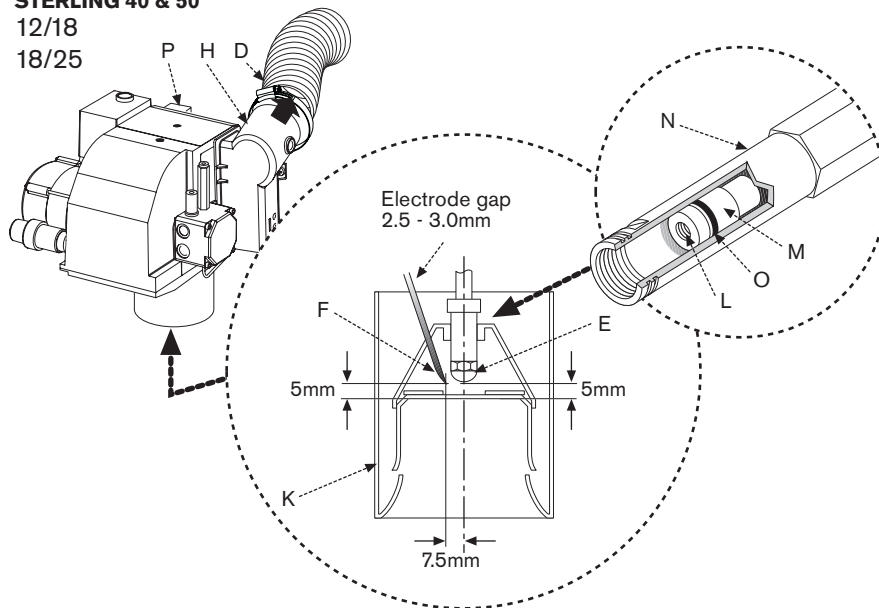

1 Clean the Burner:

- ▶ Remove the air intake cover (H) and clear any debris from the air intake and air damper.
- ▶ Disassemble the burner to allow access to the fan impeller.
- ▶ Check the condition of the gaskets between these parts and replace if necessary.
- ▶ Note the position of the air damper adjustment and check the air damper moves freely.
- ▶ Clean both sides of the fan impeller and remove any debris from the burner housing.
- ▶ Check that the impeller rotates freely.
- ▶ Reassemble the components.
- ▶ Remove the combustion head (K) and thoroughly clean any deposits.
- ▶ Remove the nozzle (E).

**2 Bentone Sterling 40 & 50
12/18 & 18/25 Inspection of Mechanical Shut-off Valve:**

- ▶ Fasten an M5 screw, with a minimum length of 30mm, into the threaded hole (L) and pull the screw to withdraw the check valve (M).
- ▶ Check that the nozzle holder (N) is clear of any debris and clean if necessary.
- ▶ Check that the three holes in the check valve (M) are clear of any debris. Check the condition of the 'O' ring (O). Discard the check valve if the holes cannot be cleared, if the unit is defective or if the 'O' ring is damaged and replace with a new one.
- ▶ Refit the check valve.

**RIELLO
RDB 1 & 2.2**
12/18
18/25
25/32

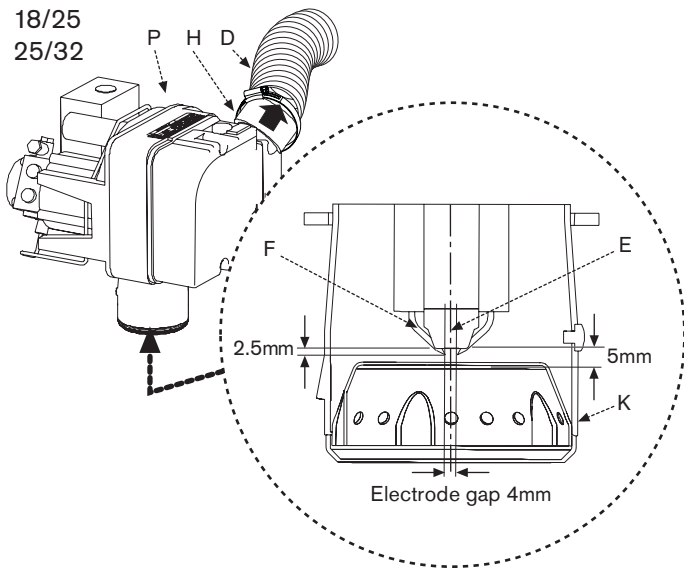

**Riello RDB 1 & 2.2
12/18, 18/25 & 25/32**

- ▶ Check the nozzle holder is clear of any debris and clean if necessary.

ALL MODELS

- ▶ Fit a new oil atomising nozzle (E).

DO NOT dismantle the nozzle and DO NOT clean the nozzle tip.

- ▶ Check the electrodes (F) and reset if necessary as shown opposite.
- ▶ Refit the combustion head. Check that the nozzle (E) lies centrally in the combustion head and the head settings are as shown. Ensure that the photo cell is lined up with the sight hole.
- ▶ Withdraw the photocell (P) from its housing and wipe clean.
- ▶ Remove the oil pump internal filter, clean in kerosene and reassemble.

The internal filter is accessed by removing screws (A) and the oil pump cover (B) on the Danfoss BFP 11 L3, Suntec AS47C and Riello RDB.

IMPORTANT

- ▶ Replace the standard flexible oil hose/s at every annual service to prevent the possibility of oil leakage.

**DANFOSS
BFP 11 L3 OIL PUMP**

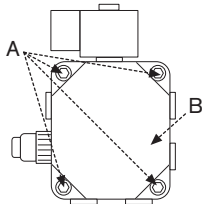

**SUNTEC
AS47C OIL PUMP**

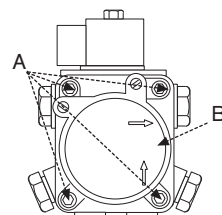

**RIELLO
RDB OIL PUMP**

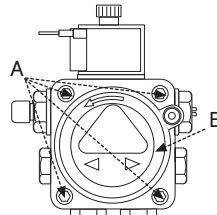

- A - Retaining screws - cover
- B - Cover - oil pump

- ▶ Reassemble the burner components.
- ▶ Check the sponge O-ring seal located around the combustion head and replace if necessary.

This seal must be in good condition since failure will cause flue gases to escape into the room.

SERVICING & SPARES

External oil filter:

- ▶ Remove the paper element from the external oil filter and replace it. If the filter contains a washable element, thoroughly clean in kerosene and reassemble into the filter.

Clean the boiler:

Manifold access:

- ▶ Release screws (A) to remove the flue manifold access cover (B) and clear any debris.
- ▶ Check the flue system and clean if necessary.
- ▶ Remove the baffle retainer (H) and baffles (I) from the secondary heat exchanger.
- ▶ Check and clean the secondary heat exchanger surfaces.

NOTE: Do not use wire brushes and cleaning agents to clean the stainless steel secondary heat exchanger components.

- ▶ Check the condensate route (C) is clear.
- ▶ The condensate trap (D) should be removed and checked for debris.
- ▶ Release the pipe locking tab (E) and disconnect the flexible pipe (F) from the top of the trap and move the flexible pipe up away from the trap
- ▶ Release the trap locking tab (G) and move the trap up and back to remove from its mountings.
- ▶ Clean the trap by flushing with water.
- ▶ Check the O ring seals and replace if necessary, grease the seals with a solvent free grease.
- ▶ Refit the trap making sure that the locking tabs are locked in place.
- ▶ Pour 500ml of water into drain (C) to refill the condensate trap.
- ▶ Clean the secondary heat exchanger baffles (I) if necessary and refit correctly.
- ▶ Refit the baffle retainer (H).
- ▶ Check the seal on the manifold access cover (K) and replace if necessary.
- ▶ Refit the flue manifold access cover (B) and secure with screws (A).

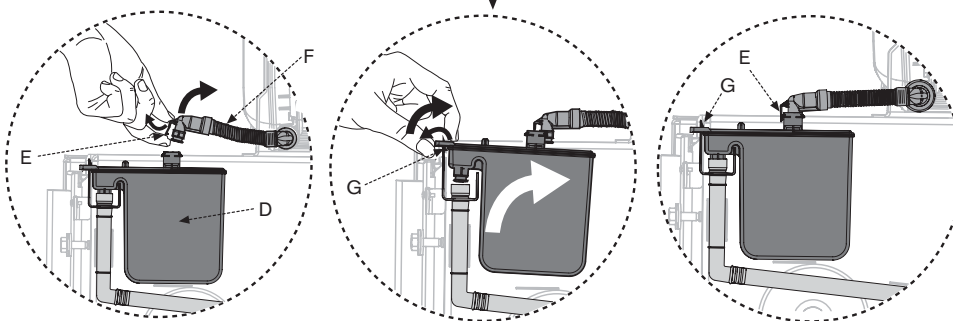
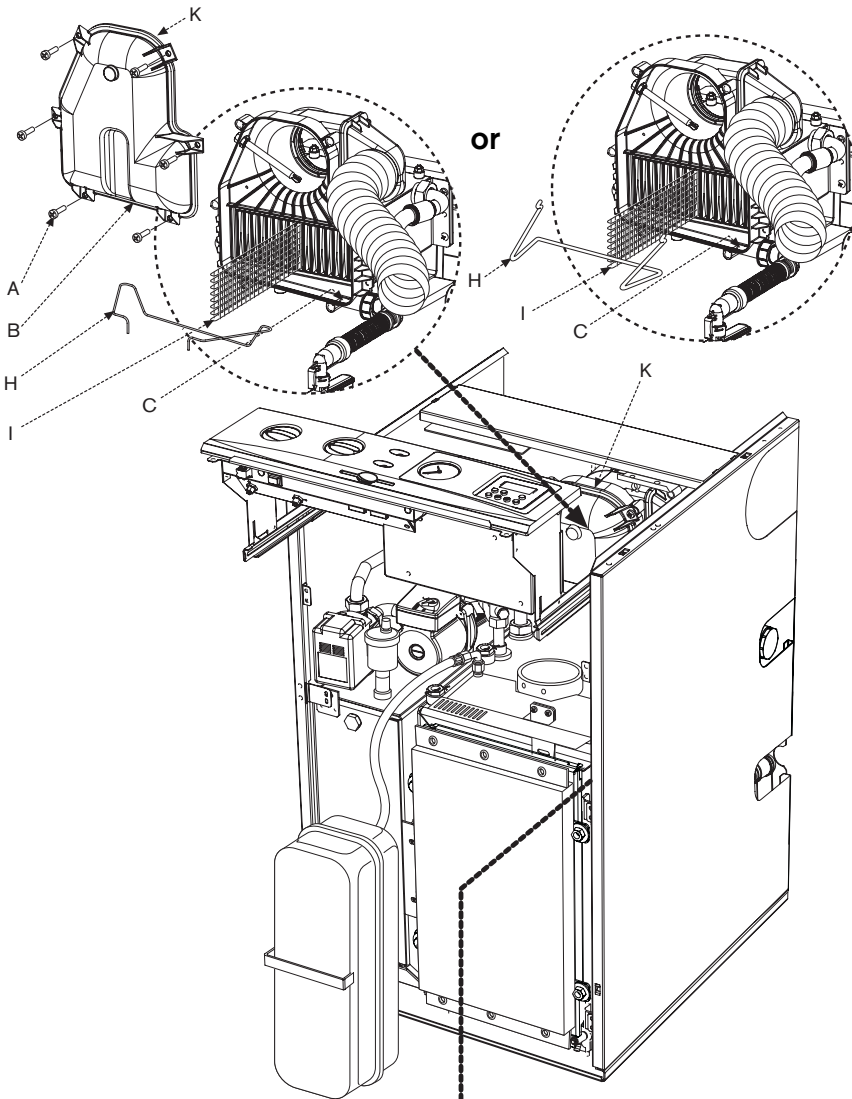

Combustion chamber:

- ▶ Release the M10 retaining nuts and washers (B) and remove combustion chamber access door (A).
- ▶ Check the fibreglass rope seal on the combustion chamber access door (A) and replace if necessary.
- ▶ Remove and check the baffle retainer (D).
- ▶ Remove the baffles (C), clean and check the condition of the baffles and the acoustic insulation. Replace any baffles or insulation pads considered to be badly corroded/degraded.
- ▶ Thoroughly clean all of the heat exchanger surfaces using a suitable brush and clear all loose debris from the combustion chamber.
- ▶ Check the condition of the combustion chamber access door insulation. If the insulation is damaged the door assembly must be replaced.
- ▶ Refit the items in reverse order ensure the baffles (C) and baffle retainers (D) are correctly fitted for the boiler output as shown in the plan view opposite.
- ▶ Refit combustion chamber door (A).

IMPORTANT: Secure with nuts and washers (B) and tighten, using the sequence shown in figure, until the chamber door is firmly secured, do not over tighten the nuts.

Fire valve:

- ▶ Check that the oil supply pipe has a fire valve fitted externally to the building with the fire valve sensor located within the appliance case. A fire valve sensor clip (E) is provided for this purpose.

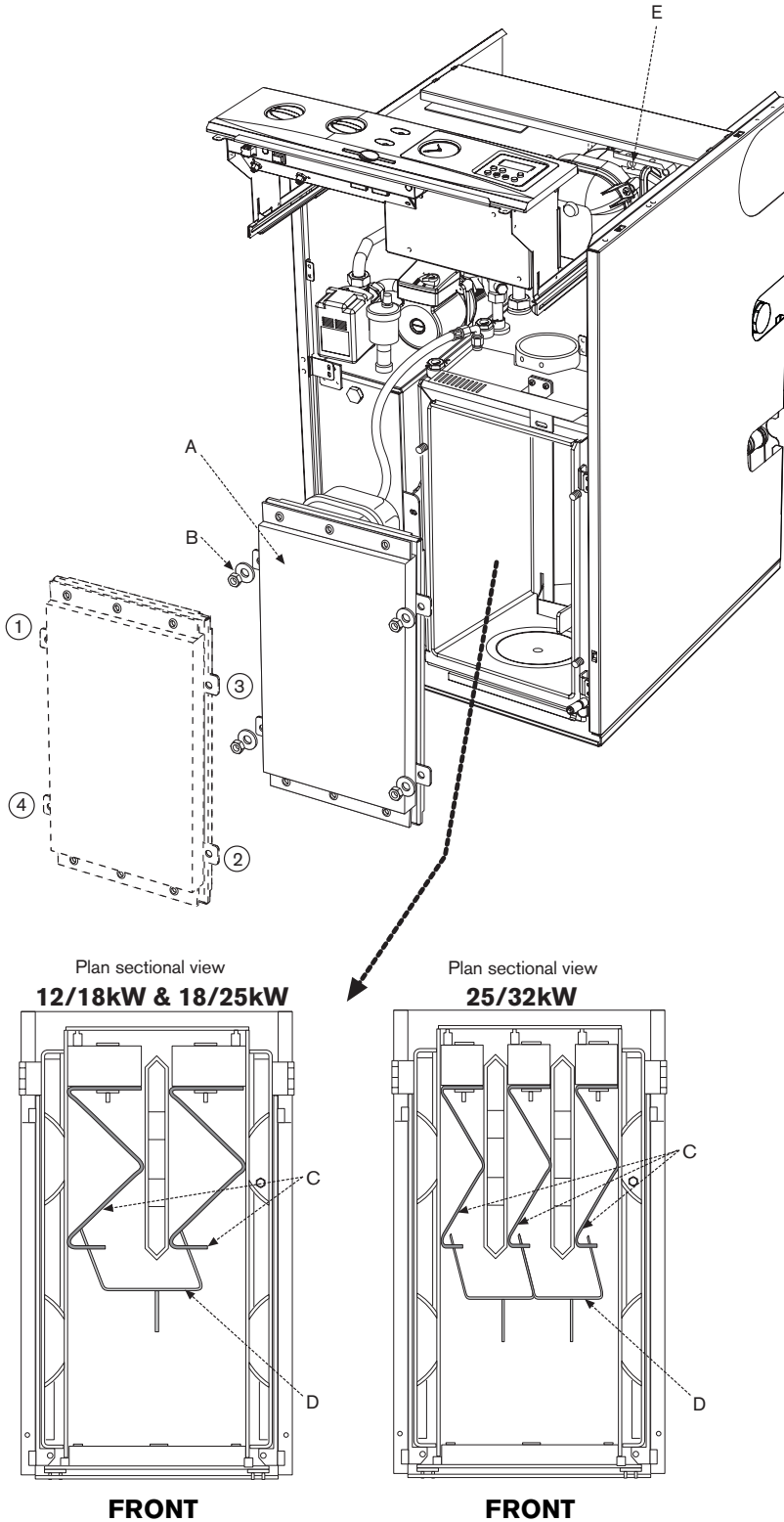

SERVICING & SPARES

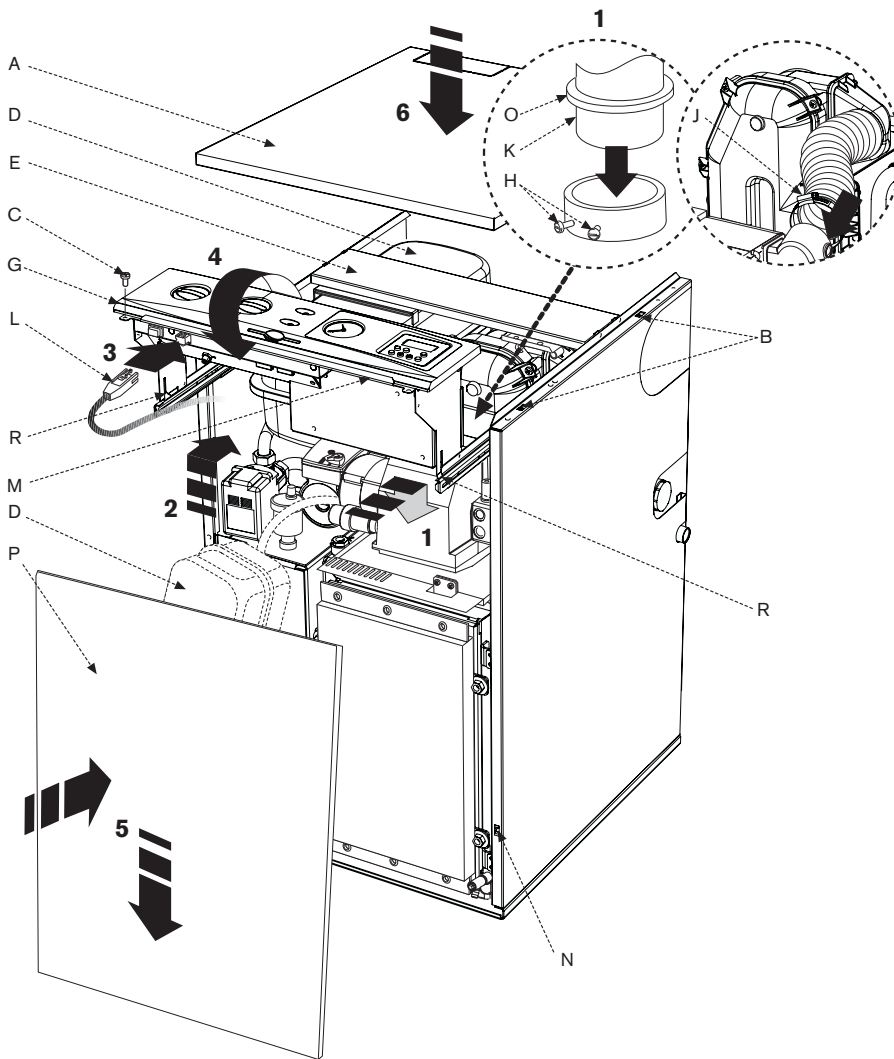

Re-commission the burner:

- 1 ▶ Align burner combustion head (K) into the boiler housing tube with gasket (O) correctly fitted.
 - ▶ Push firmly down to compress the gasket (O).
 - ▶ Tighten burner retainers (H) sufficiently to ensure a good seal.

IMPORTANT:

Ensure the gasket is a good seal between the burner combustion head and the boiler housing to prevent flue gases escaping from the combustion chamber into the room.

- ▶ Refit flexible air duct and secure with clip (J).
 - 2 ▶ Refit the expansion vessel (D) onto the support bracket (E) and taking care not to kink the flexible hose or snag the thermostat capillaries.
 - 3 ▶ Plug burner lead (L) into control box (G).
 - ▶ Connect an oil pressure gauge to the oil pump, run the burner and check the oil pressure is correct for the required boiler output. Check that the smoke reading is between 0 and 1, if the smoke reading is above 1 check the air setting. If the air setting is correct check that the burner has been reassembled correctly.
- Allow the boiler to warm up then check the combustion settings are correct as indicated in the table below, adjust the CO₂ if necessary using the air shutter.
- When the combustion is correct turn off the boiler, remove the pressure gauge and refit the blanking plug and plastic cover.

Refit panels:

- 4 ▶ Unlock supports (R) to pivot control box (G) and slide into the boiler.
 - ▶ Secure with screws (C).
- 5 ▶ Locate top edge of panel (P) onto the top supporting ledge (M) on the boiler.
 - ▶ Locate the ball stud connections (N) at the base of the front panel (P) and push towards the boiler to secure.
- 6 ▶ Locate the top panel (A) onto the ball stud connections (B) and press down to secure.

After service handover:

- ▶ Make a note of the date of any water treatment.
- ▶ Set the controls back to the users requirements.
- ▶ Complete the service interval record at the back of this manual and a CD11 or an equivalent form.
- ▶ If the appliance is unused and exposed to freezing conditions; shut off all the mains supplies, isolate the boiler and drain the system and boiler, including the secondary heat exchanger.

NOMINAL BOILER RATING AT NORMAL OPERATING TEMPERATURE USING 28sec KEROSENE:

NOZZLE	OIL PUMP PRESSURE (p.s.i.)	FUEL FLOW RATE		APPROX FLUE GAS TEMP. (°C)	%CO ₂	APPROX. AIR SETTING	AIR DAMPER DISC	APPLIANCE			
		Kg/h	l/h					INPUT		OUTPUT	
								kW	Btu/hr	kW	Btu/hr
12/18 - Bentone Sterling 40 Burner:											
0.35 80°SR	115	1.04	1.32	66	11.5	2.5	N/A	12.4	42300	12	40900
0.45 80°S	115	1.29	1.63	70	12.0	4.5	N/A	15.5	52900	15	51200
0.50 80°ES	140	1.55	1.96	73	12.5	5.25	N/A	18.6	63500	18	61400
18/25 - Bentone Sterling 50 Burner:											
0.50 80°EH	130	1.56	1.98	72	11.5	4.25	N/A	18.6	63300	18	61400
0.55 80°EH	145	1.86	2.36	79	12.0	6.0	N/A	22.2	75100	21.5	73400
0.65 80°EH	150	2.17	2.75	82	12.5	8.0	N/A	25.8	87900	25	85300
12/18 - Riello RDB 1 Burner											
0.35 80°SR	105	1.04	1.32	64	12.0	4.5	12kW	12.4	42300	12	40900
0.45 60°ES	120	1.29	1.63	67	12.0	3.0	15-18kW	15.5	52900	15	51200
0.50 60°ES	125	1.55	1.96	72	12.5	4.5	15-18kW	18.6	63500	18	61400
18/25 - Riello RDB 2.2 Burner											
0.50 60°ES	125	1.56	1.98	75	11.5	2.0	18-25kW	18.6	63300	18	61400
0.65 60°ES	120	1.86	2.36	78	12.0	3.0	18-25kW	22.2	75100	21.5	73400
0.75 60°ES	115	2.17	2.75	84	12.5	4.5	18-25kW	25.8	87900	25	85300
25/32 - Riello RDB 2.2 Burner											
0.75 60°ES	105	2.15	2.72	78	11.5	3.0	N/A	25.5	87040	25	85300
0.75 60°ES	140	2.45	3.10	80	12.0	4.0	N/A	29.1	99200	28.5	97200
0.85 60°ES	150	2.75	3.48	83	12.5	5.0	N/A	32.7	111400	32	109200

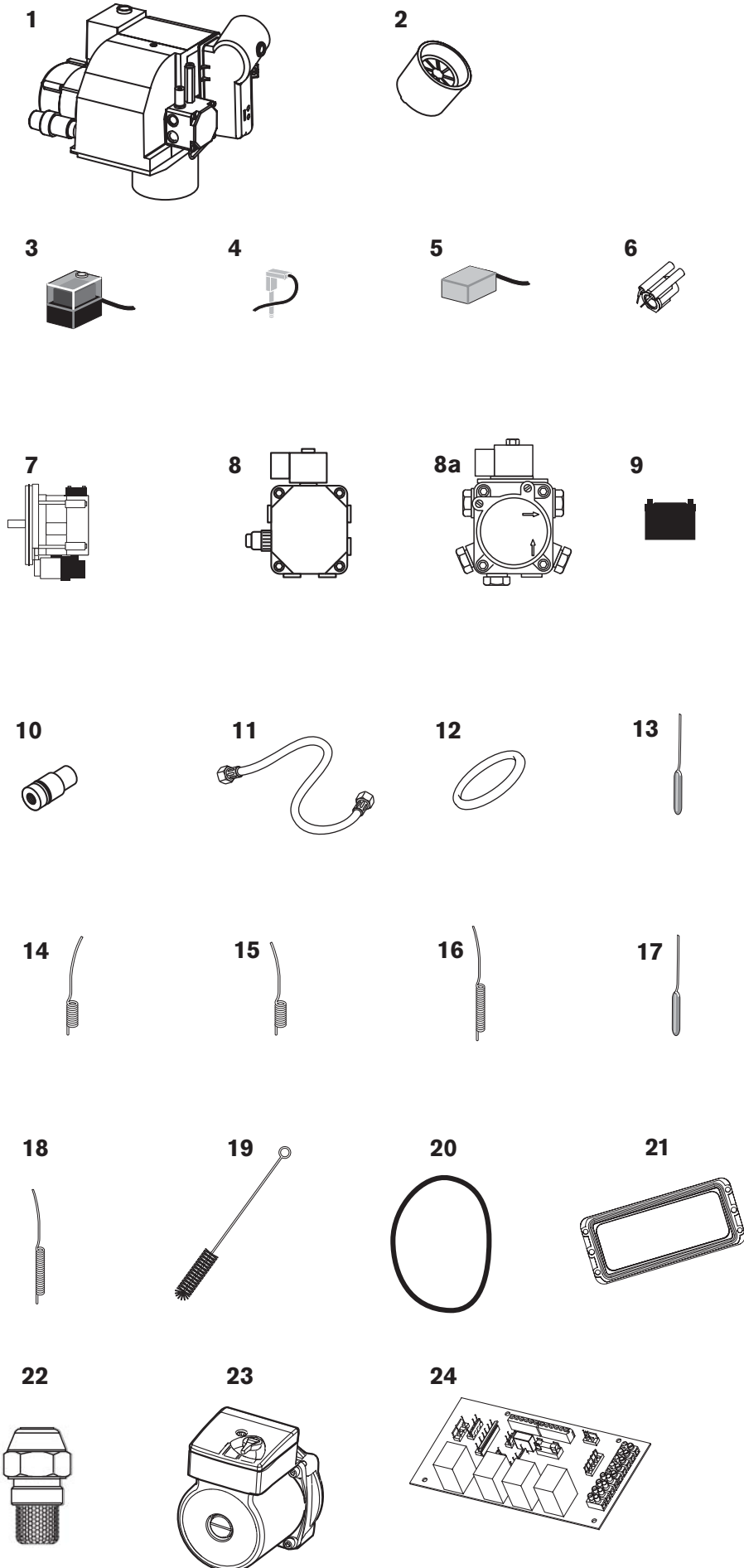

- 1 Burner - Sterling 40**
Part Number: 8 716 112 507 0
- 2 Combustion head - burner**
Part Number: 8 716 112 604 0
- 3 Control box Satronic DKO 970**
Part Number: 8 716 142 396 0
- 4 Photocell Satronic MZ770s**
Part Number: 8 716 156 692 0
- 5 Control box base Satronic S98 12 pole**
Part Number: 8 716 157 042 0
- 6 Ignition electrode**
Part Number: 8 716 142 752 0
- 7 Motor**
Part Number: 8 716 156 645 0
- 8 Oil pump - Danfoss BFP 11 L3**
Part Number: 8 716 142 736 0
- 8a Oil pump - Suntec AS47C**
Part Number: 8 716 157 014 0
- 9 Transformer (Excludes cable)**
Part Number: 8 716 156 696 0
- 10 Mechanical shut-off valve**
Part Number: 8 716 156 658 0
- 11 Flexible oil hose kit**
Part Number: 8 716 115 312 0
- 12 Burner 'O' ring gasket**
Part Number: 8 716 140 902 0
- 13 Heating control thermostat**
Part Number: 8 716 107 621 0
- 14 Auto reset High Limit thermostat**
Part Number: 8 716 107 640 0
- 15 Manual reset High Limit thermostat**
Part Number: 8 716 107 625 0
- 16 Manual reset flue thermostat**
Part Number: 8 716 107 624 0
- 17 DHW control thermostat**
Part Number: 8 718 685 283 0
- 18 Manual reset tank thermostat**
Part Number: 8 718 685 269 0
- 19 Cleaning brush**
Part Number: 8 716 109 428 0
- 20 Manifold access cover seal**
Part Number: 8 716 107 536 0
- 21 Secondary Heat Exchanger gasket**
Part Number: 8 716 112 954 0
- 22 Oil nozzle**
0.35 80° SR (12kW output)
Part Number: 8 716 112 628 0

0.45 80° S (15kW output)
Part Number: 8 716 106 197 0

0.50 80° ES (18kW output)
Part Number: 8 716 156 669 0
- 23 Circulation pump UPS 15-60**
Part Number: 8 718 685 525 0
- 24 Control board**
Part Number: 8 718 685 261 0

SERVICING & SPARES

BENTONE Sterling 50 burner

SHORT PARTS LIST 18/25

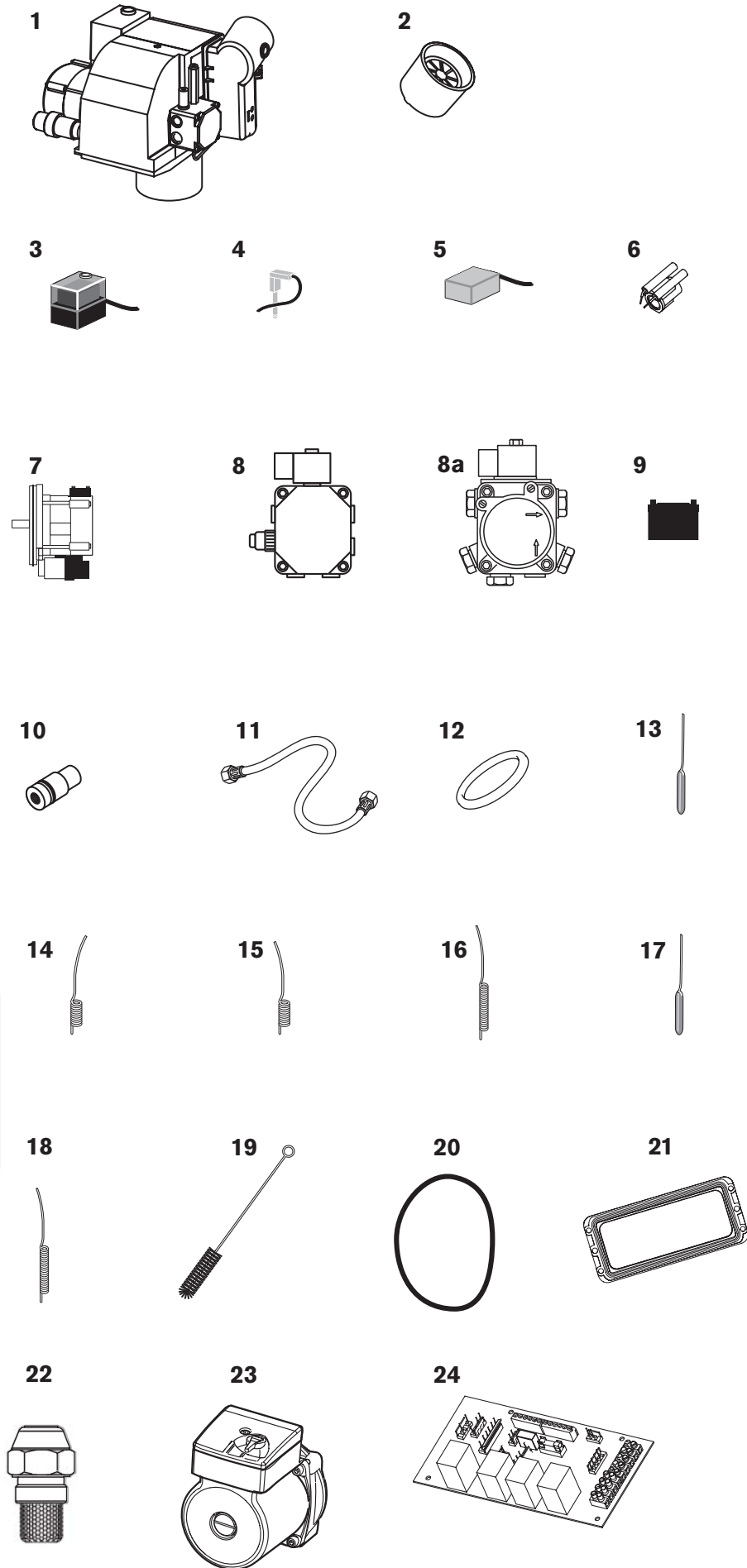

1 Burner - Sterling 50

Part Number: 8 716 108 570 0

2 Combustion head - burner

Part Number: 8 716 108 573 0

3 Control box Satronic DKO 970

Part Number: 8 716 142 396 0

4 Photocell Satronic MZ770s

Part Number: 8 716 156 692 0

5 Control box base Satronic S98 12 pole

Part Number: 8 716 157 042 0

6 Ignition electrode

Part Number: 8 716 142 752 0

7 Motor

Part Number: 8 716 156 645 0

8 Oil pump - Danfoss BFP 11 L3

Part Number: 8 716 142 736 0

8a Oil pump - Suntec AS47C

Part Number: 8 716 157 014 0

9 Transformer (Excludes cable)

Part Number: 8 716 156 696 0

10 Mechanical shut-off valve

Part Number: 8 716 156 658 0

11 Flexible oil hose kit

Part Number: 8 716 115 312 0

12 Burner 'O' ring gasket

Part Number: 8 716 140 902 0

13 Heating control thermostat

Part Number: 8 716 107 621 0

14 Auto reset High Limit thermostat

Part Number: 8 716 107 640 0

15 Manual reset High Limit thermostat

Part Number: 8 716 107 625 0

16 Manual reset flue thermostat

Part Number: 8 716 107 624 0

17 DHW control thermostat

Part Number: 8 718 685 283 0

18 Manual reset tank thermostat

Part Number: 8 718 685 269 0

19 Cleaning brush

Part Number: 8 716 109 428 0

20 Manifold access cover seal

Part Number: 8 716 107 536 0

21 Secondary Heat Exchanger gasket

Part Number: 8 716 112 954 0

22 Oil nozzle

0.50 80° EH (18kW output)

Part Number: 8 716 156 672 0

0.55 80° EH (21.5kW output)

Part Number: 8 716 156 671 0

0.65 80° EH (25kW output)

Part Number: 8 716 110 362 0

23 Circulation pump UPS 15-60

Part Number: 8 718 685 525 0

24 Control board

Part Number: 8 718 685 261 0

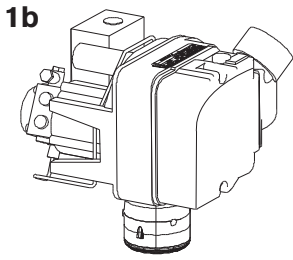

2

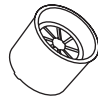

3

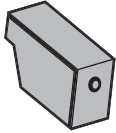

4

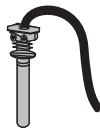

5



6

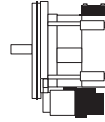

7

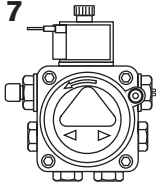

8



9



10



11



12



13



14



15



16



17

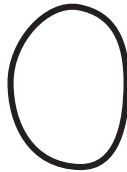

18

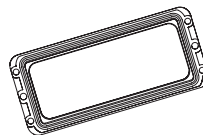

19



20

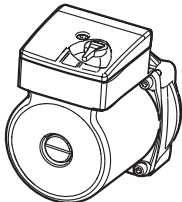

21

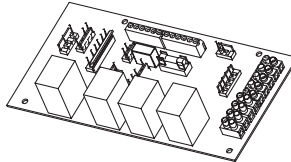

1 Burner - Riello RDB 1 12/18

Part Number: 8 718 685 873 0

2 Combustion head - LD2SX (Short)

Part Number: 8 718 685 902 0

3 Control box MO535

Part Number: 8 718 682 250 0

4 Photocell

Part Number: 8 716 109 193 0

5 Ignition electrode

Part Number: 8 716 109 183 0

6 Motor

Part Number: 8 716 109 186 0

7 Oil pump - Riello RDB

Part Number: 8 716 115 297 0

8 Flexible oil hose kit

Part Number: 8 716 115 312 0

9 Burner 'O' ring gasket

Part Number: 8 718 682 439 0

10 Heating control thermostat

Part Number: 8 716 107 621 0

11 Auto reset High Limit thermostat

Part Number: 8 716 107 640 0

12 Manual reset High Limit thermostat

Part Number: 8 716 107 625 0

13 Manual reset flue thermostat

Part Number: 8 716 107 624 0

14 DHW control thermostat

Part Number: 8 716 107 637 0

15 Manual reset tank thermostat

Part Number: 8 718 685 269 0

16 Cleaning brush

Part Number: 8 716 109 428 0

17 Manifold access cover seal

Part Number: 8 716 107 536 0

18 Secondary Heat Exchanger gasket

Part Number: 8 716 112 954 0

19 Oil nozzle

0.35 80° SR (12kW output)

Part Number: 8 716 112 628 0

0.45 60° ES (15kW output)

Part Number: 8 716 156 679 0

0.5 60° ES (18kW output)

Part Number: 8 716 156 671 0

20 Circulation pump UPS 15-60

Part Number: 8 718 685 525 0

21 Control board

Part Number: 8 718 685 261 0

SERVICING & SPARES

SHORT PARTS LIST 18/25

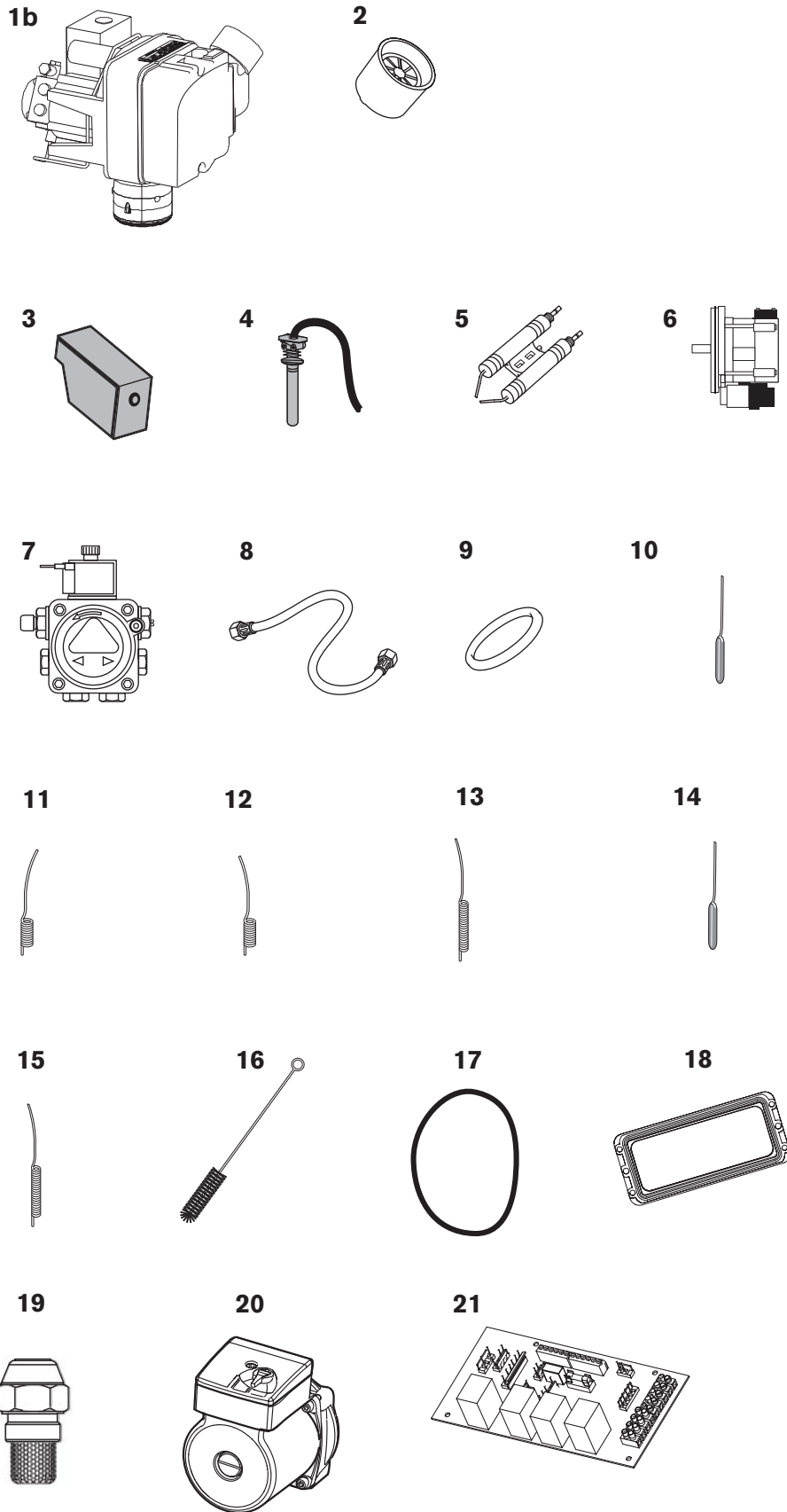

- 1 Burner - Riello RDB 2.2 18/25**
Part Number: 8 718 685 836 0
- 2 Combustion head - LD2SX (Short)**
Part Number: 8 718 685 872 0
- 3 Control box MO535**
Part Number: 8 718 682 250 0
- 4 Photocell**
Part Number: 8 716 109 193 0
- 5 Ignition electrode**
Part Number: 8 716 109 183 0
- 6 Motor**
Part Number: 8 716 109 186 0
- 7 Oil pump - Riello RDB**
Part Number: 8 716 115 297 0
- 8 Flexible oil hose kit**
Part Number: 8 716 115 312 0
- 9 Burner 'O' ring gasket**
Part Number: 8 718 682 439 0
- 10 Heating control thermostat**
Part Number: 8 716 107 621 0
- 11 Auto reset High Limit thermostat**
Part Number: 8 716 107 640 0
- 12 Manual reset High Limit thermostat**
Part Number: 8 716 107 625 0
- 13 Manual reset flue thermostat**
Part Number: 8 716 107 624 0
- 14 DHW control thermostat**
Part Number: 8 716 107 637 0
- 15 Manual reset tank thermostat**
Part Number: 8 718 685 269 0
- 16 Cleaning brush**
Part Number: 8 716 109 428 0
- 17 Manifold access cover seal**
Part Number: 8 716 107 536 0
- 18 Secondary Heat Exchanger gasket**
Part Number: 8 716 112 954 0
- 19 Oil nozzle**
0.5 60° ES (18kW output)
Part Number: 8 716 156 671 0
0.65 60° ES (21.5kW output)
Part Number: 8 716 115 843 0
0.75 60° ES (25kW output)
Part Number: 8 716 106 156 0
- 20 Circulation pump UPS 15-60**
Part Number: 8 718 685 525 0
- 21 Control board**
Part Number: 8 718 685 261 0

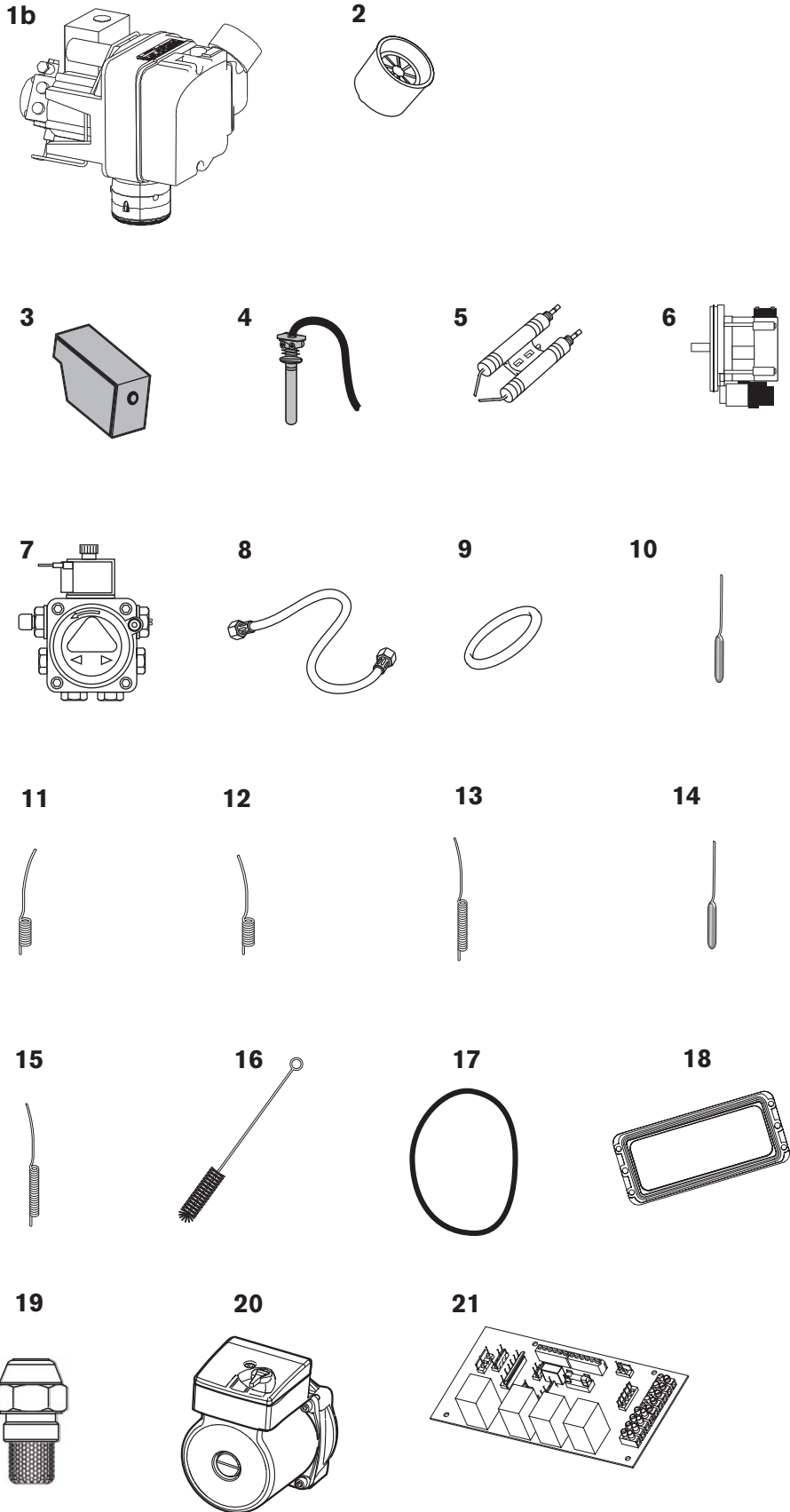

1 Burner - Riello RDB 2.2 25/32 HE

Part Number: 8 716 112 512 0

2 Combustion head - burner

Part Number: 8 716 112 521 0

3 Control box MO535

Part Number: 8 718 682 250 0

4 Photocell

Part Number: 8 716 109 193 0

5 Ignition electrode

Part Number: 8 716 109 183 0

6 Motor

Part Number: 8 716 109 186 0

7 Oil pump - Riello RDB

Part Number: 8 716 115 297 0

8 Flexible oil hose kit

Part Number: 8 716 115 312 0

9 Burner 'O' ring gasket

Part Number: 8 718 682 439 0

10 Heating control thermostat

Part Number: 8 716 107 621 0

11 Auto reset High Limit thermostat

Part Number: 8-716-107-640-0

12 Manual reset High Limit thermostat

Part Number: 8 716 107 625 0

13 Manual reset flue thermostat

Part Number: 8 716 107 624 0

14 DHW control thermostat

Part Number: 8 718 685 283 0

15 Manual reset tank thermostat

Part Number: 8 718 685 269 0

16 Cleaning brush

Part Number: 8 716 109 428 0

17 Manifold access cover seal

Part Number: 8 716 107 536 0

18 Secondary Heat Exchanger gasket

Part Number: 8 716 112 954 0

19 Oil nozzle

0.75 60° ES (25 & 28.5kW output)

Part Number: 8 716 106 156 0

0.85 60° ES (32kW output)

Part Number: 8 716 110 083 0

20 Circulation pump UPS 15-70

Part Number: 8 718 685 526 0

21 Control board

Part Number: 8 718 685 261 0

SERVICING & SPARES

PROBLEM	CAUSE	REMEDY
LOCKOUT:		
Pulsation on start	CF - Flue draught incorrect Combustion settings incorrect Faulty nozzle	CF - Check flue draught Set up as in installation instructions Replace nozzle
Intermittent lockout	Bad electrical connection Intermittent flame detection fault Down draught	Check control box/electrical connections See flame detection fault Extend flue or fit an anti-downdraught cowl (CF only)
Burner motor fails to operate	Faulty motor or electrical supply to motor Control box fault	Check for 230V to motor during startup period Replace control box
Flame detection fault	Photocell filmed over (dirty) Photocell faulty Control box faulty	Wipe clean Replace Replace
Incorrect CO ₂	Air adjustment fault Oil pressure incorrect	Set up as in installation instructions Set up as in installation instructions
No oil from nozzle	No oil at pump Air in pump Nozzle blocked Faulty pump or drive Faulty mechanical shut off valve (12/18 & 18/25 only)	Check and refill oil tank/bleed oil line Check and clean filters & valves from oil tank to boiler Bleed pump Replace nozzle Replace Clean or replace
Ignition failure	Electrode settings incorrect Faulty ignition transformer Open circuit ignition Faulty control box or electrical connections not properly made	Set up as in installation instructions Replace Check and replace electrodes or high tension leads if necessary Correct electrical control box connections or replace control box
BURNER FAILS TO START:	No power to boiler Faulty boiler thermostat Programmer open circuit Faulty control box	Check electrical / control circuit Check by temporarily linking out high limit and control thermostats Check by temporarily linking 8 & 9 on the connector Replace
HIGH SMOKE NUMBER:	Air intake/flue blocked Incorrect combustion settings Oil pressure incorrect Incorrect components used on combustion head Faulty nozzle	Check & clear air intake/flue Set up as in installation instructions Adjust to correct pressure Check with installation instructions Replace nozzle

FAULT FINDING

BOILER LOCKOUT :

Indicated by the illumination of the 'Lockout' indicator on the fascia.
To reset, wait 2 minutes then press the lockout reset button.

Also refer to fault finding logic on pages 51 and 52

FAULT FINDING & DIAGRAMS

UNDER NO CIRCUMSTANCES MUST AN APPLIANCE BE LEFT TO OPERATE WITH ANY CONTROL LINKED OUT OR OVERRIDDEN.

PROBLEM	CAUSE	REMEDY	FAULT FINDING
FAULTY BOILER OPERATION:			
Noisy operation	Pump noise from air in pump or worn pump Worn motor bearings Fan out of balance	Bleed air from pump or replace pump Replace motor Replace fan	
Boiling	Faulty boiler thermostat Short circuit boiler thermostat Thermostat bulb not fully home in pocket No primary water circulation	Replace if necessary Temporarily take out of circuit to check Ensure bulb is pushed fully home Check system / circulating pump/ tank overheat thermostat	
Short Cycling	Burner rating incorrect Boiler thermostat differential incorrect External controls not operating correctly	Correct burner rating Replace boiler thermostat Check and correct external controls	
OIL SMELLS:			
	Blocked flue, fumes on startup Oil soaked boiler, faulty burner operation, numerous lockouts Odour in boiler room, oil leaks from pipework, flexible hoses connections	CF - Check flue with gauge and check seals/gaskets RS - Check seals/gaskets Rectify burner operation and lockouts Rectify oil leaks, replace components if necessary	

This operation instruction is provided to assist competent and suitably qualified engineers to locate and rectify faults. Whilst every effort has been taken to ensure the information given is correct and complete we cannot guarantee that every eventuality has been covered. Worcester, Bosch Group cannot be held responsible for costs incurred by persons not deemed to be competent.

STATUS	CODE	ADDITIONAL INFORMATION
Operational Codes		
OFF	OFF	
Initial check time (11 seconds) before pre-purge	OFF	
Pre-purge (15 seconds)	ORANGE Flashing	
Safety time (maximum 5 seconds)	GREEN Flashing	Only when the solenoid valve is energised with no flame signal.
Running	GREEN	
Lock-out/Error Codes		
False light before ignition	GREEN, RED	
Under voltage or over voltage	RED, ORANGE	
lock-out for no flame during safety time	RED	
Lock-out for false flame signal / Lock-out for burner control error	RED Flashing	
Lock-out for maximum number of restarts	RED Fast flashing	
Pump Priming Cycle		
Pump priming cycle	GREEN, ORANGE, RED	In the lock-out condition, the oil pump can be primed for 30 seconds: 1. Press the remote reset button for more than 6 seconds and then release. The control box lock-out reset will blink quickly green, orange and red. 2. Re-press the burner reset button and release within 3 seconds and pump priming starts.

Lock-out and Reset

The control box can be reset consecutively a maximum number of 5 times after which the power supply has to be reset; then the control box can be reset a further 5 times.

Limit of Restarts

If the flame is lost during operation; the burner will restart 3 times. On the 4th restart the burner will go to lock-out. By resetting the power supply the control box is reset and allows 3 restarts.

Flame Detection

Flame detection minimum current:	30µA
Flame loss maximum current:	25µA
False flame maximum current (without false light):	19µA

FAULT FINDING & DIAGRAMS

These fault finding charts are provided to assist competent and suitably qualified engineers to locate and rectify faults. Whilst every effort has been taken to ensure the information given is correct and complete we cannot guarantee that every eventuality has been covered. Worcester, Bosch Group cannot be held responsible for costs incurred by persons not deemed to be competent.

FAULT FINDING LOGIC FOR SATRONIC CONTROL BOX

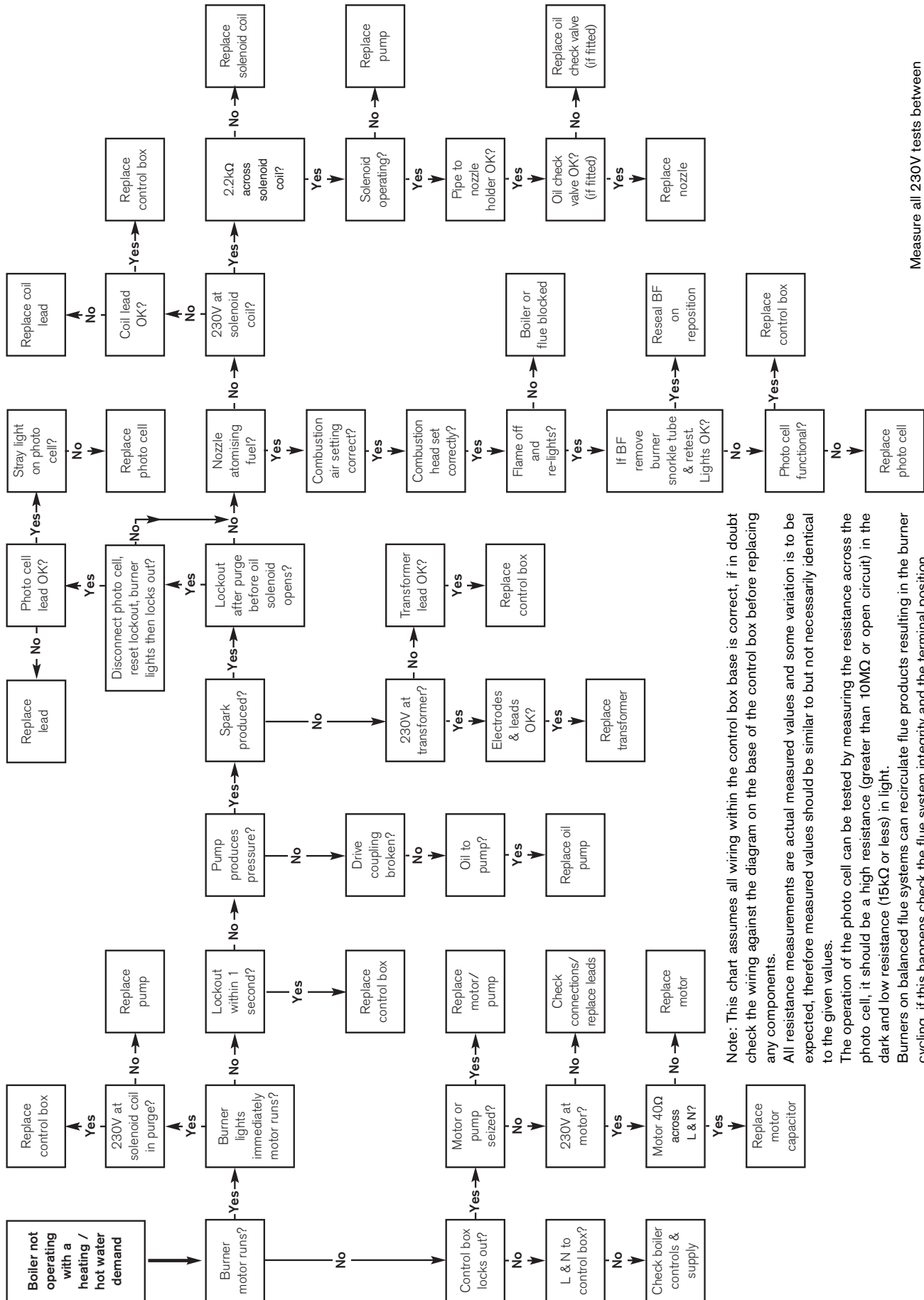

Measure all 230V tests between Neutral (N) and the pin, wire or terminal specified.

Note: This chart assumes all wiring within the control box base is correct, if in doubt check the wiring against the diagram on the base of the control box before replacing any components.
 All resistance measurements are actual measured values and some variation is to be expected, therefore measured values should be similar to but not necessarily identical to the given values.
 The operation of the photo cell can be tested by measuring the resistance across the photo cell, it should be a high resistance (greater than 10MΩ or open circuit) in the dark and low resistance (15kΩ or less) in light.
 Burners on balanced flue systems can recirculate flue products resulting in the burner cycling, if this happens check the flue system integrity and the terminal position.

These fault finding charts are provided to assist competent and suitably qualified engineers to locate and rectify faults. Whilst every effort has been taken to ensure the information given is correct and complete we cannot guarantee that every eventuality has been covered.

Worcester, Bosch Group cannot be held responsible for costs incurred by persons not deemed to be competent.

FAULT FINDING LOGIC FOR RIELLO CONTROL BOXES

MO535 IMPORTANT NOTE: The box has a built in delay of 11 seconds before activating the motor. The preheater link must be fitted at for the box to operate

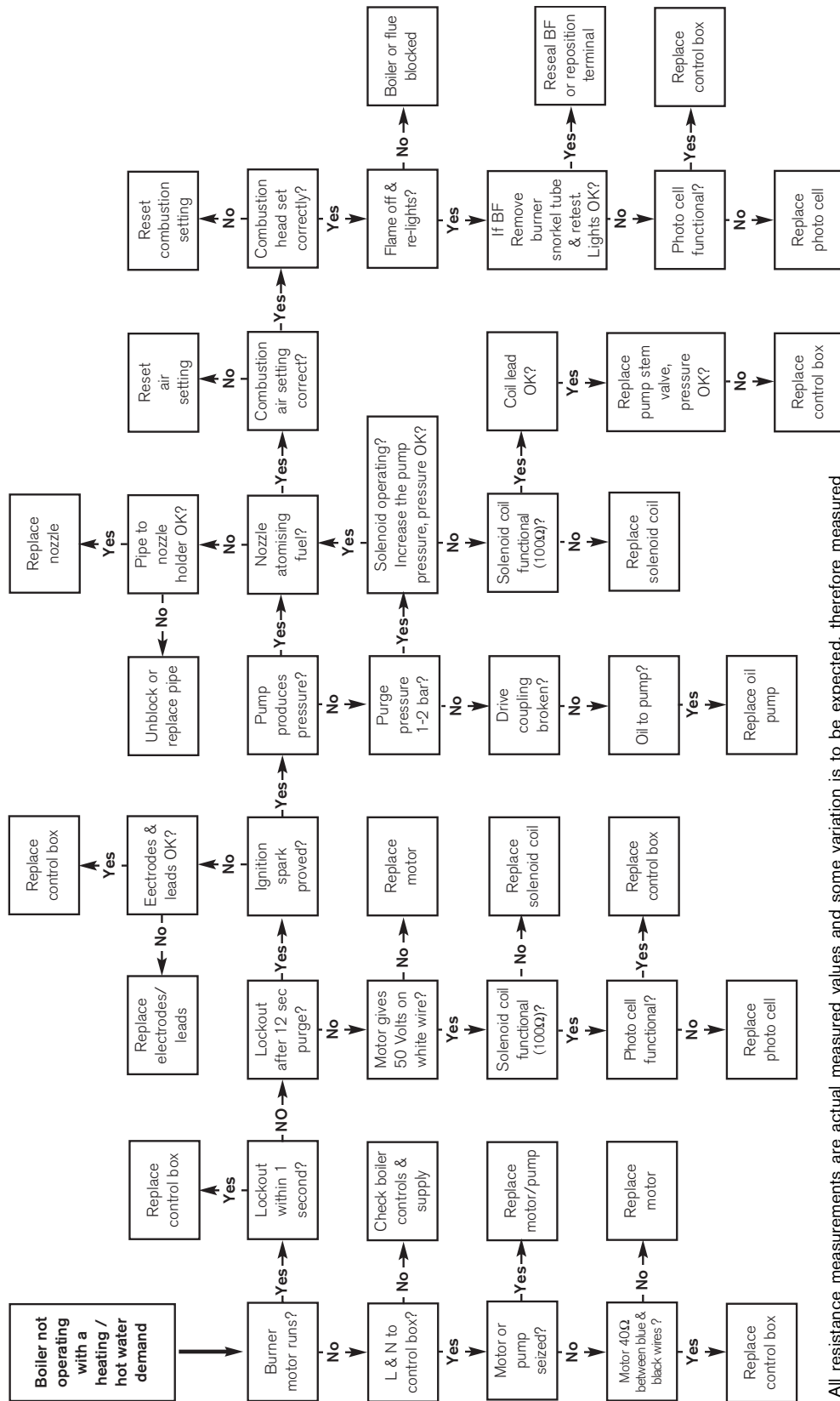

Measure all 230V tests between Neutral (N) and the pin, wire or terminal specified.

All resistance measurements are actual measured values and some variation is to be expected, therefore measured values should be similar to but not necessarily identical to the given values. The operation of the photo cell can be tested by measuring the resistance across the photo cell, it should be a high resistance (greater than 10MΩ or open circuit) in the dark and low resistance (3kΩ or less) in light. Burners on balanced flue systems can recirculate flue products resulting in the burner cycling, if this happens check the flue system integrity and the terminal position.

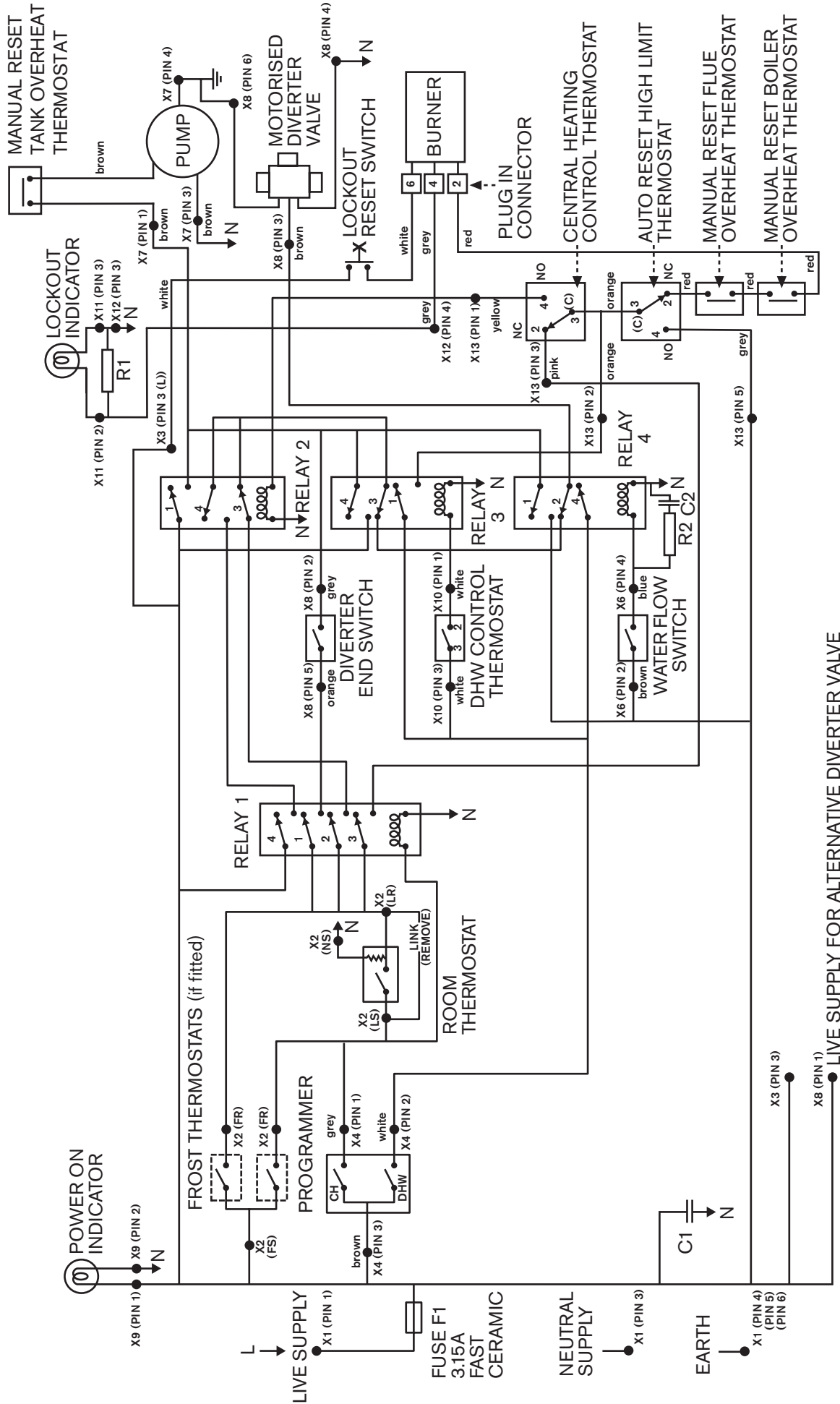

FAULT FINDING & DIAGRAMS

53

HEATSLAVE BOILER COMMISSIONING CHECKLIST

BOILER MODEL _____ **SERIAL No.** _____

COMMISSIONING ENGINEER

COMMISSIONING CHECKS

COMPANY NAME:	PUMP PRESSURE (PSI):
ADDRESS:	CO ₂ %:
ENGINEERS NAME:	SMOKE READING:
SIGNATURE:	F.G.T.°C:
DATE:	FLUE PRESSURE:
	BURNER MODEL:

CONTROLS *To comply with the Building Regulations, each section must have a tick in one or other of the boxes*

TIME & TEMPERATURE CONTROL TO HEATING	ROOM T/STAT & PROGRAMMER/TIMER <input type="checkbox"/>	PROGRAMMABLE ROOMSTAT <input type="checkbox"/>
TIME CONTROL TO HOT WATER	PROGRAMMER/TIMER <input type="checkbox"/>	
HEATING ZONE VALVES	FITTED <input type="checkbox"/>	NOT REQUIRED <input type="checkbox"/>
THERMOSTATIC RADIATOR VALVES	FITTED <input type="checkbox"/>	
AUTOMATIC BYPASS TO SYSTEM	FITTED <input type="checkbox"/>	NOT REQUIRED <input type="checkbox"/>

CONFIRM THE FOLLOWING:

THE CONDENSATE DRAIN HAS BEEN INSTALLED IN ACCORDANCE WITH THE INSTRUCTIONS	YES <input type="checkbox"/>
OIL TYPE USED IS KEROSENE	YES <input type="checkbox"/>
THE SYSTEM HAS BEEN FLUSHED IN ACCORDANCE WITH THE INSTRUCTIONS?	YES <input type="checkbox"/>
THE SYSTEM CLEANER USED:	
THE INHIBITOR USED:	
HAS A WATER SCALE REDUCER BEEN FITTED?	YES <input type="checkbox"/> NO <input type="checkbox"/>
WHAT TYPE OF SCALE REDUCER HAS BEEN FITTED?	

FOR THE DOMESTIC HOT WATER MODE, MEASURE & RECORD:

WATER FLOW RATE _____ lts/min

CONFIRM THE FOLLOWING:

THE HEATING AND HOT WATER SYSTEM COMPLIES WITH CURRENT BUILDING REGULATIONS	NO <input type="checkbox"/>	YES <input type="checkbox"/>	
THE APPLIANCE AND ASSOCIATED EQUIPMENT HAS BEEN INSTALLED AND COMMISSIONED IN ACCORDANCE WITH THE MANUFACTURER'S INSTRUCTIONS	NO <input type="checkbox"/>	YES <input type="checkbox"/>	
HAVE YOU RECORDED A CO/CO ₂ RATIO READING?	N/A <input type="checkbox"/>	YES <input type="checkbox"/>	CO/CO ₂ RATIO
THE OPERATION OF THE APPLIANCE AND SYSTEM CONTROLS HAVE BEEN DEMONSTRATED TO THE CUSTOMER	NO <input type="checkbox"/>	YES <input type="checkbox"/>	

IMPORTANT: LEAVE THIS MANUAL WITH THE HOMEOWNER

SERVICE INTERVAL RECORD

It is recommended that the heating system is serviced regularly and that you complete the appropriate Service Interval Record Overleaf.

Service Provider.

Before completing the appropriate Service Interval Record overleaf, please ensure you have carried out the service as described in this manual. Always use Worcester, Bosch Group specified spare parts.

SERVICE 1 DATE _____

ENGINEER NAME _____
 COMPANY NAME _____
 TEL No. _____
 OFTEC REG No. _____
 PUMP PRESSURE: psi | CO₂%: _____
 NOZZLE CHANGED? YES NO
 F.G.T. °C | FLUE PRESSURE: _____
 COMMENTS _____

 SIGNATURE _____

SERVICE 2 DATE _____

ENGINEER NAME _____
 COMPANY NAME _____
 TEL No. _____
 OFTEC REG No. _____
 PUMP PRESSURE: psi | CO₂%: _____
 NOZZLE CHANGED? YES NO
 F.G.T. °C | FLUE PRESSURE: _____
 COMMENTS _____

 SIGNATURE _____

SERVICE 3 DATE _____

ENGINEER NAME _____
 COMPANY NAME _____
 TEL No. _____
 OFTEC REG No. _____
 PUMP PRESSURE: psi | CO₂%: _____
 NOZZLE CHANGED? YES NO
 F.G.T. °C | FLUE PRESSURE: _____
 COMMENTS _____

 SIGNATURE _____

SERVICE 4 DATE _____

ENGINEER NAME _____
 COMPANY NAME _____
 TEL No. _____
 OFTEC REG No. _____
 PUMP PRESSURE: psi | CO₂%: _____
 NOZZLE CHANGED? YES NO
 F.G.T. °C | FLUE PRESSURE: _____
 COMMENTS _____

 SIGNATURE _____

SERVICE 5 DATE _____

ENGINEER NAME _____
 COMPANY NAME _____
 TEL No. _____
 OFTEC REG No. _____
 PUMP PRESSURE: psi | CO₂%: _____
 NOZZLE CHANGED? YES NO
 F.G.T. °C | FLUE PRESSURE: _____
 COMMENTS _____

 SIGNATURE _____

SERVICE 6 DATE _____

ENGINEER NAME _____
 COMPANY NAME _____
 TEL No. _____
 OFTEC REG No. _____
 PUMP PRESSURE: psi | CO₂%: _____
 NOZZLE CHANGED? YES NO
 F.G.T. °C | FLUE PRESSURE: _____
 COMMENTS _____

 SIGNATURE _____

SERVICE 7 DATE _____

ENGINEER NAME _____
 COMPANY NAME _____
 TEL No. _____
 OFTEC REG No. _____
 PUMP PRESSURE: psi | CO₂%: _____
 NOZZLE CHANGED? YES NO
 F.G.T. °C | FLUE PRESSURE: _____
 COMMENTS _____

 SIGNATURE _____

SERVICE 8 DATE _____

ENGINEER NAME _____
 COMPANY NAME _____
 TEL No. _____
 OFTEC REG No. _____
 PUMP PRESSURE: psi | CO₂%: _____
 NOZZLE CHANGED? YES NO
 F.G.T. °C | FLUE PRESSURE: _____
 COMMENTS _____

 SIGNATURE _____

SERVICE 9 DATE _____

ENGINEER NAME _____
 COMPANY NAME _____
 TEL No. _____
 OFTEC REG No. _____
 PUMP PRESSURE: psi | CO₂%: _____
 NOZZLE CHANGED? YES NO
 F.G.T. °C | FLUE PRESSURE: _____
 COMMENTS _____

 SIGNATURE _____

SERVICE 10 DATE _____

ENGINEER NAME _____
 COMPANY NAME _____
 TEL No. _____
 OFTEC REG No. _____
 PUMP PRESSURE: psi | CO₂%: _____
 NOZZLE CHANGED? YES NO
 F.G.T. °C | FLUE PRESSURE: _____
 COMMENTS _____

 SIGNATURE _____

If the boiler does not give complete satisfaction, before calling for a service engineer, the installer should check the following:

General checks

1. Is there 230V across the boiler live and neutral terminals?
2. Is the polarity correct? (230V across live and earth, 0V across neutral and earth)
2. Is the air bled from the primary system?
3. Is the air bled from the oil supply?
4. Is the flue sized and routed correctly?

Boiler runs straight to lockout

1. Has the oil line been purged of air.
2. Where an air eliminator is used in conjunction with a top feed oil tank the non-return valve, (if fitted), should be removed from the oil dip pipe.

Boiler locks out at the start of a demand (Heating off overnight for example)

1. If an air eliminator is being used, check that there are no leaks that allow air to be pulled into the oil supply.
2. If a two pipe oil supply is being used, has a non-return valve been fitted to the inlet pipe? Refer to the instructions for guidelines.

No domestic hot water

1. Is the mains water in connected to the 15mm isolation valve?
2. Is there a domestic hot water demand from the programmer and has the tank reached temperature?

No domestic hot water (external programmer)

1. Is there 230V on pin 2 of terminal block X4?
2. Remove the external wiring from terminal block X4 and fit a link across 1 and 2, if the domestic hot water now operates there is a problem with the external programmer and/or its wiring.

No central heating

1. Are both programmer and room thermostat on demand for central heating?
2. Is the room thermostat wired correctly?
3. Refit the link across pins 2 and 3 on terminal X2, if the central heating now operates correctly the room thermostat and/or its wiring are faulty.

No central heating (external programmer)

1. Are both programmer and room thermostat on demand for central heating?
2. Is the room thermostat wired correctly?
3. Refit the link across pins 2 and 3 on terminal X2, if the central heating now operates correctly the room thermostat and/or its wiring are faulty.
4. Is there 230V on pin 1 of terminal block X4? If not remove the external wiring to terminal block X4 and fit a link across pins 1 and 3 on terminal X4, if the central heating now operates correctly the programmer and/or its wiring are faulty.

UNDER NO CIRCUMSTANCES MUST AN APPLIANCE BE LEFT TO OPERATE WITH ANY CONTROL LINKED OUT OR OVER RIDDEN.

CONTACT INFORMATION

WORCESTER, BOSCH GROUP:

TECHNICAL:	08705 266241
SERVICE:	08457 256206
SERVICE (EIRE):	01494 0099
SPARES:	01905 752571
LITERATURE:	01905 752556
TRAINING:	01905 752526
SALES:	01905 752640
WEBSITE:	worcester-bosch.co.uk
WEBSITE (EIRE):	worcester-bosch.ie

Dedicated to heating comfort

Worcester, Bosch Group

Cotswold Way, Warndon, Worcester WR4 9SW.

Tel. 01905 754624 Fax. 01905 754619

Worcester, Bosch Group is a brand name of Bosch Thermotechnology Ltd.

worcester-bosch.co.uk

8 716 106 252f (03/2010)

