



WORCESTER

Bosch Thermotechnik

Highflow 400 BF

FLOOR STANDING COMBINATION APPLIANCE FOR CENTRAL
HEATING AND MAINS FED DOMESTIC HOT WATER

INSTALLATION AND SERVICING INSTRUCTIONS

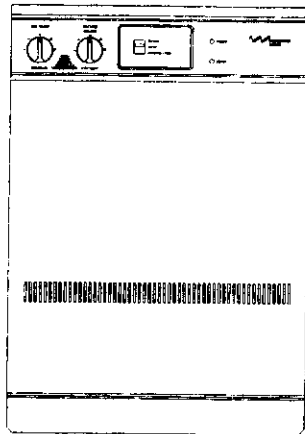

GC NUMBER 47 311 19

APPLIES TO
APPLIANCES
PRE MAY 1997

BOILER OUTPUT

To Hot Water On/Off Control
Maximum 24.0 kW (82,000 Btu/h)

To Central Heating On/Off Control. Range Rated
Minimum 8.8 kW (30,000 Btu/h)
Maximum 24.0 kW (82,000 Btu/h)

IMPORTANT: THIS APPLIANCE IS FOR USE WITH NATURAL GAS ONLY

THESE INSTRUCTIONS APPLY IN THE UK ONLY

THESE INSTRUCTIONS ARE TO BE LEFT WITH THE USER OR AT THE GAS METER

**This appliance must be installed by a competent person in accordance
with the Gas Safety (Installation and Use) Regulations 1994**

Contents

1. Installation Requirements	Page 2
2. General Information	Page 2
3. Technical Data	Page 5
4. Siting the Appliance	Page 6
5. Flue Terminal Position	Page 8
6. Air Supply	Page 8
7. Sealed System	Page 9
8. Open Vent System	Page 10
9. Hot Water Supply	Page 10
<hr/>	
10. Electrical	Page 11
11. Installing the Appliance	Page 13
12. Commissioning the Appliance	Page 18
13. Instructions to the User	Page 20
14. Inspection and Service	Page 20
15. Replacement of Parts	Page 21
16. Operational Flow Diagrams	Page 36
17. Fault Finding	Page 38
18. Component Parts List	Page 44

1. Installation Requirements

1.1 Gas Safety (Installation and Use) Regulations 1994: All gas appliances must be installed by a competent person in accordance with the above regulations. Failure to install appliances correctly could lead to prosecution.

1.2 The manufacturers notes must not be taken, in any way, as overriding statutory obligations.

1.3 The compliance with a British Standard does not, of itself, confer immunity from legal obligations. In particular the installation of this appliance must be in accordance with the relevant requirements of the following: Gas Safety (Installation and Use) Regulations 1984 (as amended), current IEE Wiring Regulations, local Building Regulations, Building Standards (Scotland) (Consolidation), byelaws of the local Water Company and Health and Safety Document No. 635 (Electricity at Work Regulations 1989). The British Gas Material and Installation Specification for central heating and hot water. It should be in accordance with the relevant recommendations of the following British Standards:

BS 6798:1987 Specification for Installation of gas fired hot water boilers of rated input not exceeding 60 kW

BS 5449:1990 Central Heating for Domestic Premises

BS 5546:1990 Installation of gas hot water supplies for domestic purposes.

BS 5440:1:1990 Flues and Ventilation for gas appliances of rated input not exceeding 60kW: Flues.

BS 5440:2:1989 Flues and ventilation for gas appliances of rated input not exceeding 60kW: Air Supply.

BS 6891:1988 Installation of low pressure gas pipework installations up to 28mm (R1)

1.4 To ensure that the installation will perform to the highest standards, the system and components should conform to any other relevant British Standards in addition to those mentioned in the instructions.

1.5 The appliance complies with the Essential Requirements of the Gas Appliance Directive and other Directives currently applicable.

1.6 This appliance contains no asbestos products. There is no potential hazard due to the appliance being electrically unsafe. There are no substances used that are a potential hazard in relation to the COSHH Regulations 1988.

2. General Information

2.1 This appliance is not suitable for external installation.

2.2 The appliance controls are set to provide a maximum output of 24 kW for the hot water and a central heating load of up to 24 kW.

2.3 A permanent pilot is used to provide ignition.

2.4 PRINCIPLE APPLIANCE COMPONENTS

A low thermal capacity Gas to Water heat exchanger

A water to water heat exchanger to provide hot water.

A heatbank having a nominal capacity of 60 litres of circulating primary hot water positioned in the lower half of the appliance.

A water diverter valve to direct the boiler output either to hot water or central heating as required.

Multifunctional gas valve and electrical control system to individually control the hot water and central heating.

An integral circulating pump.

Boiler and hot water temperature control thermostats providing control for central heating and hot water.

A User's Operating Switch for selection of water only or heating and water.

A by-pass for central heating system.

A pump overrun thermostat which enables the pump to run on for a short period to allow the boiler section to cool to a preset temperature after each operating cycle.

An expansion vessel, pressure gauge and pressure relief valve.

Temperature safety cut-out controls.

A water flow regulator and flow switch in the domestic supply.

A standard horizontal rear flue kit to accommodate a flue length of 229mm to 407mm.

An optional flue kit to provide for flue lengths up to a maximum of 610mm.

2.5 ELECTRICAL SUPPLY

Mains supply: 230V ~ 50Hz, 150 watts. External fuse 3A. Internal fuse 3.15A (20mm) fast blow.

2.6 GAS SUPPLY

The boiler requires 2.84 m³/h (100.3 ft³/hr) of gas with a calorific value of 37.78 MJ/m³. (1014 Btu/ft³). The gas meter and supply pipes must be capable of supplying this quantity of gas in addition to the demand from any other appliances being served. The following table gives an indication of limiting gas pipe lengths and the allowance to be made for fittings. Refer to BS 6891 for further information.

The meter governor should deliver a dynamic pressure of 20 mbar (8in wg.) at the appliance.

The complete installation including the gas meter must be tested for soundness and purged. See BS 6891.

	Total Length of Gas Supply Pipe (metres)			Pipe Diameter (mm)
	3	6	9	
Gas Discharge Rate (m ³ /hr)	8.7	5.8	4.6	22
	18.0	12.0	9.4	28

2.7 PACKING

The appliance and flue components are packed in separate cartons.

2.8 GENERAL INSTALLATION

The appliance is supplied for connection to a sealed system but is suitable for use with an open system.

The specified ventilation openings made into a wall or compartment door must not be obstructed.

If the appliance is to be fitted into a compartment then the compartment must conform to the requirements of BS 6798: 1987:Section 6.

The clearances specified for installation and servicing must be maintained.

2.9 FLUE

The appliance has a balanced flue system.

A terminal guard, Type E, GC No 393 547, is available from Tower Flue Components, Vale Rise, Tonbridge, TN9 1TB.

The standard horizontal flue assembly length is from 229mm to 407mm.

Extended flue lengths up to 610mm are available using the optional extended flue kit.

Do not allow the flue terminal fitted to the outside wall to become obstructed or damaged.

2.10 CONTROLS

The electronic control system via the gas valve operates the heat input in response to the central heating and hot water temperature settings.

The Operating switch provides for the selection of hot water (WATER) only or central heating and hot water (HEATING and WATER) or OFF.

A fascia mounted programmer is available as an optional extra. A remote mounted programmer may be connected to the appliance.

The control thermostats for central heating and hot water are mounted on the integral fascia.

There is provision for the connection of a mains voltage room thermostat. Refer to Section 10.

Frost Protection. When the appliance and heating system are exposed to low temperatures it is advised to fit a frost thermostat Refer to Section 10.

Thermostatic radiator valves can be used in the system. The appliance incorporates an adjustable by-pass between the central heating flow and return.

Fig. 1. Appliance water flow diagram.

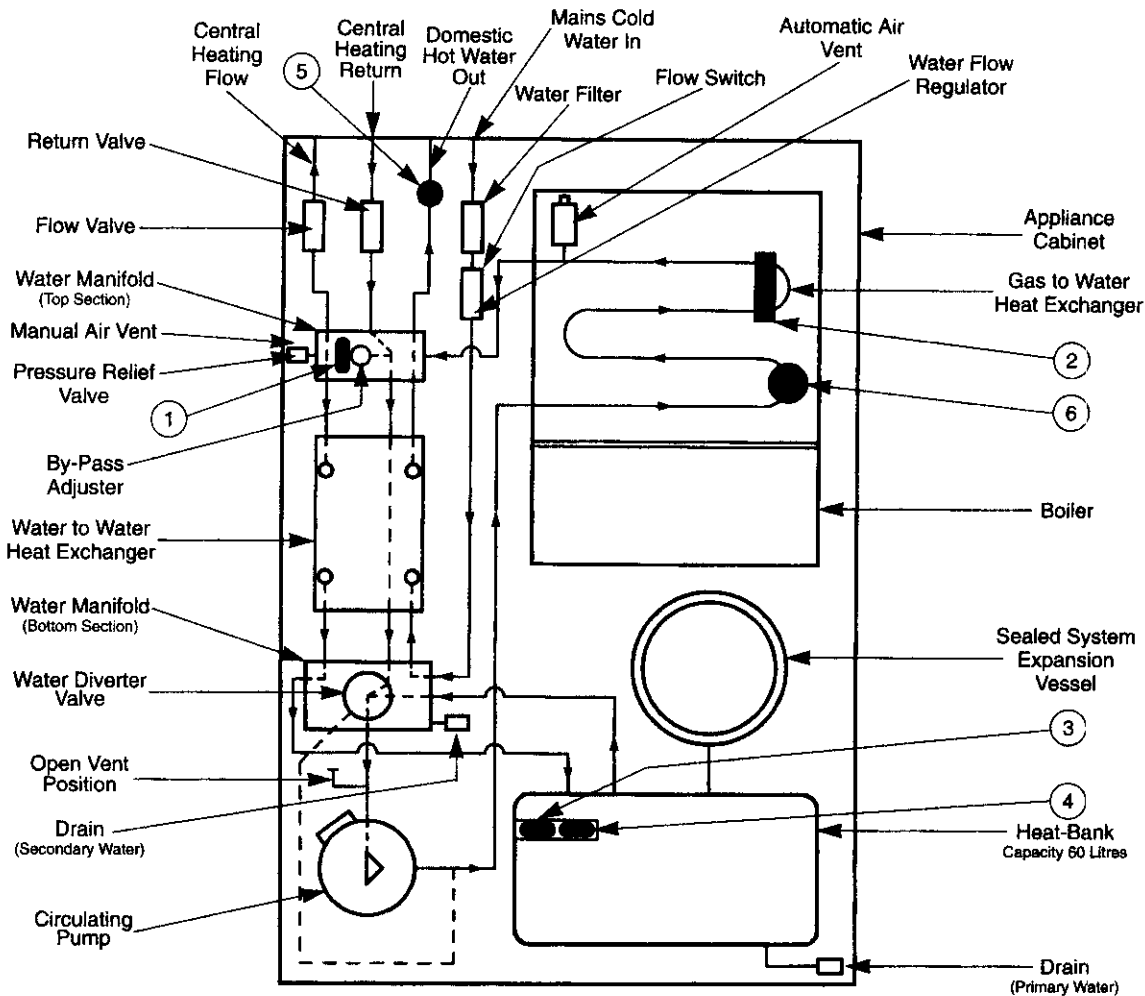

① C.H. Thermostat	ZAGAS041	④ Heatbank Overheat Thermostat	ZAGAS044
② Safety Temperature Limiter	SSAHAR013	⑤ H.W. High Limit Thermostat	SSAHAR253
③ H.W. Thermostat	ZAGAS042	⑥ Pump Over-run Thermostat	ZAMAJ165

2.11 SYSTEM NOTES

WARNING

CHECK THAT NO DIRT IS LEFT IN EITHER THE GAS OR WATER PIPEWORK AS THIS COULD CAUSE DAMAGE TO THE APPLIANCE. THE BOILER AND SYSTEM SHOULD BE FLUSHED OUT AND CLEANED AS PER BS 7593. THE DOMESTIC WATER SUPPLY SHOULD BE THOROUGHLY FLUSHED AND THE GAS SUPPLY PURGED BEFORE FINALLY CONNECTING THE APPLIANCE.

The water pipe connections throughout a sealed system must be capable of sustaining a pressure of up to 3 bar.

Radiator valves must conform to the requirements of BS 2767(10):1972.

The relief valve drain outlet must be directed away from any electrical components or where it would cause a hazard to the user.

A drain cock to BS 2879 must be fitted to the lowest point of the system.

For circuit design purposes it is important that due note is taken of the information given in Table 3 relating to the available pump head.

2.12 SHOWERS, BIDETS, TAPS AND MIXING VALVES

Hot and cold taps and mixing valves used in the system must be suitable for operating at a mains pressure of up to 10 bar.

Thermostatically controlled or pressure equalising shower valves will guard against the flow of water at too high a temperature.

Hot and cold mains fed water can be supplied direct to an over-rim flushing bidet subject to local water company requirements.

With all mains fed systems the flow of water from the individual taps will vary with the number of outlets operated simultaneously and the cold water mains supply pressure to the property. Flow balancing using 'Ball-o-Fix' type valves is recommended to avoid an excessive reduction in flow to individual outlets. For further information contact Worcester Heat Systems Ltd.

2.13 SAFETY CONSIDERATIONS

The appliance must not be operated in a waterless condition.

The appliance must not be operated with the boiler inner casing cover removed.

Work must not be carried out on the appliance without the gas and electricity supplies being turned off.

Checks must be made to ensure that the ventilation openings made into walls and partitions are of the correct size and are not obstructed.

2.14 OPERATION

See Fig. 1.

Hot Water Mode:

With the appliance in a stand-by condition, i.e. heatbank at the temperature set by the hot water control thermostat, burner off, pump off and a demand is made for hot water;

The flow switch will energise the pump and circulate primary hot water around the boiler and water to water heat exchanger. The burner will light at its maximum setting to maintain the temperature of the heatbank.

When hot water is no longer required the appliance will continue to operate, the burner will cycle a number of times, until the heatbank has returned to temperature. The pump will continue to run for a few minutes to dissipate the residual heat from the appliance around the central heating circuit.

Note: If it is required to use the appliance for hot water only or before the Central Heating circuit is connected a 22mm copper by-pass pipe must be connected between the Central Heating Flow and Central Heating Return. The minimum length of the by-pass pipe to be 2 metres.

Central Heating Mode:

With the appliance in a stand-by condition and a demand is made for heating:

The water diverter valve will open, the pump will energise circulating primary water around the heating system and the burner will light to the nominal setting pressure.

With the system at the temperature set by the Temperature Control Knob, on the fascia, the burner will cycle to maintain output to the system.

If the system no longer requires output to maintain the desired room temperature, the burner will extinguish. The pump will continue to run for a short period to dissipate the residual heat from the appliance and then switch off.

When the primary water has cooled sufficiently below the temperature set by the Temperature Control Knob, the burner will light, pump will energise and the process will be repeated.

Hot Water and Central Heating mode:

The appliance will supply heat to the central heating system as required. A demand for hot water at a tap or shower will override the central heating function for the period of the hot water demand.

When hot water is no longer required the burner and pump will continue to operate until the heatbank is back to the required temperature.

The appliance will return to the central heating state and its normal mode of operation.

3. Technical Data

See Fig. 2 and 3.

The Data Plate is fixed to the top of the control box casing.

Table 1

NOMINAL BOILER RATINGS (10 minutes after lighting the appliance)								
MODE	OUTPUT		INPUT		BURNER SETTING PRESSURE		GAS RATE	
	kW	Btu/h	kW	Btu/h	m bar.	in. wg.	m ³ /h	ft ³ /h
HEATING RANGE	8.8	(30,000)	11.6	(39,500)	2.2	0.9	1.11	39.2
	11.0	(37,000)	14.3	(48,600)	3.2	1.3	1.36	48.0
	13.0	(44,350)	16.6	(56,700)	4.4	1.8	1.58	55.5
	15.0	(51,200)	19.0	(64,850)	5.7	2.3	1.81	63.9
	17.0	(58,000)	21.4	(72,950)	7.2	2.9	2.04	72.0
	19.0	(64,800)	23.8	(81,150)	8.9	3.6	2.27	80.2
	21.0	(71,500)	26.2	(89,350)	10.7	4.3	2.50	88.3
	23.0	(78,500)	28.6	(97,600)	12.8	5.1	2.73	96.4
HOT WATER	24.0	(82,000)	29.8	(101,700)	14.1	5.6	2.84	100.3

Note: The appliance is factory pre-set to satisfy a central heating requirement of 15 kW (51,200 Btu/h). The output must be adjusted to suit the heating system when commissioning the appliance.

Table 2: Flue System.

FLUE DETAILS		
	mm	inches
WALL HOLE WIDTH	380	15.0
WALL HOLE DEPTH	280	11.0
STANDARD FLUE MINIMUM LENGTH	229	9.0
STANDARD FLUE MAXIMUM LENGTH	407	16.0
EXTENDED FLUE MAXIMUM LENGTH	610	24.0

Table 3

AVAILABLE PUMP HEAD							
	BOILER OUTPUT		HEAD		MIN. FLOW RATE		TEMPERATURE RISE ACROSS HEATING FLOW AND RETURN
	kW	Btu/h	Metres	Feet	L/min.	Gal/Min.	
HEATING RANGE	8.8	(30,000)	6.1	20.0	11.5	2.5	11°C (20°F)
	11.0	(37,000)	5.4	17.5	14.0	3.1	
	13.0	(44,350)	4.9	16.0	17.0	3.7	
	15.0	(51,200)	4.2	13.5	19.5	4.3	
	17.0	(58,000)	5.3	17.0	15.0	3.3	16°C (24°F)
	19.0	(64,800)	4.85	16.0	17.0	3.7	
	21.0	(71,500)	4.4	14.5	19.0	4.2	21°C (38°F)
	23.0	(78,500)	5.2	17.0	16.0	3.5	
24.0	(82,000)	5.0	16.5	16.5	3.6		

Table 4: Nominal Weight of Appliance

DRY WEIGHT OF APPLIANCE	96kg	(212lb)
PACKAGED WEIGHT OF APPLIANCE	98kg	(216lb)
MAXIMUM INSTALLATION WEIGHT	156kg	(344lb)

Table 5:

SPECIFICATIONS	
CENTRAL HEATING FLOW	22mm Copper Tube
CENTRAL HEATING RETURN	22mm Copper Tube
COLD WATER MAINS INLET	15mm Copper Tube
DOMESTIC HOT WATER OUTLET	22mm Copper Tube
GAS INLET	22mm Copper Tube
PRESSURE RELIEF VALVE DRAIN CONNECTION	22mm Copper Tube
OVERALL CASING HEIGHT	860mm (33.8 in.)
OVERALL CASING WIDTH	600mm (23.6 in.)
OVERALL CASING DEPTH	600mm (23.6 in.)

Table 6:

SPECIFICATIONS	
PRIMARY CAPACITY INCLUDING HEATBANK	60 Litres (13.2 galls.)
MAXIMUM INLET DOMESTIC WATER PRESSURE	10 Bar (150 psi)
MINIMUM INLET DOMESTIC WATER PRESSURE (WORKING) FOR MAXIMUM HOT WATER FLOW	1.0 Bar (15.0 psi)
MINIMUM INLET DOMESTIC WATER PRESSURE (WORKING) TO OPERATE THE APPLIANCE	0.1 Bar (1.5 psi)
MAXIMUM CENTRAL HEATING FLOW TEMPERATURE	Nominally 82°C (180°F)
MAXIMUM STATIC HEAD – PRIMARY	30m (97ft.)
MINIMUM STATIC HEAD – PRIMARY	1.0m (3.3ft.)
OUTPUT TO DOMESTIC HOT WATER	24.0kW (82,000 Btu/h)
OUTPUT TO CENTRAL HEATING	8.8 to 24.0kW (Adjustable) (30,000 to 82,000 Btu/h)
MAXIMUM DOMESTIC HOT WATER FLOW RATE FROM THE APPLIANCE EQUIVALENT HOT WATER FLOW RATE FROM THIS APPLIANCE TO GIVE 30°C RISE (SPECIFIC RATE)	Nominally 18.0 l/min. ± 15% (3.96 gall/m) 20 l/min. (4 gall/m)

4. Siting The Appliance

4.1 THE APPLIANCE MAY BE INSTALLED IN ANY ROOM ALTHOUGH PARTICULAR ATTENTION IS DRAWN TO THE REQUIREMENTS OF THE CURRENT I.E.E. WIRING REGULATIONS AND, IN SCOTLAND, THE ELECTRICAL PROVISIONS OF THE BUILDING REGULATIONS APPLICABLE IN SCOTLAND, WITH RESPECT TO THE INSTALLATION OF APPLIANCES IN ROOMS CONTAINING BATHS OR SHOWERS. WHERE A ROOM SEALED APPLIANCE IS INSTALLED IN A ROOM CONTAINING A BATH OR SHOWER, ANY ELECTRICAL SWITCH OR APPLIANCE CONTROL USING MAINS ELECTRICITY MUST NOT BE ABLE TO BE TOUCHED BY A PERSON USING THE BATH OR SHOWER.

4.2 The appliance is not suitable for external installation.

4.3 The appliance is floor standing, the floor must be firm and level. Special floor protection is not required.

4.4 The floor must be capable of supporting the weight of the appliance. Refer to Section 3 Table 4.

4.5 If the appliance is to be fitted in a timber framed building refer to the British Gas publication "Guide for Gas Installations in Timber Framed Housing".

4.6 The following clearances must be available for installation and for servicing. See Fig. 2.

	Installation	Service
Above the appliance	450mm	10mm
In front	600mm	600mm
Right side	5mm	5mm
Left side	300mm	5mm

4.7 The appliance can be installed in a cupboard to be used for airing clothes provided that the requirements of BS 6798 and BS 5440:2 are strictly followed.

4.8 The airing space must be separated from the boiler space by a perforated non-combustible partition. Expanded metal or rigid wire mesh are acceptable provided that the major dimension is less than 13mm. See BS 6798:1987.

4.9 No combustible surface must be within 75mm of the casing. See BS476:4.

4.10 The distance between the inner face of a cupboard door and the cabinet front should not be less than 75mm.

4.11 Always consider the possible need to disconnect the pipes from the appliance after installation.

4.12 L.P.G. INSTALLATION

The appliance shall not be installed in a room or internal space below ground level when it is intended for use with L.P.G. This does not preclude the installation into rooms which are basements with respect to one side of the building but open to ground level on the opposite side.

Fig. 2. Appliance cabinet dimensions and minimum clearances required.

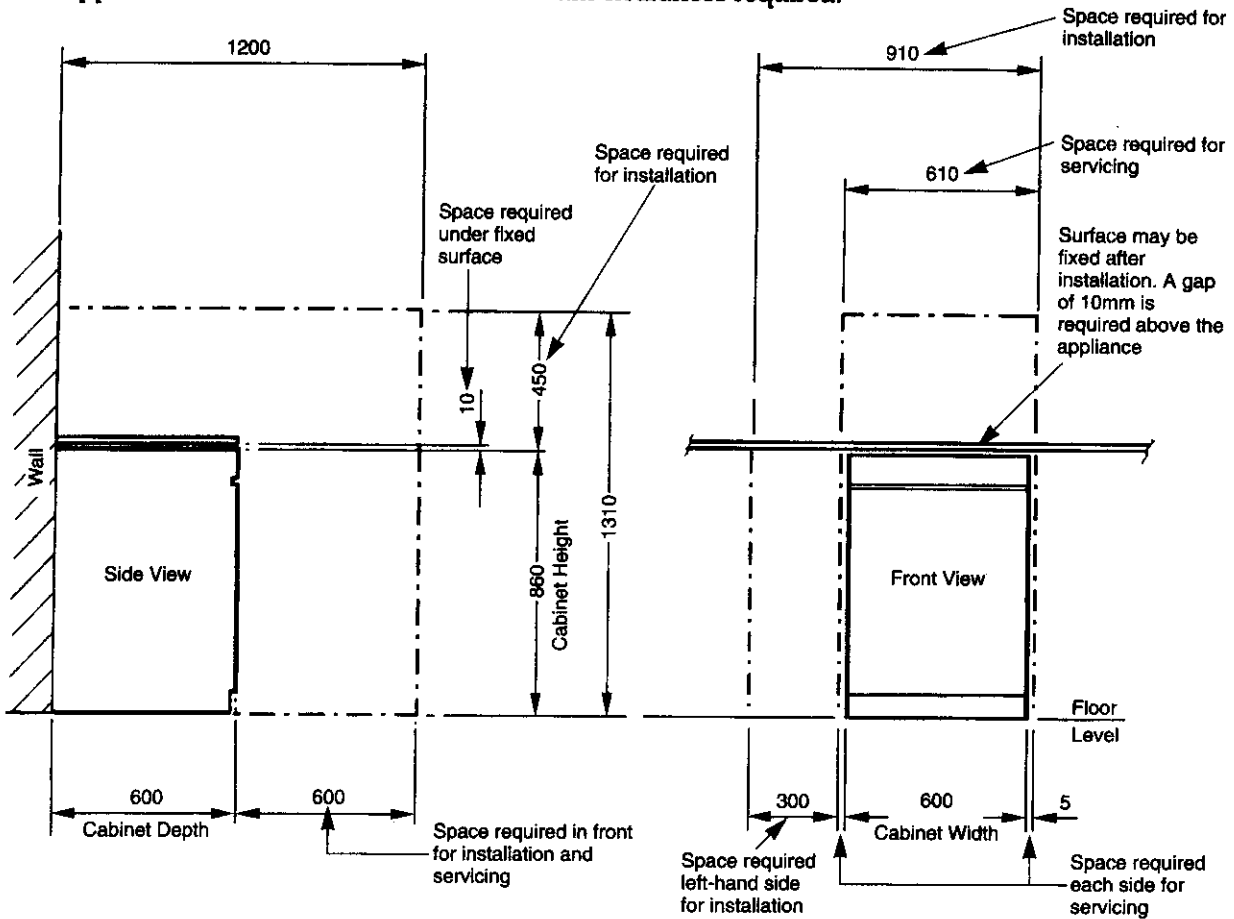

Fig. 3. Appliance pipework connections and flue position.

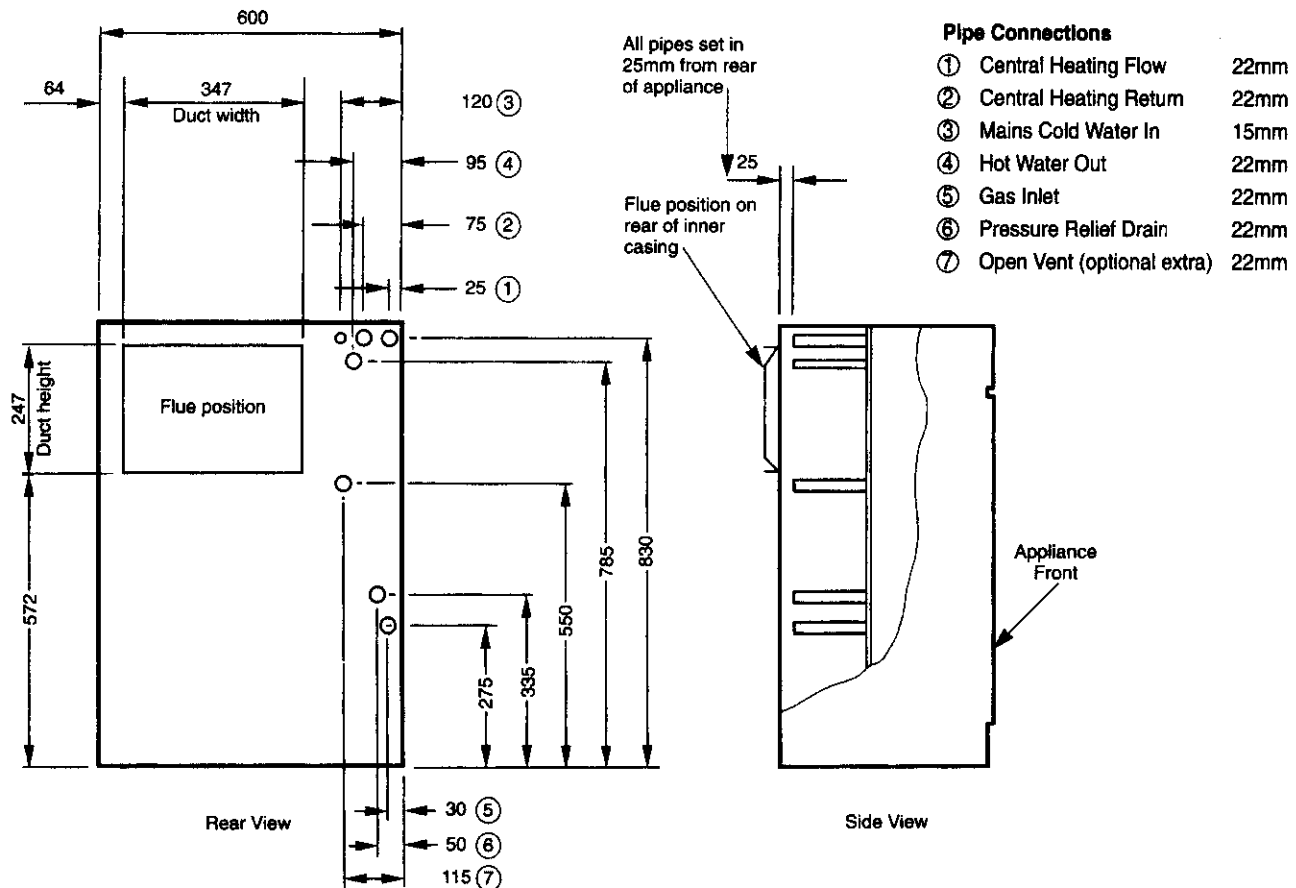
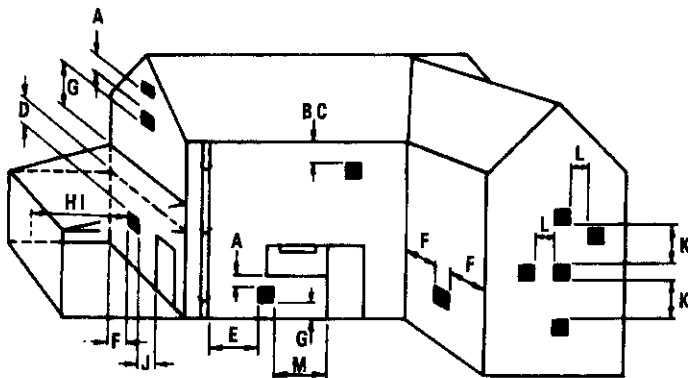

Fig. 4. Siting of the flue terminal.

MINIMUM SITING DIMENSIONS FOR POSITIONING THE BALANCED FLUE TERMINAL



TERMINAL POSITION	MIN. DISTANCE
A- directly below an openable window or other opening e.g. air brick.	300mm (12 in.)
B- Below gutters, soil pipes or drain pipes.	300mm (12 in.)
C- Below eaves.	300mm (12 in.)
D- Below balconies or car port roof.	600mm (24 in.)
E- From vertical drain pipes and soil pipes.	75mm (3 in.)
F- From internal or external corners.	600mm (24 in.)
G- Above ground, roof or balcony level.	300mm (12 in.)
H- From a surface facing a terminal.	600mm (24 in.)
I- From a terminal facing a terminal	600mm (24 in.)
J- From an opening in a car port (e.g. door window) into dwelling.	1200mm (47 in.)
K- Vertically from a terminal on the same wall.	1500mm (59 in.)
L- Horizontally from a terminal on the same wall.	300mm (12 in.)
M- From door, window or air vent (achieve where possible).	300mm (12 in.)

5. Flue Terminal Position

- 5.1 The flue must be installed as specified by BS 5440:Part 1.
- 5.2 **TERMINAL POSITION.** See Fig. 4.
- 5.3 The terminal must not cause an obstruction nor the discharge a nuisance.
- 5.4 If the terminal is fitted within 850mm of a plastic or painted gutter or within 450mm of painted eaves then an aluminium shield at least 750mm long should be fitted to the underside of the gutter or painted surface.
- 5.5 If a terminal is fitted less than 2 metres above a surface to which people have access then a guard must be fitted. Refer to Section 2, Item 2.9.
- 5.6 The terminal guard must be evenly spaced about the flue terminal and fixed to the wall using plated screws
- 5.7 In certain weather conditions a terminal may steam and siting where this could cause a nuisance should be avoided.
- 5.8 Take care to ensure that combustion products do not enter ventilated roof voids.

6. Air Supply

- 6.1 The appliance does not require a separate vent for combustion air.
- 6.2 Installations in cupboards or compartments require permanent vents for cooling purposes, one at high level and one at low level, either direct to outside air or to a room. Both vents must pass to the same room or be on the same wall to the outside air.
- 6.3 There must be sufficient clearance around the appliance to allow proper circulation of ventilation air. Refer to Section 4, Item 4.6.
- 6.4 The minimum free areas required are given below.

POSITION OF VENTS	AIR FROM THE ROOM	AIR DIRECT FROM OUTSIDE
HIGH LEVEL	270 cm ² (42 in ²)	135 cm ² (21 in ²)
LOW LEVEL	270 cm ² (42 in ²)	135 cm ² (21 in ²)

- 6.5 Refer to BS 6798 and BS 5440:2 for additional information.

7. Sealed System

See Fig. 5. and .6.

7.1 The system must comply with the requirements of BS 6798 and BS 5449:1.

7.2 The appliance must not be operated without the system being full of water, properly vented and pressurised.

7.3 The safety valve operates at 3bar (45lb/in²). The discharge must be directed away from electrical items or where it might be a hazard to the user.

7.4 The pressure gauge indicates the system pressure which must be maintained.

7.5 The 12 litre expansion vessel is charged to 0.5 bar and is suitable for a static head of 5m (17.5ft). The pressure can be increased if the static head is greater than 5m (17.5ft).

7.6 With an initial system pressure of 0.5 bar, a system capacity of about 104 litres can be accommodated. Refer to BS 7074 Pt 1 for more information.

7.7 The filling point must be at low level. See Fig. 5.

7.8 Water loss must be replaced. See Fig. 6. The connection should be made in the central heating return as close to the appliance as possible.

7.9 The make-up vessel must be fitted with a non-return valve.

7.10 Repeated venting loses water from the system. It is essential that this water is replaced and the system pressure maintained.

7.11 There must be no connection to the mains water without the authority of the local Water Company.

7.12 The pump is set at maximum and must not be adjusted.

7.13 Connections in the system must resist a pressure of up to 3 bar.

7.14 Radiator valves must conform to BS 2767(10):1972.

7.15 Other valves used should conform to the requirements of BS 1010.

7.16 To make use of the extra heat available from the appliance at the end of any demand, it is recommended that a single small radiator be left permanently open.

7.17 If it is required to use the appliance for Hot Water before the Central Heating Circuit is connected a 22mm copper by-pass must be connected between the Central Heating Flow and Central Heating Return. Refer to Section 11.

Fig. 5. Sealed primary water system.

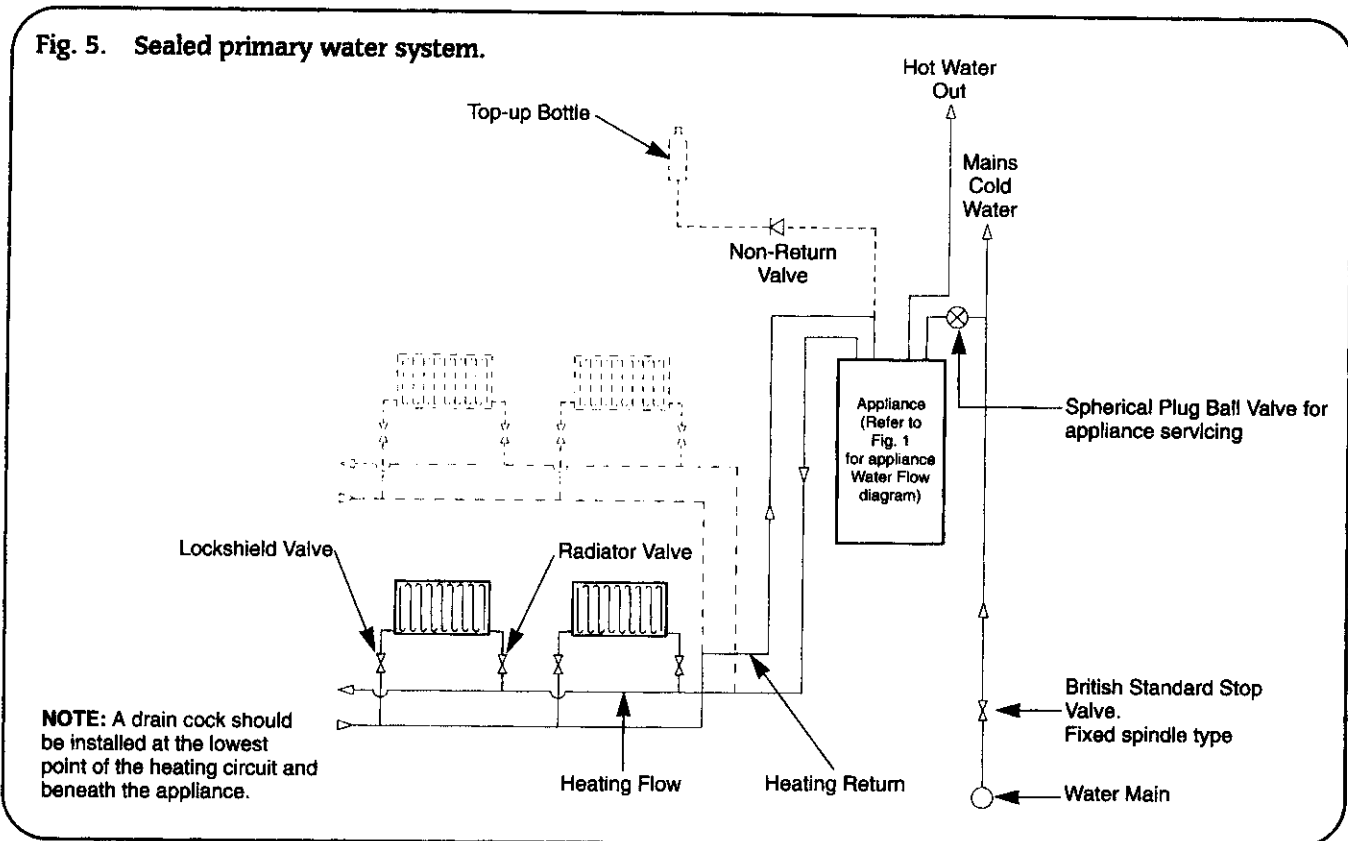
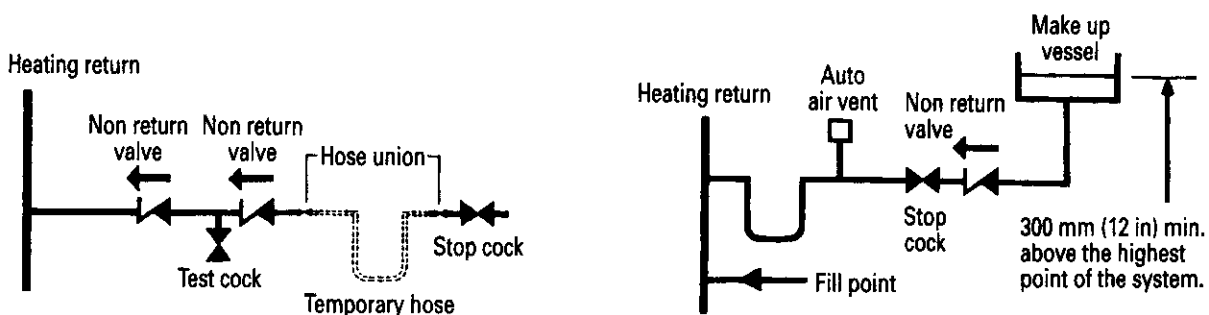

Fig. 6. System filling and make-up.



8. Open Vent Primary System

See Fig. 7 and 19.

8.1 The appliance is supplied suitable for connection to a sealed system. If it is to be used with an open vent system then the instructions given below must be followed.

8.2 A 22mm preformed combined feed and vent pipe available as an optional extra must be connected to the appliance. See Section 11.3 and Fig. 19.

Note: Refer to Section 3, Table 5, for the sizes of the flow and return pipework.

8.3 The feed and expansion cistern should be arranged so that a minimum static head of 1.0m (3.3 ft) above the top of the appliance or above the highest point in the heating circuit, whichever is the highest, is achieved. See Fig. 7.

8.4 The feed and vent pipe must rise continuously from the appliance to the feed and expansion cistern.

8.5 A safety valve is not required on an open vented system. With the safety valve left in position then a pipe must be fitted which terminates such that any discharge does not cause a hazard to the occupants or damage to electrical components.

8.6 Air within the appliance will be expelled via the feed and vent connection or dissipated into the rest of the system which must be fitted with manual air vents at any high points.

8.7 The pump is set to maximum and must not be reset.

8.8 To make use of the extra heat available from the appliance at the end of any demand, it is recommended that a single small radiator be left permanently open.

8.9 If it is required to use the appliance for Hot Water before the Central Heating Circuit is connected a 22mm copper by-pass must be connected between the Central Heating Flow and Central Heating Return. Refer to Section 11.

Fig. 7. Open vent water system.

STATIC HEAD (S.H.)

Minimum Static Head 1.0m (3ft). Measured from the top surface of the appliance or the highest point in the heating system to the water level in the feed and expansion tank.

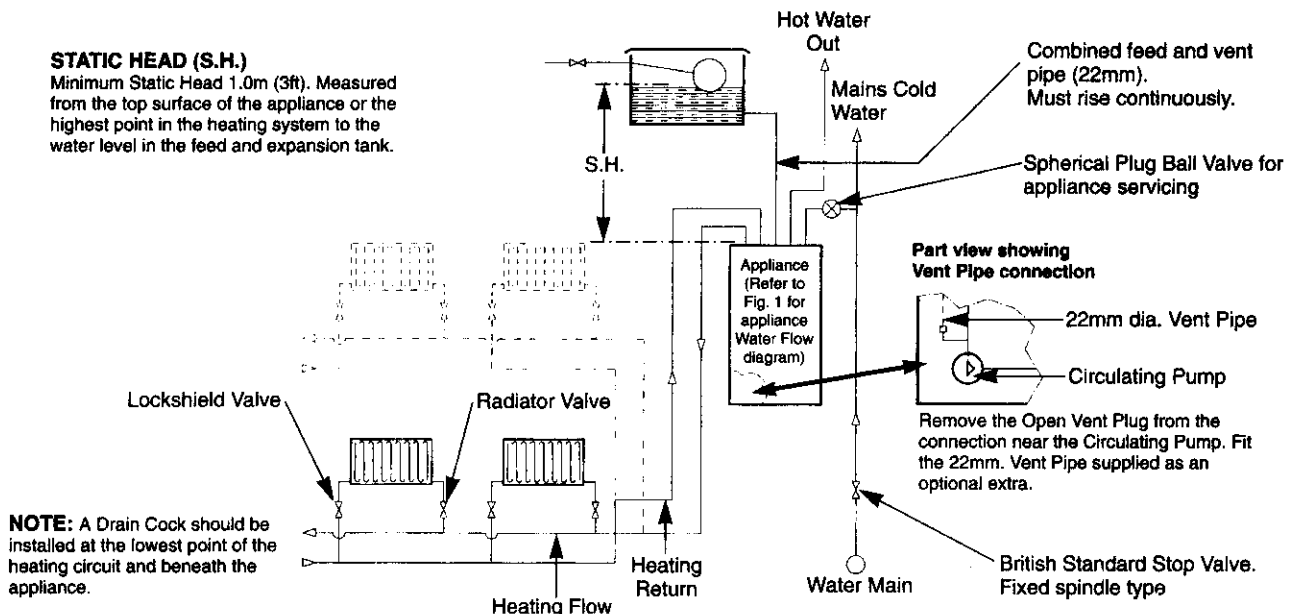

9. Domestic Water Supply

9.1 The final 600mm of the mains cold water connection to the appliance should be made in copper tube only.

9.2 The appliance is suitable for a mains pressure of up to 10 bar (150 lb/in²).

9.3 The appliance is fitted with a mains supply isolating valve.

9.4 The maximum hot water flow rate is 18 l/min \pm 15% (3.9 gall/min).

9.5 In winter, when the mains inlet water temperature is lower a reduced flow rate, achieved at the tap, will increase the required delivery temperature.

9.6 It is suggested that long pipe runs to the taps or shower should be insulated to prevent the rapid cooling of hot water after the tap or shower has been turned off.

9.7 Hot and cold taps and mixing valves used with this appliance must be suitable for operating at a pressure of up to 10 bar (150 lb/in²).

9.8 Anti-syphonage arrangements are normally not necessary. See paragraph 9.10 following.

9.9 Thermostatically controlled or pressure equalising shower valves will guard against the flow of water at too high a temperature.

9.10 The head of a loose head shower must not fall closer than 25mm (1 in) above the top edge of the bath to prevent its immersion in bath water. Alternatively the shower must be fitted with an anti-syphonage device at the point of the flexible hose connections.

9.11 The supply of hot and cold mains water direct to a bidet is permitted, subject to local Water Company requirements, provided that the bidet is of the over-rim flushing type. The outlet(s) should be shrouded and unable to have any temporary hand held spray attached. No anti-syphonage arrangements are necessary.

9.12 As the maximum temperature of the hot water heat exchanger is limited by the control circuit, there is normally no need for water treatment to prevent scale accumulation. In exceptional circumstances a device to prevent scale formation can be fitted.

9.13 Installation of a scale inhibitor assembly should be in accordance with the requirements of the local Water Company. An isolating valve to allow servicing should be fitted.

9.14 The water hardness can be determined using a standard test paper or by reference to the local water company.

9.15 A miniature expansion vessel (Zilmet R¹/₂, 160 ml, 15 bar), available as an optional extra, may be fitted into the domestic water supply circuit if there is evidence of water hammer.

To fit the expansion vessel:

- (i) Remove the front cover. Refer to Section 14 paragraph 14.2 a, and Fig. 16.
- (ii) Unscrew the hexagon headed screw located below the flow switch. See Fig. 16.
- (iii) Screw the expansion vessel into the connection using thread sealant compatible with potable water.

9.16 Note: If it is required to use the appliance for Hot Water before the Central Heating Circuit is connected a 22mm copper by-pass must be connected between the Central Heating Flow and Return. Refer to Section 11.

10. Electrical

Refer to Figs. 8, 9, 10 and 11.

10.1 Mains Supply 230V ~ 50Hz 150 watts. External Fuse 3A. Internal Fuse 3.15A (20mm) fast blow.

10.2 The electrical supply must be connected by a qualified electrician..

10.3 A fused double pole isolator with a contact separation of 3mm in all poles **MUST** be used to supply the appliance and controls.

10.4 The appliance must be earthed.

10.5 Mains Cable: PVC insulated 0.75mm² (24x0.20mm) to BS 6500 Table 16. If a new cable is needed it must be connected into the terminals marked L (Brown or Red lead), N (Blue or Black lead) and \perp (Green/Yellow or Green) and be held securely in the cable clamp. Ensure the Earth conductor is longer than the

current carrying conductor, so that if the cable slips in its anchorage, the current carrying conductors become taut before the Earth conductor. For access refer to Section 14.

10.6 The wiring between the appliance and the electrical supply shall comply with current IEE Wiring Regulations, and any local regulations which apply.

10.7 If a room and/or frost thermostat is to be fitted refer to Fig.10.

The thermostats must be suitable for use on mains voltage.

10.8 A facia mounted programmer is available as an extra. Instructions are supplied with the programmer kit. See Fig. 11.

10.9 A timeswitch or programmer can be fitted externally to the appliance.

10.10 SAFETY CHECK

After installation or in the event of an electrical fault the electrical system shall be checked for short circuits, fuse failure, incorrect polarity of connections, earth continuity and resistance to earth.

Fig. 8. Wiring diagram.

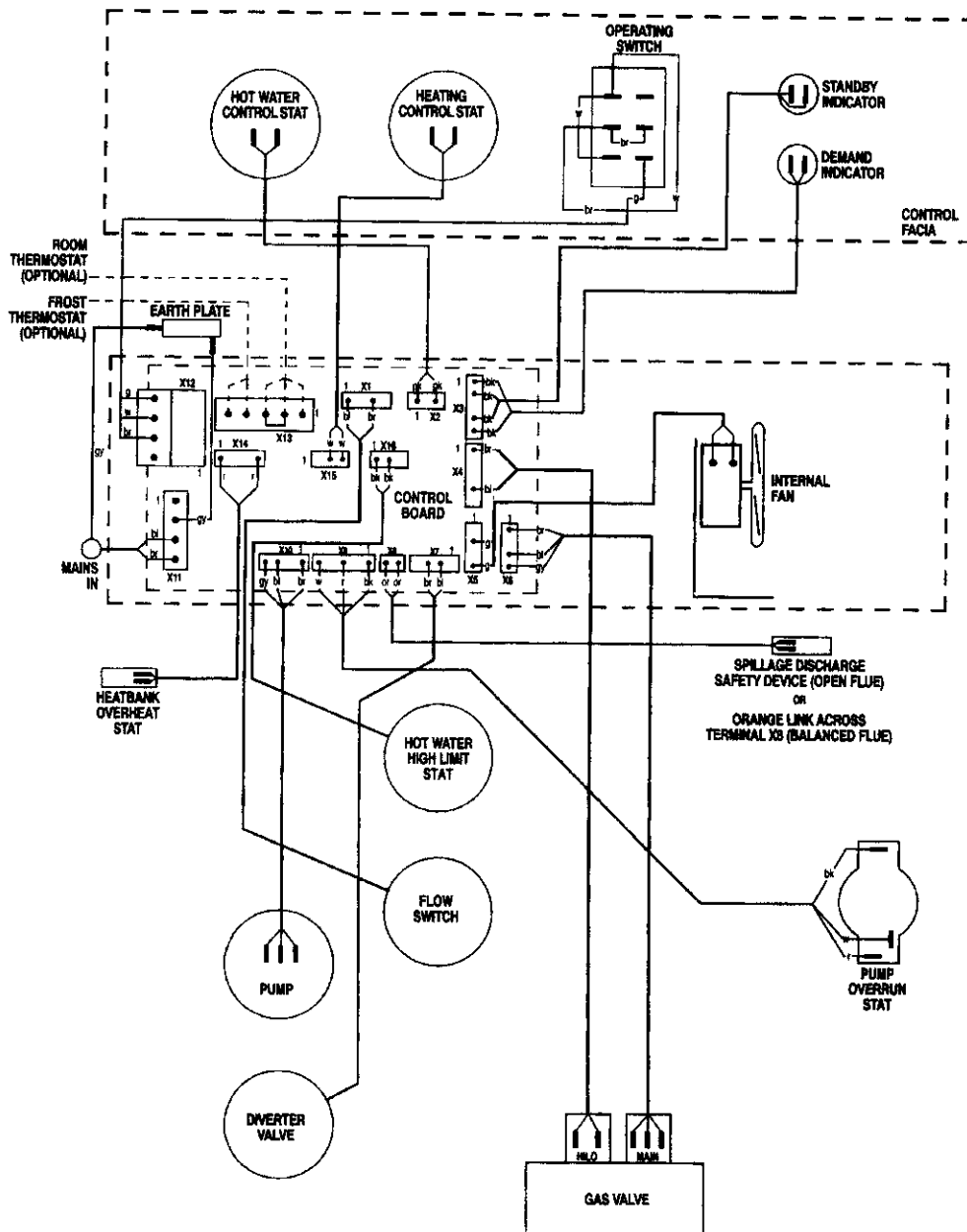

Fig. 9. Functional flow diagram.

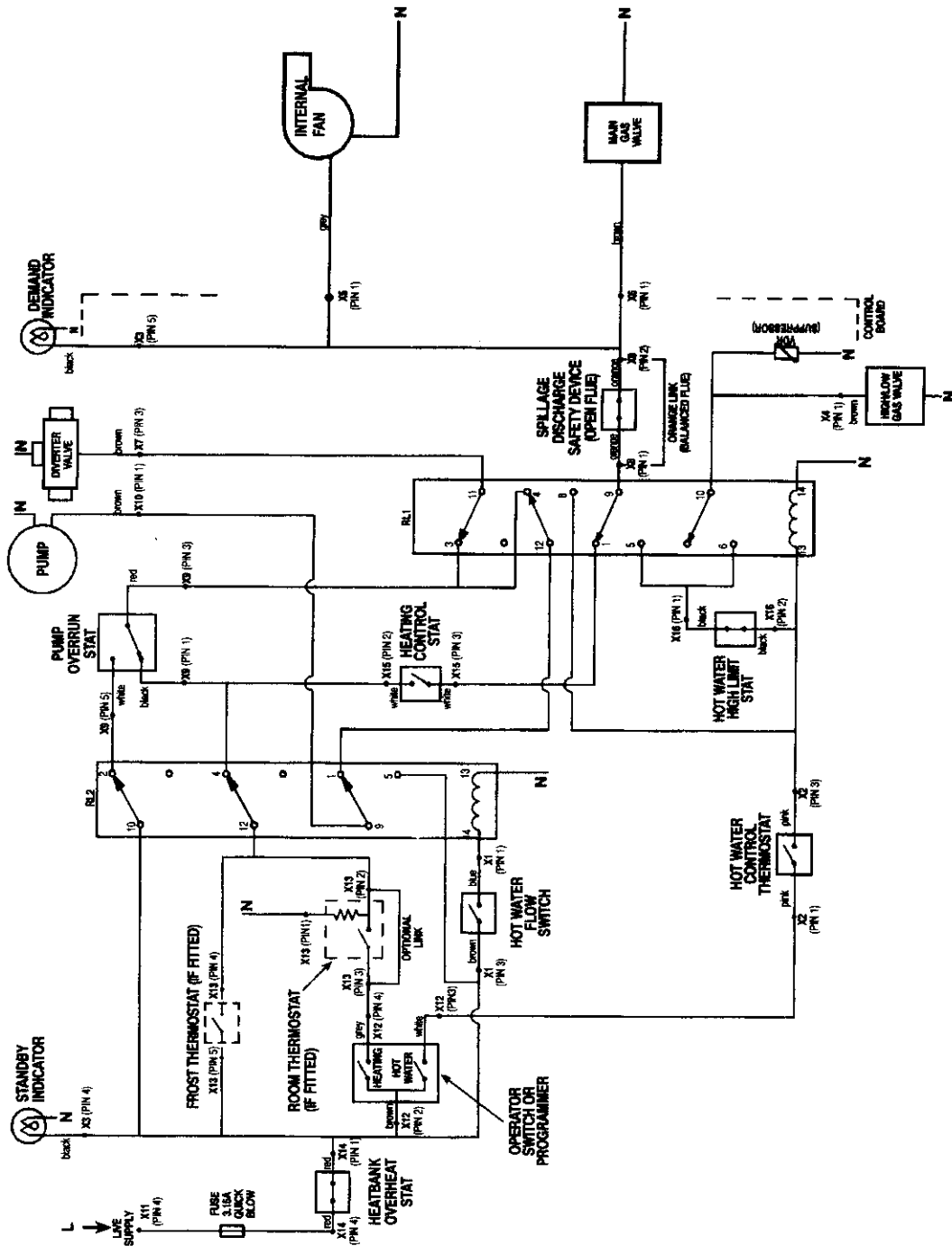

Fig. 10. Room/frost thermostats and programmer.

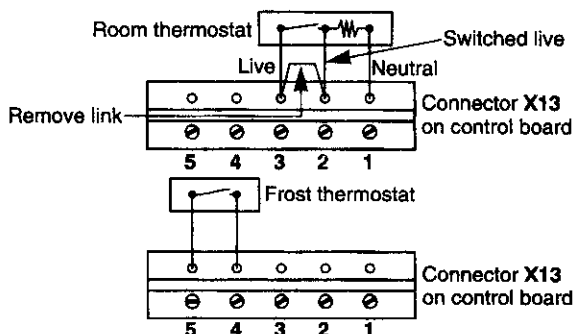
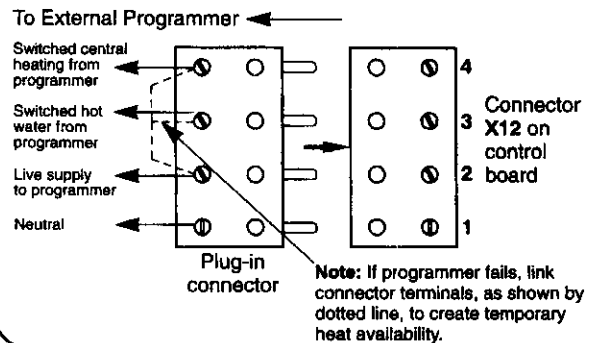

Fig. 11. External programmer connections.



11. Installing The Appliance

The appliance is supplied suitable for fitting to a sealed system. If it is to be fitted to an open vent system refer to paragraph 11.3 and Section 8.

11.1 GENERAL FITTING

The following description covers one method of installation. Extra space may be required for installation if connections are made in a different way.

Compression fittings may be used on all water connections to allow for the fitting of the appliance and servicing.

Pipework must be routed so as not to obstruct access to the circulating pump, diverting valve, gas valve, water to water heat exchanger or heat bank.

Removable sections are provided in the cabinet top panel to facilitate vertical pipe connections if required.

Check that the appliance carton contains :

- Installer's Instruction Pack
- User's Information Pack
- Hardware Pack.
- Appliance

Carefully remove the appliance from the cardboard package and plinth.

Check the position chosen for the appliance is in accordance with the instructions given in Sections 4 and 5.

Also refer to Fig. 2.

Do not place the appliance in its final position at this stage.

The weight of the appliance empty is 96 Kg., more than one person may be required when moving the appliance.

Depending on site conditions it may be helpful to pre-plumb the appliance before moving it into position. Fitting unions or stub pipes to the appliance pipework should be done at this stage. Refer to Section 3 and Fig. 3.

Before the appliance is fitted to the central heating system, thoroughly flush the heating system and the mains cold water supply pipe.

To gain access to the appliance remove the cabinet front and top panel and place the fascia and control box in the Service Position:

- (i) Lift the cabinet front panel off the top location and clear the lower return over the kick strip. See Fig. 12.
- (ii) Unscrew the two screws securing the fascia to the outer edges of the cabinet accessible under the fascia. Ease the fascia and control box forwards on the slide rails until fully extended. See Fig. 12.
- (iii) Lift the assembly upwards through 90° into the Service Position. Lodge in the Service Position on the outer locations. See Fig. 12.
- (iv) Unscrew the two screws behind the control panel securing the cabinet top panel. See Fig. 12.
- (v) Lower the fascia and control box to the fully extended position. Ease the cabinet top panel forwards approximately 20mm and lift clear of the appliance. See Fig. 12. Return the fascia and control box to the Service Position.

11.2 FLUE PREPARATION

Having decided upon the most suitable position for the appliance the hole for the balanced flue assembly must now be marked on the wall.

From the dimensions given in Fig. 13 carefully mark the wall to position the hole for the balanced flue assembly.

Cut a hole in the wall 380mm (15.0 in.) wide x 280mm (11.0 in.) high for the balanced flue air duct. Make good any plaster or brickwork.

Measure the wall thickness **W** from the inner face of the wall to the outside face. See Fig. 13.

From the carton containing the flue kit (either standard or extended) remove the flue terminal, flue duct, air duct and the package containing the following items :-

- 4 off - M5 Hex Head screws
- 2 off - M5 Shakeproof Washers
- 4 off - No 8 wall plugs
- 4 off - No 8 wood screws
- 1 off - roll of ducting tape
- 1 off - tube of silicon sealant

Fit the air ducts together and adjust their total length until it corresponds with the dimension **W** + 40mm.

Using the ducting tape provided firmly tape the joint. See Fig. 14. Check the total length before continuing.

Apply the silicone sealant in a bead approximately 10mm (0.3 in) diameter around the air duct spigot located on the rear of the inner casing. See Fig. 15.

Fit the air duct to the appliance, secure with the two M5 bolts and shakeproof washers provided, through the holes in the rear of the inner casing. See Fig. 15.

Carefully slide the appliance into the final position, passing the air duct through the hole in the wall, with the rear of the appliance base plate parallel with the wall or skirting board. See Fig. 15.

Remove one screw holding the expansion vessel in position and gently lower until resting on the floor. See Fig. 16.

Unscrew the four screws securing the inner casing cover. Remove the cover. See Fig. 16.

Remove the two screws fixing the front of the flue hood to the top of the combustion chamber. Ease the flue hood clear of the combustion chamber. See Fig. 15.

From outside, make good the gap between the air duct and the brickwork. Ensure the air duct is not distorted when filling the gap.

Fit the flue terminal to the air duct and mark the position of the four fixing holes. Drill four holes 5mm (0.19 in.) diameter x 30mm (1.25 in.) deep in the wall and fit the wall plugs provided.

Fix the flue terminal to the wall using the four No. 8 wood screws.

Note: The flue terminal is not symmetrical and the narrow air inlet gap is at the top. The top flange is marked **TOP**.

From inside the appliance enter the flue duct, plain end first. Engage the flue duct over the front half of the flue duct attached to the flue terminal. Slide in the flue duct and secure the flange to the inner casing with the screws provided but do not tighten. See Fig. 15.

Engage the spigot on the flue hood into the flue duct and slide into position on the heat exchanger. Fix into position with the two screws at the front.

Tighten the screws securing the flange of the flue duct to the inner casing.

11.3 FIXING THE APPLIANCE

Always support the appliance pipework when tightening.

Sealed System.

Connect a 22mm copper drain pipe to the discharge connection at the rear of the appliance.

Ensure:

- (i) any discharge does not fall onto electrical components or where it might be a hazard to the user. See Fig. 18.
- (ii) the pipe must fall throughout its length.

Open Vent System.

If the appliance is to be used on an open vent system remove the open plug from the bottom manifold connection. Fit the 22mm copper vent pipe, supplied as an optional extra, to this connection. See Fig. 19.

To access the open vent connection remove the pump head. Withdraw the two securing clips from the pump body. Ease the pump forwards about 10mm off the "O" ring seals. It is not necessary to disconnect the electrical cable. The cable is sufficient to allow the pump head to rest on top of the appliance. Do not allow the pump head to be suspended by the cable. Secure the pump head. See Figs. 16 and 19.

Note: Hot Water only.

If required the appliance may be used for Hot Water before Central Heating is connected. A 22mm copper by-pass pipe at least 2 metres long must be connected between the Central Heating Flow and Central Heating Return.

Connect the gas pipe to the gas inlet on the appliance at the left hand side.

Connect the water system pipes at the rear of the appliance.

Thoroughly flush the whole of the water system with cold water. Fill the system venting the appliance and check for water soundness. Refer to Section 12.

Reassemble the cabinet top panel. Do not replace the inner casing front or cabinet front until the commissioning has taken place. Refer to 11.4 and Section 12.

11.4 FINAL INSTALLATION

Check that all the water connections and the gas connection have been tightened.

Facia Mounted Programmer (where applicable).

Remove the facia panel as described in Section 11.1. Refer to Fig. 12.

Unplug the Operating Switch connection at the control board. Unscrew and retain the four nuts and washers securing the switch mounting plate to the facia. Remove the plate. Fit the programmer to the facia and fix using the four nuts and washers. Plug the lead into the connection on the control board. See Fig. 11. The programmer can be set when the electricity supply has been turned on at the commissioning stage.

Connect the mains electricity supply to the appliance and connect any room and/or frost thermostats. Refer to Section 10, Figs. 8 and 10. The leads from the thermostats must pass through holes provided in the control box at the right hand side and be clamped using the strain relief bushes provided in the pack. Check that the control box and facia can be withdrawn into the Service Position before fixing any leads outside the appliance.

Refit the control box and facia in the reverse order.

Test the gas supply for soundness as indicated in BS 6891.

If the appliance is not to be commissioned immediately, replace the inner casing front cover, expansion vessel and cabinet front panel. See Fig. 12

Check that the gas supply, the electricity supply and the water connections are all turned off.

Fig. 12. Cabinet, facia, control box and flue assembly fixing screws.

To gain access to the appliance:

1. Lift cabinet front panel L off top location and clear the return edge over the kick strip.
2. Remove screws A and ease facia and control box forwards on the slide rails.
3. Remove screws B, accessible under cabinet top panel. Ease panel forwards clear of location C and remove.
4. Lift facia and control box through 90° into the service position. Lodge in position on the outer locations.

To gain access to the control box from the service position:

1. Pull the thermostat knobs F and G clear of the facia.
2. Remove screws E.
3. Ease facia out of control box. Take care not to over stretch the capillary tubes or wiring.
4. Support the facia out of the control box when carrying out installation or service operations.

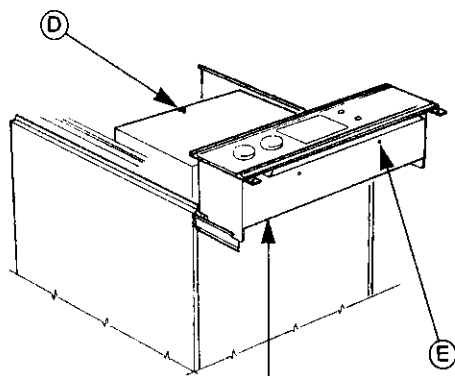
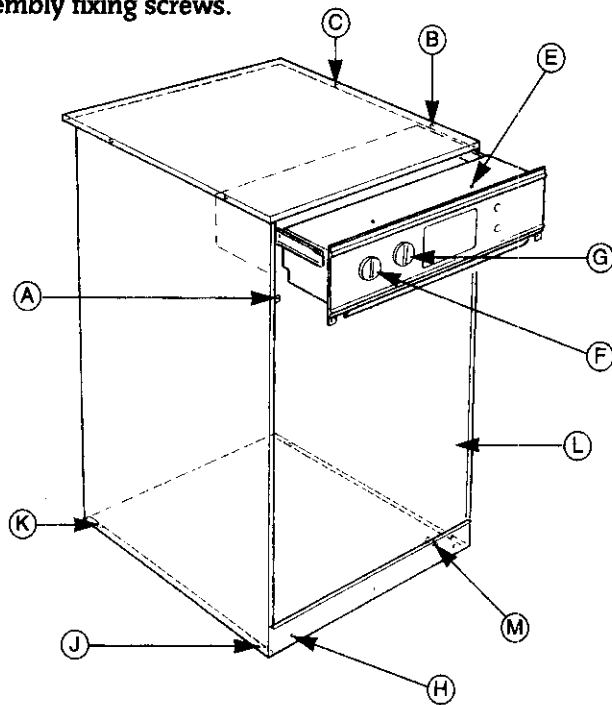

Lift facia and control box into the service position

- (A) Facia and control box fixing screws
- (B) Cabinet top panel fixing screws
- (C) Cabinet to panel fixing lugs
- (D) Flue assembly clamping screw
- (E) Facia fixing screws
- (F) Hot water control thermostat knob
- (G) Heating control thermostat knob
- (H) Kick strip fixing screws
- (J) Cabinet side panel front location
- (K) Cabinet side panel fixing lugs
- (L) Cabinet front panel (no fastenings)
- (M) Primary system drain. Remove kick strip for access

Fig. 13. Balanced flue appliance wall preparation.

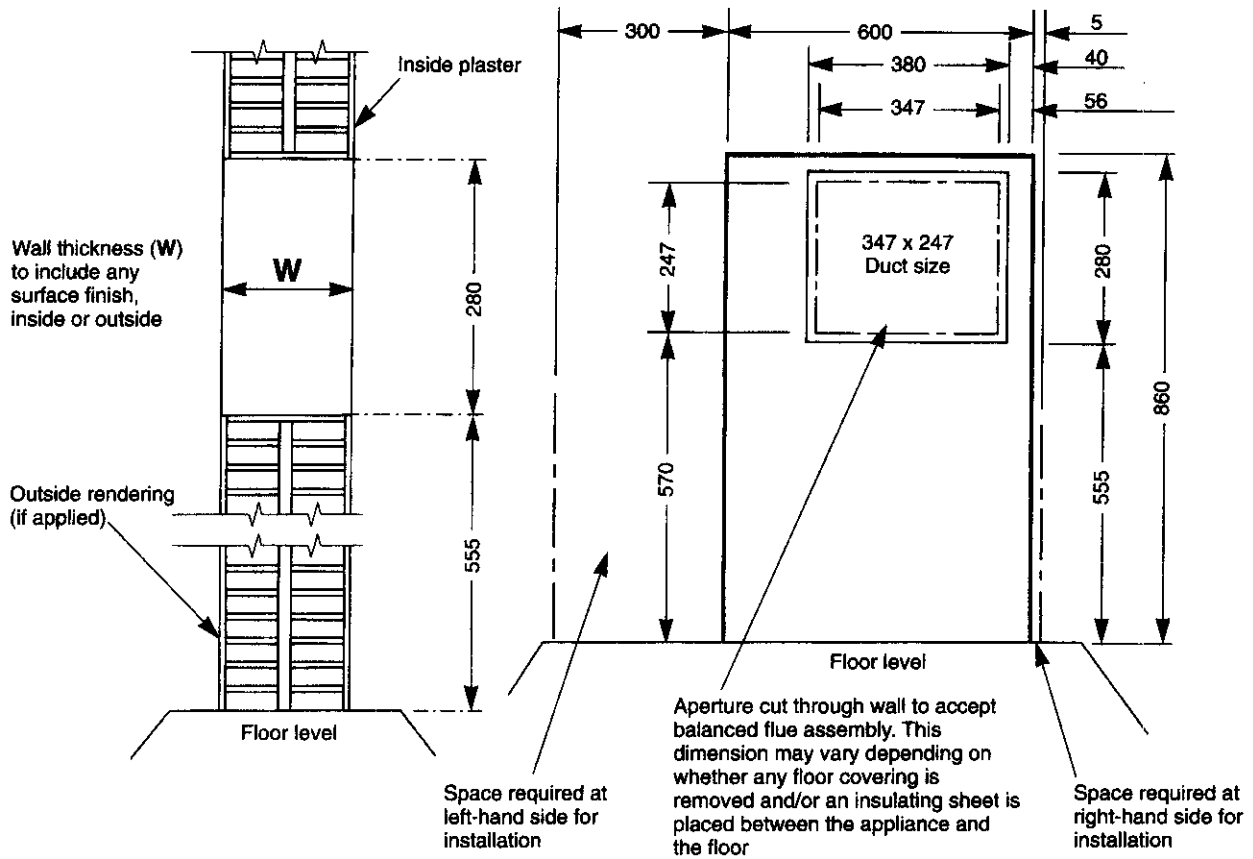

Fig. 14. Air duct adjustment.

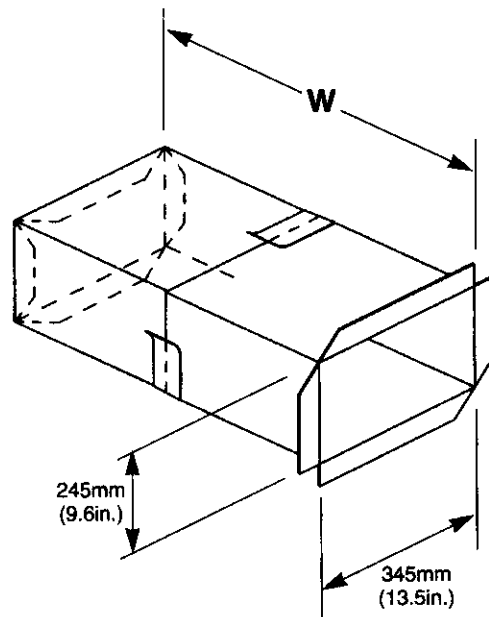

Fig. 15. Arrangement of balanced flue and terminal.

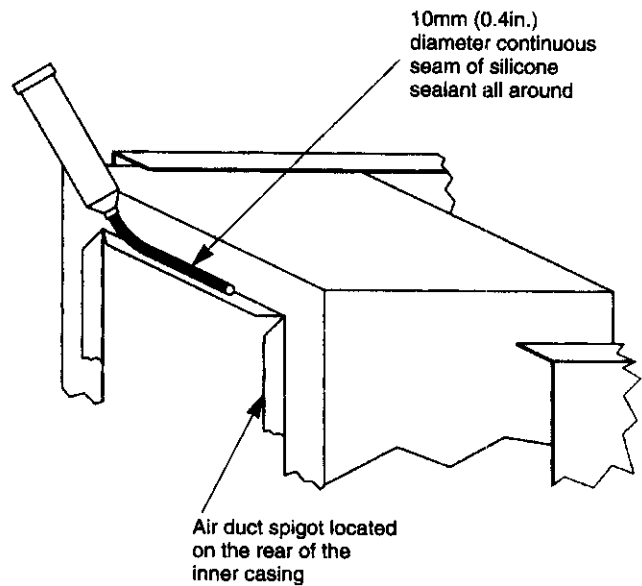
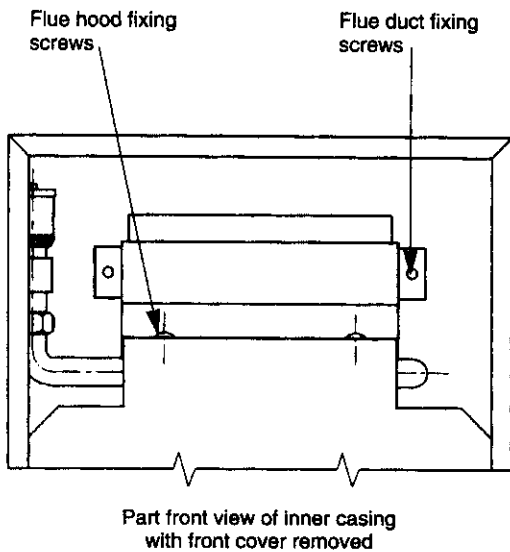
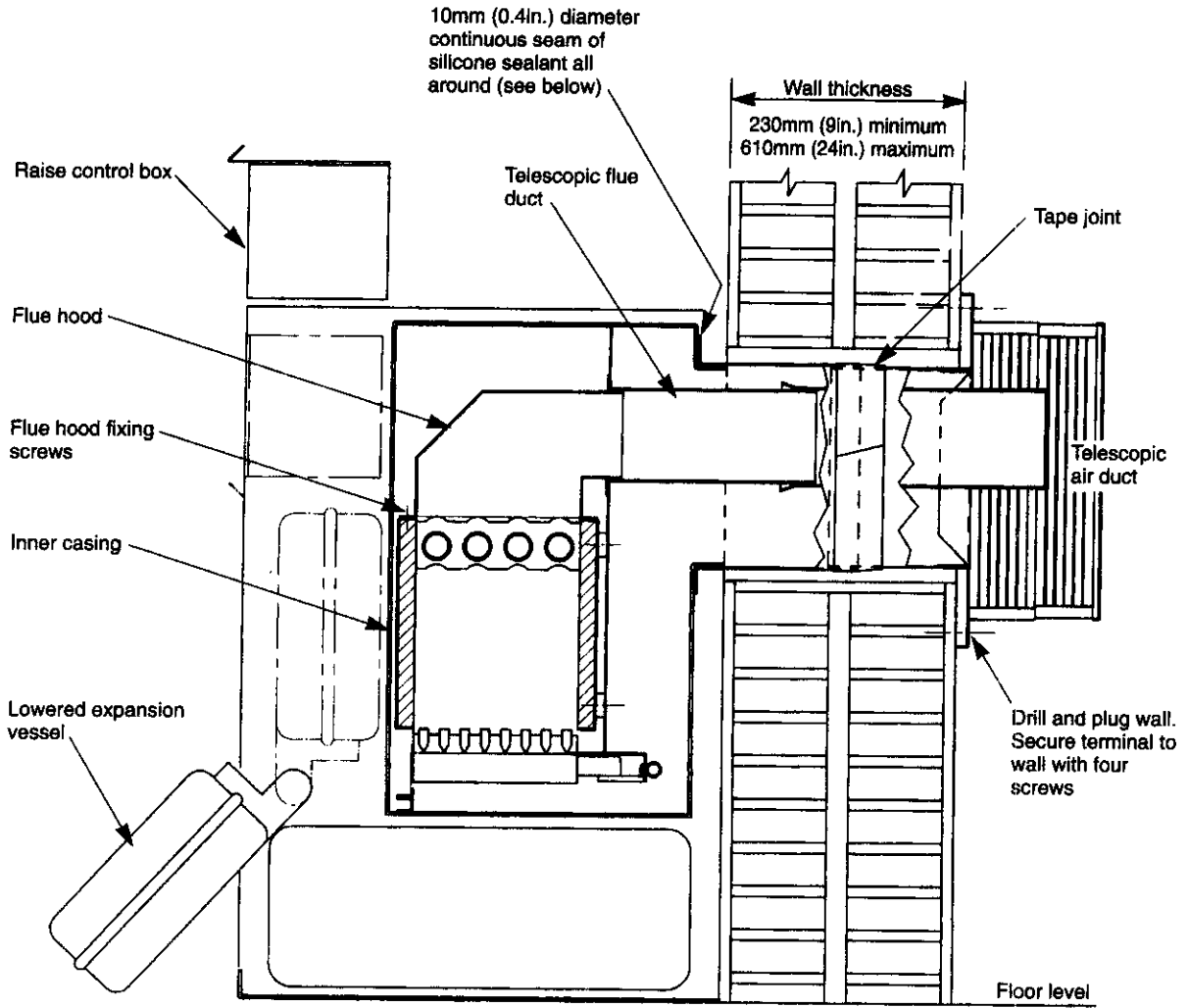

Fig. 16. Layout of components with expansion vessel in service position.

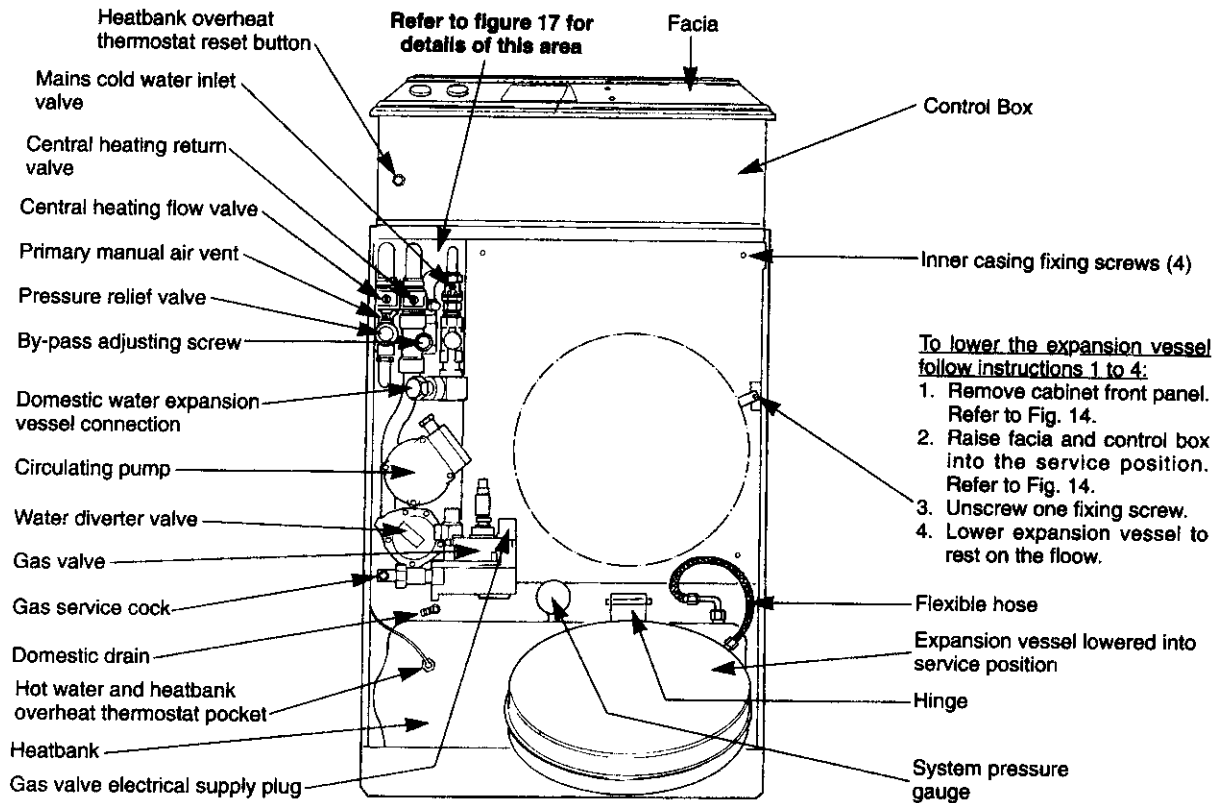

Fig. 17. Central heating flow and return valves, by-pass adjustment, pressure relief and manual air vent.

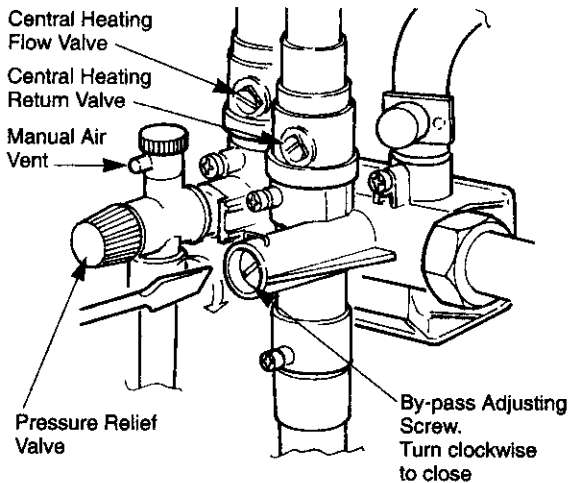

Fig. 18. Discharge pipe connection for sealed system.

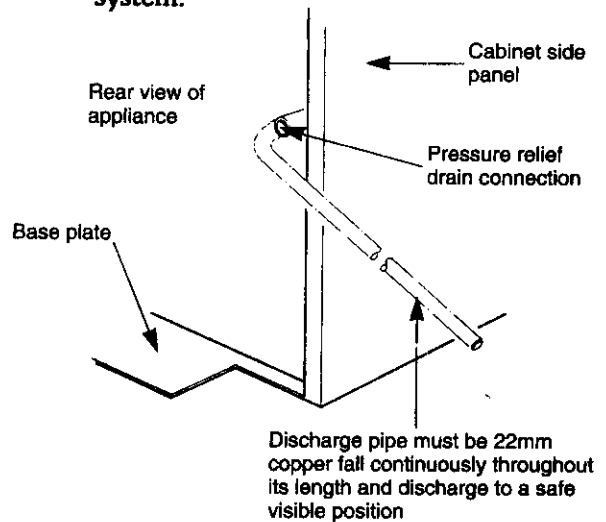

Fig. 19. Open vent position and pipework.

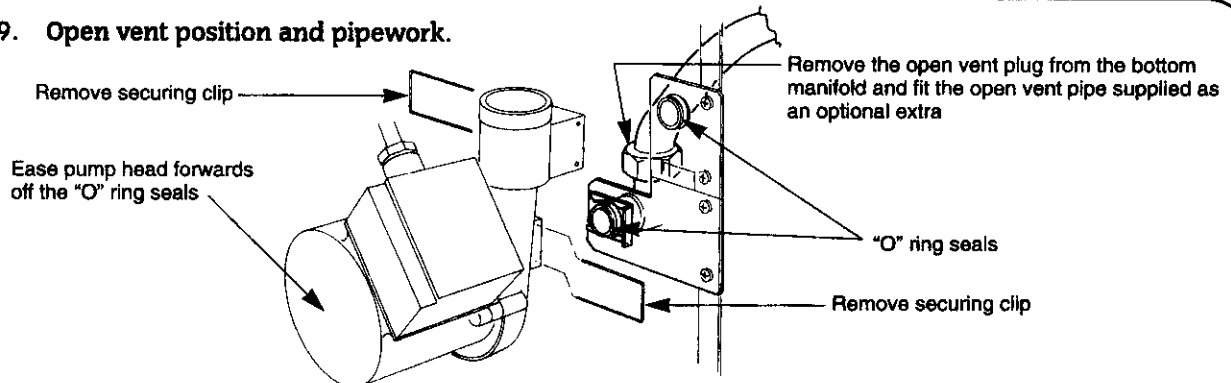

Fig. 20. Pilot burner assembly.

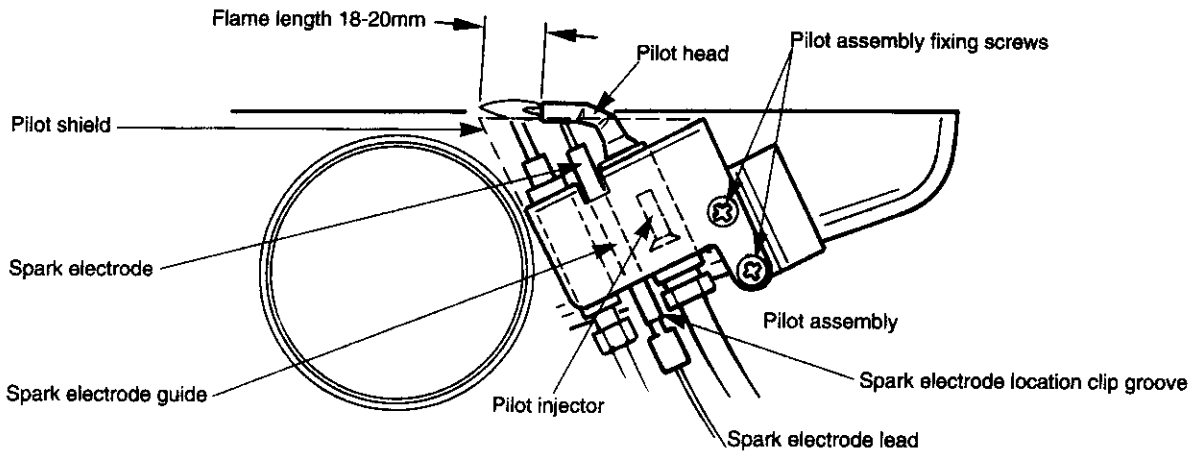
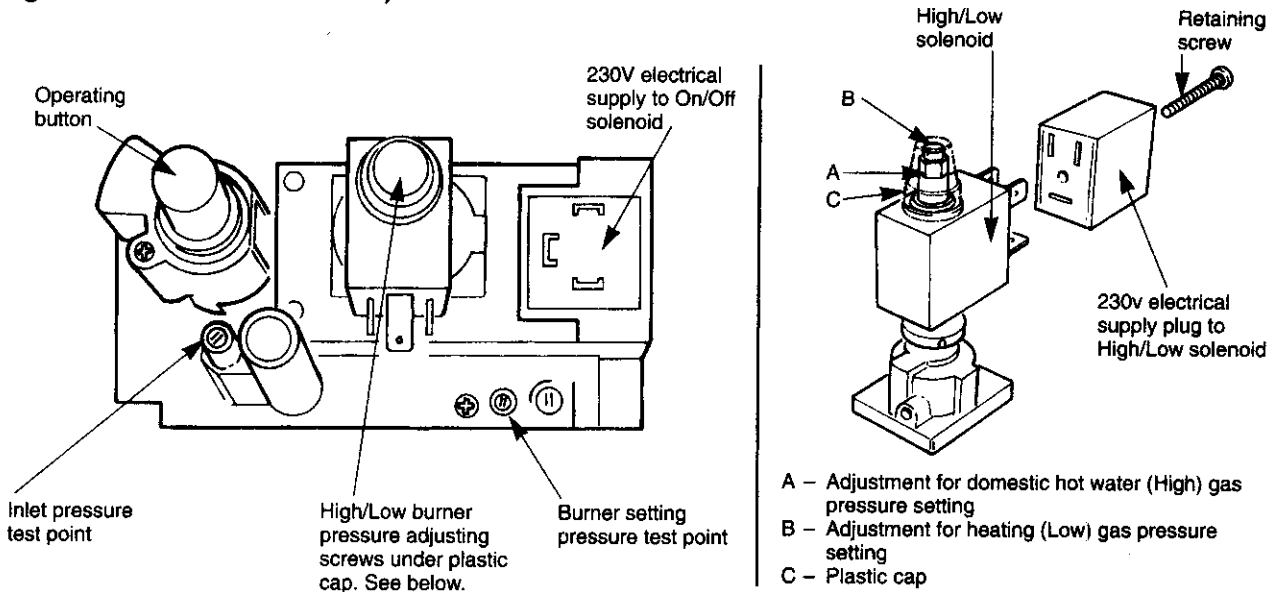

Fig. 21. Gas control valve adjustment.



12. Commissioning The Appliance

12.1 The appliance is despatched with the controls set to provide a maximum output for domestic hot water of 24 kW (82,000 Btu/h) and satisfy a central heating load of 15 kW (51,200 Btu/h).

The controls can be reset to increase or decrease the heat load capability from 8.8 kW (30,000 Btu/h) to 24 kW (82,000 Btu/h). Refer to Section 12.4, Appliance Operation (Central Heating Mode).

Domestic Hot Water System

Check that the mains water supply has been fully flushed out at installation.

Central Heating System

Check that the central heating system has been fully flushed out at installation.

Gas Service

The complete system, including the meter, shall be inspected and tested for soundness and purged as indicated in BS 6891.

12.2 APPLIANCE AND CENTRAL HEATING SYSTEM PREPARATION

If the cabinet front panel was replaced on final installation (Refer to Section 11.1) remove the panel before starting the commissioning procedure. See Fig. 12.

Check that the gas service and the electrical supply to the appliance are turned off. See Fig. 16.

Raise the facia and control box into the Service Position. Refer to Section 11.1 and Fig. 12.

Lower the expansion vessel into the Service Position and remove the inner casing front cover. See Fig. 16.

Check that all the water connections throughout the system are tight.

Open the system valves at the appliance. See Fig. 17.

Open all the radiator valves, fill the system and vent each radiator in turn.

Vent the heatbank from the manual air vent. See Fig. 17. The automatic air vent (fixed to the flow manifold) will vent the boiler section for sealed systems.

Do not replace the inner casing front cover until instructed in Section 12.4 Appliance Operation.

Check that the pressure relief valve operates by turning the knob anti-clockwise until it releases. Water should be expelled from the discharge pipe. See Fig. 17.

Sealed Systems Only

Set the Expansion Vessel Pressure.

The charge pressure of the expansion vessel (as supplied) is 0.5 bar, which is equivalent to a static head of 5 metres (17 ft). The charge pressure must not be less than the static head at the point of connection. See Fig. 16. A Schraider type tyre valve is fitted to the expansion vessel to allow the charge pressure to be increased if necessary.

Set the System Pressure.

Fill the system until the pressure gauge shows 2.5 bar (37 lb/ins²) and check for water soundness. Release water from the system using the pressure relief valve test knob until the System Design Pressure is obtained up to a maximum of 1.5 bar.

System Design Pressure in bar = Static Head of the System in bar + 0.3

Note: 1 bar is equivalent 10.2 metres (33.5 ft) of water

Set the movable pointer on the pressure gauge to coincide with the indicating pointer giving a permanent record of the set system pressure. See Fig. 16.

If the pressure indicated on the pressure gauge is greater than 2.5 bar when operating at the maximum central heating temperature, an extra expansion vessel must be fitted to the system as close to the appliance central heating return connection as possible.

The appliance (as despatched) can accommodate a system volume of about 104 litres. Refer to BS 7074 Part 1. If the system volume is in excess of that accommodated by the expansion vessel fitted to the appliance then an extra vessel must be fitted as close as possible to the central heating return connection of the appliance.

Any extra vessel fitted must be pressurised to the same figure as the integral vessel. If the expansion vessel fails then the specified replacement must be fitted.

12.3 PROGRAMMER

Any programmer fitted to the appliance should be set up at this stage following the instructions sent with the programmer.

12.4 APPLIANCE OPERATION

Check that the electrical supply to the appliance is off.

Turn the room thermostat (if fitted) to maximum.

Set the Operating Switch (or Programmer) to OFF.

In order to thoroughly vent the appliance and system the appliance may be operated without gas turned on as follows:

Switch on the electricity supply.

Set the Operating switch (or Programmer) to Heating and Water and the Hot Water thermostat to maximum. The pump will run but the main burner will not light. Primary water will circulate around the appliance.

Allow the appliance to operate in this condition for a few minutes before setting the Hot Water thermostat to the Off position.

Set the Heating thermostat to maximum and room thermostat (if fitted) to maximum. The water diverter will open to central heating and the appliance will operate as previously.

Primary water will now circulate around the central heating system. Allow the appliance to operate in this condition for a few minutes. Vent all radiators during this period until air is cleared from the system.

When the system has been vented sufficiently set the Heating thermostat to the Off position.

Note: The water diverter valve, in the de-energised condition, is always open to Hot Water. The controls give priority to reheating the heatbank following a demand for hot water. If the valve fails to open when energised to the central heating system, hot water will still be available.

The valve does not have a manually open position.

Set the Operating Switch (or Programmer) to OFF.

Switch off the electrical supply.

The appliance and central heating system should now be vented. Continue the appliance operation:

Turn on the gas supply. Check for gas soundness around the gas valve.

Light the pilot by pressing in the grey button on the gas valve and operating the red igniter button. When the pilot has lit continue to hold the grey button for a further 20 seconds and then release it slowly.

If the pilot does not stay alight, twist the gas valve button anti-clockwise. Wait for 3 minutes and repeat the operation until the pilot remains lit.

Test for gas soundness at the joint between the pilot pipe and the burner with leak detection fluid. See Fig. 20.

Observe the pilot flame. It should be about 20mm (3/4in) long and envelope the thermocouple tip. See Fig. 20.

Put the Operating Switch (or Programmer) to OFF and disconnect the electrical supply at the mains.

IMPORTANT: Replace the inner casing cover and reposition the pressure vessel. See Fig. 16.

Loosen the burner pressure test point screw and connect a pressure gauge. See Fig. 21.

Hot Water Mode

Set the Operating Switch (or Programmer) to Water. Turn the Hot Water thermostat to maximum. Turn the Heating thermostat to Off.

The boiler should light at a burner pressure of between 13.9 and 14.4 mbar (5.6-5.8 in wg). Allow the boiler to fire for at least 10 minutes before checking the gas pressure.

Note: It may be necessary to open a hot tap to maintain the boiler firing.

If the burner pressure is low check that the supply pressure at the gas valve is at least 19 mbar (7.6in wg). See Fig. 21.

Hot Water (High) Gas Pressure

The burner (High) pressure is factory set and is NOT adjustable in the Hot Water mode. If the gas supply pressure is correct but the correct burner pressure is not achieved, contact Worcester Heat Systems Service Department.

Check several times the main burner lights smoothly and goes out, by operating the Hot Water thermostat, before proceeding to check the Heating (Low) gas pressure.

Close the hot water tap (if necessary). The burner will be extinguished and the pump will continue running until the appliance has cooled to a preset temperature.

Set the Operating Switch (or Programmer) to Off.

Central Heating Mode

Check that all the radiator valves are open. Set the room thermostat, if fitted, to maximum and the Heating thermostat to maximum. Turn the Hot Water thermostat to Off.

Sealed Systems: Check the system is pressurised and set to the required pressure as indicated on the gauge. See Fig. 16.

Set the Operating Switch (or Programmer) to Heating and Water.

The boiler should light at a burner pressure of 5.7 mbar. (2.3 in wg).

Heating (Low) Gas Pressure

The burner (Low) pressure is factory preset to satisfy a central heating demand of up to 15 kW (51,200 Btu/hr). For different heating requirements the gas (Low) pressure must be adjusted to suit the installation.

The output to central heating is adjustable from a minimum of 8.8 kW (30,000 Btu/hr) to a maximum of 24 kW (82,000 Btu/hr). Refer to Section 3, Table 1, for Nominal Boiler Rating.

Allow the boiler to fire for at least 10 minutes before checking the (Low) gas pressure.

Ensure all the radiators are heating up evenly.

To adjust the Heating (Low) Gas Pressure:

- (a) Remove the grey plastic cover over the pressure adjustment screws on the gas valve. Place a small screwdriver in one of the slots and carefully lift the cap. See Fig. 21.
- (b) Using a small blade width screwdriver, turn the screw 'B' clockwise to increase and counter-clockwise to decrease pressure until the desired setting is achieved.
- (c) Operate the Heating thermostat several times to ensure the main burner ignites smoothly before checking that the gas valve switches from High to Low pressure correctly.
- (d) Using the Hot Water and Heating control thermostats, switch the appliance, from High to Low and back several times to ensure correct gas pressures. Replace the plastic cap 'C'
- (e) If the Heating (Low) Gas Pressure has been changed set the indicator arrow on the data plate to the new setting.

Balance the system so that the required temperature difference across the heating flow and return pipes is obtained. See Section 3, Table 3.

Adjust the by-pass valve until the same temperature difference is obtained. See Figs. 16 and 17. This should be carried out with only a single radiator operating.

If thermostatic radiator valves are fitted then one radiator should be left uncontrolled. The bypass valve should never be fully closed.

Set the room thermostat to minimum and check that the burner goes out.

Reset the room thermostat to maximum and the burner will re-light following the normal operating procedure.

Check for the proper ignition of the burner after a break in the gas supply.

Turn off the gas service cock and wait for 60 seconds. The main burner and pilot will go out. Carefully open the gas service cock and manually relight the pilot then following the normal sequence of operation check that the burner re-lights normally.

Put the Operating switch (or Programmer) to OFF. Switch off the gas service cock and the electrical supply to the appliance.

Drain the heating system whilst the appliance is still hot. Refer to Fig. 12. for the position of the appliance drain point.

Refill, vent and re-pressurise (sealed systems) as described previously.

Hot Water and Central Heating Mode

Turn on the electricity supply and open the gas supply cock to the appliance.

Relight the pilot using the same procedure described earlier in this section.

Set the Operating Switch (or Programmer) to Heating and Water. If a programmer is fitted set the Hot Water to Continuous or 24Hrs and the Heating to On.

Set the Hot Water thermostat to MAXIMUM. The main burner will relight and the boiler will heat the water stored in the heatbank. Once the heatbank has been satisfied the appliance will switch off.

Turn on any hot water tap to maximum. After a short period the burner will re-ignite. If hot water has not yet reached the tap, wait until it does, then turn the tap off. The boiler will fire until the heatbank has reheated and switch off.

Set the Operating Switch to Hot Water. If a programmer is fitted set the Hot Water to Continuous and the Heating Off. Repeat the previous hot water draw off

Set the Operating Switch to Heating and Hot Water. If a programmer is fitted set to Continuous or 24 Hrs and the Heating to ON. Set both appliance thermostats to maximum. The boiler will fire and commence to heat up the radiators. Allow to operate for 45 minutes, venting as necessary. Check for water soundness.

Note: From cold it will take about 12 minutes for the heatbank to be satisfied before the central heating system will receive heat.

IMPORTANT: The complete appliance must be checked for water leaks. Should any leaks be found they must be rectified before proceeding further.

Set the Operating Switch to OFF, or if a programmer is fitted, switch to OFF. Switch electrical supply off at the mains. Set both appliance thermostats to OFF.

Drain water from the appliance and the system from the drain points while the water is still hot.

Refill the appliance and system. Repeat commissioning operation under "Hot Water and Central Heating mode."

Check for correct operation of User's Controls including the room thermostat (if fitted) and leave set to customer's requirements.

12.5 COMPLETION OF COMMISSIONING

Disconnect the pressure gauge and tighten the test point screw.

Re-start the appliance and check for gas soundness around the test point screw.

Refit the expansion vessel and cabinet front panel. See Fig. 12 and 16.

If the appliance is being passed over to the User immediately refer to Section 13, Users Instructions and set the controls to the user's requirements.

If the appliance is to be left inoperative check that the Operating Switch or programmer is set to OFF. Turn the gas service cock to off and switch off the electricity supply.

If there is any possibility of the appliance and system being left inoperative during frosty conditions then drain the appliance and system.

For short inoperative periods leave the appliance under the control of a frost thermostat, if fitted, or operating continuously under the control of a room thermostat set at 6°C.

13. Instructions To The User

13.1 Tell the user how to operate the appliance and hand over the Users Instructions leaflet.

13.2 Tell the user what to do if the heating system is not to be used in frosty weather. Also tell the user that if the appliance is not to be used for long periods during frosty weather, the system must be drained and the gas and electricity supplies turned off.

13.3 Tell the user the Sealed System set pressure if applicable.

13.4 Tell the user of the importance of regular servicing. Worcester Heat Systems Ltd offer a comprehensive maintenance contract.

13.5 Set the system controls to the users requirements.

13.6 If an external programmer has been fitted which has a programmable hot water facility then instruct the user how to set up the programme.

14. Inspection And Servicing

To ensure continued efficient operation of the appliance it must be checked and serviced as necessary at regular intervals. The frequency of servicing will depend upon the particular installation conditions and usage, but once per year should generally be adequate. The extent of the service required by the appliance is determined by the operating condition of the appliance when tested by fully qualified engineers.

It is the law that any service work must be carried out by competent engineers such as British Gas or Corgi registered personnel.

14.1 PRE-SERVICE INSPECTION

Check that the flue terminal and the terminal guard, if fitted, are clear.

If the appliance is in a compartment check that the ventilation openings in the compartment door or walls are clear. Refer to Section 6, Air Supply.

Check the system and remake any joints or fittings which show signs of leakage. Refill, vent and re-pressurise sealed systems as described in Section 12. Commissioning.

Operate the appliance and the system taking note of any faults.

WARNING:

Disconnect the electrical supply at the mains and turn off the gas supply at the gas service cock on the appliance before servicing the appliance. See Fig. 16.

After completing the service always test for gas soundness as indicated in BS 6891.

14.2 DISMANTLE THE APPLIANCE

To carry out a full and comprehensive service of the appliance remove the following parts to gain access to the components which need to be checked or serviced.

(a) Cabinet Front Panel.

Lift off the top location and clear the lower return over the kick strip.

(b) Facia and Control Box.

Remove the cabinet front panel. Unscrew the two screws securing the facia to the outer edges of the cabinet, accessible under the facia. Ease the facia forwards on the slide rails until fully extended. Lift the facia and control box upwards through 90° into the Service Position. Lodge in the Service Position on the outer locations. See Figs. 12.

(c) Expansion Vessel.

Unscrew one screw securing the expansion vessel support bracket to the right hand side panel. Lower the vessel gently until resting on the floor. See Fig. 16.

(d) Inner Casing Cover.

Repeat operations a, b and c. Unscrew the four screws securing the cover to the inner casing and lift off. See Figs. 16 and 22.

(e) Flue Hood.

Repeat operations a, b, c and d. Unscrew the two screws locating the front of the flue hood to the combustion chamber cover. Ease the flue hood forwards about 15mm to clear the rear location. Remove the flue hood off the heat exchanger and clear of the inner casing. See Figs. 16 and 22.

(f) Combustion Chamber Cover.

Repeat operations a, b, c, d and e. Unscrew the four screws securing the combustion chamber cover and remove the cover. See Figs. 16 and 22.

(g) Burner.

Repeat operations a, b, c, d, e and f. Unscrew the two screws securing the pilot bracket to the burner. Unscrew the two screws securing the front of the burner to the burner bracket located inside the inner casing. Remove the burner by easing upwards and forwards off the main burner injector and clear of the pilot bracket. See Figs. 16 and 22.

(h) Pilot Bracket.

Repeat operations a, b, c, d, e and f. Unclip the spark electrode and withdraw it from the pilot bracket. Unscrew the two screws securing the pilot bracket to the burner bracket. Support the pilot bracket with a suitable tool. Unscrew the pilot pipe union nut and ease the pipe clear of the bracket. Unscrew the thermocouple retaining nut and carefully withdraw the thermocouple from the pilot bracket. Remove the pilot injector from the pilot bracket. See Figs. 16 and 22.

14.3 Servicing of Components.

Clean the Burner.

Brush the blade tops and mixing tube with a soft brush and check that all the flame ports are clear. Remove any blockages with a non-metallic brush.

Clean the Main Burner Injector.

Inspect the main burner injector located at the rear of the inner casing. Clean with a soft brush. Do not use a wire brush or anything likely to cause damage.

Clean the Pilot Bracket.

Brush with a soft brush. Clean the pilot injector by rinsing it in warm water. Check the condition of the electrode.

Clean the Gas to Water Heat Exchanger.

Cover the main burner injector and pilot bracket with a cloth. Clean the heat exchanger using a soft brush. Remove the deposits from the bottom of the combustion chamber. The heat exchanger is manufactured from copper take care not distort any of the fins.

Combustion Chamber Insulation.

Examine and replace any pads that are damaged.

Controls.

Remove any dust or deposits using a soft brush. Take care not to mishandle any component connections.

Note: Should any of the components be damaged they must be replaced before the service is completed. Refer to the appropriate item in Section 15 "Replacement of Parts."

After servicing, reassemble the appliance in the reverse order. Check that all components are in place and correctly fixed. See Fig. 16 and 22. Leave the cabinet front panel to be fitted after checking the operation of the appliance.

14.4 TEST THE APPLIANCE

On completion of the service and reassembly of the appliance, check for gas soundness and the correct operation of the appliance as described in Section 12. Commissioning. Refit the cabinet front panel and reset the controls to the users requirements.

15. Replacement Of Parts

WARNING: Switch off the electricity and gas supplies before replacing any components. After the replacement of any components check for gas soundness (where relevant) and carry out functional checks as described in Section 12.

15.1 COMPONENT ACCESS

To replace components:

It is necessary to remove one or more sections of the cabinet and cover plates within the appliance. Refer to Section 14.2 a, b, c and d.

To access the control box:

Place the facia and control box in the Service Position. Refer to Section 14.2, (b) and Fig. 12. Pull the two thermostat knobs clear of the facia. Unscrew two fixing screws at the top and two on the underside securing the facia to the control box. Ease the facia clear of the control box. Take care not to over stretch the capillary tubes or wiring. Ensure the facia is supported when out of the control box. See Fig. 12.

IMPORTANT:

The following components are secured to the appliance with clips, screws, union fittings or "O" ring seals to ensure the joints are water sound. See Fig. 16.

- Expansion Vessel.
- Circulating Pump.
- Water Diverter Valve.
- Water to Water Heat Exchanger.
- Gas to Water Heat Exchanger.
- Flow switch.
- Gas valve.
- Pressure relief valve.

Comprehensive gasket/ O-ring packs are available for the gas and water connections on the appliance.

Refer to Section 18, Short Parts List.

When replacing these components the connections must be fully entered so that the clips can pass completely into the locating groove. The clips must not be forced into place.

Fig. 22. Inner casing assembly.

(Pilot shield not shown for clarity)

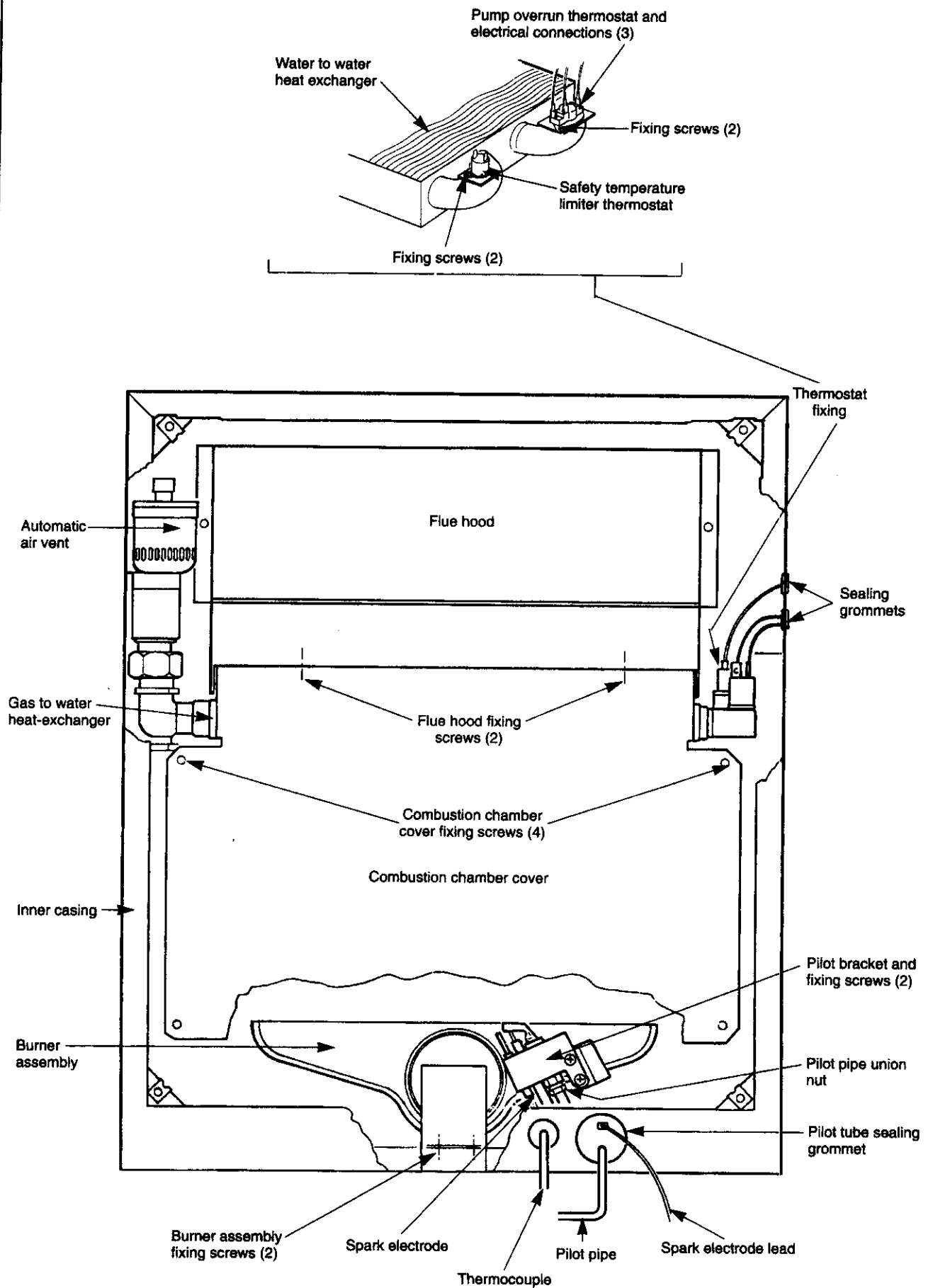

Any "O" ring which shows sign of damage must be replaced. The "O" rings can be lubricated with a suitable lubricant (i.e. silicon based grease or glycerin) which is non-reactive with the ethylene-propylene nitrile "O" rings.

15.2 DRAINING THE APPLIANCE

Check that the electricity supply to the appliance is turned off.

Remove the kick strip secured to the cabinet side panels and base plate with five screws. See Fig. 16.

Before removing any component holding water it is important that as much water as possible is drained from the appliance.

CAUTION: Some water will remain in the expansion vessel, pump, water diverter valve, water to water heat exchanger and gas to water heat exchanger. Extra care must be taken when removing these components.

Place a towel or cloth beneath the component to absorb the excess system water.

The water will be contaminated and any absorbent material used must be destroyed or washed thoroughly after any component has been replaced.

(a) Appliance Heatbank and Heating Circuit:

Turn off the central heating flow and return valves at the appliance using a flat blade screwdriver. See Fig. 17. Fit a tube to the drain tap located on the right hand side, front, of the heatbank and open the tap. See Figs. 1 and 12.

Note: The heatbank contains about 60 litres (13.5 gallons) of primary water sufficient time must be allowed to drain the heatbank. Close the drain tap when the flow has stopped.

(b) Appliance Hot Water Circuit:

Turn off the mains water supply valve at the appliance using a flat blade screwdriver. See Fig. 16. Fit a tube to the drain tap located on the left hand side of the gas valve. See Figs. 16 and 30.

Open the tap and drain the hot water circuit.

A quantity of water will remain in the water to water heat exchanger, extra care must be taken when removing this component.

15.3 COMPONENT REPLACEMENT

1. Automatic Air Vent. See Figs. 16, 22 and 23.

Check that the electricity supply to the appliance is turned off.

Remove the cabinet front panel, place the fascia and control box in the Service Position, lower the expansion vessel into the Service Position and remove the inner casing cover, as described in Section 14.2 a, b, c and d.

Drain the heating circuit as described in Section 15.2(a).

Unscrew the automatic air vent and discard. Fit the replacement assembly. Ensure the plastic cap is removed and discarded.

Open the valves, fill and re-pressurise the system as described in Section 12.2.

Ensure the joint is water tight. Reassemble the appliance in the reverse order.

2. Gas to Water Heat Exchanger. See Figs. 16, 22 and 23.

Check that the electricity supply to the appliance is turned off.

Remove the cabinet front panel, place the fascia and control box in the Service Position, lower the expansion vessel into the Service Position and remove the inner casing cover, as described in Section 14.2 a, b, c and d.

Drain the heating circuit as described in Section 15.2 (a).

Remove the flue hood and combustion chamber cover as described in Sections 14.2 e and f. Unscrew the retaining screws and remove the Safety Temperature Limiter Thermostat from the thermostat mounting plate as described in Section 15.3 - 12.

Ease the three electrical connections off the pump overrun thermostat. Remove the left hand fibre insulation pad from the combustion chamber. Remove the access cover in the left hand side of the combustion chamber held in position with one screw. Unscrew the front and rear heat exchanger union connections.

Lift the heat exchanger off the right hand side of the combustion chamber support and clear of the union connections. Remove the heat exchanger clear of the inner casing.

WARNING: There will be a small quantity of water remaining in the heat exchanger.

Follow the procedure as described in 15.2.

Unscrew the two screws securing the pump overrun thermostat to the heat exchanger. Retain the screws and pump overrun thermostat. Discard the heat exchanger.

Fit the pump overrun thermostat to the replacement heat exchanger using the original screws. Ensure a layer of heat sink compound is on the sensing head before fixing.

Fit the replacement heat exchanger in the reverse order using new fibre sealing washers. Ensure the washers are in place and the heat exchanger correctly aligned. See Fig. 23.

Tighten the union connections. Refit the access cover to the left hand side of the combustion chamber and replace the fibre insulation pad. Refit the combustion chamber cover. Refit the overheat thermostat with a layer of heat sink compound. Reconnect the electrical connections to the pump overrun thermostat. (Red lead to terminal No. 1, White lead to terminal No. 2 and Black lead to terminal No. 3). See Electrical diagram Fig. 8.

Reassemble the appliance in the reverse order.

Open the valves, fill and re-pressurise the system as described in Section 12.2

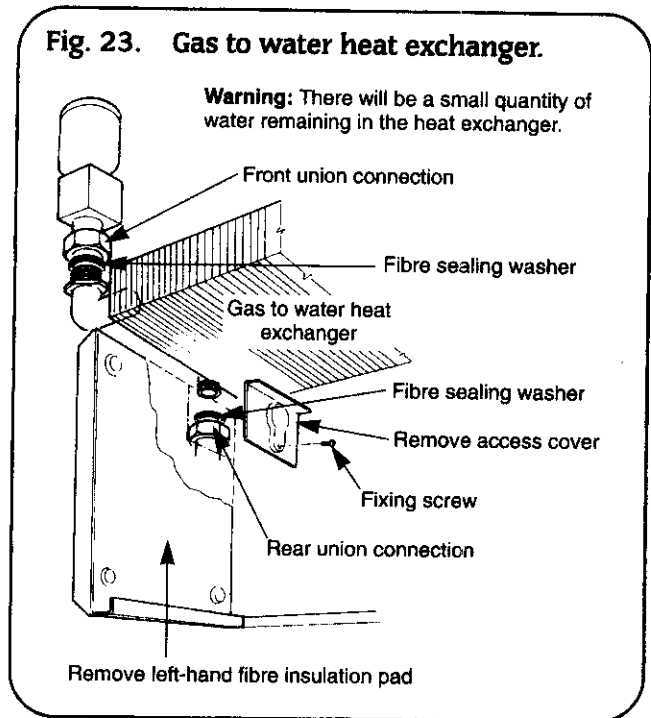

3. Combustion Chamber Insulation. See Figs. 16, 22 and 24.

Check that the electricity supply to the appliance is turned off.

Remove the cabinet front panel, place the fascia and control box in the Service Position, lower the expansion vessel into the Service Position and remove the inner casing cover, as described in Section 14.2 a, b, c and d.

Drain the heating circuit as described in Section 15.2 (a).

Remove the combustion chamber cover as described in Section 14.2 f.

Remove the gas to water heat exchanger as described in Section 15.3 - 2.

Remove the fibre insulation pads from the combustion chamber side, rear and front sections and discard.

Fit replacement fibre insulation pads in the reverse order.

Note: The fibre is fragile take care they are not damaged.

Ensure the insulation pad fitted to the combustion chamber cover has the pilot observation hole correctly aligned.

Reassemble the appliance in the reverse order.

Open the valves, fill and re-pressurise the system as described in Section 12.2

Fig. 24. Combustion chamber insulation.

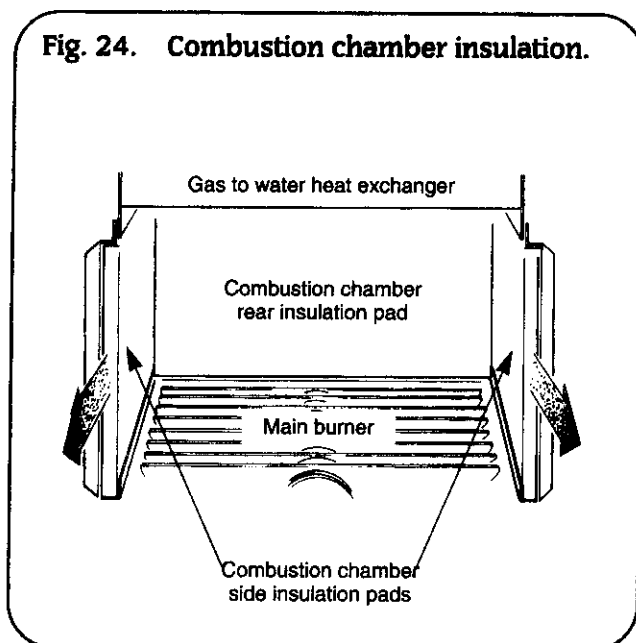

4. Main Burner. See Fig. 16, 20 and 22.

Check that the electricity supply to the appliance is turned off.

Remove the cabinet front panel, place the fascia and control box in the Service Position, lower the expansion vessel into the Service Position and remove the inner casing cover, as described in Section 14.2 a, b, c and d.

Remove the combustion chamber cover and main burner assembly as described in Sections 14.2 f and g. Discard the burner.

Fit a replacement main burner in the reverse order. Ensure the main burner is fitted correctly on the main burner injector located at the back of the inner casing. Reassemble the appliance in the reverse order.

5. Main Burner Injector. See Fig. 16, 22 and 25.

Check that the electricity supply to the appliance is turned off.

Remove the cabinet front panel, place the fascia and control box in the Service Position, lower the expansion vessel into the Service Position and remove the inner casing cover, as described in Section 14.2 a, b, c and d.

Remove the combustion chamber cover and main burner assembly as described in Sections 14.2 f and g.

Unscrew the brass injector at the rear of the inner casing and discard.

Fit the replacement injector in the reverse order. Thread sealing compound is not required. Reassemble the appliance in the reverse order.

Fig. 25. Main burner injector.

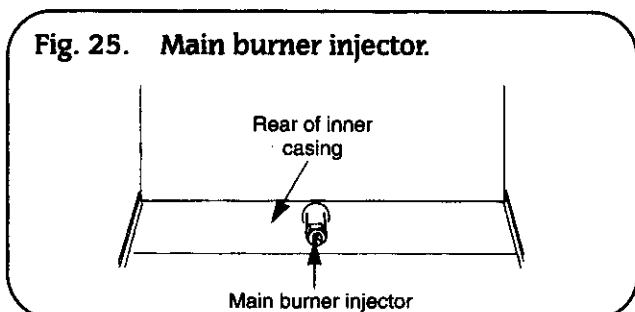

6. Thermocouple. See Figs. 16, 20, 22 and 26.

Check that the electricity supply to the appliance is turned off.

Remove the cabinet front panel, place the fascia and control box in the Service Position, lower the expansion vessel into the Service Position and remove the inner casing cover, as described in Section 14.2 a, b, c and d.

Unclip the spark electrode and withdraw from the pilot assembly.

Disconnect the thermocouple nut from the pilot bracket and ease the thermocouple from the assembly.

Disconnect the thermocouple nut from the right hand side of the gas valve and withdraw the thermocouple from the boiler.

Reassemble the appliance in the reverse order using a new thermocouple.

Avoid sharp bends in the thermocouple lead, ensuring that it follows the same route as the original.

7. Pilot Burner. See Figs. 16, 20, 22 and 26.

Check that the electricity supply to the appliance is turned off.

Remove the cabinet front panel, place the fascia and control box in the Service Position, lower the expansion vessel into the Service Position and remove the inner casing cover, as described in Section 14.2 a, b, c and d.

Remove the combustion chamber cover. See Section 14.2 f.

Unscrew the two screws securing the pilot burner to the main burner. Ease the pilot burner forwards sufficiently to allow a suitable tool to support it.

The spark electrode is held in position with a clip. Ease the clip backwards and remove the spark electrode and retain.

Disconnect the thermocouple nut from the pilot bracket and ease the thermocouple from the assembly.

Unscrew the union nut securing the pilot pipe and ease the pipe clear. Remove the pilot injector which is a push fit inside the pilot burner and retain.

Discard the pilot burner.

Fit a replacement pilot burner in the reverse order. Check the pilot burner settings and spark electrode gap are as shown in Fig. 26 and Section 12.4.

Reassemble the appliance in the reverse order.

8. Pilot Injector. See Figs. 16, 20, 22 and 26.

Check that the electricity supply to the appliance is turned off.

Remove the cabinet front panel, place the fascia and control box in the Service Position, lower the expansion vessel into the Service Position and remove the inner casing cover, as described in Section 14.2 a, b, c and d.

Remove the combustion chamber cover as described in Section 14.2 f.

Unscrew the two screws securing the pilot burner to the main burner. Ease the pilot burner forwards sufficiently to allow a suitable tool to support it.

The spark electrode is held in position with a clip. Ease the clip backwards and remove the spark electrode and retain.

Disconnect the thermocouple nut from the pilot bracket and ease the thermocouple from the assembly.

Unscrew the union nut securing the pilot pipe and ease the pipe clear. Remove the pilot injector which is a push fit inside the pilot burner and discard. Fit a replacement pilot injector in the reverse order. Check the pilot burner settings and spark gap are as shown in Fig. 26 and Section 12.4.

Reassemble the appliance in the reverse order.

9. Spark Electrode. See Figs. 16, 20, 22 and 26.

Check that the electricity supply to the appliance is turned off.

Remove the cabinet front panel, place the fascia and control box in the Service Position, lower the expansion vessel into the Service Position and remove the inner casing cover, as described in Section 14.2 a, b, c and d.

Remove the combustion chamber cover as described in Section 14.2 f.

Unscrew the two screws securing the pilot burner to the main burner. Ease the pilot burner forwards sufficiently to allow access.

The spark electrode is held in position with a clip. Ease the clip backwards and remove the spark electrode. Pull off the spark electrode cable and discard the spark electrode.

Fit a replacement spark electrode in the reverse order. Check the pilot burner settings and spark electrode gap is 4 to 5mm (0.8in), as shown in Fig. 26 and Section 12.4 Reassemble the appliance in the reverse order.

10. Spark Electrode Lead. See Figs. 16, 20, 22 and 26.

Check that the electricity supply to the appliance is turned off.

Remove the cabinet front panel, place the facia and control box in the Service Position, lower the expansion vessel into the Service Position and remove the inner casing cover, as described in Section 14.2 a, b, c and d.

Remove the combustion chamber cover as described in Section 14.2 f.

Unscrew the two screws securing the pilot burner to the main burner. Ease the pilot burner forwards sufficiently to allow access.

Carefully pull one end of the lead from the electrode and ease the other end off the tag on the piezo spark generator. Remove the lead from the appliance and discard.

Fit replacement lead in reverse order ensuring the inner casing is sealed correctly. Reassemble the appliance in the reverse order.

Check the pilot burner settings and spark electrode gap is 4 to 5mm (0.8in), as shown in Fig. 26 and Section 12.4. Reassemble the appliance in the reverse order.

Fig. 26. Pilot burner setting.

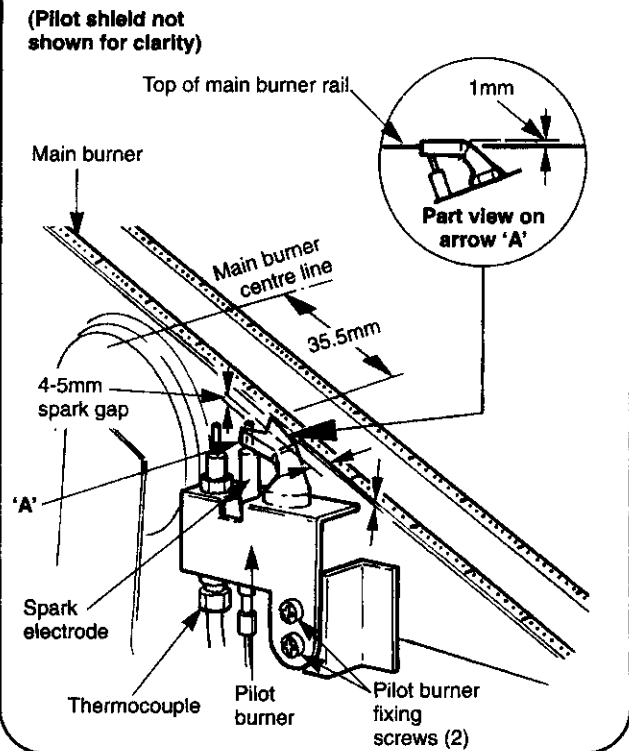

11. Piezo Spark Generator. See Figs. 16 and 22.

Remove the cabinet front panel, place the facia and control box in the Service Position and lower the expansion vessel into the Service Position as described in Section 14.2 a, b and c.

Ease the spark electrode lead from the tag on the piezo spark generator and remove the two screws attaching the generator to its mounting bracket. Retain the fixing screws.

Fit a new Piezo spark generator and reassemble the appliance in the reverse order.

12. Safety Temperature Limiter Thermostat. See Figs. 1, 16 and 22.

Check that the electricity supply to the appliance is turned off.

Remove the cabinet front panel, place the facia and control box in the Service Position, lower the expansion vessel into the Service Position and remove the inner casing cover, as described in Section 14.2 a, b, c and d.

Loosen the thermocouple connection to the gas valve and disengage the interrupter plate and thermostat lead. Unscrew the thermostat lead nut from the underside of the gas valve. Remove the sealing cover from the inner casing sealing the flying leads. Remove the two screws securing the thermostat to the mounting plate on the gas to water heat exchanger and retain. Carefully feed the flying leads through the hole in the side of the inner casing. Discard the thermostat.

Fit a new overheat thermostat in the reverse order and ensure the cover is replaced correctly and seals the inner casing.

Apply a smear of heat sink compound to the thermostat.

Reassemble the appliance in the reverse order.

13. Pump Overrun Thermostat. See Figs. 1, 16 and 22.

Check that the electricity supply to the appliance is turned off.

Remove the cabinet front panel, place the facia and control box in the Service Position, lower the expansion vessel into the Service Position and remove the inner casing cover, as described in Section 14.2 a, b, c and d.

Carefully pull off the three electrical connections to the pump overrun thermostat. Unscrew the two fixing screws securing the thermostat to the gas to water heat exchanger. Discard the pump overrun thermostat.

Fit a new pump overrun thermostat in the reverse order. Ensure a smear of heat sink compound is applied to the sensing head and the electrical connections are made correctly. (Red lead to terminal No. 1, White lead to terminal No. 2 and Black lead to terminal No. 3). See Electrical diagram Fig. 8.

Reassemble the appliance in the reverse order.

14. Hot Water Thermostat. See Figs. 1, 16, 27, 39 and 40.

Check that the electricity supply to the appliance is turned off.

Remove the cabinet front panel and place the facia and control box in the Service Position, as described in Section 14.2 a and b. Remove the facia as described in Section 15.1.

Remove the spring clip from the thermostat pocket located on the front left hand side of the heatbank.

Fig. 27. Hot water thermostat and heatbank overheat thermostat.

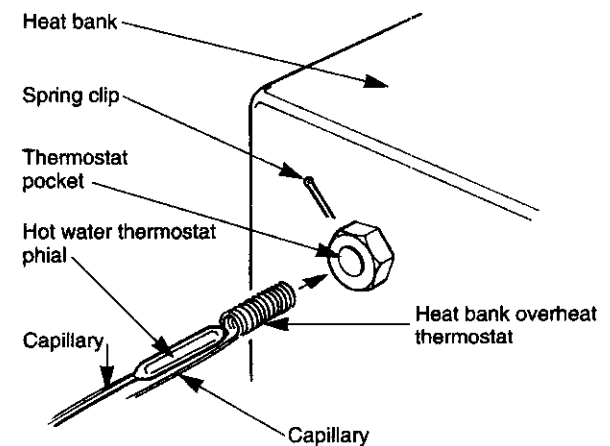

Note: There are two thermostat phials fitted in the pocket. The Hot Water thermostat phial is at the front of the pocket. To identify the phial follow the capillary tube from the thermostat body located inside the control box to the thermostat pocket. (Marked on the facia "Hot Water" thermostat).

Ease the phial out of the pocket and unclip the capillary from the left hand side of the cabinet panel.

Unscrew the two screws on the underside of the control box securing the mounting bracket to the control box. Ease the bracket out of the control box allowing the capillary tubes to feed through the slot in the rear of the control box.

Unscrew the left hand central clamping nut. Pull off the two electrical connections from the rear of the thermostat. Push the thermostat body back to disengage the spindle from the mounting bracket. Withdraw the thermostat threading the capillary through the slot in the rear of the control box and discard.

Fit a new thermostat and re-assemble in the reverse order. The capillary of the replacement thermostat must be uncoiled to assist its passage through the control box opening. Ensure the capillary is re-clipped to the left hand side panel, clear of any hot surfaces and without tight bends. Apply a smear of heat sink compound to the thermostat phial and replace the spring clip into the thermostat pocket.

Reassemble the appliance in the reverse order.

15. Heating Thermostat. See Figs. 1, 28, 39 and 40.

Check that the electricity supply to the appliance is turned off.

Remove the cabinet front panel, place the facia and control box in the Service Position, as described in Section 14.2 a and b. Remove the facia as described in Section 15.1.

Ease the spring wire retaining clip off the top location on the front of the top manifold assembly. Pull the retaining clip and capillary gently downwards out of the thermostat pocket located in the top manifold. Continue pulling gently downwards until the phial is clear of the thermostat pocket. Remove the spring wire retaining clip and retain. Unclip the capillary from the left hand side of the cabinet panel.

Unscrew the two screws on the underside of the control box securing the mounting bracket to the control box. Ease the bracket out of the control box allowing the capillary tubes to feed through the slot in the rear of the control box.

Unscrew the right hand central clamping nut. Pull off the two electrical connections from the rear of the thermostat. Push the thermostat body back to disengage the spindle from the mounting bracket. Withdraw the thermostat threading the capillary through the slot in the rear of the control box and discard.

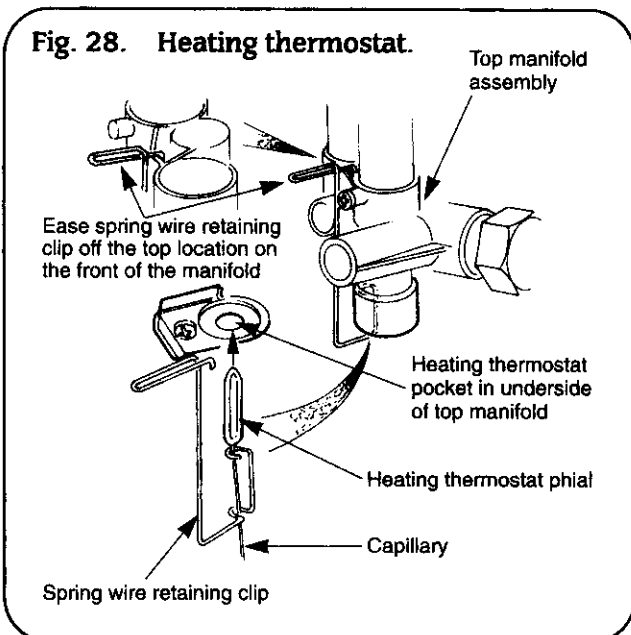

Fit a new thermostat and re-assemble in the reverse order. Apply a smear of heat sink compound to the thermostat phial. The capillary of the replacement thermostat must be uncoiled to assist its passage through the control box opening. Ensure the capillary is re-clipped to the left hand side panel, clear of any hot surfaces and without tight bends. The spring wire retaining clip must be re-located on the capillary and in the thermostat pocket.

Clip back into position on the top of the manifold assembly.

Reassemble the appliance in the reverse order.

16. Hot Water High Limit Thermostat. See Figs. 1, 8, 29, 38 and 39.

Check that the electricity supply to the appliance is turned off.

Remove the cabinet front panel, place the facia and control box in the Service Position, as described in Section 14.2 a and b. Remove the facia as described in Section 15.1.

Remove the flow switch and lay to one side. Refer to Section 15.3 - 30.

Unscrew the two M3 taptite screws holding the high limit thermostat to the hot water flow pipe and retain the screws.

Unplug the thermostat leads marked, X16 ("DHW Overheat"), from the control board and earth lead from the earthing bracket located in the control box.

Release the strain relief bush by compressing the loose section of the bush and carefully withdraw the leads from the control box. Remove the high limit thermostat and discard.

Fit a new high limit thermostat using the original fixing screws in the reverse order. Apply a smear of heat sink compound to the contact surface. Ensure the leads are connected to the control board and earthing bracket correctly and the strain relief bush is replaced. Reassemble the appliance in the reverse order.

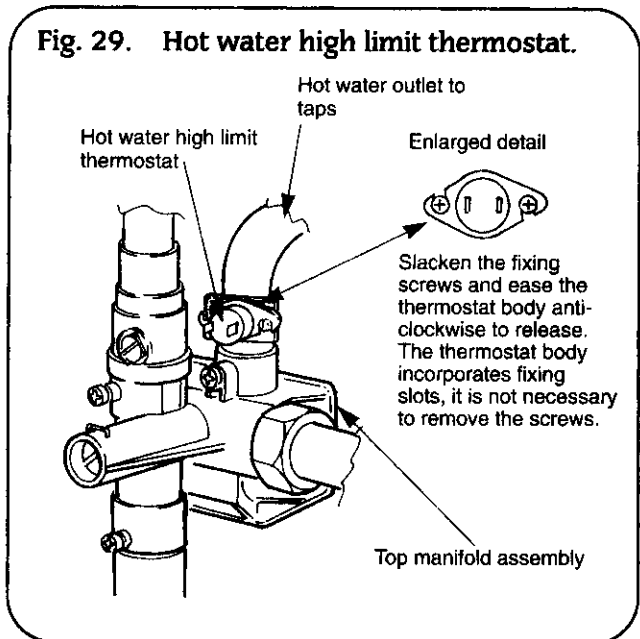

17. Heat Bank Overheat Thermostat. See Figs. 1, 16, 27, 39 and 40.

Check that the electricity supply to the appliance is turned off.

Remove the cabinet front panel and place the facia and control box in the Service Position, as described in Section 14.2 a and b. Remove the facia as described in Section 15.1.

Remove the spring clip from the thermostat pocket located on the front left hand side of the heatbank.

Note: There are two thermostat phials fitted in the pocket. The Heat Bank Overheat Thermostat phial is located at the rear of the pocket. To identify the phial follow the capillary from the thermostat body inside the control box to the thermostat pocket.

Ease the first phial clear of the pocket and place to one side. Ease the overheat thermostat phial clear of the pocket and unclip the capillary from the left hand side of the cabinet panel.

Unscrew the two screws on the underside of the control box securing the mounting bracket holding the Hot Water and Heating thermostats to the control box. To access the Heat Bank Overheat thermostat ease this bracket sufficiently clear of the control box allowing the capillary tubes to feed through the slot in the rear of the control box.

Pull off the two electrical connections from the rear of the thermostat. Unscrew the central clamping nut. Withdraw the overheat thermostat and thread the capillary through the hole in the left hand side of the control box. Discard the thermostat.

Fit a new thermostat and re-assemble in the reverse order. The capillary of the replacement thermostat must be uncoiled to assist its passage through the hole in the control box. Ensure the capillary is re-clipped to the left hand side panel, clear of any hot surfaces and without tight bends. The spring clip must be replaced into the thermostat pocket.

Ensure the electrical connections are made to the terminals inside the control box, polarity is not important. Apply a smear of heat sink compound to the thermostat phial.

Reassemble the appliance in the reverse order.

18. Gas Valve. See Figs. 16, 21 and 30.

Check that the electricity supply to the appliance is turned off.

Remove the cabinet front panel, place the facia and control box in the Service Position and lower the expansion vessel into the Service Position as described in Section 14.2 a, b and c.

Turn off the gas supply at the service cock.

Disconnect the pilot pipe at the gas valve. Unscrew the bracket supporting the domestic drain from the left hand side of the gas valve. Retain bracket and screw.

Disconnect the thermocouple from the gas valve and disengage the interrupter and thermostat lead. Unscrew the thermostat lead nut from the underside of the gas valve.

Unscrew the four M4 extended hexagon headed screws securing the outlet flange connection to the side of the gas valve. Unscrew the inlet gas union at the gas service cock. Support the valve and unscrew the retaining screws from the solenoid electrical connection plugs and pull each plug off its respective set of terminals.

Note: The plugs are dissimilar and not inter-changeable.

Fig. 30. Gas valve.

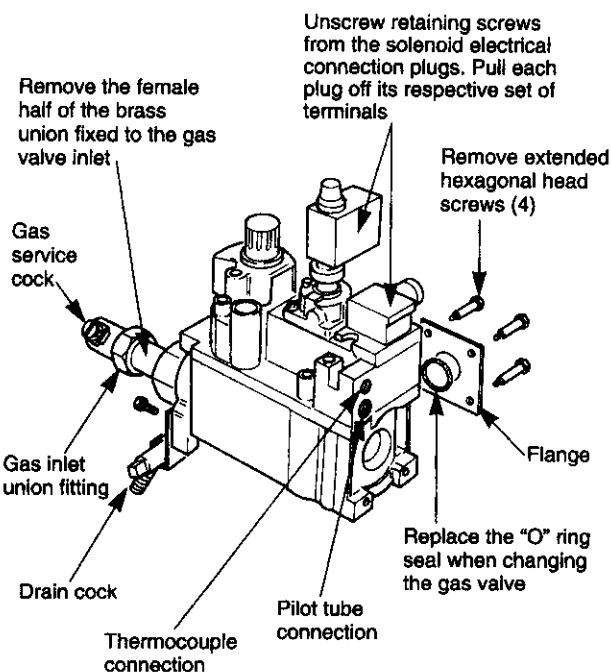

Remove the gas valve and flange sealing washer clear of the appliance.

Remove the female half of the brass union connector fixed to the gas valve inlet. Discard the gas valve and sealing washer.

Using an approved jointing compound complying with BS 5292 fit the female half of the brass union to the replacement gas valve inlet.

Fit the replacement gas valve in the reverse order ensuring the flange washer is renewed.

Reassemble the appliance in reverse order.

Turn on the gas supply at the service cock and check for gas soundness.

Re-commission the appliance and check the burner setting pressure. Refer to Section 12 - Commissioning.

19. Pilot Filter.

If problems are experienced with the pilot filter fit a replacement gas valve as described in Section 15.3 - 18.

20. Circulating Pump. See Figs. 16 and 31.

Check that the electricity supply to the appliance is turned off.

Remove the cabinet front panel, place the facia and control box in the Service Position and lower the expansion vessel into the Service Position, as described in Section 14.2 a, b and c.

Drain the heating circuit as described in Section 15.2 a.

Remove the pump electrical cover and disconnect the electrical connections. Release the cable clamp and remove the cable.

Withdraw the two securing clips from the pump body. Ease the pump forwards about 10mm off the "O" ring seals and remove from the appliance.

WARNING: There will be a small quantity of water remaining in the pump and pipework.

Follow the procedure as described in 15.2

Discard the pump and "O" ring seals.

Fig. 31. Circulating pump.

Warning: There will be a small quantity of water remaining in the pump and pipework

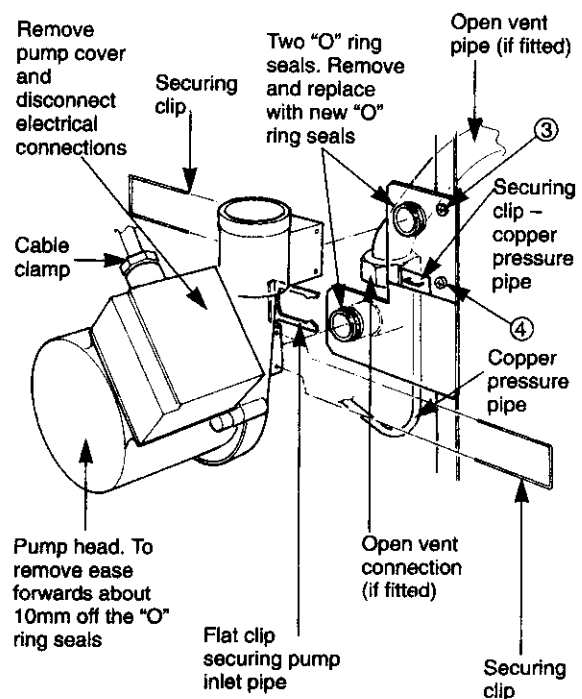

Fit new "O" ring seals. Fit a replacement pump in the reverse order taking care to ensure the securing clips are properly entered into the slots and not scoring the O-rings on entry. A smear of lubricant on each O-ring will ease the re-assembly. Check the pump head is set to maximum.

The pump head is a Grundfos 15-60. A replacement head may be transferred to the special body. Take care not to mark the mating surfaces.

Reconnect the cable and refit the cable clamp.

Open the valves, fill and re-pressurise the system as described in Section 12.2. Reassemble the appliance in the reverse order.

21. Water Diverter Valve. See Figs. 8, 16, 31 and 32.

Check that the electricity supply to the appliance is turned off.

Remove the cabinet front panel, place the facia and control box in the Service Position and lower the expansion vessel into the Service Position, as described in Section 14.2 a, b and c. Remove the facia as described in Section 15.1

Drain the heating circuit as described in Section 15.2 a.

Remove the circulating pump as described in Section 15.3 - 20.

Note: It is not necessary to disconnect the electrical cable. The cable length is sufficient to allow the pump head to rest on top of the appliance. Do not allow the pump head to be suspended by the cable. Secure the pump head.

Pull off the Molex plug marked X7 "Diverter Valve" from the control board located in the control box. Release the strain relief bush by compressing the loose section of the bush and carefully withdraw the lead from the control box.

Using a pair of long nose pliers, remove the two clips securing the 6mm copper pressure pipe, to the top left hand corner of the valve and pump connection. Retain the clips. Ease the pressure pipe out of the connections and clear of the appliance.

Retain the pressure pipe.

Unscrew the four fixing screws securing the water diverter valve to the bottom manifold. The bottom right hand screw is

accessible using a "chubby" type screwdriver. Remove the water diverter valve clear of the appliance. Discard the valve and "O" ring seals. Retain the fixing screws.

WARNING. There will be a small quantity of water remaining in the valve and lower manifold. Follow the procedure as described in Section 15.2.

Note: Three new "O" ring seals are provided with the replacement valve. Two of the "O" rings are identical in diameter and cross - section and are required for the outer ports. The third "O" ring is smaller in diameter and cross-section and will seal the centre port.

IMPORTANT: Fit the two larger diameter "O" rings into the outer locations on the replacement valve. Fit the smaller diameter "O" ring over the centre spigot on the bottom manifold. Ensure the "O" ring is located correctly against the shoulder on the centre spigot.

Fit the replacement valve in reverse order ensure the four fixing screws are correctly engaged. Replace the "O" ring seals and refit the pressure pipe. Ensure the securing clips are fully engaged in the locating holes.

Reconnect the electric cable to the control board and replace the strain relief bush. Replace the circulating pump as described in Section 15.3 - 20.

Open the valves, fill and re-pressurise the system as described in Section 12.2. Reassemble the appliance in the reverse order.

22. Water to Water Heat Exchanger. See Figs. 16, 28, 29, 31, 32, 33, 34, 35, 37 and 38.

Check that the electricity supply to the appliance is turned off.

Remove the cabinet front panel, place the facia and control box in the Service Position and lower the expansion vessel into the Service Position, as described in Section 14.2 a, b and c.

Drain the heating and hot water circuit as described in Section 15.2.

Fig. 32. Water diverter valve.

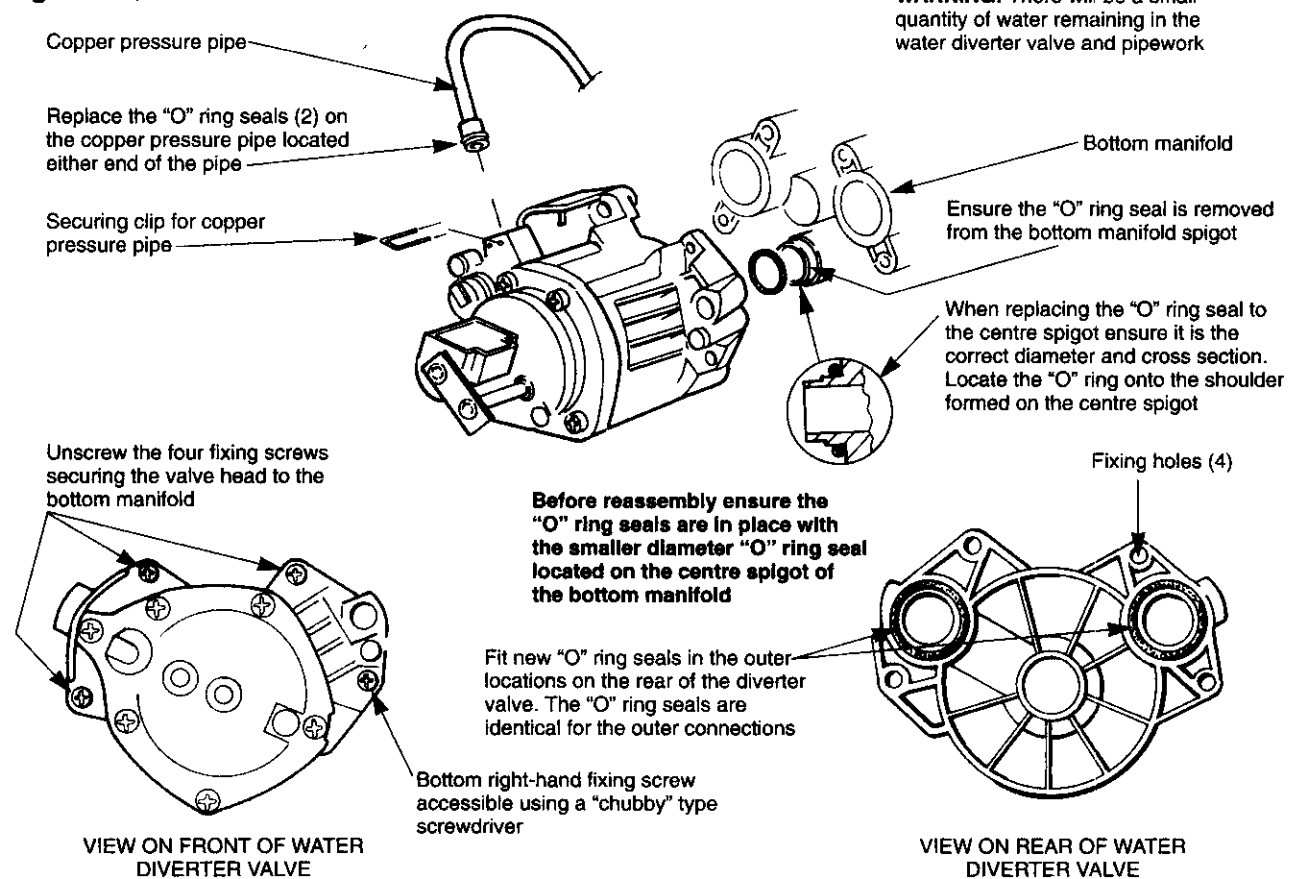

WARNING: The weight of the water to water heat exchanger is 2 kg. approx. A quantity of water will remain in the heat exchanger and pipework. Follow the procedure as described in 15.2

Remove the circulating pump as described in Section 15.3 - 20.

Remove the water diverter valve as described in Section 15.3 - 21.

Note:

- (i) It is not necessary to disconnect the electrical cable from these components. The length of cable is sufficient to allow them to rest on top of the appliance cabinet. Do not allow them to be suspended by the cable. Secure the pump head and diverter valve.
- (ii) Unless otherwise stated all water joints are sealed with "O" rings. To disconnect twist the pipe and/or ease the joint apart. When re-connecting the joint a new "O" ring must be fitted. Silicone grease must be applied to the "O" ring.

Remove the pressure relief valve and manual air vent as described in Section 15.3- 27 and retain.

Unscrew locating screw No. 1 in the bottom manifold two full turns.

Unscrew the flat faced union fitting below the flow switch and remove the sealing washer and discard. Move the cold water inlet pipe to the left to clear the flow switch. Ease the pipe upwards, 10mm approx. and remove from the bottom manifold. Retain the pipe.

Unscrew the union fitting below the cold water inlet valve and remove the flow switch and water filter assembly.

Place the flow switch and water filter assembly on top of the appliance cabinet and secure.

Unscrew locating screw No. 2 in the top manifold two full turns. Ease the heating return pipe downwards 10mm approx. into the slip joint in the bottom manifold. Move the pipe to the left to clear the top manifold. Ease the pipe upwards 10mm approx. and remove the pipe from the bottom manifold. Retain the pipe.

Remove the heating control thermostat phial as described in Section 15.3 - 15. Place the phial to one side.

If the appliance is fitted to an open vent system unscrew the open vent union connection and remove the washer.

Remove the flat clip securing the pump inlet pipe to pump support plate. Retain the clip.

Remove the two screws Nos. 3 and 4 securing the pump inlet pipe support plate and remove the plate. Unscrew locating screw No. 5 two full turns. Ease the pump inlet pipe upwards 10mm approx. and remove from the bottom manifold. Retain the pipe, plate and screws.

To access the water to water heat exchanger the top manifold must first be removed:

Unscrew locating screws Nos. 6, 7 and 8 two full turns. Unscrew and remove screws Nos. 9 and 10 securing the manifold to the water to water heat exchanger support bracket. Retain the screws.

Unscrew the flat faced union securing the manifold to the inner casing pipework. Remove the sealing washer and discard.

Ease the manifold assembly downwards, 10mm approx., until clear of the heating flow and return pipes and hot water outlet pipe.

Remove the manifold clear of the appliance and retain.

Unscrew locating screws Nos. 11 and 12 two full turns. Unscrew and remove screws Nos. 13 and 14 securing the bottom manifold to the water to water heat exchanger support bracket. Retain the screws.

Unscrew the bracket supporting the domestic drain from the left hand side of the gas valve. Using long nose pliers remove the clip securing the drain pipe to the bottom manifold. Ease the drain pipe downwards out of the manifold and remove. Retain the clip, screw, bracket and drain pipe.

Ease the bottom manifold and water to water heat exchanger upwards 10mm approx. until clear of the heat bank flow and return pipes.

Note: It may be necessary to push down on the flow and return pipes to release the "O" ring fittings. Before entering the heat bank the flow and return pipes are fitted into slip joints. The joints are sealed with "O" rings and allow some movement forwards or backwards when removing the bottom manifold and water to water heat exchanger.

Ease the water to water heat exchanger and bottom manifold from the support bracket and clear of the appliance.

Release screw No. 15 and remove the bottom manifold off the locations on the water to water heat exchanger. Discard the heat exchanger and retain the fixing screw.

Remove the two "O" ring seals from the rear of each manifold and discard.

IMPORTANT: Two new "O" ring seals must be fitted to the rear of each manifold.

If the flow and return pipes to the heat bank have been disturbed when removing the water to water heat exchanger the "O" ring seals must be replaced :

Ease the heat bank flow pipe out of the front slip joint and return pipe out of the rear slip joint and clear of the push in elbows.

Remove and discard the "O" ring seals from each pipe. Replace with new "O" ring seals.

Pull out the flat clip from the front push in elbow and remove the elbow. Retain the clip and push in elbow.

To release the rear elbow reach under the water to water heat exchanger bracket and push in fully the flat plate clamp mechanism. Remove the rear push in elbow and retain. Remove and discard the elbow "O" ring seals. Replace with new "O" ring seals.

Re-assemble the rear and front push in elbows. Ensure the rear clamp mechanism is engaged and fully pulled into the location. Engage the front flat clip into the slot correctly.

Re-assemble the flow and return pipes into the slip joints. The pipe lengths are not identical, the longest pipe is rear/ return pipe.

Re assemble the bottom manifold to the replacement water to water heat exchanger. Ensure the heat exchanger is located correctly with the internally threaded boss fitting through the fixing hole in the manifold and the raised section on the manifold port fitting into the bottom right hand port on the heat exchanger.

Replace screw No. 15 and tighten.

Fit the replacement water to water heat exchanger and bottom manifold assembly into the support bracket. Ensure the heat bank flow and return connections are fully engaged. Secure the assembly to the support bracket with screw Nos. 13 and 14. Fully tighten the screws fixing the "O" rings Nos. 11 and 12.

Re-assemble the top manifold in the reverse order.

Ensure the heating flow and heating return and hot water pipes are fully engaged.

Ensure a new sealing washer and "O" ring is fitted when re-connecting the union securing the top manifold to the inner casing pipework. Replace the manifold top fixing screws Nos. 9 and 10. Tighten screws Nos. 6, 7 and 8 and manifold union fitting.

Re-assemble the pump outlet pipe and re-fit the pump support plate. Ensure the flat clip is re-located. Re-connect the open vent pipe (if applicable).

Ensure a new sealing washer is fitted.

Replace the heating thermostat phial and wire clip.

Re-assemble the heating return pipe using the slip joint in the bottom manifold to manoeuvre the pipe into position.

Re-assemble the cold water inlet pipe and flow switch ensure the sealing washer is renewed. Re-connect the union fitting to the cold water inlet valve.

Re-assemble the pressure relief valve ensuring the securing clip is replaced.

Fig. 33. Water to water heat exchanger.

Note: Screw Nos. ① ②, ⑤ ⑥ ⑦ ⑧, ⑪ ⑫ unscrew two full turns – **Do not remove.**
Screw Nos. ③ ④ (Refer to Fig. 31) ⑨ ⑩ ⑬ ⑭ ⑮ remove and retain.

Warning: There will be a small quantity of water remaining in the pipework and water-to-water heat exchanger.

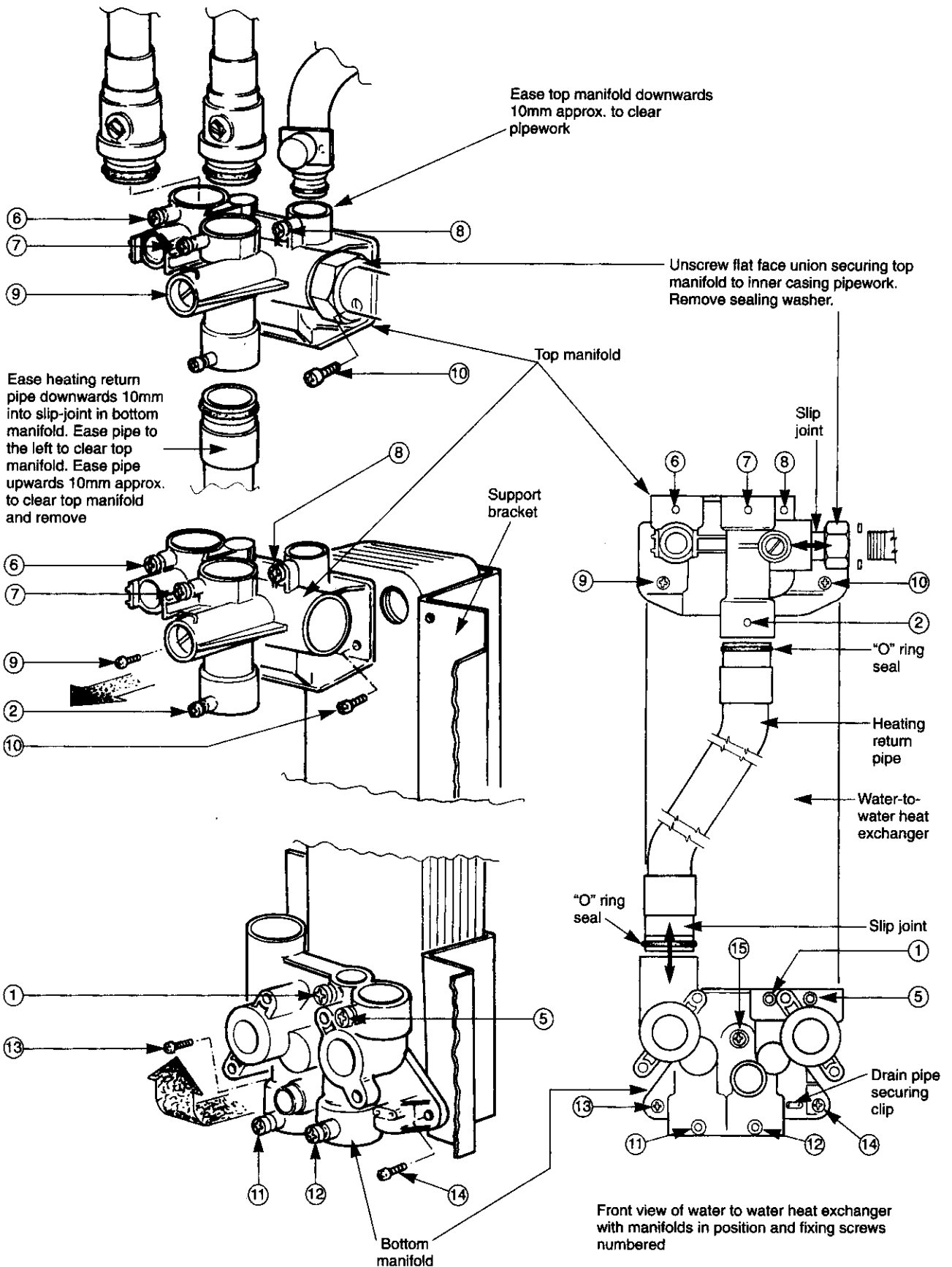

Fig. 34. Water to water heat exchanger.

WARNING: There will be a small quantity of water remaining in the pipework and water-to-water heat exchanger

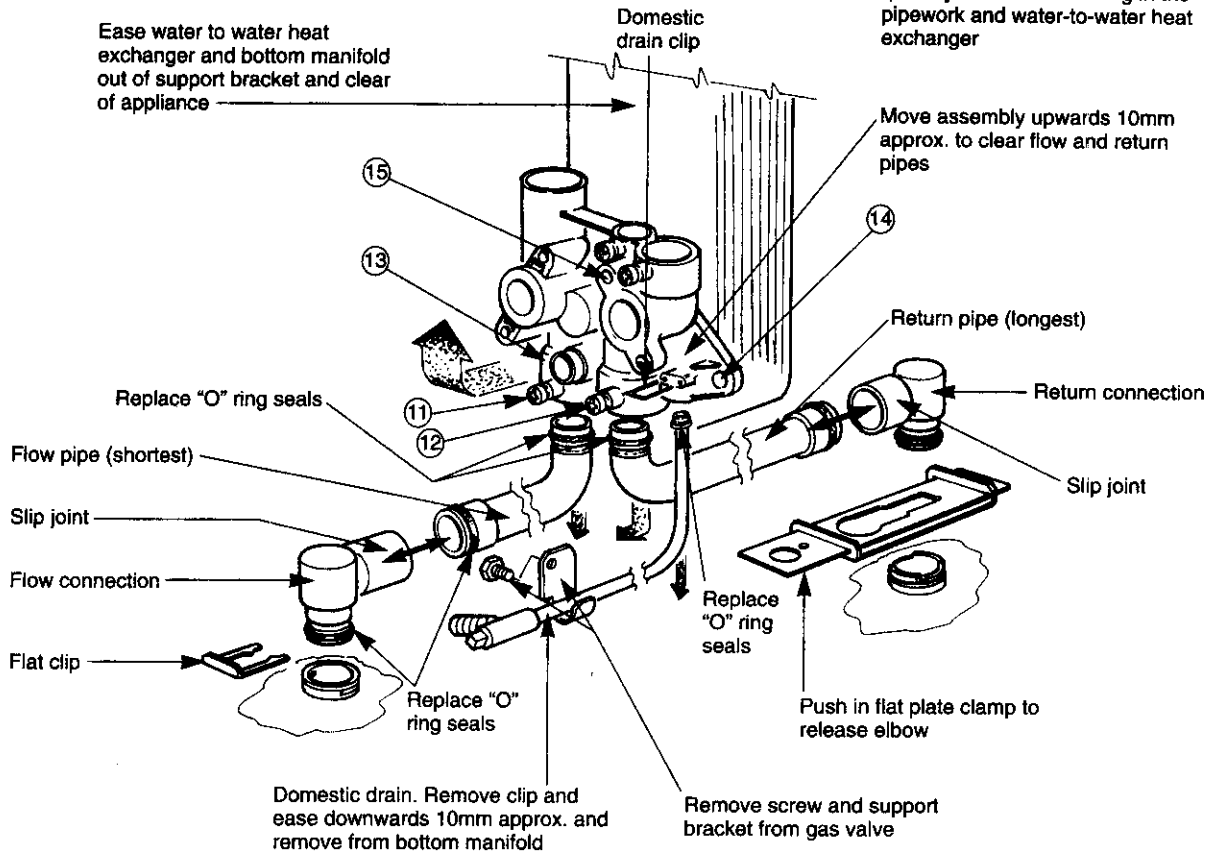
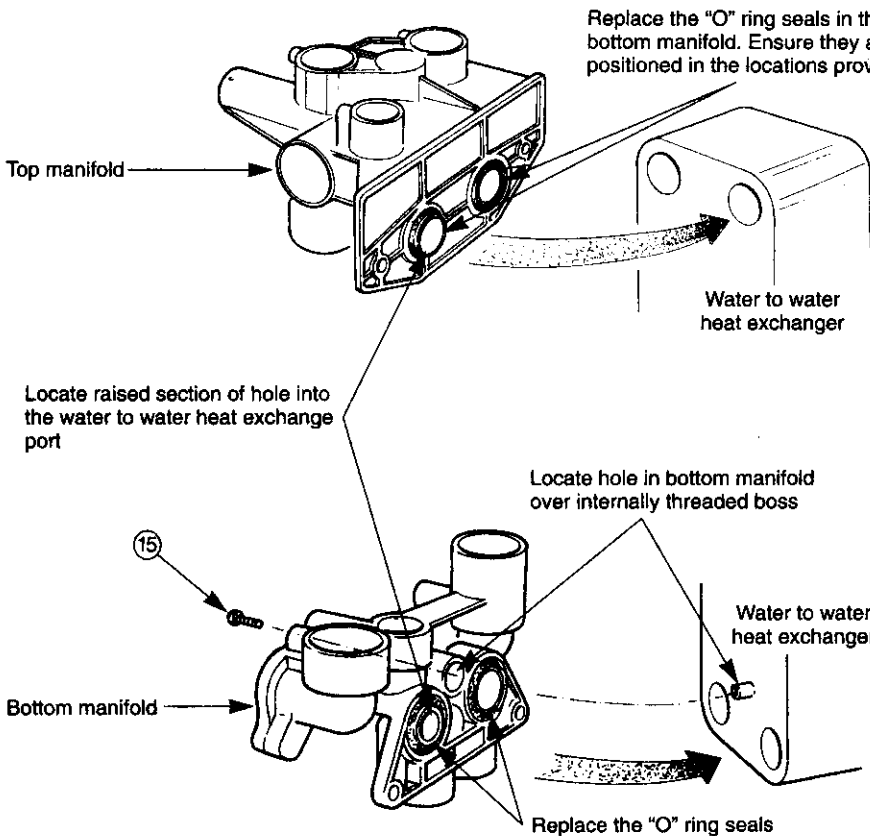

Fig. 35. Replacing the "O" ring seals in top and bottom manifolds.



IMPORTANT:

Before the water diverter valve is re-assembled ensure the domestic drain pipe and clip are fitted to the bottom manifold. Refer to Fig. 48.

Before tightening screws ① ② ⑤ ⑥ ⑦ ⑧ ⑪ ⑫ ensure the "O" ring seals are fully pushed into their respective housing.

Ensure screws ⑬ and ⑭, securing the bottom manifold to the support bracket, are fully tightened.

Ensure screws ⑨ and ⑩, securing the top manifold to the support bracket, are fully tightened.

Re-assemble the domestic drain pipe re-locate the securing clip and bracket.

Before continuing ensure screws 1, 2, 5, 6, 7, 8, 11 and 12 are tightened.

The "O" ring seals must be pushed fully into the housing.

Re-assemble the water diverter valve. Re-assemble the 6mm diameter pressure pipe to the pump inlet pipe and diverter valve. Ensure the securing clips are replaced.

Re-assemble the circulating pump ensure the securing clips are re-placed.

Open the valves, fill and re-pressurise the system as described in Section 12.2. Reassemble the appliance in the reverse order.

23. Water to Water Heat Exchanger Top Manifold.

See Figs. 16, 28, 33, 35, 37 and 39.

Check that the electricity supply to the appliance is turned off.

Remove the cabinet front panel, place the fascia and control box in the Service Position and lower the expansion vessel into the Service Position, as described in Section 14.2 a, b and c.

Drain the heating and hot water circuit as described in Section 15.2.

Refer to Section 15.3 - 22 and remove the Top Manifold commencing from the instruction:

WARNING: The weight of the water to water heat exchanger is 2 kg. approx. A quantity of water will remain in the heat exchanger and pipework. Follow the procedure as described in Section 15.2.

Remove the manifold clear of the appliance

Remove and retain the brass stub connection and nut from the manifold.

Withdraw the by-pass adjuster retaining clip and unscrew the adjuster from the manifold retaining both items.

Undo and remove the phial pocket securing clip screw and clip. Retain both the clip and screw. Extract the phial pocket and retain.

Unscrew and retain all locating screws.

Before reassembling the appliance refit the by-pass adjuster and phial pocket in the reverse order using new "O" rings.

Screw all locating screws fully home then unscrew each of them two full turns. Check that none of the screws protrude into their relevant bores.

Reassemble the manifold in the reverse order using new "O" rings to replace any "O" rings which have been disturbed. Use new sealing washers where appropriate.

Ensure that all clips and screws are correctly refitted.

Open the valves, fill and re-pressurise the system as described in Section 12.2. Reassemble the appliance in the reverse order.

24. Water to Water Heat Exchanger Bottom Manifold.

See Figs. 16, 28, 29, 31, 32, 33, 34, 35, 37 and 38.

See Section 15.3 - 22 Water to Water Heat Exchanger.

Follow this procedure replacing the bottom manifold after the bottom manifold/water to water heat exchanger assembly has been removed from the appliance. Retain the original water to water heat exchanger and fit the new manifold using new "O" rings.

Reassemble the appliance as described in Section 15.3 - 22

25. Expansion Vessel. See Figs. 16 and 36.

Check that the electricity supply to the appliance is turned off.

Remove the cabinet front panel, place the fascia and control box in the Service Position and lower the expansion vessel into the Service Position, as described in Section 14.2 a, b and c.

Drain the heating circuit as described in Section 15.2 a.

Unscrew the union fitting on the right hand side of the expansion vessel and remove the sealing washer. Ease the expansion vessel assembly upwards to clear the support bracket and remove from the appliance. Take care when removing as a small quantity of water remains inside the vessel. Follow the procedure as described in Section 15.2.

Unscrew the fixing screw and remove the securing clip from the expansion vessel. Note the position of securing clip. Discard the expansion and sealing washer.

Fix the securing clip to the replacement expansion vessel. Replace the expansion vessel assembly into the support bracket and reconnect the union fitting using a new sealing washer.

Open the valves, fill and re-pressurise the system as described in Section 12.2.

Reassemble the appliance in the reverse order.

26. Expansion Vessel Flexible Hose. See Figs. 16 and 36.

Check that the electricity supply to the appliance is turned off.

Remove the cabinet front panel, place the fascia and control box in the Service Position and lower the expansion vessel into the Service Position, as described in Section 14.2 a, b and c.

Drain the heating circuit as described in Section 15.2 a.

Unscrew the union fitting on the right hand side of the expansion vessel. Remove and dispose of the sealing washer. Ease the expansion vessel assembly upwards to clear the support bracket and remove from the appliance. Take care when removing as a small quantity of water remains inside the vessel. Follow the procedure as described in Section 15.2.

Unscrew the union fitting on the right hand side of the heatbank. Remove and dispose of the sealing washer.

Reconnect the hose in the reverse order using new sealing washers. Ensure the orientation of the hose fittings does not cause twisting or crimping of the hose when the expansion vessel is repositioned in the boiler.

Open the valves, fill and re-pressurise the system as described in Section 12.2.

Reassemble the appliance in the reverse order.

Fig. 36. Expansion vessel and flexible hose.

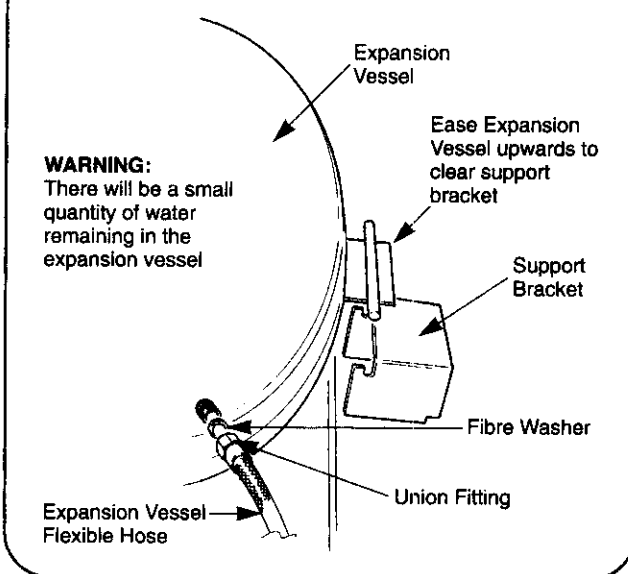

27. Pressure Relief Valve. See Fig. 37.

Check that the electricity supply to the appliance is turned off.

Remove the cabinet front panel, place the fascia and control box in the Service Position as described in Section 14.2 a, b and c.

Drain the heating circuit as described in Section 15.2 a.

Withdraw the securing clip from the top manifold and ease the pressure relief valve assembly forwards until clear of the appliance. Unscrew the manual air vent and disconnect the overflow pipe. Discard the valve and "O" ring.

Re-connect the overflow pipe and manual air vent to the replacement valve. Fit a new "O" ring seal to the valve.

Re-connect the assembly to the appliance and replace the securing clip.

Open the valves, fill and re-pressurise the system as described in Section 12.2. Reassemble the appliance in the reverse order.

28. Manual Air Vent. See Fig. 37.

Check that the electricity supply to the appliance is turned off.
Remove the cabinet front panel, place the fascia and control box in the Service Position as described in Section 14.2 a, b and c.
Drain the heating circuit as described in Section 15.2 a.
Remove the Pressure Relief Valve as described in Section 15.3-27.
Unscrew the manual Air Vent and discard along with its washer.
Replace with a new Manual Air Vent and washer.
Re-connect in the reverse order using new "O" rings where appropriate.
Reassemble the appliance in the reverse order.

29. Pressure Gauge. See Fig. 16.

Check that the electricity supply to the appliance is turned off.
Remove the cabinet front panel, place the fascia and control box in the Service Position and lower the expansion vessel into the Service Position, as described in Section 14.2 a, b and c.
Drain the heating circuit as described in Section 15.2 a.
Unscrew the pressure gauge out of the heat bank. Fit the replacement pressure gauge using a suitable thread sealing compound. Open the valves, fill and re-pressurise the system as described in Section 12.2.
Reassemble the appliance in the reverse order.

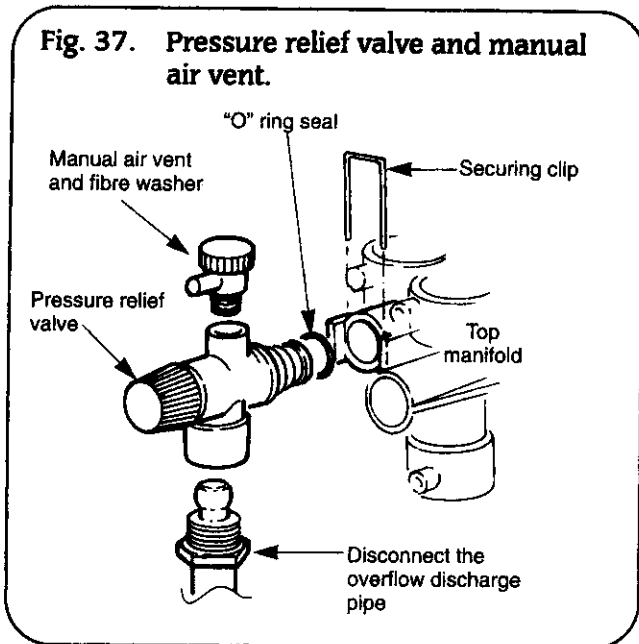

30. Flow Switch. See Fig. 38.

Check that the electricity supply to the appliance is turned off.
Remove the cabinet front panel, place the fascia and control box in the Service Position and lower the expansion vessel into the Service Position, as described in Section 14.2 a, b and c.
Drain the hot water circuit as described in Section 15.2 b.
Remove the fascia as described in Section 15.1. Unplug the Molex plug marked X1 "Flow Switch", from the control board. Release the strain relief bush by compressing the loose section of the bush and carefully withdraw the leads from the control box. Unscrew the two flat faced union fitting connecting the flow switch body to the mains cold water inlet. Remove the flow switch, leads and sealing washers clear of the appliance and discard.
Fit a replacement flow switch in the reverse order. Ensure the arrow on the end of the black plastic body points downwards and new sealing washers are fitted.
Reconnect the Molex plug.
Open the valve and fill the hot water circuit.
Reassemble the appliance in the reverse order.

31. Water Filter. See Fig. 38.

Check that the electricity supply to the appliance is turned off.
Remove the cabinet front panel, place the fascia and control box in the Service Position, as described in Section 14.2 a, b and c.
Drain the hot water circuit as described in Section 15.2 b.
Undo the flat faced union above the flow switch. Ease the flow switch and pipework sideways sufficiently to clear the union.
Remove the sealing washer and discard.
Undo the union below the mains water supply valve and remove the filter housing clear of the appliance. The water filter is located in the top of the housing. Remove the filter clean or replace.
Reassemble in the reverse order and replace the sealing washer. No sealing compound is required. Open the mains water valve and fill the hot water circuit.
Reassemble the appliance in the reverse order.

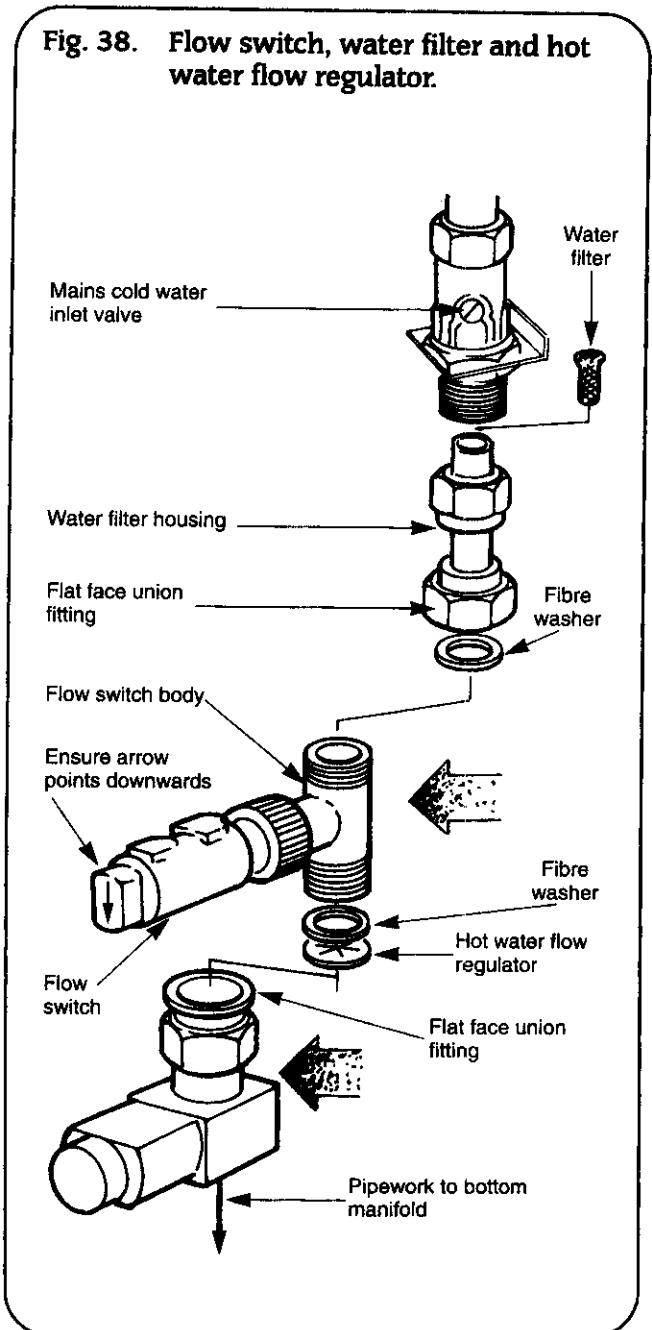
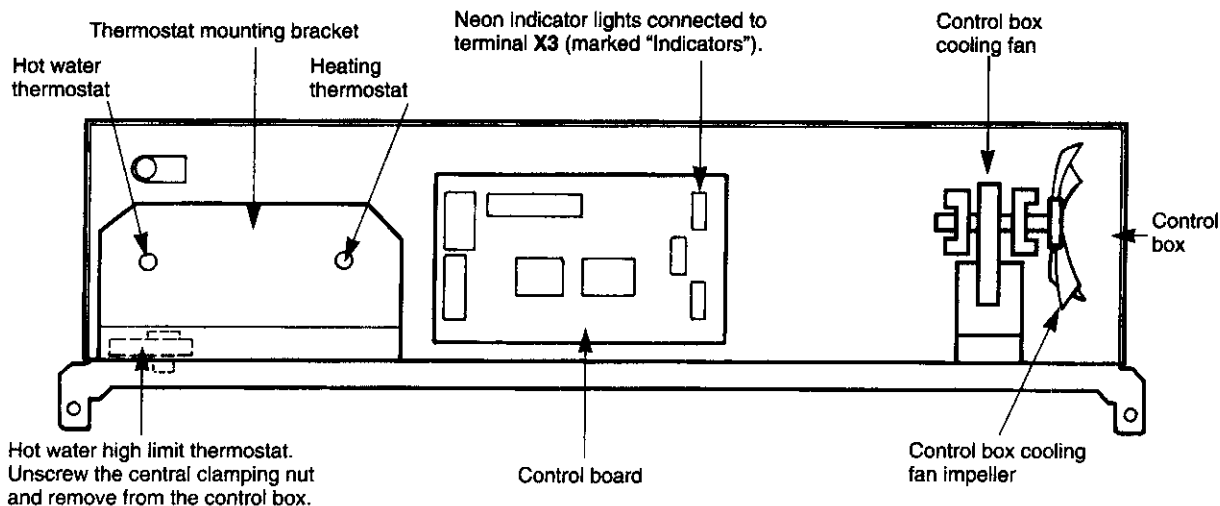

Fig. 39. Control Box.



32. Hot Water Flow Regulator. See Fig. 38.

Check that the electricity supply to the appliance is turned off.
 Remove the cabinet front panel, place the facia and control box in the Service Position, as described in Section 14.2 a, b and c.
 Drain the hot water circuit as described in Section 15.2 b.
 Undo the flat faced union below the flow switch. Ease the pipework sideways sufficiently to clear the flow switch. Remove the sealing washer and discard.
 The water flow regulator is located in the union fitting. It may be necessary to prise the regulator from its housing. Remove and discard.

Fit a new flow regulator, small diameter section first. Reassemble in the reverse order and replace the sealing washer. No sealing compound is required.

Open the mains water valve and fill the hot water circuit.

Reassemble the appliance in the reverse order.

33. Inner Casing Cover Seal. See Fig. 16.

Check that the electricity supply to the appliance is turned off.
 Remove the cabinet front panel, place the facia and control box in the Service Position.

Lower the expansion vessel into the Service Position and remove the inner casing cover, as described in Section 14.2 a, b and c.

Remove the inner casing cover as described in Section 14.2 d.

Remove the inner casing cover seal and discard. Fit a replacement seal using silicon adhesive. Check that the seal passes completely around the edge of the inner casing cover leaving no gaps.

Reassemble the appliance in the reverse order.

34. Operating Switch. See Figs. 8 and 12.

Check that the electricity supply to the appliance is turned off.
 Remove the cabinet front panel, place the facia and control box in the Service Position as described in Section 14.2 a and b.

Remove the facia as described in Section 15.1.

Remove the terminals from the rear of the switch making note of their positions. Squeeze together the two plastic retaining lugs to remove from the facia. Discard the switch.

Snap in the replacement switch and reconnect the terminals Refer to the wiring diagram. Reassemble the appliance in the reverse order.

35. Control Board. See Figs. 8 and 39.

Check that the electricity supply to the appliance is turned off.
 Remove the cabinet front panel, place the facia and control box in the Service Position as described in Section 14.2 a and b.

Remove the facia as described in Section 15.1.

Carefully pull off all the Molex plugs, note the positions. Disconnect the room thermostat and frost thermostat if fitted, note the positions.

Disconnect the mains supply at the terminal strip located bottom left hand corner of the control board, marked X11 "Mains Supply". Unplug the Operating Switch or programmer if fitted, from terminal marked X12 "Programmer/Switch".

Release the plastic catch at each mounting post pulling the printed circuit board forward approximately 3mm to prevent the plastic catch from returning. Pull the board off the remainder of the mounting post until it is free. Discard the board.

Locate the new board over the four mounting posts and push back squarely until the plastic catch on the end of each post clicks into place.

Fig. 40. Control box and thermostat bracket.

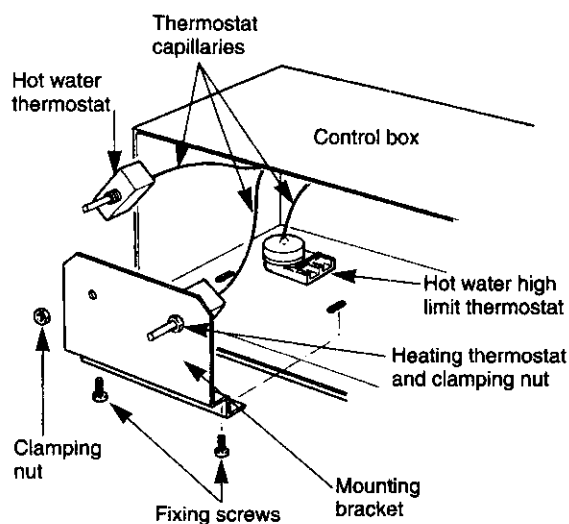

Reassemble in the reverse order and ensure that :

- (i) the mains supply, room and frost thermostat are connected correctly.
- (ii) the Operating Switch or programmer is plugged into the terminal strip.
- (iii) the Molex connectors are fitted to the correct terminals. Connectors are not interchangeable and will only fit the terminals from which they were removed.

Refer to the wiring diagram. Reassemble the fascia in the reverse order.

36. Facia Mounted Programmer. See Figs. 8 and 12.

Check that the electricity supply to the appliance is turned off.

Remove the cabinet front panel, place the facia and control box in the Service Position as described in Section 14.2 a and b.

Remove the facia as described in Section 15.1.

Unplug the programmer from the control board from terminals marked X12 "Programmer/Switch". Undo the four nuts securing the programmer to the facia and remove. Fit a new programmer in the reverse order and connect the plug at the driver board.

Reassemble the facia in the reverse order.

37. Remote Mounted Programmer. See Fig. 11.

Check that the electricity has been turned off and isolate the programmer.

Disconnect the leads from the programmer noting there alignment. Fit the replacement programmer and reconnect the leads checking that they are correctly positioned.

38. Neon Indicator Lights. See Figs. 8, 12, 41 and 42.

Check that the electricity supply to the appliance is turned off.

Remove the cabinet front panel, place the facia and control box in the Service Position as described in Section 14.2 a and b.

Remove the facia as described in Section 15.1.

Unplug the neon connection at terminal X3 (marked "Indicators") on the control board. Use an electrical screwdriver to carefully push down through the locking clip slot to depress the locking clips and withdraw the appropriate leads of the failed neon.

Remove the neon from the facia panel.

Push the replacement neon into the facia panel. Insert the new neon leads into the plug with the locking clip in the correct position.

Reconnect the plug to the control board referring to the wiring diagram.

Reassemble the facia in the reverse order.

39. Control Box Cooling Fan. See Figs. 8, 12 and 39.

Check that the electricity supply to the appliance is turned off.

Remove the cabinet front panel, place the facia and control box in the Service Position as described in Section 14.2 a and b.

Remove the facia as described in Section 15.1.

Carefully disengage the electrical connections from the fan motor.

Note the orientation of the fan and remove the two screws on the underside of the control box securing the mounting bracket. Withdraw the fan from the control box and discard.

Fit the new fan in the reverse order ensuring the fan orientation is correct.

Reassemble the facia in the reverse order.

40. Control Box Cooling Fan Impeller. See Figs. 8, 12 and 39.

Check that the electricity supply to the appliance is turned off.

Remove the cabinet front panel, place the facia and control box in the Service Position as described in Section 14.2 a and b.

Remove the facia as described in Section 15.1.

Carefully disengage the electrical connections from the fan motor.

Note the orientation of the fan and remove the two screws on the underside of the control box securing the mounting bracket. Withdraw the fan from the control box.

The impeller is push fitted on to the motor boss and may be eased from the boss with the aid of a screwdriver.

Fit the new impeller by laying it on a hard flat surface and pushing the motor BOSS carefully into it until it is fully engaged. Before refitting the fan check that the impeller turns freely.

Refit the fan in the reverse order ensuring the fan orientation is correct.

Reassemble the facia in the reverse order.

Fig. 41. Neon indicator light plugs.

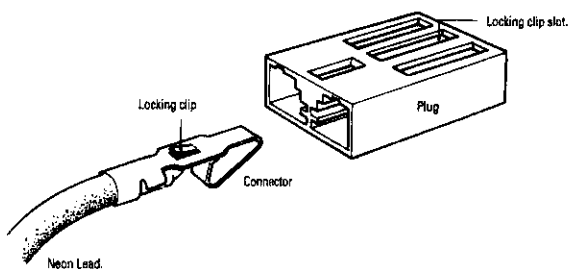
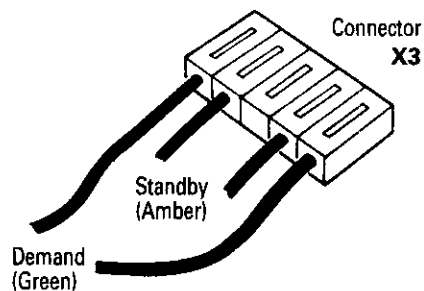
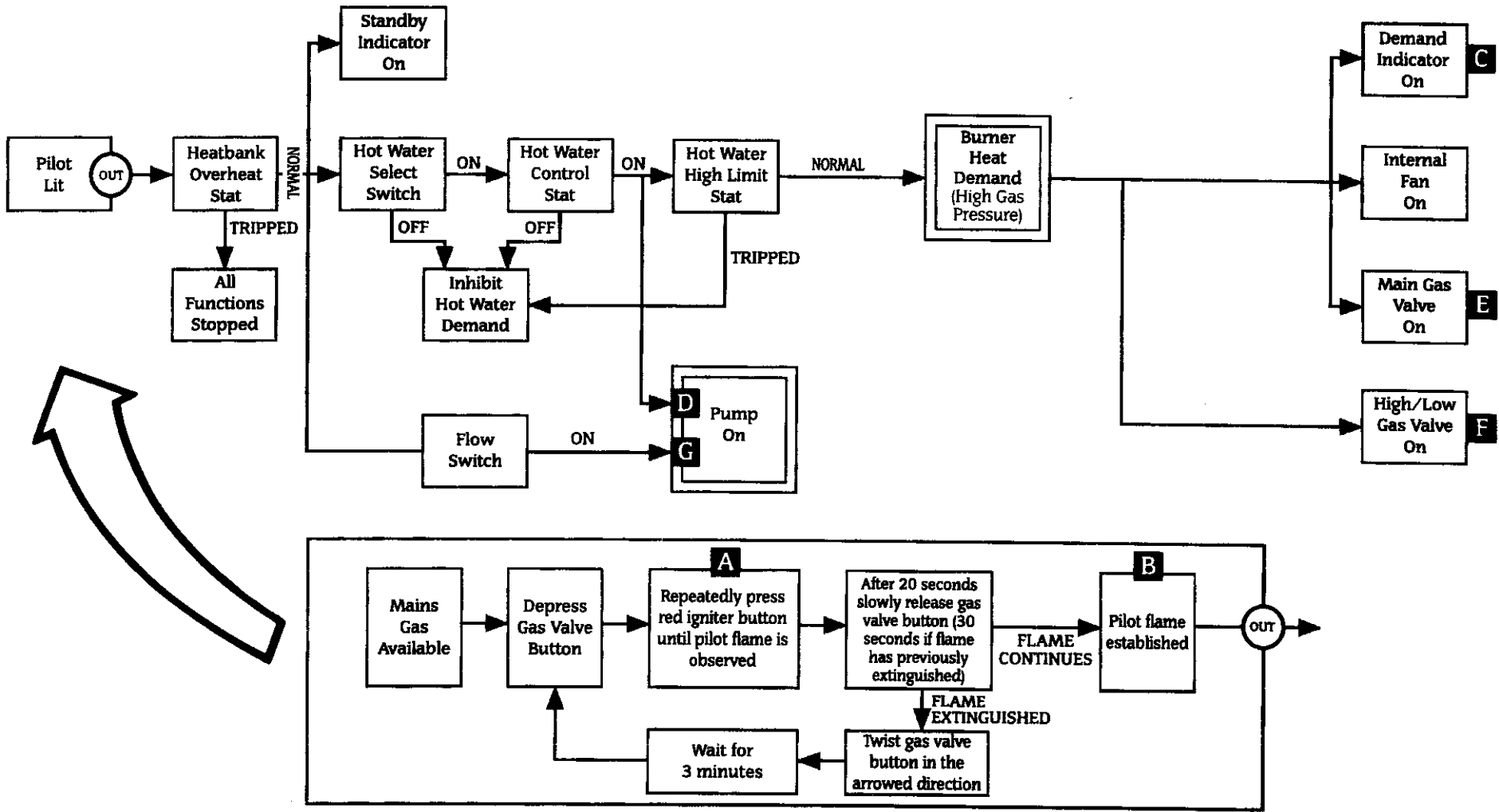

Fig. 42. Neon indicator light connections.



**Domestic Hot Water Operational Flow Diagram
(CH Selected Off)**



Note: The alpha references in these charts are to be used for cross-referencing when fault finding. See Section 17.

16. Operational Flow Diagrams

**Central Heating Operational Flow Diagram
(HW Selected Off)**

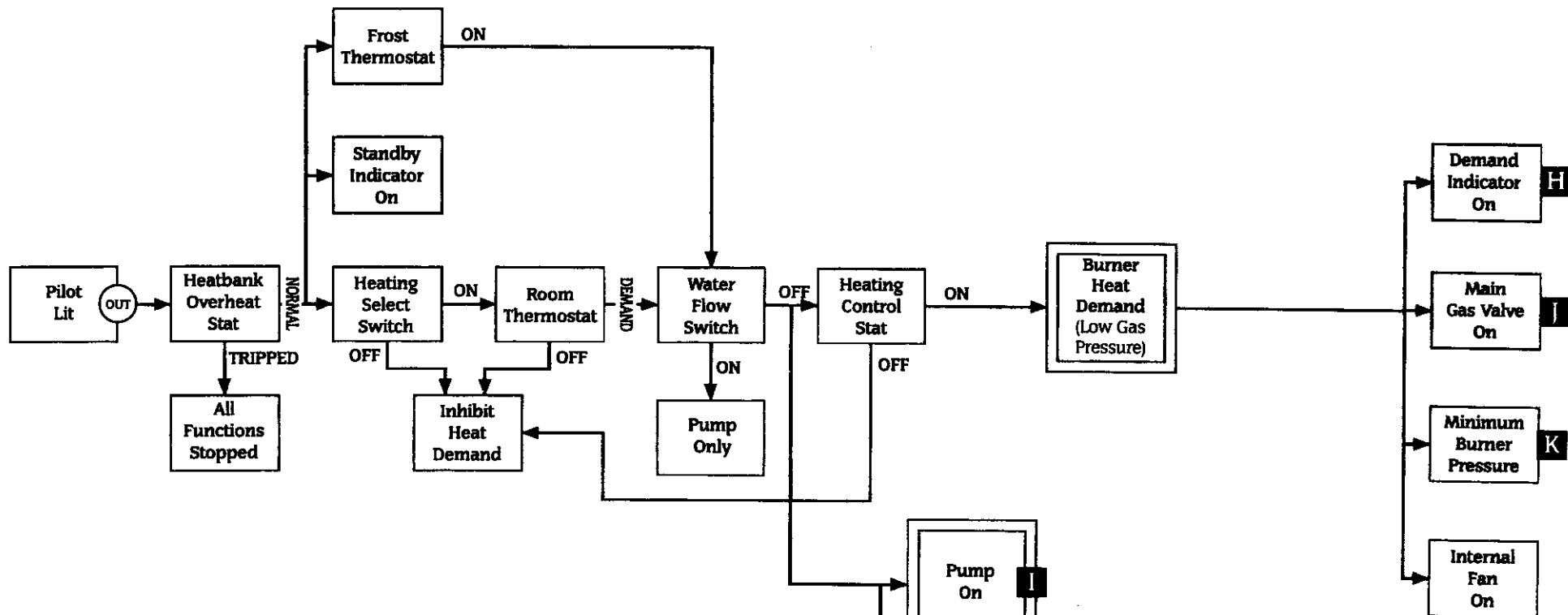

**Pump Overrun Function
(No normal demands)**

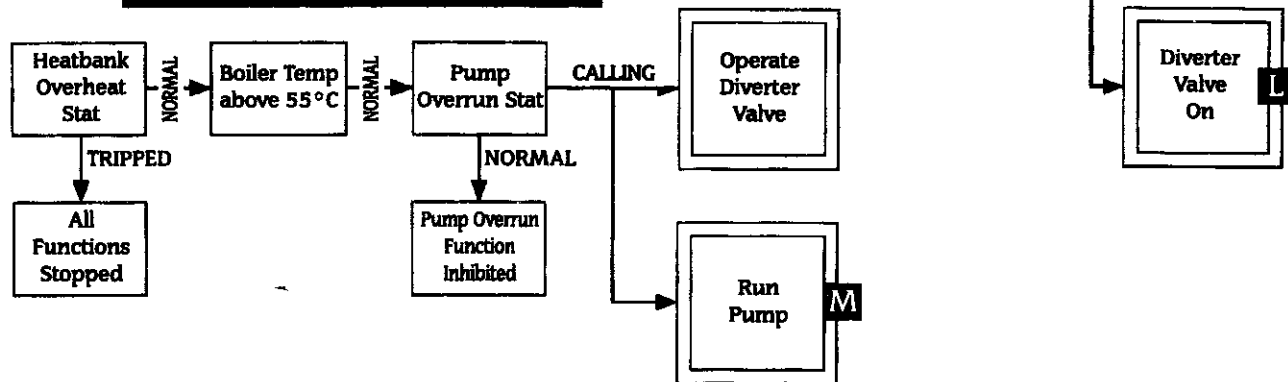

17. Fault Finding

This Fault Finding Chart is to be used in conjunction with the Operational Flow Diagrams in Section 16. To find the fault, locate the point on the flow diagram at which the appliance has failed, e.g. letter B. Then read the corresponding section in the fault finding chart, e.g. **Failure at point B**. **Note:** Each section assumes that the appliance operates correctly up to that point.

Note: 1. All voltage measurements are with respect to neutral unless otherwise stated. 2. Before changing any component indicated in the chart, it is essential that the associated wiring is checked for continuity, condition and correct routing. 3. Preliminary electrical system checks are the first electrical checks to be carried out during a fault finding procedure. On completion of the Service/Fault Finding task which has required the breaking and remaking of electrical connections, check – (a) EARTH CONTINUITY, (b) SHORT CIRCUIT CHECK, (c) POLARITY and (d) RESISTANCE TO EARTH.

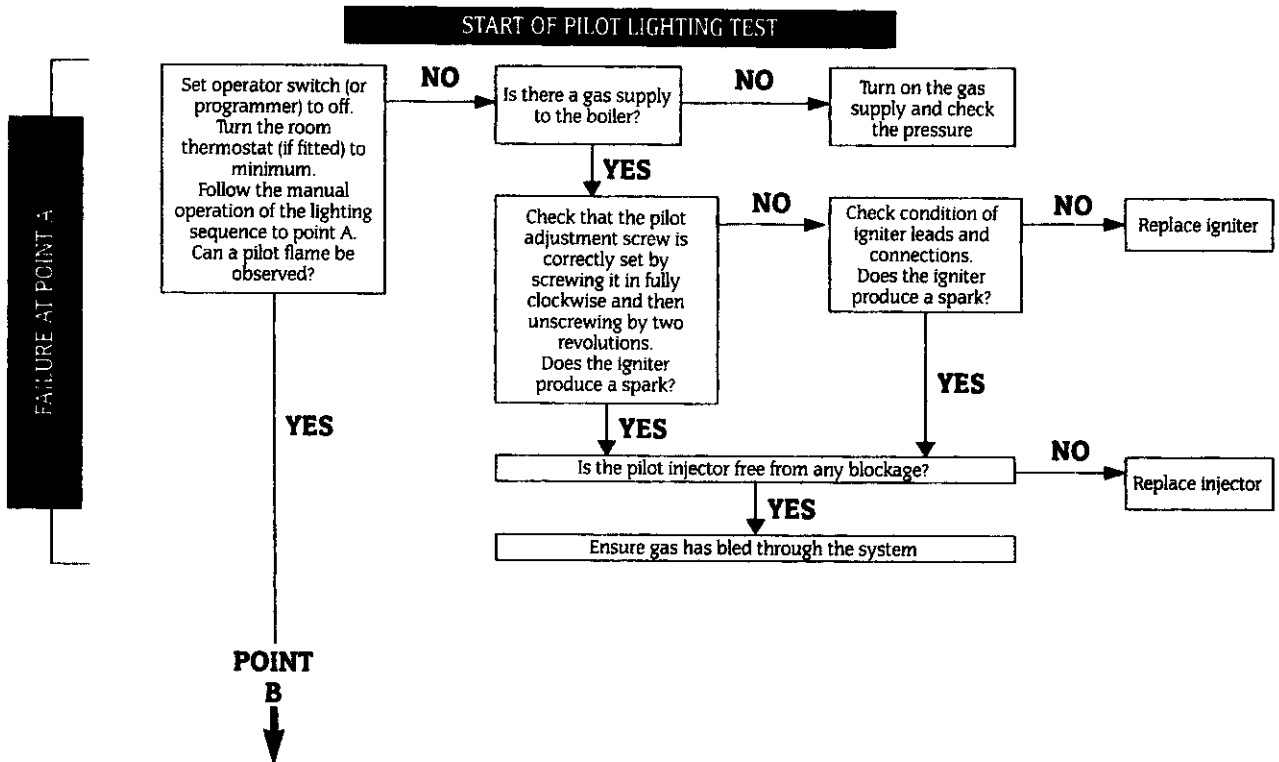
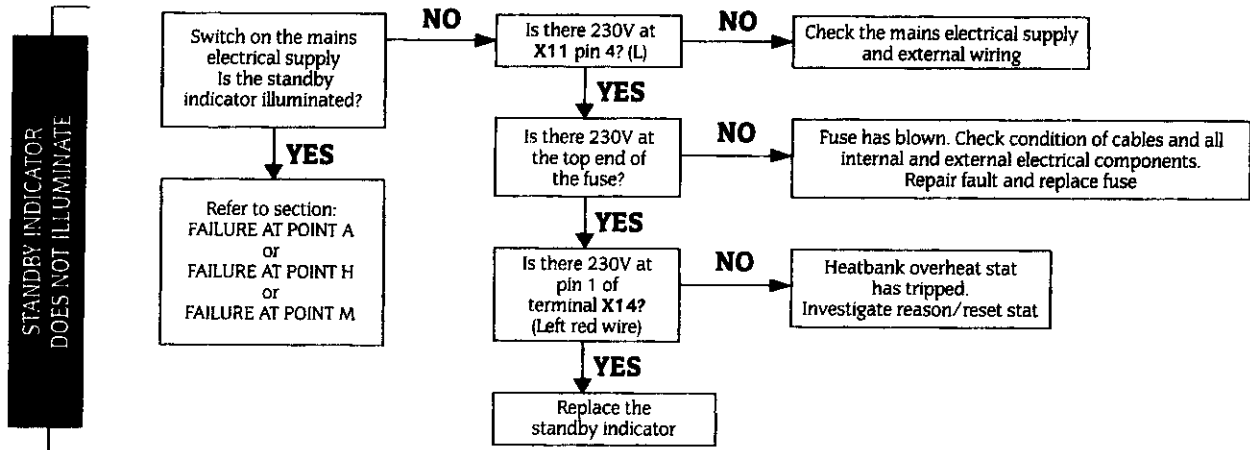

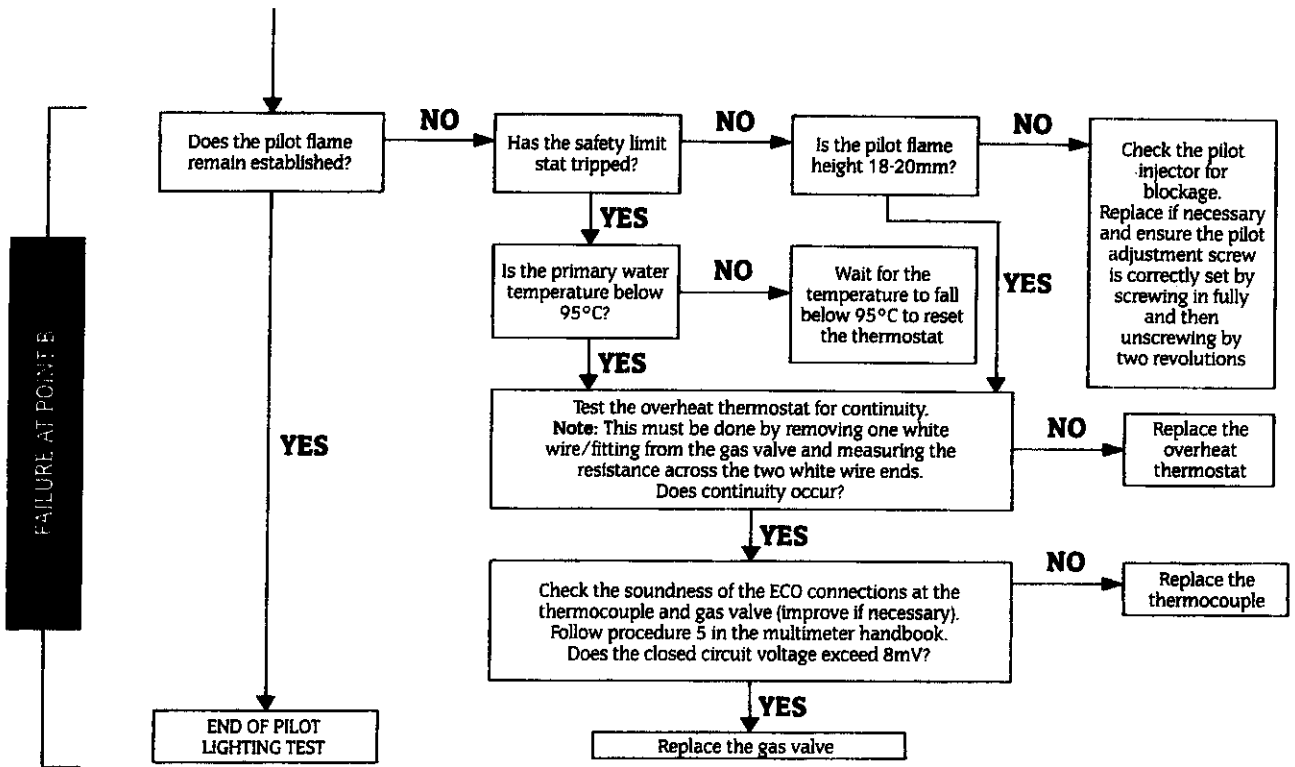

START OF DOMESTIC HOT WATER TEST

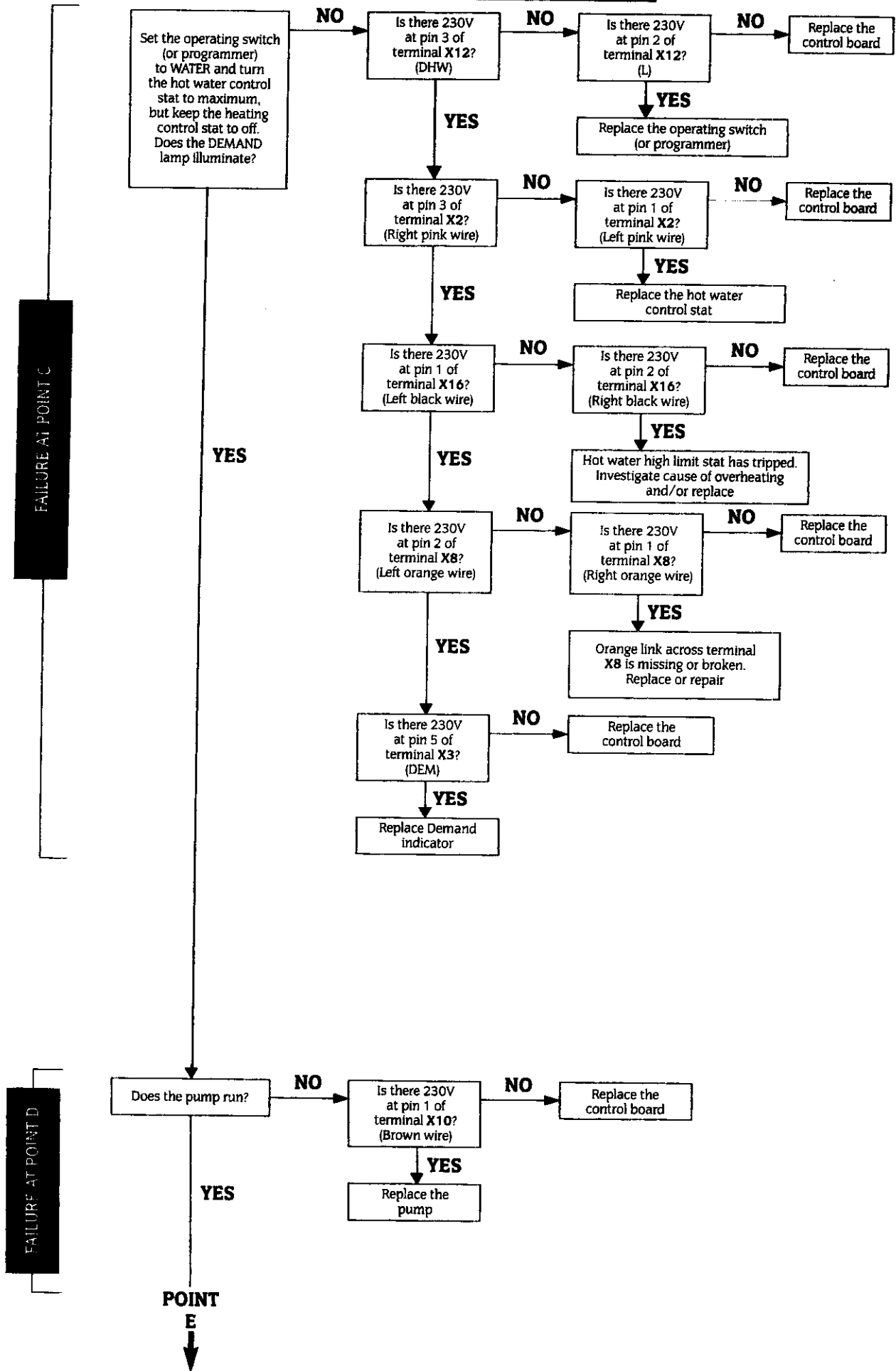

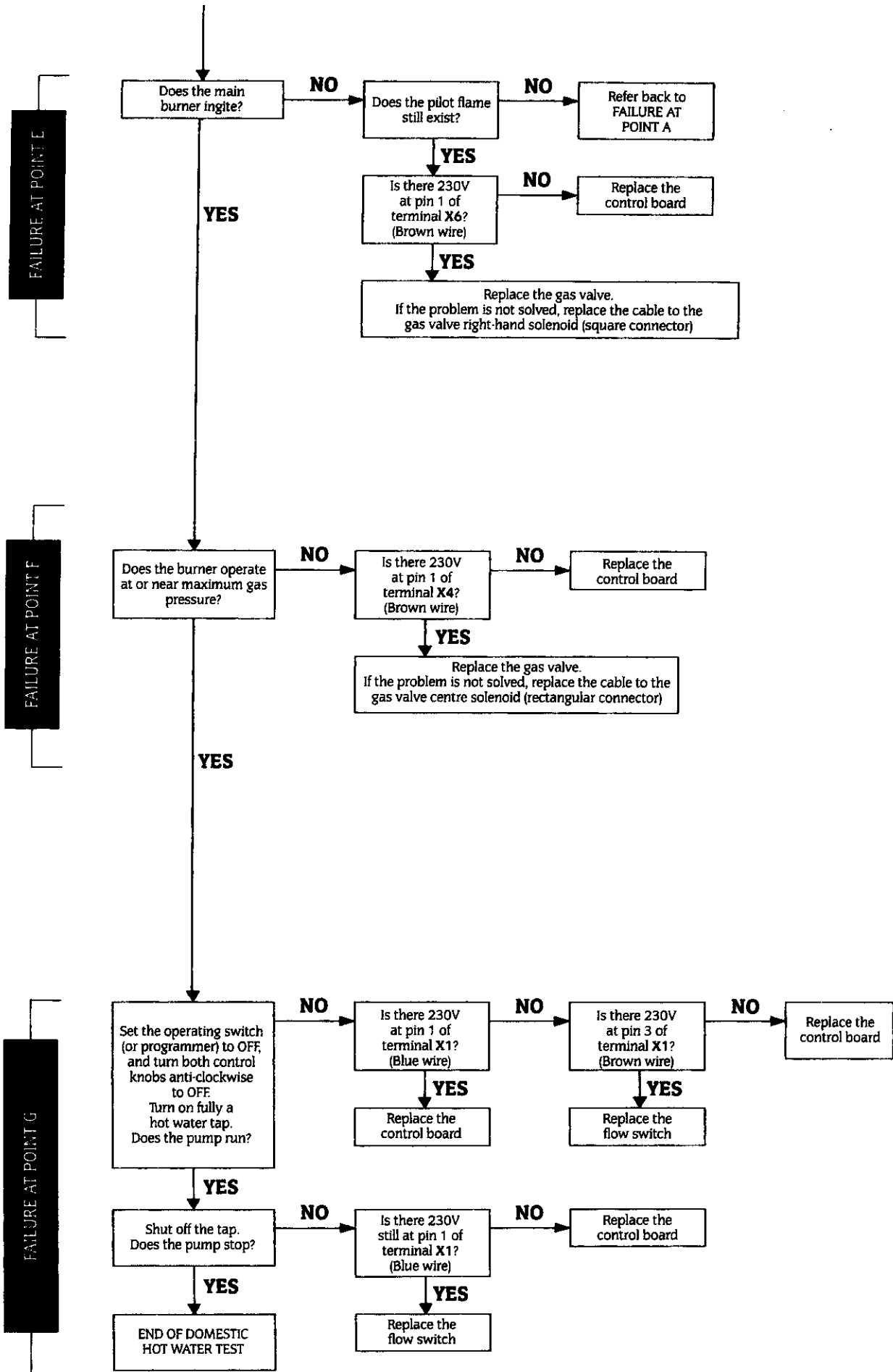

START OF CENTRAL HEATING TEST

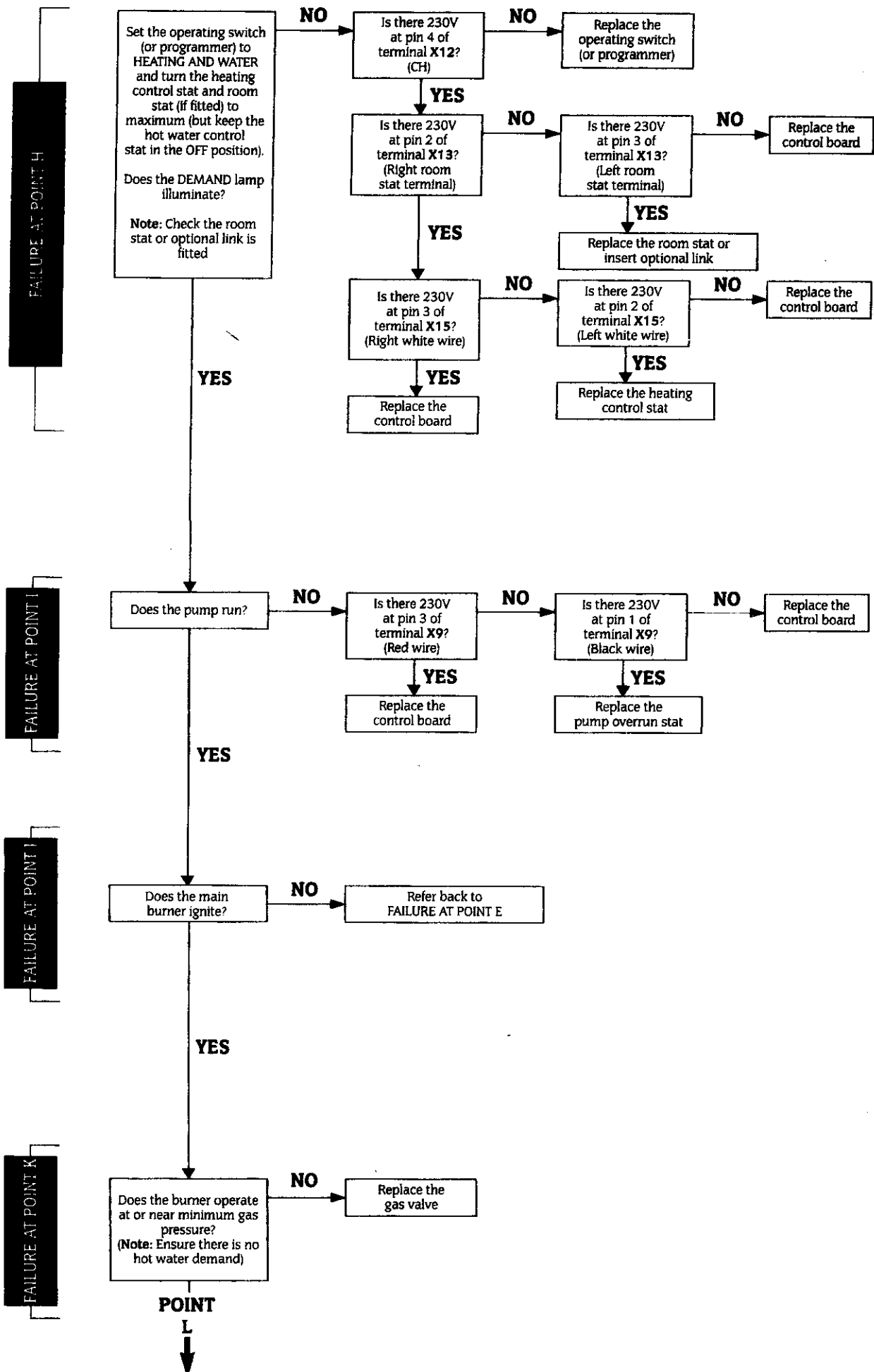

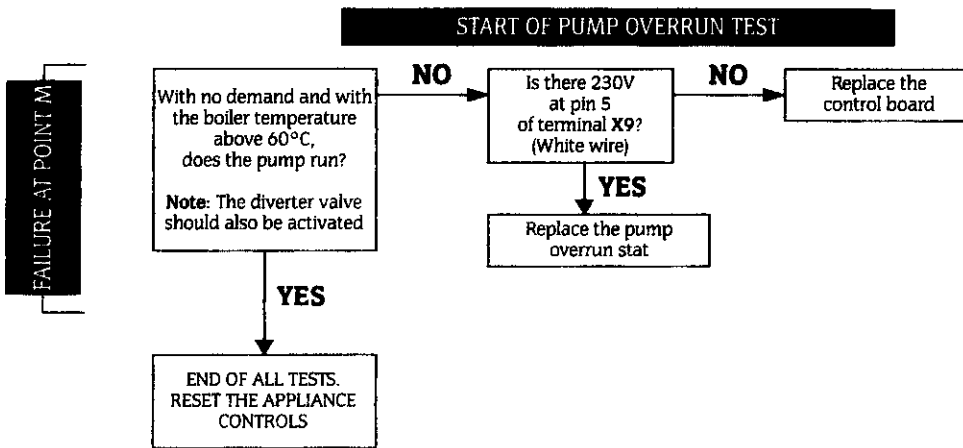
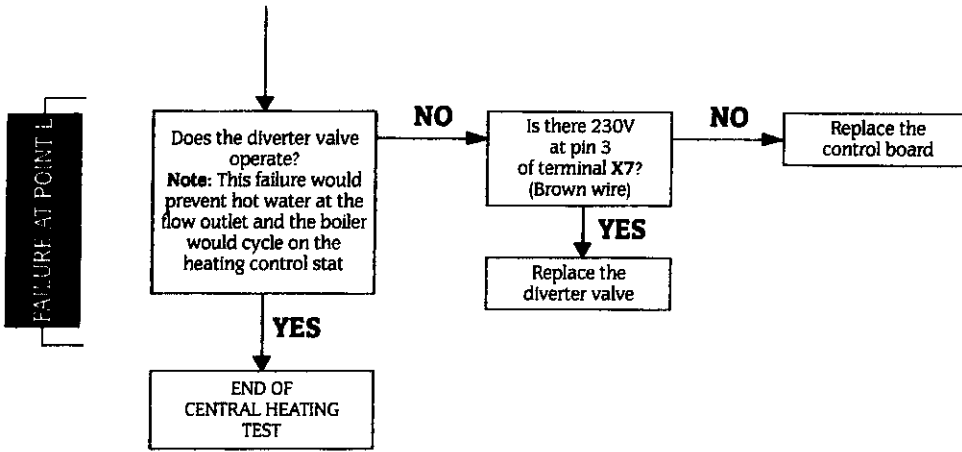

18. Short Parts List

Key No.	GC No.	Description	Manufacturer's Reference	Qty	WHS Part No.
1	378 381	BF Burner	Aeromatic	1	ZAGAS003
2	379 040	Injector (4.4mm diameter)		1	ZAGAS163
3	299 324	Gas Valve	Honeywell V4600Q2125	1	ZAGAS231
4	379 673	Pilot Burner	Honeywell Q385A2010 F-Tip	1	ZBGAS092
5	382 850	Pilot Injector	Honeywell 45.004.108.001	1	ZBGAS016
6	390 210	Thermocouple	Honeywell Q309A2747 700mm	1	ZBGAS035
7	386 575	Electrode	Honeywell 45.900.413.004	1	ZBGAS093
8	299 183	Electrode Lead Assembly (220mm)		1	ZBGAS047
9	393 652	Peizo Generator		1	ZBGAS010
10	299 328	Gas to Water Heat Exchanger (with washers)		1	ZAGAS165
11	374 607	Combustion Chamber Insulation (complete)		1	SPK0034
12	379 419	Auto Air Vent	Intermes 02.50.010	1	ZMMIS055
13	386 244	Pressure Gauge (with washer)	Cewal	1	ZBUNC205
14	378 810	Pressure Relief Valve	Caleffi 3141 3bar	1	ZCVLV006
15	386 224	Pump with "O" Rings	Grundfos 15-60 Special	1	ZAMAJ168
16	299 341	Expansion Vessel (12 litres with washers)		1	ZMMIS207
17	299 323	DHW Heat Exchanger (with "O" Rings)	SWEP	1	ZAMAJ079
18	299 329	Water Diverter Valve (with "O" (5 + 2)	Bosch	1	ZAMAJ081
19	378 813	PCB Boiler Control (relay board)	Pactrol	1	ZAGAS237
20	299 330	Heatbank O/H Thermostat (BBA)	Ranco LM7 P5079	1	ZAGAS044
21	299 152	Safety Temperature Limiter	Elmwood 2455	1	SSAHAR013
22	299 332	CH Thermostat	Ranco K36 P1332	1	ZAGAS041
23	299 332	HW Thermostat	Ranco K36 P1333	1	ZAGAS042
24	299 333	HW Limit Thermostat	Elmwood	1	SSAHAR253
25	299 277	Pump Overrun Thermostat	Thermodisc 60T	1	ZAMAJ165
26	386 778	Operating Switch	Arrow 2004E	1	ZDELE237
27	371 539	Programmer Kit (Optional)	WHS Single Channel	1	ZAMAJ164
28	371 524	Neon (Green)	IMO Ref. NI9L 240R/S Green	1	SSAHAR081
29	371 525	Neon (Amber)	IMO Ref. NI9L 240 R/S Amber	1	SSAHAR082
30	324 822	Gauze Filter	3/5211 Worcester	1	ZBUNC230
31	378 809	Manual Air Vent	1/4 BSP	1	ZMMIS097
32	299 336	Flow Switch Assembly (with washers)	SIKA	1	SSA010781
33	378 811	Flow Regulator	Type A 18 l/min. ± 15%, Purple	1	ZBUNC204
34	299 337	Expansion Vessel Flexible Hose (with washers)		1	ZMMIS183
35	299 093	Inner Casing Seal		1	ZEGAS090
36	299 342	Top Manifold Block (with "O" Rings)		1	ZBUNC227
37	299 343	Bottom Manifold Block (with "O" Rings)		1	ZBUNC228
38	299 345	Control Box Cooling Fan – Impeller		1	ZBUNC212
39	378 825	Control Box Cooling Fan		1	ZDELE148
40	299 346	Gasket Pack		1	SPK0134

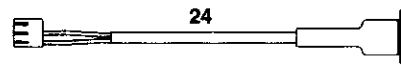
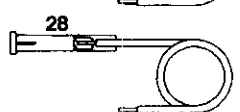
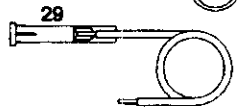
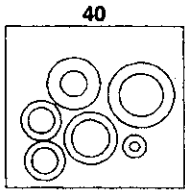
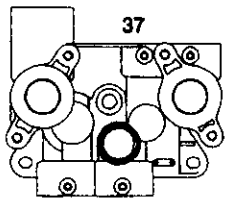
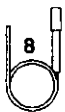
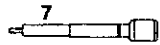
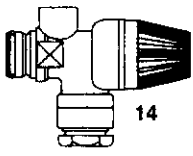
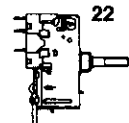
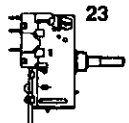
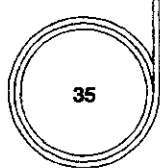
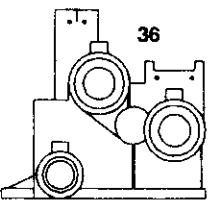
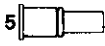
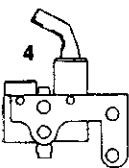
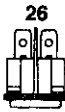
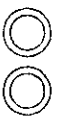
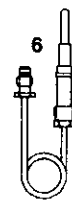
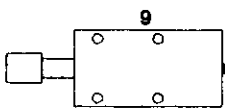
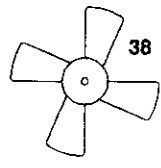
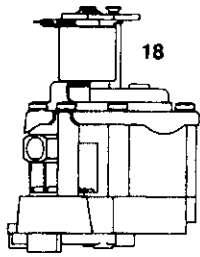
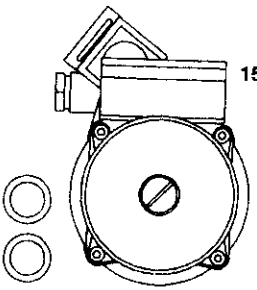
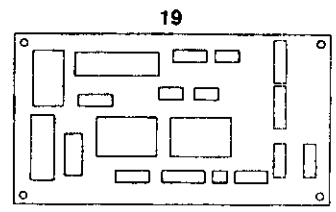
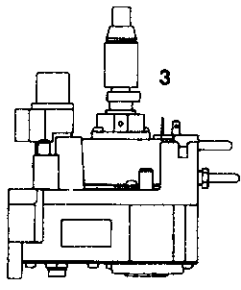
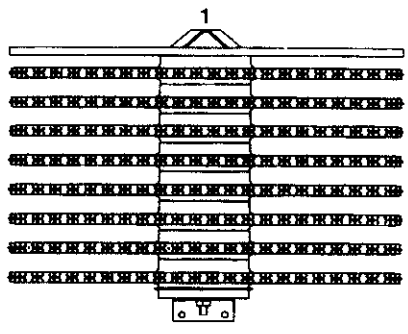
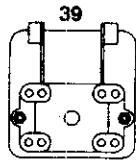
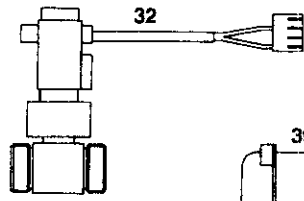
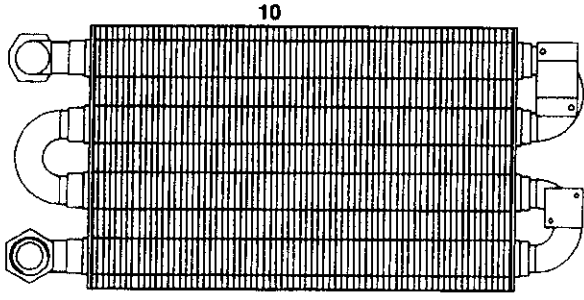
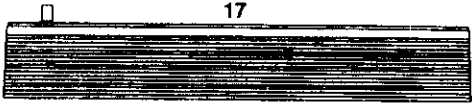
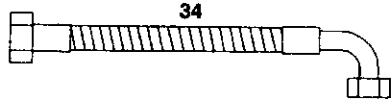
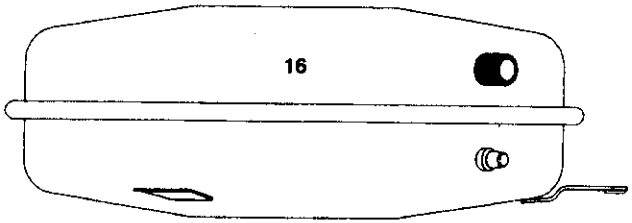
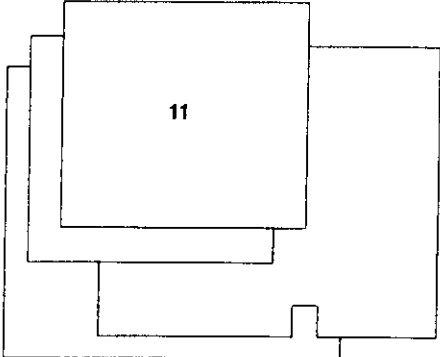



*Worcester Heat Systems Limited, Cotswold Way, Warndon, Worcester WR4 9SW.
Telephone: (01905) 754624. Fax: (01905) 754619.*

This booklet is accurate at the date of printing but will be superseded and should be disregarded if specifications and/or appearances are changed in the interests of continued improvement.

All goods sold are subject to our official Conditions of Sale, a copy of which may be obtained on application.

PUBLICATION ZKLIT109, ISSUE 1 -- JULY 1995

8 716 145 307