

GREENSTAR CAMRAY UTILITY & UTILITY SYSTEM 12/18, 18/25, 25/32

FLOOR STANDING OIL FIRED CONDENSING BOILER
CONVENTIONAL FLUE & ROOM SEALED FLUE

FOR FULLY PUMPED OPEN VENT OR SEALED CENTRAL HEATING SYSTEMS AND DOMESTIC
HOT WATER CYLINDERS

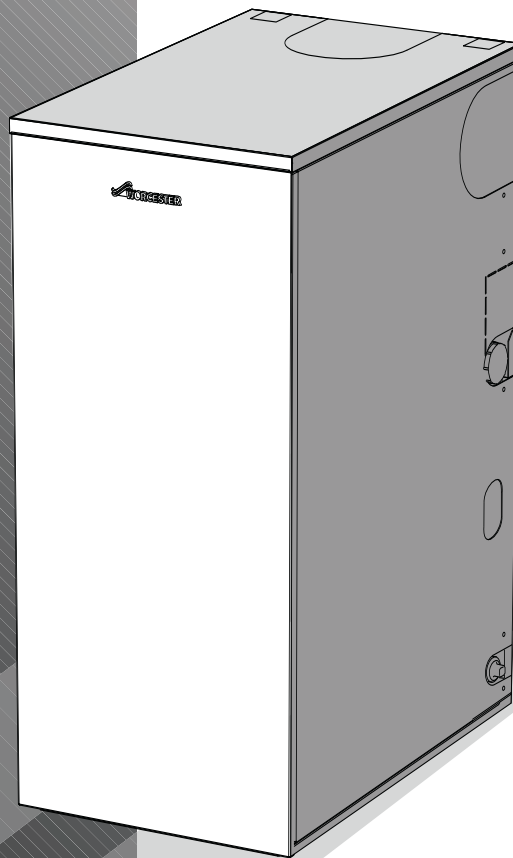

THE APPLIANCE IS FOR USE WITH 28 SECOND KEROSENE
ONLY

GB

INSTRUCTION MANUAL
INSTALLATION COMMISSIONING
& SERVICING

INSTALLATION & SERVICING INSTRUCTIONS

SYMBOLS USED IN THIS MANUAL:



Domestic hot water



Central heating



Electricity supply

PLEASE READ THESE INSTRUCTIONS CAREFULLY BEFORE STARTING INSTALLATION.

THESE INSTRUCTIONS ARE APPLICABLE TO THE WORCESTER APPLIANCE MODEL(S) STATED ON THE FRONT COVER OF THIS MANUAL ONLY AND MUST NOT BE USED WITH ANY OTHER MAKE OR MODEL OF APPLIANCE.

THE INSTRUCTIONS APPLY IN THE UK ONLY AND MUST BE FOLLOWED EXCEPT FOR ANY STATUTORY OBLIGATION.

THIS APPLIANCE MUST BE INSTALLED BY A COMPETENT PERSON. FAILURE TO INSTALL CORRECTLY COULD LEAD TO PROSECUTION.

COMPLYING WITH THE BUILDING REGULATIONS:

This heating appliance forms part of the controlled services for the building. It is law that all controlled services for buildings must comply with building regulations. You must be able to satisfy your Local Authority Building Control Body (LABC) that the work carried out concerning the installation and commissioning of this heating appliance has been carried out to a satisfactory standard.

OFTEC operate a competent persons scheme and registered installers are able to certify that their work complies with building regulations. Under the scheme;

- OFTEC must be informed about every installation.
- OFTEC will issue a building regulations compliance certificate to the householder and will notify the LABC.

OFTEC provide controlled document forms CD10 and CD11 for use during installation and commissioning respectively.

Other organisations operate self-certification schemes e.g. NAPIT and BESCA Ltd. and it may be possible for installers who are members of these organisations to self certify their work.

Alternatively you must submit a building control notice to the LABC before installing any boiler. The LABC will then arrange regular inspection visits during the work to ensure that the installation complies with the regulations.

IF YOU ARE IN **ANY DOUBT** CONTACT THE WORCESTER TECHNICAL HELPLINE.

DISTANCE LEARNING AND TRAINING COURSES ARE AVAILABLE FROM WORCESTER.

PLEASE LEAVE THESE INSTRUCTIONS WITH THE COMPLETED COMMISSIONING FORM AND THE USER MANUAL WITH THE OWNER OR WITH THE APPLIANCE AFTER INSTALLATION OR SERVICING. THE SERVICE INTERVAL RECORD CAN BE FOUND ON THE BACK PAGE OF THIS MANUAL.

ABBREVIATIONS USED IN THIS MANUAL:

Ø	Diameter
CH	Central Heating
DHW	Domestic Hot Water
TRV	Thermostatic Radiator Valve
IP	Ingress Protection
CF	Conventional flue
BF	Balanced flue
N/A	Not allowed
SEDBUK	Seasonal Efficiency of Domestic Boilers in the United Kingdom
OFTEC	Oil Firing Technical Association for the Petroleum Industry
IEE	Institute of Electrical Engineers
LABC	Local Authority Building Control Body

STORE THE APPLIANCE IN A DRY AREA PRIOR TO INSTALLATION.

Check List

Item	Qty
Greenstar Camray Utility & Utility System Installation/Servicing Instructions.....	1
Users Instructions	1
Warranty Return Envelope	1
Guarantee Registration Card.....	1
Condensate Trap Kit.....	1
Return Pipe Kit.....	1

IMPORTANT HANDLING INSTRUCTIONS:

It is advised that more than one person is involved in the transfer of the packaged appliance from the van to the point of installation. It is advised that no attempt should be made to move the packaged appliance without the use of a suitable truck.

At all times the correct method for handling heavy objects should be strictly observed.

GENERAL HANDLING GUIDELINES:

- Lift only a manageable weight, or ask for help.
- When lifting, bend the knees, and keep the back straight and feet apart.
- Do not lift and twist at the same time.
- Lift and carry items close to the body.
- Wear protective clothing and gloves to protect from any sharp edges.

CONTENTS

SAFETY & REGULATIONS

IMPORTANT INFORMATION AND SYMBOLS	1
SAFETY PRECAUTIONS AND INSTALLATION REGULATIONS	3

APPLIANCE INFORMATION

GENERAL INFORMATION	4
TECHNICAL DATA	5
LAYOUT & COMPONENTS UTILITY	6
LAYOUT & COMPONENTS UTILITY SYSTEM	7

PRE-INSTALLATION

CLEANING PRIMARY SYSTEMS	8
MAINS SUPPLY	9
OIL SUPPLY	10
WATER SYSTEMS & PIPEWORK	11-12
CONDENSATE PIPEWORK	13
PRESSURE RELIEF PIPEWORK	13
BOILER LOCATION & CLEARANCES	14-15
FLUE TERMINAL POSITIONS	16
CONVENTIONAL FLUE	17
ROOM SEALED FLUE OPTIONS	18

INSTALLATION

UNPACKING THE BOILER	19
PIPEWORK POSITIONS / FLUE OPENING	20
BOILER INSTALLATION	21
FLUE INSTALLATION	22
COMBUSTION CHAMBER	23
PIPEWORK CONNECTIONS	24
OIL BURNER AND PUMP	25
REFITTING COMPONENTS	26
ELECTRICS	27-31

COMMISSIONING

PRE-COMMISSIONING CHECKS - APPLIANCE	32
FILLING THE SYSTEM	33
STARTING THE APPLIANCE	34-37
WATER TREATMENT	38
FINISHING COMMISSIONING - APPLIANCE	39

SERVICING & SPARES

INSPECTION AND SERVICE	40-43
SHORT PARTS LIST 12/18	44
SHORT PARTS LIST 18/25	45
SHORT PARTS LIST 25/32	46

FAULT FINDING & DIAGNOSIS

FAULT FINDING	47-48
FAULT FINDING LOGIC FOR 535 SE/LD RDB CONTROL BOX	49
COMBUSTION RECORD	50
SERVICE INTERVAL RECORD	51
BAFFLE ARRANGEMENT DIAGRAM	BACK PAGE

SAFETY &
REGULATIONS

APPLIANCE
INFORMATION

PRE -
INSTALLATION

INSTALLATION

COMMISSIONING

SERVICING
& SPARES

FAULT FINDING
& DIAGRAMS

NOTES

SAFETY PRECAUTIONS

OIL SMELLS, LEAKS OR FUMES FROM THE APPLIANCE:

- ▶ Extinguish any naked flames.
- ▶ Open windows and doors.
- ▶ Isolate the electrical supply.
- ▶ Isolate the fuel supply to the boiler.
- ▶ Rectify fault.

HEALTH & SAFETY:

The appliance contains no asbestos and no substances have been used in the construction process that contravene the COSHH Regulations (Control of Substances Hazardous to Health Regulations 1988). Where applicable, the CE mark indicates compliance with relative EU Directives.

COMBUSTIBLE AND CORROSIVE MATERIALS:

Do not store or use any combustible materials (paper, thinners, paints etc.) inside or within the vicinity of the appliance.

The combustion air must be kept clear of chemically aggressive substances which can corrode the appliance and invalidate any warranty.

FITTING & MODIFICATIONS:

Fitting the appliance and any controls to the appliance may only be carried out by a competent engineer in accordance with these instructions and the relevant Installation Regulations.

Flue systems must not be modified in any way other than as described in the fitting instructions. Any misuse or unauthorised modifications to the appliance, flue or associated components and systems could invalidate the warranty. The manufacturer accepts no liability arising from any such actions, excluding statutory rights.

SERVICING:

Advise the user to have the system regularly serviced by a competent, qualified engineer (such as OFTEC registered personnel) using approved spares, to help maintain the economy, safety and reliability of the appliance.

INSTALLATION REGULATIONS

Failure to install appliances correctly could lead to prosecution.

The appliance should be installed by a competent person. The person installing the appliance should be aware of the Health and Safety at Work Act and take appropriate action to ensure that the regulations are adhered to. In order to give optimum efficiency and trouble free operation the appliance must be commissioned by a qualified OFTEC engineer.

The compliance with a British Standard does not, in itself, confer immunity from legal obligations. In particular the installation of this appliance must be in accordance with the relevant requirements of the following British Standards and regulations in respect of the safe installation of equipment:

BS 5410: part 1: Code of practice for Oil Fired Boilers.

BS 799: part 5: Specification for Oil Storage Tanks.

BS 7593: Code of Practice for treatment of water in domestic hot water central heating systems.

BS 5449: part 1: Specification for forced circulation hot water central heating for domestic premises.

BS 5955: part 8: Specification for the installation of thermoplastic pipes and associated fittings for use in domestic hot and cold water services and heating systems.

BS 7291: Thermoplastic pipes and associated fittings for hot and cold water for domestic purposes and heating installations in buildings.

BS 7074: part 1: Application, selection and installation of expansion vessels and ancillary equipment for sealed water systems.

BS 7671: IEE Wiring Regulations, current edition.

BS 1362: Specification for general purpose fuse links for domestic and similar purposes.

The Building Regulations Part J and L1 England and Wales; Part F and Part J Section III Scotland; Part L and Part F Northern Ireland.

Local water company bye-laws.

The Control of Pollution (Oil) Regulations.

OFTEC Standards.

Where no specific instruction is given, reference should be made to the relevant codes of practice.

GENERAL INFORMATION

STANDARD PACKAGE:

- A - Floor standing oil fired condensing boiler.
- B - Literature pack.
- C - Condensate trap kit.
- D - Return pipe.

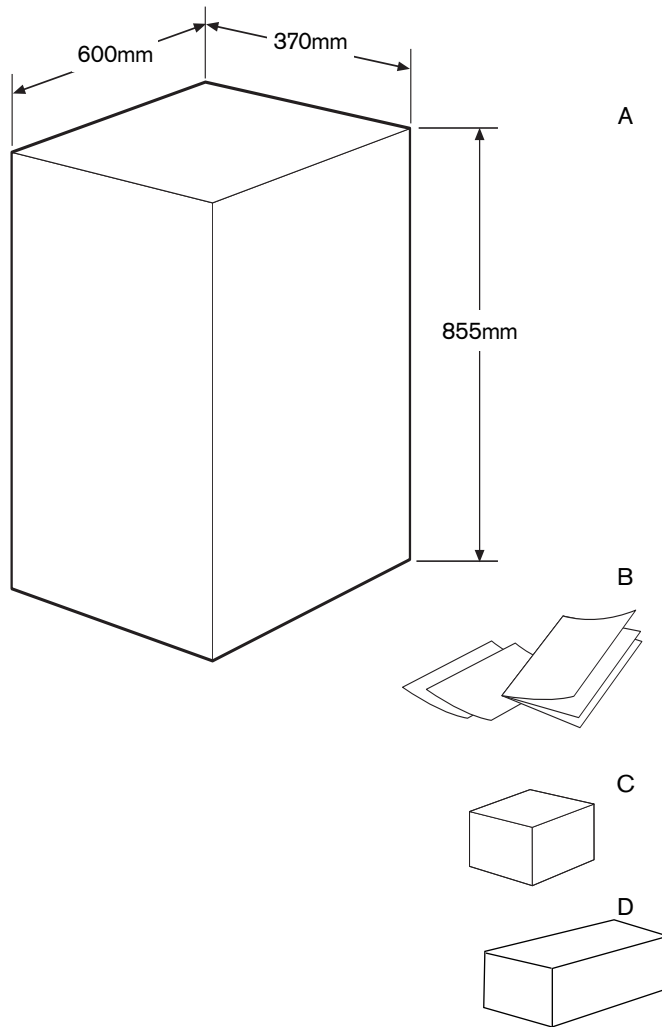

Check List

Item	Qty
Greenstar Camray Utility & Utility System Installation/Serviceing Instructions.....	1
Users Instructions	1
Warranty Return Envelope	1
Guarantee Registration Card.....	1
Condensate Trap Kit.....	1
Return Pipe Kit.....	1

TECHNICAL DATA

DESCRIPTION	UNITS	12/18	18/25	25/32
Central Heating				
Primary water capacity (total) Utility	litres	23	23	21
Primary water capacity (total) Utility System	litres	30	30	28
Maximum static head	metres	30	30	30
Minimum static head	metres	1	1	1
Water side resistance (20°C difference) Utility	mbar	26	52	69
Max. available pumphead (20° difference) Utility System	mH ₂ O	5.7	4.9	4.1
Max. permissible sealed system operating pressure in accordance with WRAS guidelines	bar	2.5	2.5	2.5
Flue				
Exit flue gas mass flow	kg/hr	29	40	51
Pipework connections				
Fuel line (compression)	mm	10	10	10
Utility System flow	mm	22	22	28
Utility flow/optional vent	BSP	1	1	1 ¹ / ₄
Primary drain	BSP	3/4	3/4	3/4
Condensate (polypropylene)	mm	21.5	21.5	21.5
Pressure relief valve outlet - Utility System	mm	15	15	15
Electrical				
Electrical power supply voltage	AC...V	230	230	230
Frequency	Hz	50	50	50
Max. power consumption Utility	W	150	160	160
Max. power consumption Utility System	W	255	265	265
Thermostats				
Boiler flow temperature range (cut in/cut out)	°C	55/81	55/81	55/81
Control thermostat differential	°C	5	5	5
Boiler high limit thermostat set point	°C	95	95	95
Boiler manual reset overheat thermostat set point	°C	105	105	105
Flue manual reset overheat thermostat set point	°C	110	110	110
General Data				
Maximum hearth temperature	°C	<100	<100	<100
SEDBUK (Band A)	%	93.1	93.2	94.2
Appliance protection rating	IP	20	20	20
Weight (excluding packaging) Utility	kg	101	103	110
Weight (excluding packaging) Utility System	kg	109	111	118
Emissions class for NO _x and CO	class	3	3	3

UTILITY

The diagram opposite excludes the top, front and RH side casing panels.

- 1 CONTROL BOX ASSEMBLY
- 2 CASING SIDE PANEL
- 3 FLUE GAS SAMPLING POINT
- 4 FLUE MANIFOLD ACCESS COVER
- 5 FLUE OVERHEAT THERMOSTAT PHIAL
- 6 POWER CABLE CLIP
- 7 FIRE VALVE SENSOR CLIP
- 8 AIR INLET CASING
- 9 FLEXIBLE AIR DUCT (CONNECTING TO AIR INTAKE ON BURNER)
- 10 SECONDARY HEAT EXCHANGER BLEED POINT (ONE ON EITHER SIDE)
- 11 SECONDARY HEAT EXCHANGER
- 12 SECONDARY HEAT EXCHANGER DRAIN
- 13 CONDENSATE OUTLET
- 14 BAFFLE RETAINER ACCESS DOOR
- 15 HEAT EXCHANGER FLOW PIPE
- 16 CONTROL & MANUAL RESET OVERHEAT THERMOSTAT PHIAL
- 17 AUTO-RESET HIGH LIMIT THERMOSTAT PHIAL
- 18 PRIMARY HEAT EXCHANGER
- 19 COMBUSTION CHAMBER ACCESS DOOR
- 20 BASE PLATE AND OIL DRIP TRAY
- 21 BURNER AIR INTAKE (CONNECTED BY FLEXIBLE DUCT (9) TO AIR INLET CASING (8))
- 22 BURNER MOTOR (BEHIND PLASTIC COVER)
- 23 OIL PUMP (BEHIND PLASTIC COVER)
- 24 LOCKOUT RESET BUTTON (ON FRONT OF BURNER CONTROL BOX)
- 25 BURNER CONTROL BOX (BEHIND PLASTIC COVER)
- 26 RIELLO RDB BURNER
- 27 OIL SUPPLY ISOLATING VALVE
- 28 DEFLECTOR PLATE
- 29 BOILER OVERHEAT RESET BUTTON
- 30 FLUE OVERHEAT RESET BUTTON
- 31 TEMPERATURE CONTROL KNOB

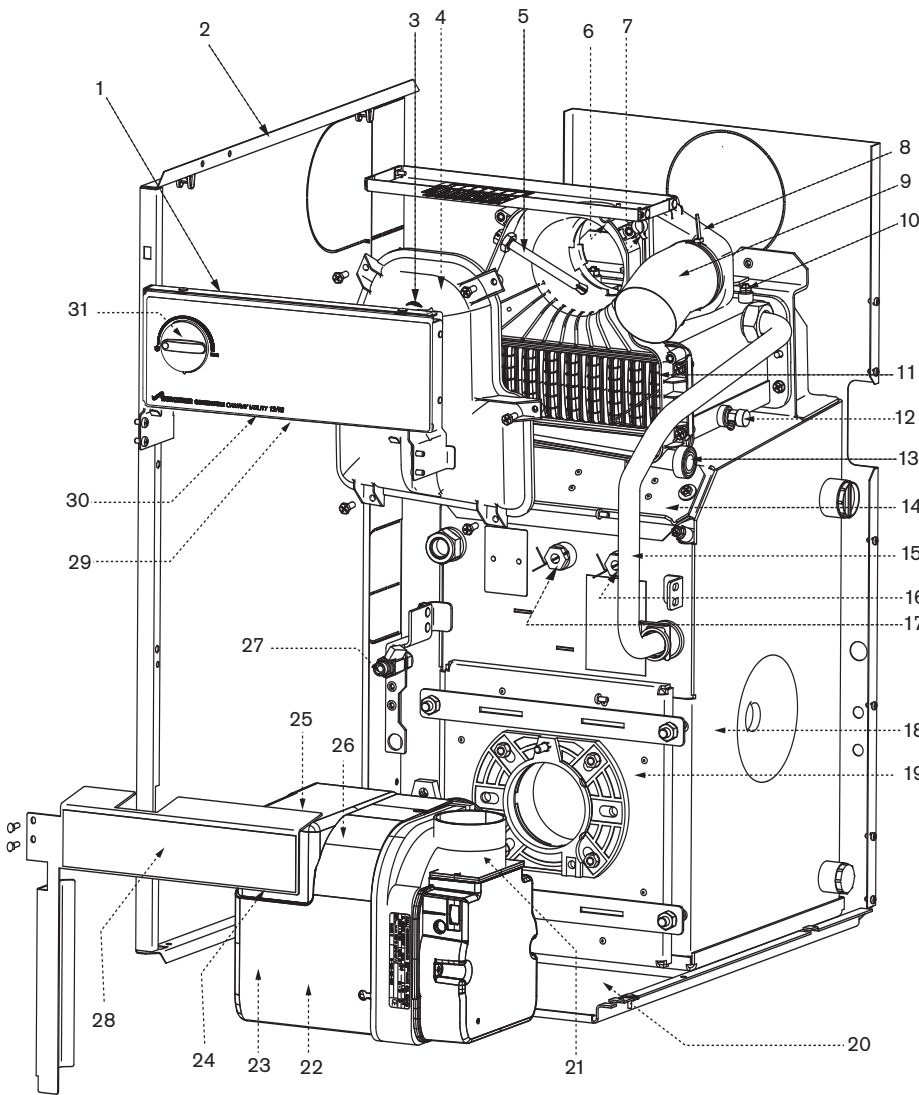

APPLIANCE INFORMATION

UTILITY SYSTEM

The diagram opposite excludes the top, front and RH side casing panels.

- 1 CONTROL BOX ASSEMBLY
- 2 CASING SIDE PANEL
- 3 FLUE GAS SAMPLING POINT
- 4 FLUE MANIFOLD ACCESS COVER
- 5 FLUE OVERHEAT THERMOSTAT PHIAL
- 6 POWER CABLE CLIP
- 7 FIRE VALVE SENSOR CLIP
- 8 AIR INLET CASING
- 9 FLEXIBLE AIR DUCT (CONNECTING TO AIR INTAKE ON BURNER)
- 10 SECONDARY HEAT EXCHANGER BLEED POINT (ONE ON EITHER SIDE)
- 11 SECONDARY HEAT EXCHANGER
- 12 SECONDARY HEAT EXCHANGER DRAIN
- 13 CONDENSATE OUTLET
- 14 BAFFLE RETAINER ACCESS DOOR
- 15 AUTO-RESET HIGH LIMIT THERMOSTAT PHIAL
- 16 HEAT EXCHANGER FLOW PIPE
- 17 CONTROL & MANUAL RESET OVERHEAT THERMOSTAT PHIAL
- 18 CIRCULATING PUMP
- 19 PRIMARY HEAT EXCHANGER
- 20 COMBUSTION CHAMBER ACCESS DOOR
- 21 BASE PLATE AND OIL DRIP TRAY
- 22 BURNER AIR INTAKE (CONNECTED BY FLEXIBLE DUCT (9) TO AIR INLET CASING (8))
- 23 BURNER MOTOR (BEHIND PLASTIC COVER)
- 24 OIL PUMP (BEHIND PLASTIC COVER)
- 25 LOCKOUT RESET BUTTON (ON FRONT OF BURNER CONTROL BOX)
- 26 EXPANSION VESSEL BRACKET
- 27 BURNER CONTROL BOX (BEHIND PLASTIC COVER)
- 28 DEFLECTOR PLATE
- 29 RIELLO RDB BURNER
- 30 EXPANSION VESSEL
- 31 SYSTEM PRESSURE GAUGE
- 32 PRESSURE RELIEF VALVE
- 33 BOILER OVERHEAT RESET BUTTON
- 34 FLUE OVERHEAT RESET BUTTON
- 35 TEMPERATURE CONTROL KNOB

NOTE: OIL SUPPLY ISOLATING VALVE LOCATION IS ILLUSTRATED ON PREVIOUS PAGE ITEM 27.

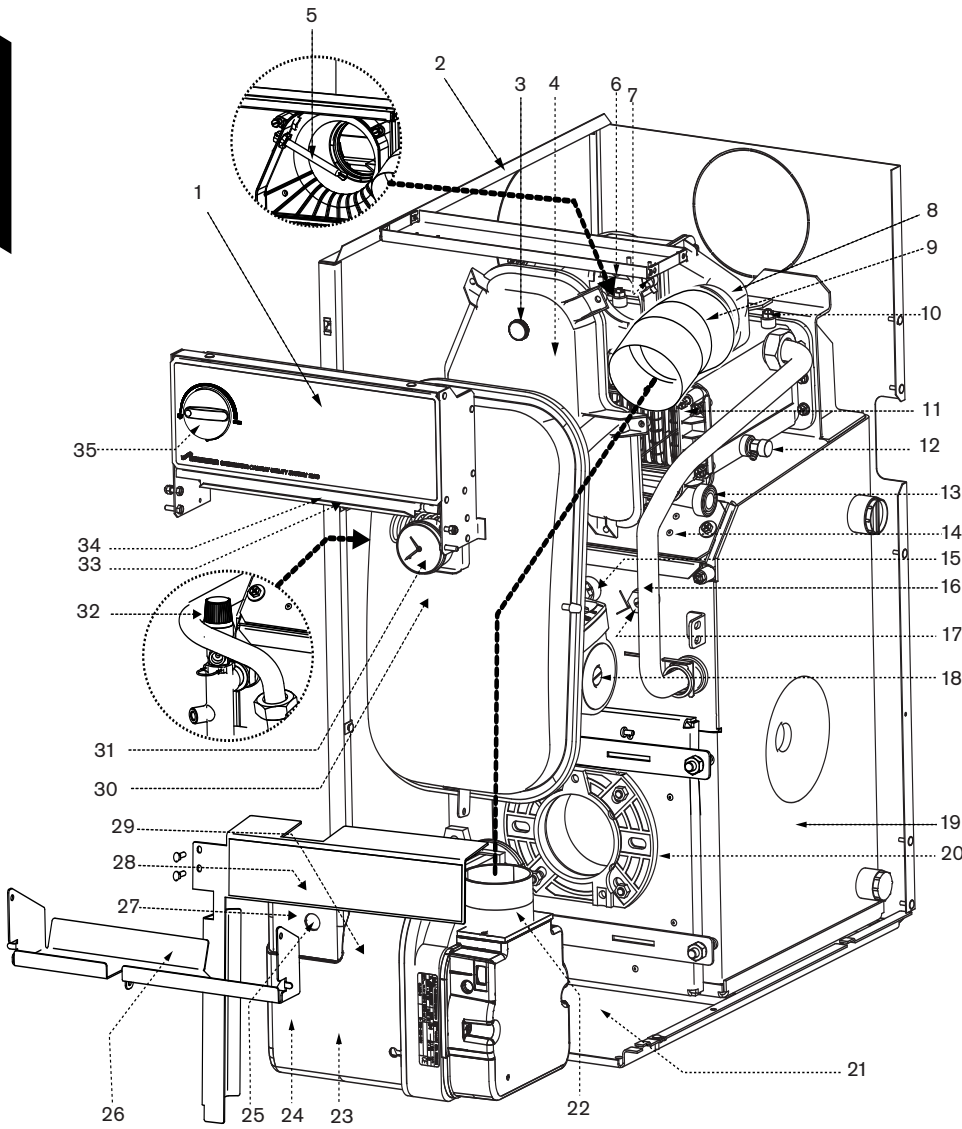

PRE -
INSTALLATION

IMPORTANT: All the following Pre-Installation sections must be read and requirements met before starting boiler or flue installation.

CAUTION: ISOLATE THE MAINS SUPPLIES BEFORE STARTING ANY WORK AND OBSERVE ALL RELEVANT SAFETY PRECAUTIONS.

CLEANING PRIMARY SYSTEMS

IMPORTANT: Debris from the system can damage the boiler and reduce efficiency. Failure to comply with the guidelines for the use of water treatment with the appliance will invalidate the appliance warranty.

BEFORE CLEANING THE SYSTEM:
ENSURE THE SYSTEM AND PIPEWORK IS IN GOOD WORKING ORDER.

FLUSH THE EXISTING SYSTEM WITH A POWER FLUSHING MACHINE OR WITH A CHEMICAL CLEANER BEFORE INSTALLING NEW COMPONENTS.

CLEANING THE PRIMARY SYSTEM:

- ▶ Cleanse the system in accordance with BS 7593.
- ▶ Fill the system with cold mains water to the recommended pressure and check for leaks.
- ▶ Open all drain cocks and drain the system.
- ▶ Close drain cocks and add a suitable flushing agent at the correct strength for the system condition in accordance with the manufacturer's instructions.
- ▶ Circulate the flushing agent before the boiler is fired up.
- ▶ Run the boiler and system at normal operating temperature in accordance with the manufacturer's instructions.
- ▶ Drain and thoroughly flush the system to remove the flushing agent and any debris.



ELECTRIC SUPPLY:

- Supply: 230V - 50Hz.
- Cable: PVC insulated 0.75mm² (24 x 0.2mm) temperature rated to 90°C.
- Protection IP20.
- External 5A fuse to BS1362.
- The appliance must be earthed.
- All pipes to the boiler must be cross-bonded.
- It must be possible to isolate the appliance from the electric supply with at least a 3mm contact separation in both poles supplying the appliance.
- Wiring between the appliance and the electrical supply must comply with IEE wiring regulations and any local regulations which may apply for fixed wiring to a stationary appliance.
- Any system connected to the boiler must not have a separate electrical supply.

- A - Oil storage tank.
- B - Isolating valve.
- C - Oil strainer & water separator.
- D - Fire valve to BS 5410.
- E - External wall.
- F - Fire valve sensor.
- G - Oil burner.
- H - Oil supply pipe.
- J - Oil pump.
- K - Full base (plastic tanks).
- L - Non-return valve.
- M - De-aerator.
- N - Oil filter (16µm max filtration size)

NOTE: All dimensions are in metres unless stated otherwise.

The maximum pipe run figures are based on using copper pipe with an inside diameter of 2mm less than the Ø.

OIL SUPPLY

OIL SUPPLY :

- This appliance is suitable for 28 second kerosene only, no other fuel must be used.
- Plastic or steel tanks should be installed to BS 5410. A steel tank should conform to BS 799: part 5 and have a slope of 1 in 24 away from the outlet valve with a sludge cock at its lower end.
- Do not use galvanised steel tanks or pipework for the oil supply system.
- Do not use soldered joints on the oil supply pipework.

a) Single pipe gravity feed system:

The oil storage tank (A) must be positioned so that the oil level does not exceed 4 metres above the level of the burner oil pump (J) and in addition the oil level must be at least 300mm above the oil pump (J). Where the maximum oil level in the oil storage tank exceeds 4 metres, a head breaking device must be installed between the tank (A) and the burner oil pump (J).

b) Double pipe sub-gravity feed system:

Maximum suction height 3.5 metres. Non-return valves must be fitted to the inlet and return oil line between the oil pump (J) and oil storage tank (A).

c) Single pipe suction lift with de-aerator

Maximum suction height 3.5 metres. The oil tank (A) must be positioned below the oil pump (J). Create an inlet and return loop between the de-aerator (M) and oil pump (J).

A non-return valve must be incorporated within the de-aerator or fitted to the oil line between the oil storage tank (A) and the de-aerator (M).

A top feed oil tank fitted with a de-aerator using an internal non-return valve should have any non-return valves fitted in the base of the tank to the suction line removed to assist purging air from the oil line.

Pipework

- ▶ Use copper pipe of the correct diameter according to the information shown opposite. Use flexible hoses to connect to the oil pump (J).
- ▶ Lay the oil supply pipe (H) as straight and level as possible to avoid air pockets and unnecessary friction losses. Route away from the boiler access door or other hot surfaces.
- ▶ Install a manual isolating valve (B) to the oil supply pipe (H), as close to the oil storage tank (A) as possible.
- ▶ Fit an oil strainer and water separator (C) to the oil supply pipe, near the oil storage tank. Fit an additional oil filter (N, 16µm max filtration size) close to the boiler, but not inside the boiler casing.
- ▶ Fit a fire valve in accordance with BS 5410. The fire valve (D) should be fitted externally to the building with the fire valve sensor (F) located within the appliance case. A fire valve with a shut off temperature of 85°C or higher is recommended to avoid the possibility of nuisance shut offs. A capillary type valve provides a neat and simple installation. Alternatively, a fusible link or electrical system may be used.

Under no circumstances should a combination isolating/fire valve be used as the sole fire protection device.

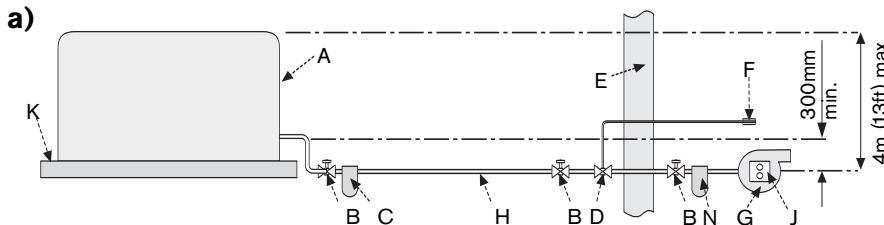

MAXIMUM PIPE RUN FOR SINGLE PIPE GRAVITY FEED SYSTEM

HEAD	10mmØ	12mmØ	HEAD	10mmØ	12mmØ
0.5	12	30	2.5	62	100
1.0	25	69	3.0	74	100
1.5	37	91	3.5	87	100
2.0	49	100	4.0	99	100

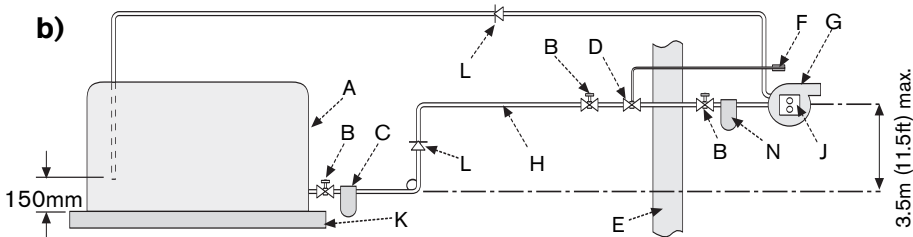

MAXIMUM PIPE RUN FOR DOUBLE PIPE SUB-GRAVITY FEED SYSTEM

HEAD	10mmØ	12mmØ	HEAD	10mmØ	12mmØ
0	50	100	2.0	26	66
0.5	44	100	2.5	20	50
1.0	38	95	3.0	14	37
1.5	32	80	3.5	8	22

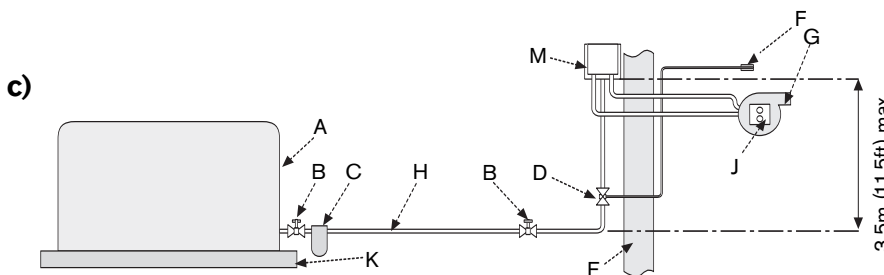

MAXIMUM PIPE RUN FOR SINGLE PIPE SUCTION LIFT WITH DE-AERATOR

HEAD	FUEL FLOW RATE				HEAD	FUEL FLOW RATE			
	2.5kg/h 8mmØ	5kg/h 8mmØ	10kg/h 8mmØ	10kg/h 10mmØ		2.5kg/h 8mmØ	5kg/h 8mmØ	10kg/h 8mmØ	10kg/h 10mmØ
0	100	55	26	100	2.0	60	30	14	65
0.5	95	45	23	100	2.5	45	25	11	50
1.0	80	40	20	90	3.0	35	15	8	35
1.5	70	35	17	75	3.5	25	10	5	20

The table and illustration above is a guide only and does not in any way override the de-aerator manufacturers instructions.

IMPORTANT: The boiler should not be allowed to operate with a return temperature of less than 40°C when the system is up to operating temperature.

TYPICAL OPEN VENT SYSTEM:

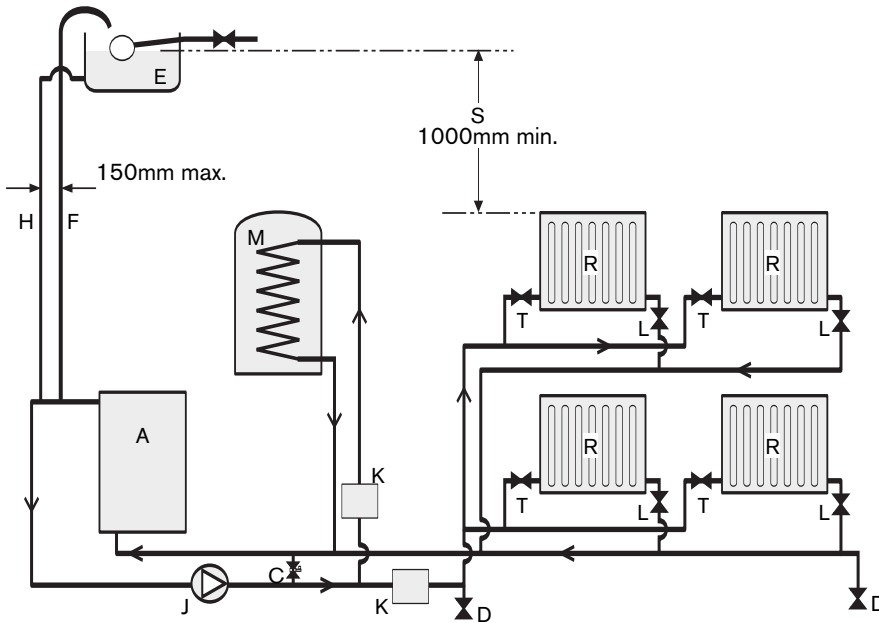

- A - Appliance.
- B - Expansion vessel.
- C - Automatic bypass valve.
- D - Drain cock.
- E - Feed and expansion cistern.
- F - Feed and expansion 15mmØ min.
- G - Pressure gauge.
- H - Open vent 22mmØ min.
- J - Circulating pump.
- K - Zone valve.
- M - Hot water cylinder.
- N - Automatic air vent.
- P - Pressure relief discharge.
- R - Radiators.
- S - Static head.
- T - Thermostatic radiator valve (TRV).
- U - To filling system.

TYPICAL SEALED SYSTEM:

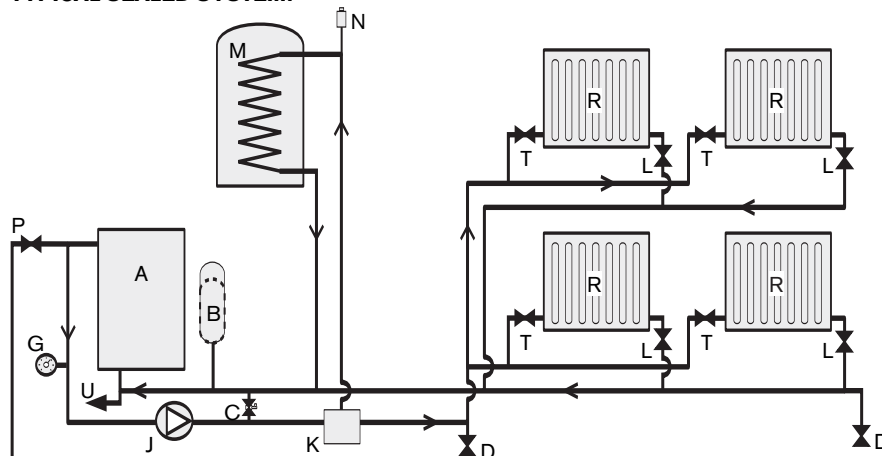

PRIMARY SYSTEM PLASTIC PIPEWORK:

- Do not use plastic pipework on sealed systems, *apart from underfloor heating correctly installed as detailed below.
- Any plastic pipework used on an open vented system must have a polymeric barrier with 1000mm (minimum) length of copper or steel pipe connected to the boiler.
- * Plastic pipework used for underfloor heating must be correctly controlled with a thermostatic blending valve limiting the temperature of the circuits to approx. 50°C. The pipework from the boiler to the blending valve must be in copper or steel (protected from corrosion).

PRIMARY SYSTEM/CONNECTIONS/VALVES:

- Do not use galvanised pipes or radiators.
- All system connections, taps and mixing valves must be capable of sustaining a pressure of 3 bar.
- Radiator valves should conform to BS 2767:10.
- All other valves should conform to BS 1010.
- On new installations TRVs must be used on all radiators except the radiator where the room thermostat is sited, this must be fitted with lockshield valves and left open. All installations should have TRVs fitted to radiators within the sleeping accommodation.
- An automatic bypass valve must be connected between the heating flow and return where TRVs are used on all radiators, fitted to give at least a 3 metre circuit when activated.
- Drain cocks are required at all the lowest points on the system.
- Air vents are required at all high points on the system.

OPEN VENT PRIMARY SYSTEM

- **Utility System models:** The feed and expansion pipe (F) and the open vent pipe (H), (or the combined feed and vent pipe), must be connected to the BSP outlet/s on the side of the primary heat exchanger.
- The feed and expansion cistern (E) must be positioned to provide a static head (S) of at least 1 metre above the highest point in the heating system to the water level in the feed and expansion cistern (E).
- No valve shall be fitted in the open vent pipe (H) or the feed and expansion pipe (F).
- The open vent pipe (H) must be at least 22mmØ.

FULLY PUMPED SEALED PRIMARY SYSTEM

- Utility System models:**
- A pressure relief valve (P), spring loaded safety valve set to operate at 3bar, must be fitted to the heating flow pipe as close as possible to the boiler or onto one of the boiler top 1" / 1 1/4" BSP outlets.
 - An expansion vessel (B) must be fitted to the heating return pipe as close as possible to the boiler and pressurised for the system volume according to the instructions supplied with the vessel.
 - A pressure gauge (G), 3 bar minimum, must be fitted to the heating flow pipe or one of the boiler 1" / 1 1/4" BSP outlets.
 - An automatic air vent (N) must be fitted (all models).

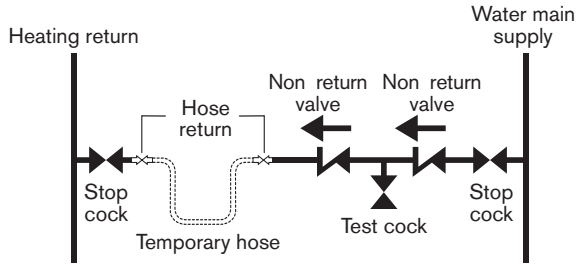

FILLING PRIMARY SEALED SYSTEMS:

- Filling the system must comply with one of the methods shown opposite.
- The filling point must be at low level and must never be a permanent direct fixing to the mains water supply.
- Filling loops must be WRAS approved.

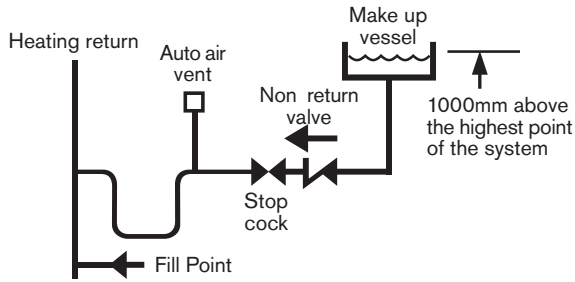

PRE -
INSTALLATION

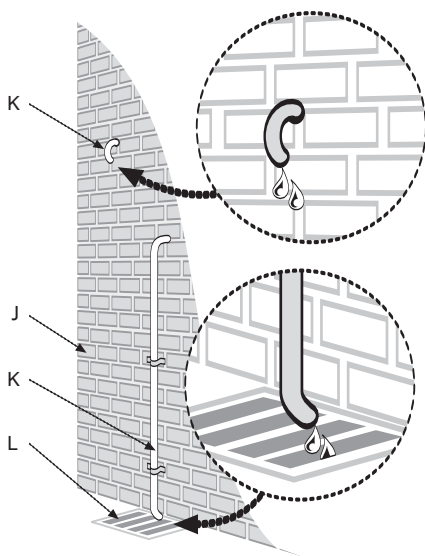
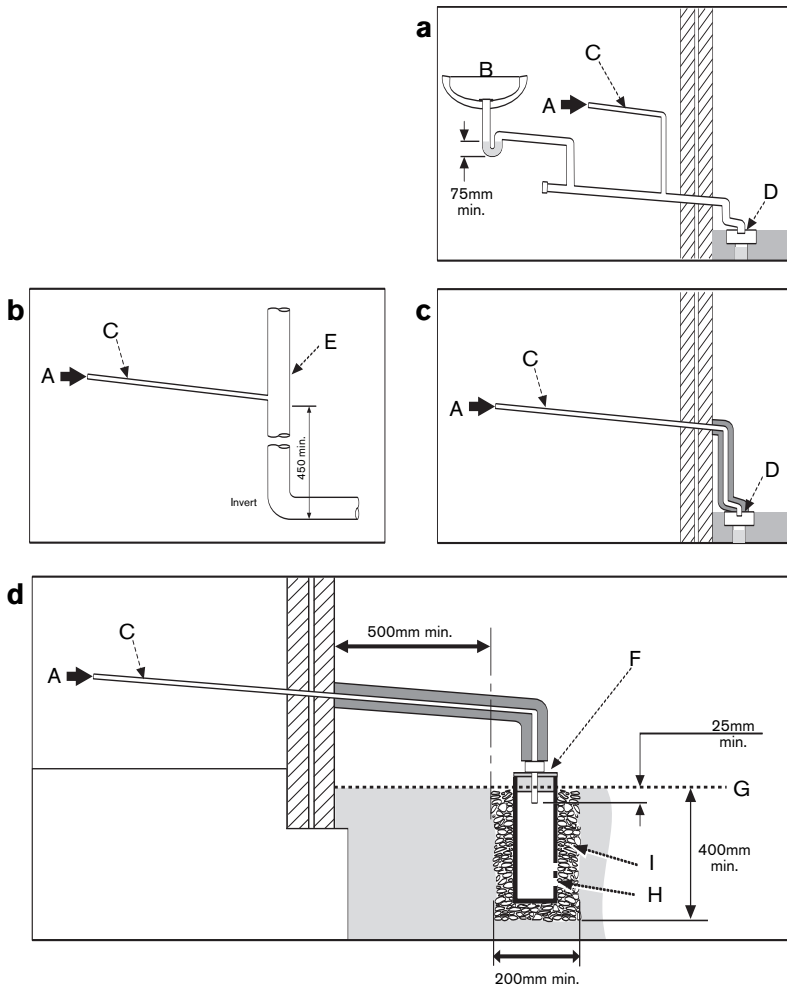

CONDENSATE &

PRESSURE RELIEF PIPEWORK

CONDENSATE PIPEWORK:

- All national and, where appropriate, local regulations for the discharge and neutralisation of condensate should be followed.
- The condensate pipe must be a minimum of 21.5mmØ polypropylene pipe.
- The condensate pipework must fall at least 50mm per metre towards the outlet and should take the shortest practicable route and not exceed 3 metres outside the building. If a run greater than 3m is required, 32mmØ polypropylene pipe must be used.
- The pipework must follow one of the options shown opposite:

a - Internal waste drainage system

b - Soil/vent stack

c - External drainage system

d - External condensate absorption point

- Use waterproof pipe insulation in exposed positions and for external pipework

IMPORTANT: Condensate pipework must not leak and the condensate trap must be filled with water before the boiler is started to prevent the possibility of potentially harmful flue products escaping via the condensate route.

- A - Condensate from the boiler condensate trap (supplied) which has a 75mm minimum water seal.
- B - Sink.
- C - 21.5mm Ø polypropylene condensate pipe.
- D - Gully.
- E - Internal soil and vent stack.
- F - 300mm x 100mm Ø sealed plastic tube.
- G - Ground level.
- H - Drainage holes 50mm from base of tube (12mm Ø at 25mm centres) facing away from building.
- I - Limestone chippings.

PRESSURE RELIEF PIPEWORK:

IMPORTANT: The pressure relief valve is a safety device for the boiler and if activated may discharge boiling water or steam through the relief valve drain pipe. Care should be taken when siting the outlet pipe so that it does not cause an obstruction or discharge above a window, entrance or other public access where it could cause a hazard.

- The pressure relief drain pipe (K) should be at least 15mm diameter copper pipe and run downwards away from the boiler and discharge away from any electrics or other hazard, preferably to an external drain or soakaway.
- Pipe (K) should be finished with a partial bend, near the outlet to face the external wall (as shown) to help prevent freezing.

J - Outside wall.

K - Drain pipe.

L - External drain.

a: RECOMMENDED INSTALLATION CLEARANCES

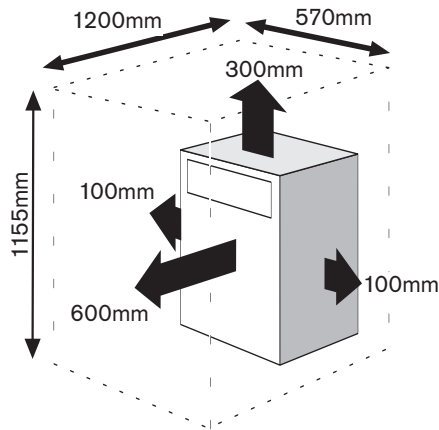

b: ANNUAL SERVICE CLEARANCES

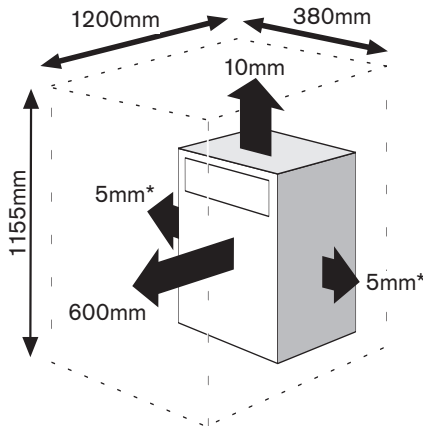

c: MAINTENANCE & REPAIR CLEARANCES

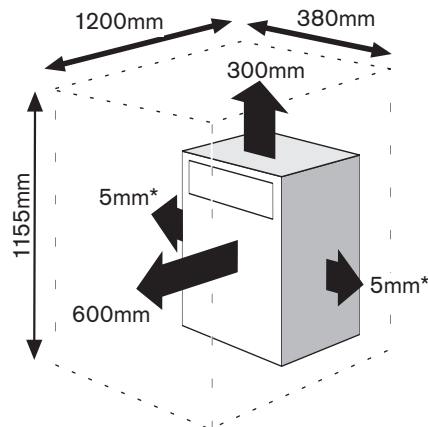

* Remove the flue 'knock-out' panel sections if this clearance is less than 75mm.

MINIMUM AIR VENT AREA (cm²) FOR APPLIANCES INSTALLED IN A COMPARTMENT:

¹Internal air to and from a space/room inside the building. ²External air to and from directly outside the building.

Conventional flue:

Model	Internal ¹ ventilation		External ² ventilation	
	High Level	Low Level	High Level	Low Level
12/18	143	214	72	143
18/25	220	330	110	220
25/32	275	413	138	275

Room Sealed flue:

Model	Internal ¹ ventilation		External ² ventilation	
	High Level	Low Level	High Level	Low Level
12/18	143	143	72	72
18/25	220	220	110	110
25/32	275	275	138	138

BOILER LOCATION &

CLEARANCES

- This boiler is only suitable for installing internally within a property at a suitable location onto a fixed rigid surface of the same size as the boiler and capable of supporting the boiler weight.
- The boiler must be installed on a flat level surface to ensure condensate does not enter the primary heat exchanger.
- The boiler is not suitable for external installation unless a suitable enclosure is provided.
- Roof space installations must fully conform to BS5410 part 1 section 4.6.9.

Open flue model (CF):

- In order to ensure clean and efficient combustion an adequate supply of air must be delivered to the combustion chamber.
- To provide sufficient air a suitable inlet must be provided into the room or space in which the boiler is situated.

CF minimum air inlet sizes

Model	12/18	18/25	25/32
Size cm ²	72	110	138

An air brick or other form of continuous air supply may have to be built into the installation in order to ensure an adequate supply of air.

- If the appliance is to be installed in a confined space or compartment two air vents are required, one at high level and one at low level. The minimum free area of each vent is shown opposite and depends whether the air is taken from another room or from outside the building.

- Where the air is taken from another room that room must contain an air inlet as described above.

Room sealed balanced flue model (RS):

The appliance does not require a separate vent for combustion air.

- Installation in cupboards or compartments require permanent vents for cooling purposes, one at high level and one at low level, either direct to outside air or to a room.
- Both vents must pass to the same room or be on the same wall to the outside air.

The minimum air vent free area is given in the table opposite.

a: INSTALLATION CLEARANCES:

Diagram (a) shows the minimum space recommended to install the boiler only.

b: ANNUAL SERVICE CLEARANCES:

Diagram (b) shows the minimum space required to carry out an annual service.

c: MAINTENANCE & REPAIR CLEARANCES:

Diagram (c) shows the minimum space required for maintenance and repair to the boiler. The appliance is suitable for an under worktop installation providing that the worktop above the boiler (min.10mm clearance) is removable for maintenance and repair and the front of the boiler is not enclosed.

BOILER LOCATION &

CLEARANCES

COMPARTMENTS:

Follow the requirements of BS 5410 and note:

- Minimum clearances must be maintained.
- An access door is required to install, service and maintain the boiler and any ancillary equipment.
- If fitting the boiler into an airing cupboard use a non-combustible material (if perforated, maximum hole sizes of 13mm) to separate the boiler from the airing space.

Venting compartments:

There must be sufficient clearance around the appliance to allow proper circulation of ventilation air. The clearances required for installation and servicing will normally be adequate for ventilation.

- Ventilation must be provided for boilers fitted into compartments as described in BS 5410.
- Combustion air must not be taken from a room or internal space containing a bath or shower and must not communicate with a protected area such as a hall, stairway, landing, corridor, lobby, shaft etc.
- Air vents must allow access for clean free air and must be sited to comply with the flue terminal position requirements.
- Air ducting runs must not exceed 3m.
- Low level air vents must be less than 450mm from the floor.
- A warning label must be added to the vents with a statement to the effect: "Do not block this vent. Do not use for storage."

SHOWER / BATHROOMS:

The boiler **must not** be installed in zones 0, 1 or 2 (the shaded areas shown on the diagrams opposite).

IMPORTANT: conventional flued boilers must not be fitted in a bathroom.

IMPORTANT: any appliance control using mains electricity must not be able to be touched by a person using the bath or shower. Electrical switches, fused spur and socket outlets must not be fitted in the bathroom. In all cases the IEE wiring regulations must be consulted. All pipework in bathrooms and shower rooms must be cross bonded.

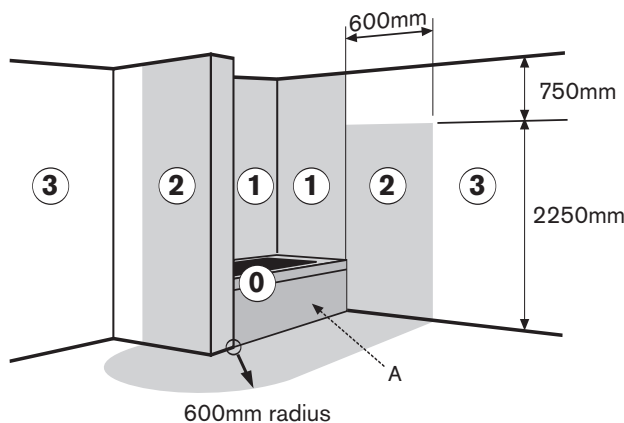
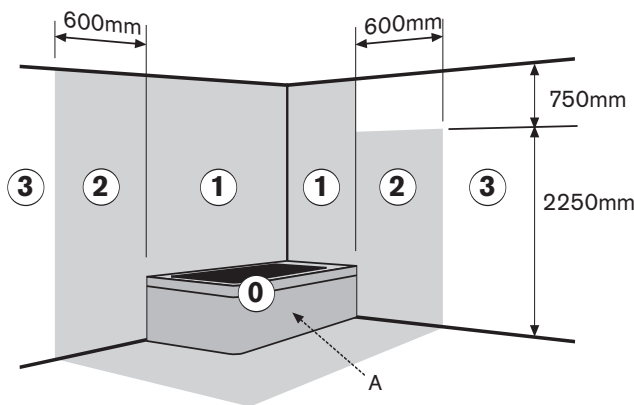

A - Bath or shower cubicle (zone 0)

Minimum dimensions of flue terminal positions for oil-fired appliances:

TERMINAL POSITION	CF	RS(H)	RS(V)
A ^{1,2} Directly below an opening, air brick, opening windows, etc	N/A	600mm	N/A
B ^{1,2} Horizontally to an opening, air brick, opening window, etc	N/A	600mm	N/A
C Below a plastic/painted gutter, drainage pipe or eaves if combustible material protected	N/A	75mm	N/A
D ³ Below a plastic/painted gutter, drainage pipe or eaves without protection to combustible material	N/A	600mm	N/A
E From vertical sanitary pipework	N/A	300mm	N/A
F From an external or internal corner or from a surface or boundary alongside the terminal	N/A	300mm	N/A
G Above ground or balcony level	N/A	300mm*	N/A
H From a surface or boundary facing the terminal	N/A	600mm**	N/A
I From a terminal facing the terminal	—	1200**mm	—
J Vertically from a terminal on the same wall	N/A	1500mm	N/A
K Horizontally from a terminal on the same wall	—	750mm	—
L Above the point of highest intersection with the roof	600mm	—	600mm
M From a vertical structure on the side of the terminal	750mm	—	750mm
N Above a vertical structure less than 750mm from the side of the terminal	600mm	—	600mm
O From a ridge terminal to a vertical structure on the roof	1500mm	—	N/A

— Not applicable

N/A Not allowed

CF Conventional flue

RS(H) Room Sealed Horizontal flue

RS(V) Room Sealed Vertical flue

- 1 An opening means an openable element, such as an openable window, or a permanent opening such as a permanently open air vent.
- 2 Notwithstanding the dimensions above, a terminal should be at least 300mm from combustible material, e.g. a window frame.
- 3 A way of providing protection of combustible material would be to fit a heat shield at least 750mm wide.

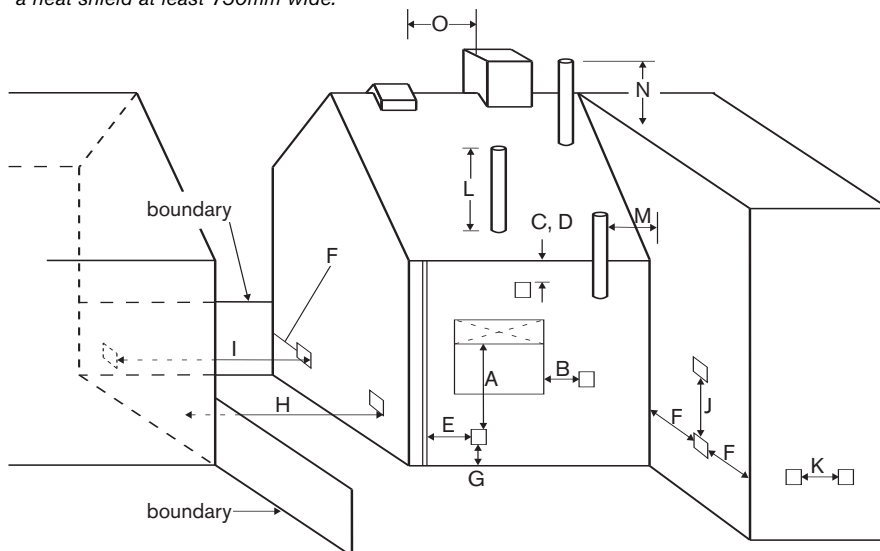
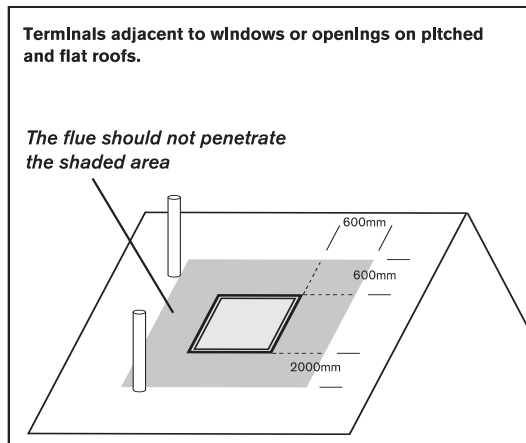

FLUE TERMINAL POSITIONS

- The flue must be fitted and terminated in accordance with the recommendations of BS 5410.
- Flue terminals must be positioned to avoid combustion products entering into buildings.
- The flue must not cause an obstruction.
- Discharge from the flue outlet must not be a nuisance.
- Flue gases have a tendency to plume and in certain weather conditions a white plume of condensation will be discharged from the flue outlet which could be regarded as a nuisance, for example, near security lighting.
- There should be no restriction preventing the clearance of combustion products from the terminal.
- The air inlet/outlet duct and the terminal of the boiler must not be closer than 25mm to any combustible material. Detailed recommendations on protection of combustible materials are given in BS 5410:1
- A protective terminal guard must be fitted if the terminal is 2m or less above a surface where people have access. The guard must be spaced equally (minimum 50mm) around the flue and fixed to the wall with plated screws.

Stainless steel terminal guard:
Part No. 7 716 190 050.

- The following additional guidelines (from part L Exceptions Guidance Document) are recommended when determining the flue outlet position:
- Avoid discharging flue gases into car ports or narrow passageways.
- *Minimum distance of the flue terminal from above ground is 2100mm where directed to a public footpath, private access route or a frequently used area and 2500mm from a car parking area.
- **Minimum distance of the flue terminal to a facing wall, fence, building or property boundary is 2500mm.

PRE-INSTALLATION

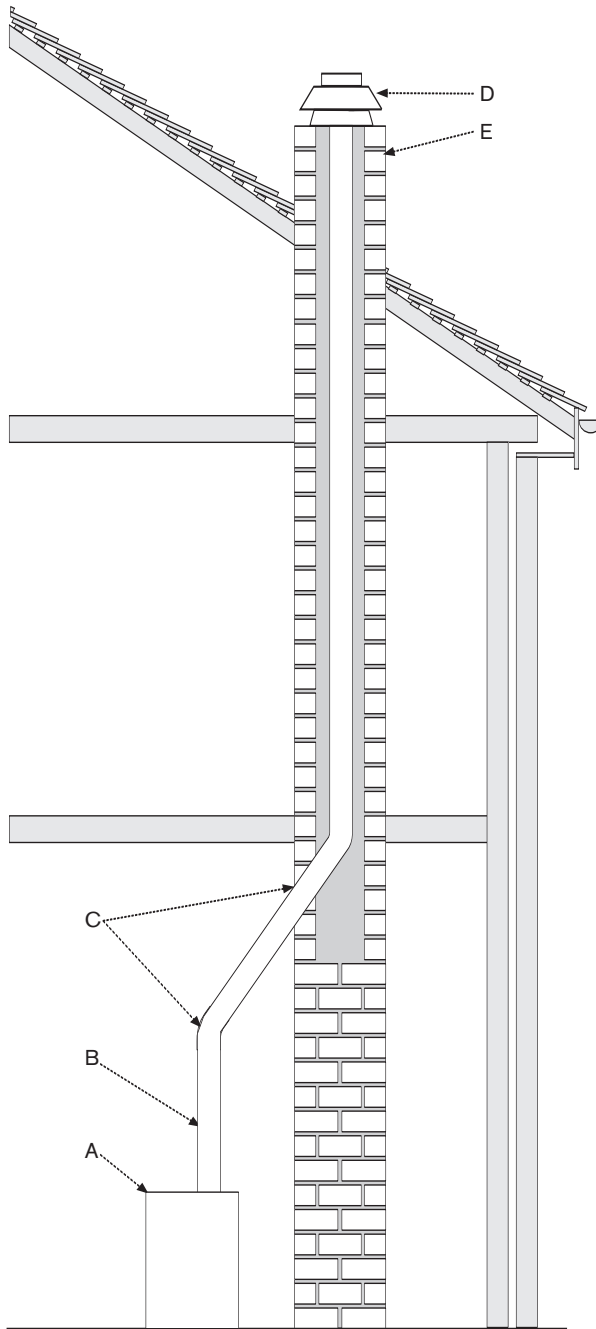

- A - Boiler
- B - Flue
- C - Max. 2 bends at 135°
- D - Anti down-draught terminal
- E - Chimney

- Open (conventional) flued appliances must not be installed in a bedroom, bathroom or bedsitting room.
- The flue system must be in accordance with BS 5410 : Part 1 and the current Building Regulations.
- The flue must be constructed of materials suitable for use with condensing combustion products.
- External flue systems must be of the insulated type.
- Brick and masonry chimneys must be lined with a suitable non-combustible material and properly jointed to withstand the effects of the working temperature (minimum rating of material 120°C) of the appliance and any condensate which may form.
- All flue joints must be sealed to prevent the leakage of condensate and combustion products.
- Ensure that joints are made so that the condensate runs away and is not collected within the joint.

NOTE: The flue can be increased in size from the boiler take off point providing the joint is correctly sealed. Never reduce the flue diameter from the boiler take off point.

CF Sizing:

- 12/18 and 18/25 = 100/103mmØ
- 25/32 = 130mmØ

- Because the flue operates at a lower temperature on a condensing boiler compared to that of a conventional appliance, the flue draught will be lower. Typically the draught will be between 0.5mmwg and 4.4mmwg, measured with the flue warm but the burner not firing. The actual figure will vary depending on weather conditions, flue height and position.
- The flue should be vertical and contain as few bends as possible, a maximum of two 135° bends should be used.
- The flue outlet must be extended beyond the eaves of the building and where possible, above the apex.
- Fit a suitable anti down-draught terminal where down draughts are experienced.

Manufacturers of conventional flue systems suitable for this appliance are listed under 'Contact Information' on the back cover.

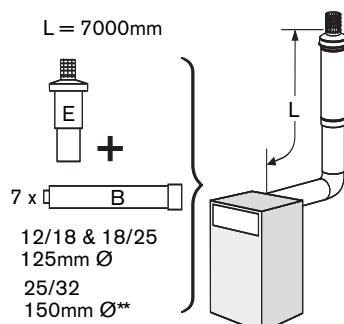
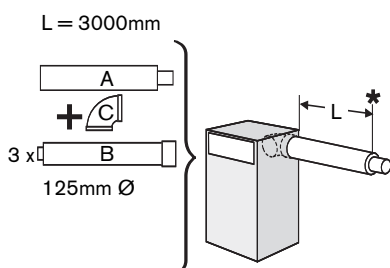
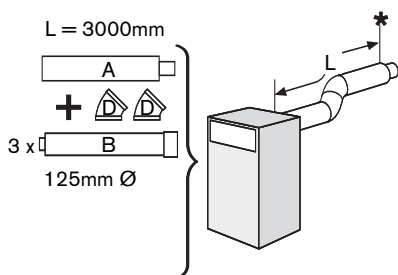
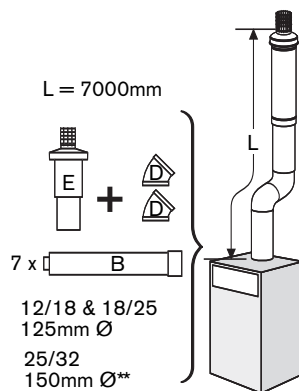
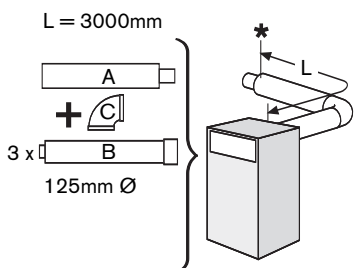
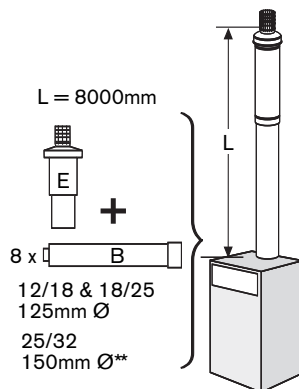
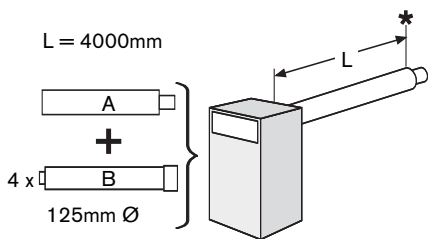
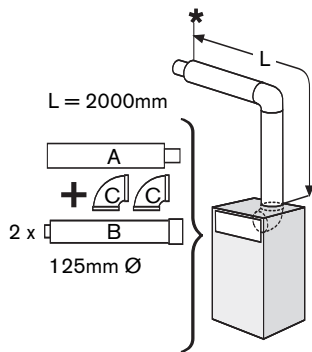
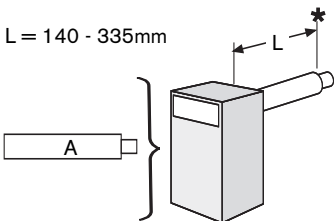

ROOM SEALED FLUE OPTIONS

The diagrams (opposite) show the components used and the maximum flue length (L) for each flue configuration.

In all cases L is measured from the outside of the boiler casing.

- To achieve the maximum flue length (L), a flue section will have to be reduced in length.
- Only the flue terminal or straight flue extensions can be reduced in length by cutting.
- The flue terminal end can be fitted from the inside or outside of the building.

IMPORTANT:

All horizontal sections must rise away from the boiler by 52mm per metre (3°) to allow the condensate to drain back to the boiler.

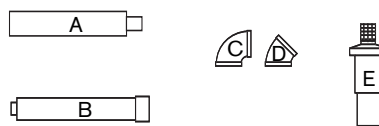

- A - Horizontal terminal
- B - Straight flue extension
- C - Flue bend 90°
- D - Flue bend 45°
- E - Vertical Terminal Kit (incl. 90° elbow)

Calculating the flue length:

Measure the total flue length required, noting that the maximum straight flue length including the terminal is:

Horizontal 80/125mm Ø: 4000mm (excluding 120mm of terminal extending outside the building)

Vertical 80/125mm Ø & 100/150mm Ø: 8000mm (measured from the boiler top panel).

Then reduce the total straight flue length for each extra flue bend (excluding the vertical flue kit 90° elbow) by:

1000mm for 90°

500mm for 45°

Flue Extension lengths:

Horizontal & Vertical 80/125mm Ø: 1000mm overall length.

Effective length when engaged into sockets within the flue run is 950mm.

Flue Terminal lengths:

Horizontal 80/125mm Ø: 720mm

Vertical 80/125mm Ø: 1080mm + cage

Vertical 100/150mm Ø: 1290mm + cage

* to outside wall.

** The 80/125 to 100/150mmØ vertical adaptor must be fitted vertically at the lowest point of the vertical section of the flue. Failure to fit the adaptor vertically will cause the condensate to pool within the flue and will adversely affect the flue's performance.

IMPORTANT: All the previous Pre-Installation sections must be read and requirements met before starting boiler or flue installation.

UNPACKING THE BOILER

LIFTING AND CARRYING PRECAUTIONS:

- Lift only a manageable weight, or ask for help.
- When lifting or putting things down, bend the knees, and keep the back straight and feet apart.
- Do not lift and twist at the same time.
- Lift and carry objects close to the body.
- Wear protective clothing and gloves to protect from any sharp edges.

Unpacking:

It is advised that at least two or more persons are involved in the transfer of the packaged boiler from the van to the point of delivery.

- 1 ▶ Once the packaged boiler has been delivered, the outer carton is removed first. Care should be taken when releasing the straps. If a sharp implement is used make sure the outer carton is not pierced and that the implement is used in such a way so that it may not cause personal injury. All sharp objects must be covered or the blade retracted after use and put away in a safe place.
- 2 ▶ Lift carton up and away from the boiler.
 - ▶ Remove the plastic bag and upper front protection cover from the boiler and place safely aside.
 - ▶ At least two or more persons are required to move the boiler taking care not to damage the boiler, panels or the floor.

At all times the correct method for handling heavy objects should be strictly observed.

1

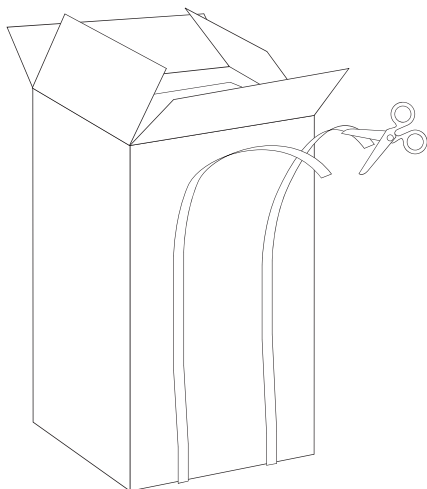

2

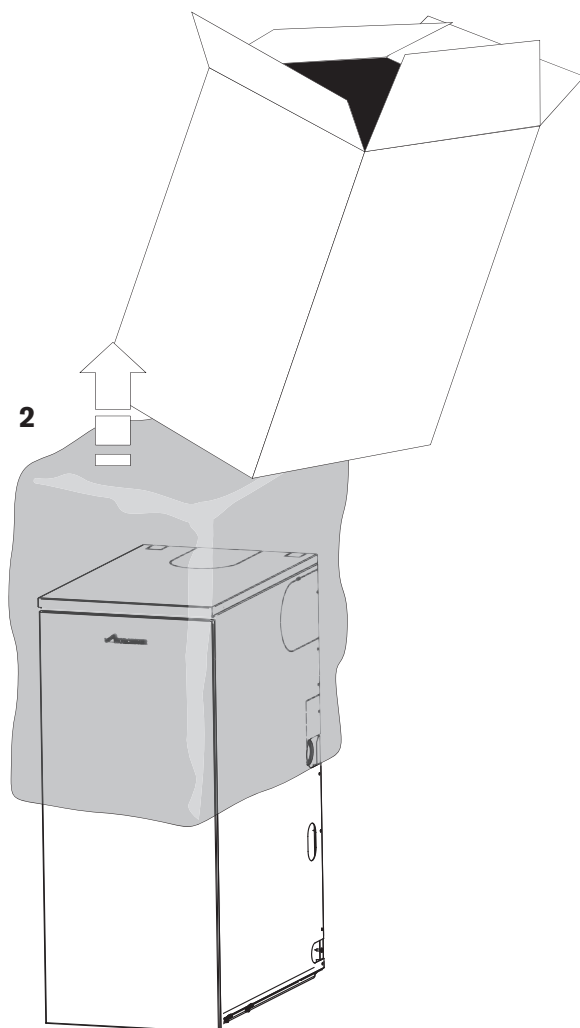

FLUE OPENING

CAUTION: Ensure there are no pipes, electric cables, damp proof courses or other hazards before drilling.

SAFETY:

All relevant safety precautions must be undertaken. Protective clothing, footwear, gloves and safety goggles must be worn as appropriate.

PIPEWORK POSITIONS:

- A - Flow (Utility models only) /open vent 1" BSP 12/18, 18/25.
1 1/4" BSP 25/32.
- B - Primary drain/feed 3/4" BSP.
- C - Return 22mm Ø copper 12/18, 18/25.
28mm Ø copper on 25/32 model.
- D - Condensate outlet 21.5mm Ø.
- E - Flue outlet.
- *Extra pipe outlets, (Utility System only):
- F - Flow 22mm Ø copper 12/18, 18/25 and 28mm Ø copper for 25/32.
- G - Pressure relief pipe 15mm Ø copper.

NOTE: For servicing purposes, keep condensate and pressure relief discharge pipes away from components and pipework connections.

IMPORTANT: The flue and pipework openings are covered with tabbed blanks. Remove carefully as necessary.

FLUE OPENING:

- ▶ Follow the diagram opposite to mark the centre of the flue (1, & 2) for rear opening, (2 & 3) for side opening or (1 & 4) for top opening.

**** IMPORTANT:** for horizontal flues, increase this height by 52mm for every 1000mm of horizontal length that the flue opening is away from the boiler.

NOTE: all horizontal flue sections must rise away from the boiler by 52mm per metre to ensure that condensate flows back into the boiler for safe discharge via the condensate waste pipe.

- ▶ Make an opening (F, G or H) through the wall using a core drill or similar at a size relative to the wall thickness as shown below:

125mm Ø flue:	
Wall thickness	Flue hole size
150 - 240mm	Ø155mm
240 - 330mm	Ø160mm
330 - 420mm	Ø165mm
420 - 500mm	Ø170mm

150mm Ø flue:	
Wall thickness	Flue hole size
150 - 240mm	Ø180mm
240 - 330mm	Ø185mm
330 - 420mm	Ø190mm
420 - 500mm	Ø195mm

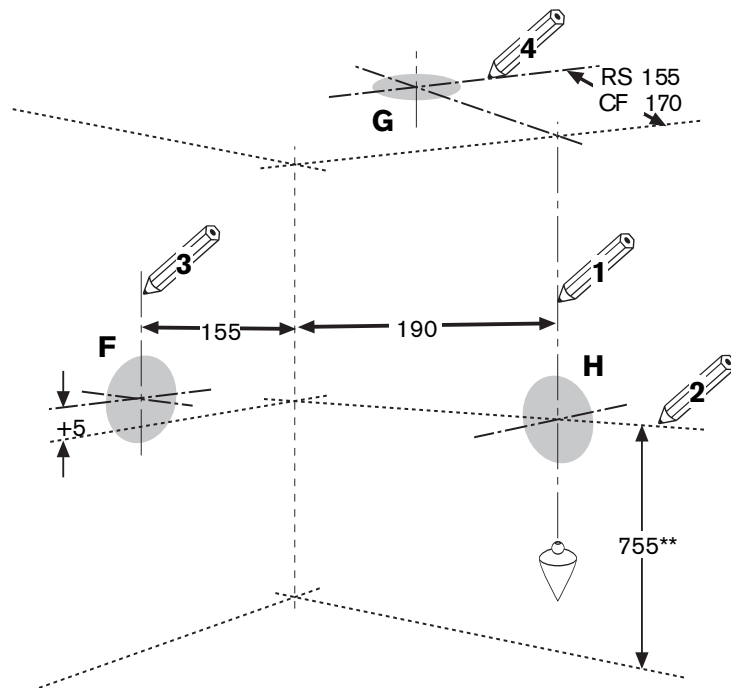
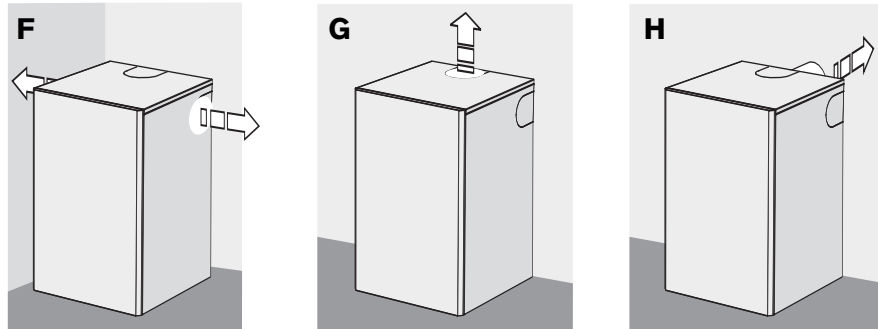
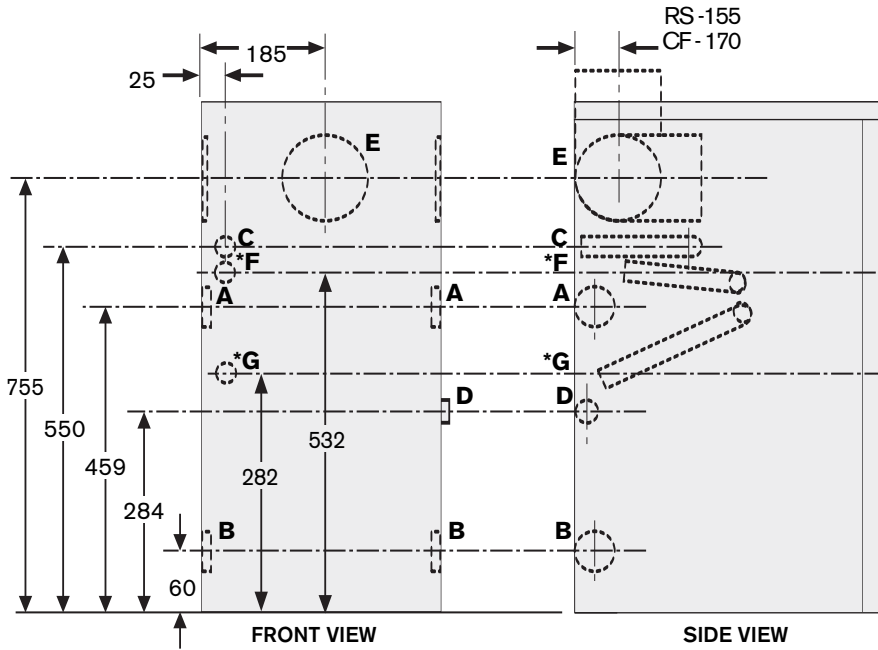

INSTALLATION

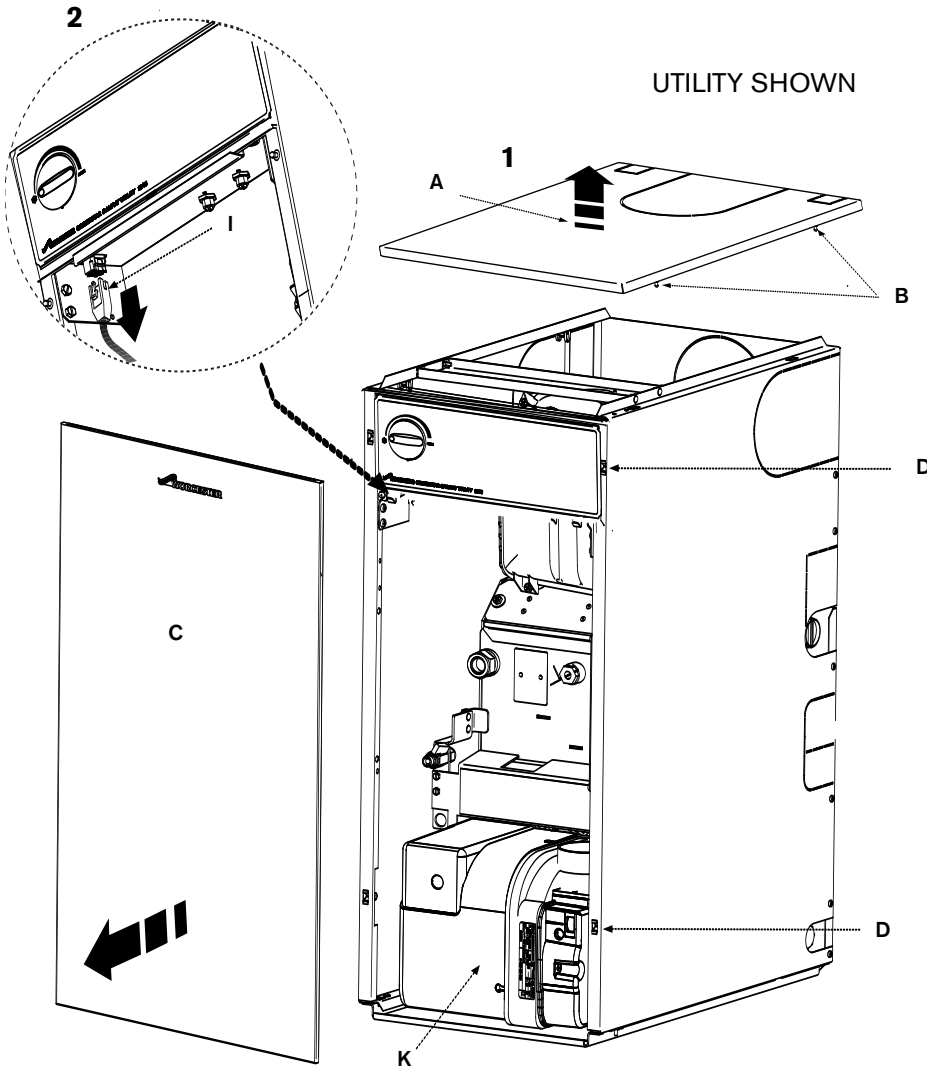

UTILITY SHOWN

(All models):

- 1 ▶ Lift the top panel (A) upwards to disengage the ball stud connections (B) and remove. Pull front panel (C) forward to disengage ball studs from their connections (D).

(Utility system only):

- ▶ In the case of the Utility System boiler, remove the retaining tie at the base of the expansion vessel (E). Loosen the expansion vessel clamping screw (F) and move the vessel to the right to clear the top support. Lift the expansion vessel (G) up and move the base out and slide down to remove. Place the expansion vessel outside of the boiler taking care not to kink or stretch the flexible hose.
- ▶ Remove the securing screws (H) from each side and remove the expansion vessel securing bracket.

(All models):

- 2 ▶ Depress locking ears to unplug burner lead (I) from control box.
- 3 ▶ Unscrew to loosen the retaining ring (J) that secures the flexible air supply tube to the burner (K) and pull the flexible air supply tube free from the burner.
 - ▶ Undo the two screws securing the deflector plate (L) and remove the plate.
 - ▶ Undo and remove the retaining nut (M) on top of the burner. The burner mounting (N) can now be eased off the lug (O) on the burner collar to remove the burner from the heat exchanger. Store the burner and retaining nut safely away from the boiler.
- 4 ▶ Carefully move the boiler into position observing at all times the correct method for handling heavy objects. In the case of the Utility System take care not to damage the expansion vessel.

UTILITY SYSTEM ONLY

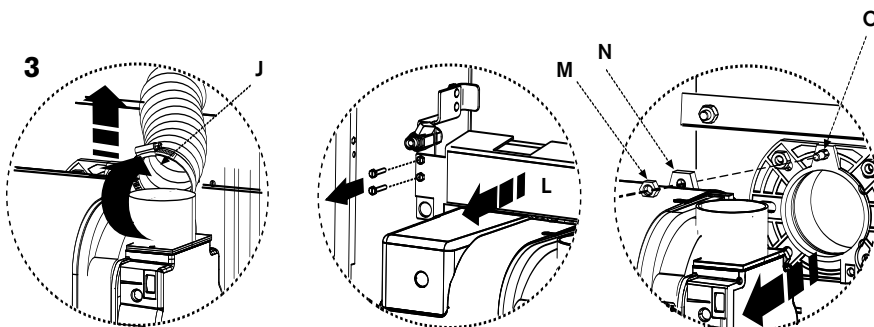
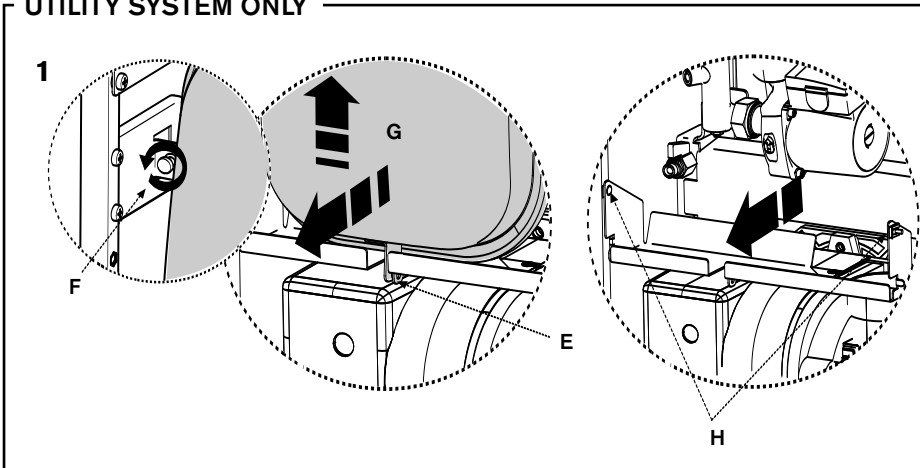

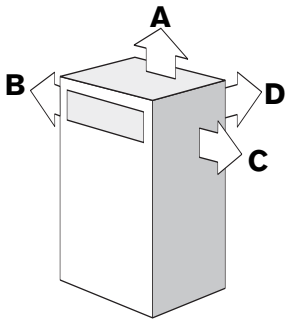

- E - Boiler outer casing
- F - Outer flue tube
- G - Outer/elbow connection
- H - Outside wall/roof
- K - CF adaptor

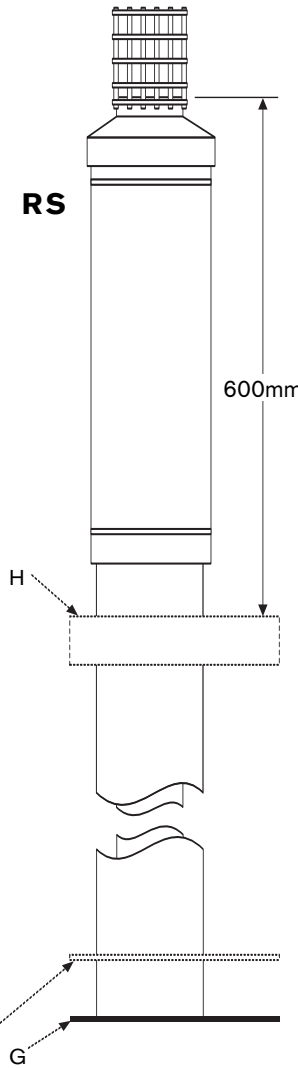
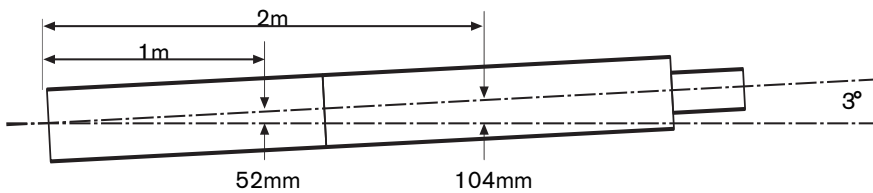
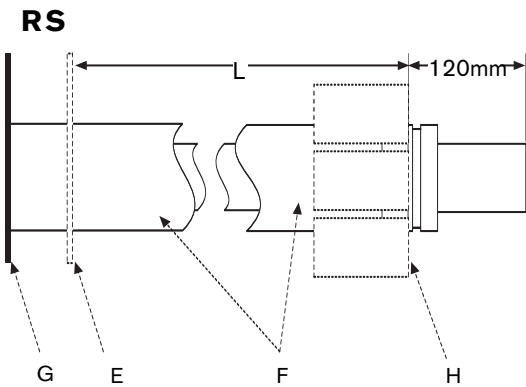

FLUE INSTALLATION

The flue can exit the boiler from outlets A, B, C or D allowing vertical (RS) and horizontal (RS low or high level) flues to be fitted. (CF position 'A' only).

Refer to the separate flue installation instructions supplied with the flue kits available for this boiler:

RS FLUE KITS & COMPONENTS

80/125mm Ø (not supplied):

- Horizontal flue kit: Part No. 7 716 190 031
- Vertical flue kit: Part No. 7 716 190 032
- Extension kit (1 metre) x1: Part No. 7 716 190 033
- Inline elbow 90° x1: Part No. 7 716 190 034
- Inline elbow 45° x2: Part No. 7 716 190 035
- Stainless steel horizontal terminal guard: Part No. 7 716 190 050

100/150mmØ (not supplied) for 25/32 vertical terminal:

- Vertical flue kit: Part No. 7 716 190 044
- Extension kit (1 metre) x1: Part No. 7 716 190 045
- Inline elbow 90° x1: Part No. 7 716 190 046
- Inline elbow 45° x2: Part No. 7 716 190 047
- Inline adaptor 80/125 to 100/150mm Ø: Part No. 7 716 190 063

CF FLUE KIT all models (not supplied):

- For Greenstar Camray 12/18 and 18/25 models use CF Adaptor kit: Part No. 7 716 190 036.
- For Greenstar Camray 25/32 models use CF Adaptor kit: Part No. 7 716 190 036 and CF Adaptor 100/130mm: Part No. 7 716 190 065.

INSTALLATION NOTES:

- ▶ Ensure all flue seals are in good condition and seated properly.
- ▶ To ease assembly of flue components, grease seals lightly with the solvent-free grease supplied.
- ▶ Use flue clamps to support the flue system.

IMPORTANT: The boiler is not designed to take the weight of the flue system, this must be supported externally to the boiler.

- ▶ All horizontal flue sections must rise by at least 52mm for each metre away from the boiler to ensure that condensate flows back into the boiler for safe discharge via the condensate waste pipe.

COMBUSTION CHAMBER

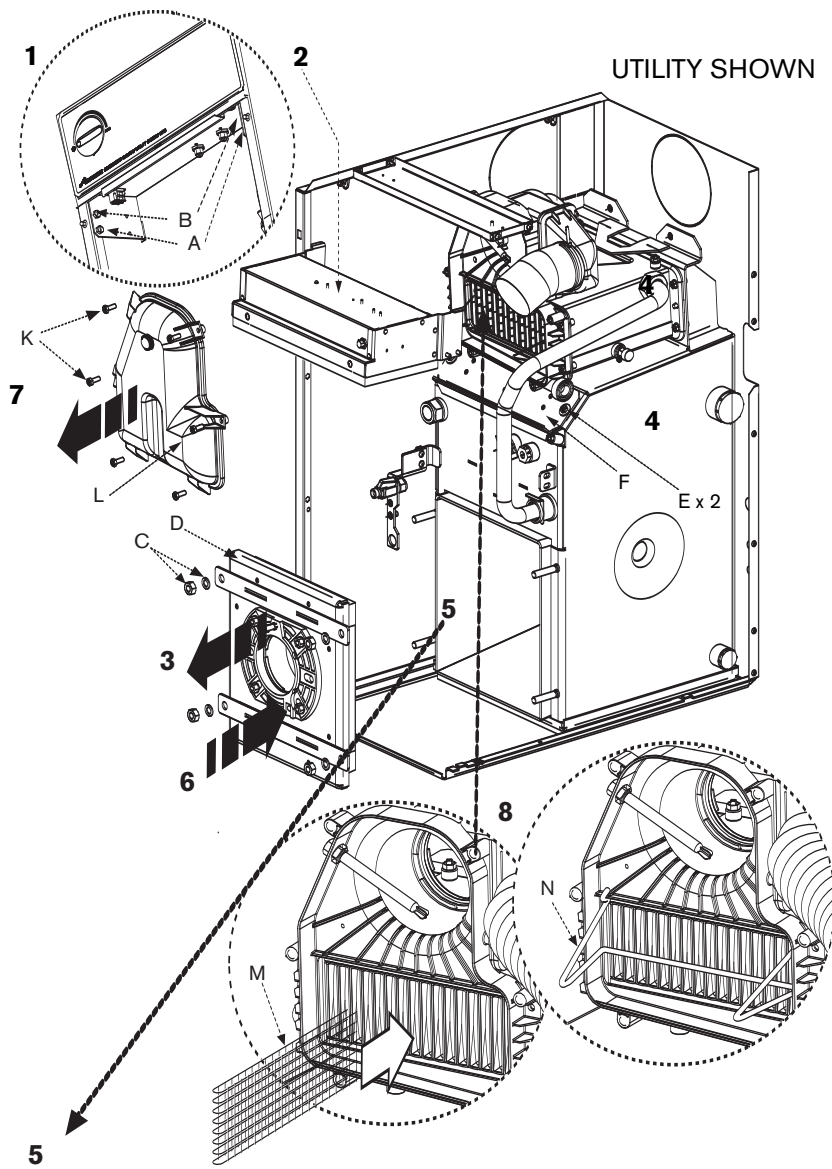

Combustion chamber:

- 1 ▶ Remove the control box securing screws (A, bottom screw both sides) and loosen the pivot screws (B, top screw both sides).
- 2 ▶ Pivot down control box.
- 3 ▶ Release retaining nuts and washers (C).
 - ▶ Remove combustion chamber access door (D).
- 4 ▶ Release screws (E) on either side and remove upper access door (F).
- 5 ▶ Ensure baffles (G) and baffle retainers (H), restrictor plates (I) and acoustic insulation insert (J) are correctly fitted for the boiler model as shown in the plan view opposite.
 - ▶ Refit the upper access door (F) and secure with screws (E).
- 6 ▶ Secure combustion chamber access door with nuts and washers (C). Tighten until door is firmly secured using the sequence below. Do not overtighten the nuts.
- 7 ▶ Unscrew screws (K) and remove flue manifold access cover (L).
- 8 ▶ Check that all the baffles (M) and baffle retainer (N) are correctly fitted to the secondary heat exchanger.

12/18

Plan sectional view

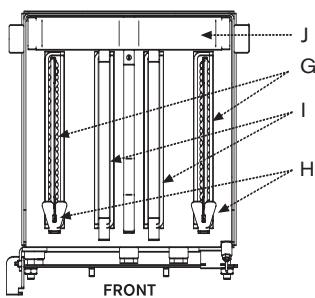

18/25

Plan sectional view

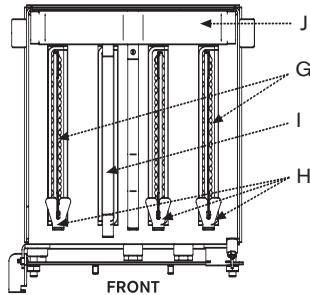

25/32

Plan sectional view

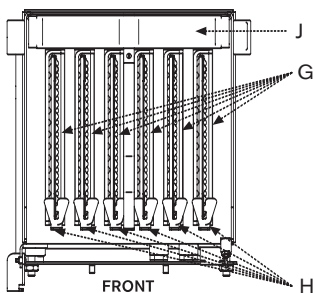

IMPORTANT when refitting the combustion chamber access door (6)

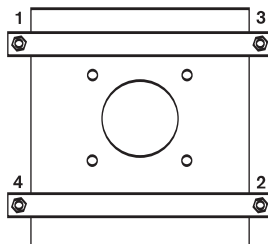

Combustion chamber access door tightening sequence.

PIPEWORK CONNECTIONS

CAUTION: ISOLATE THE OIL & WATER MAINS SUPPLY BEFORE STARTING ANY WORK AND OBSERVE ALL RELEVANT SAFETY PRECAUTIONS.

UTILITY SYSTEM SHOWN

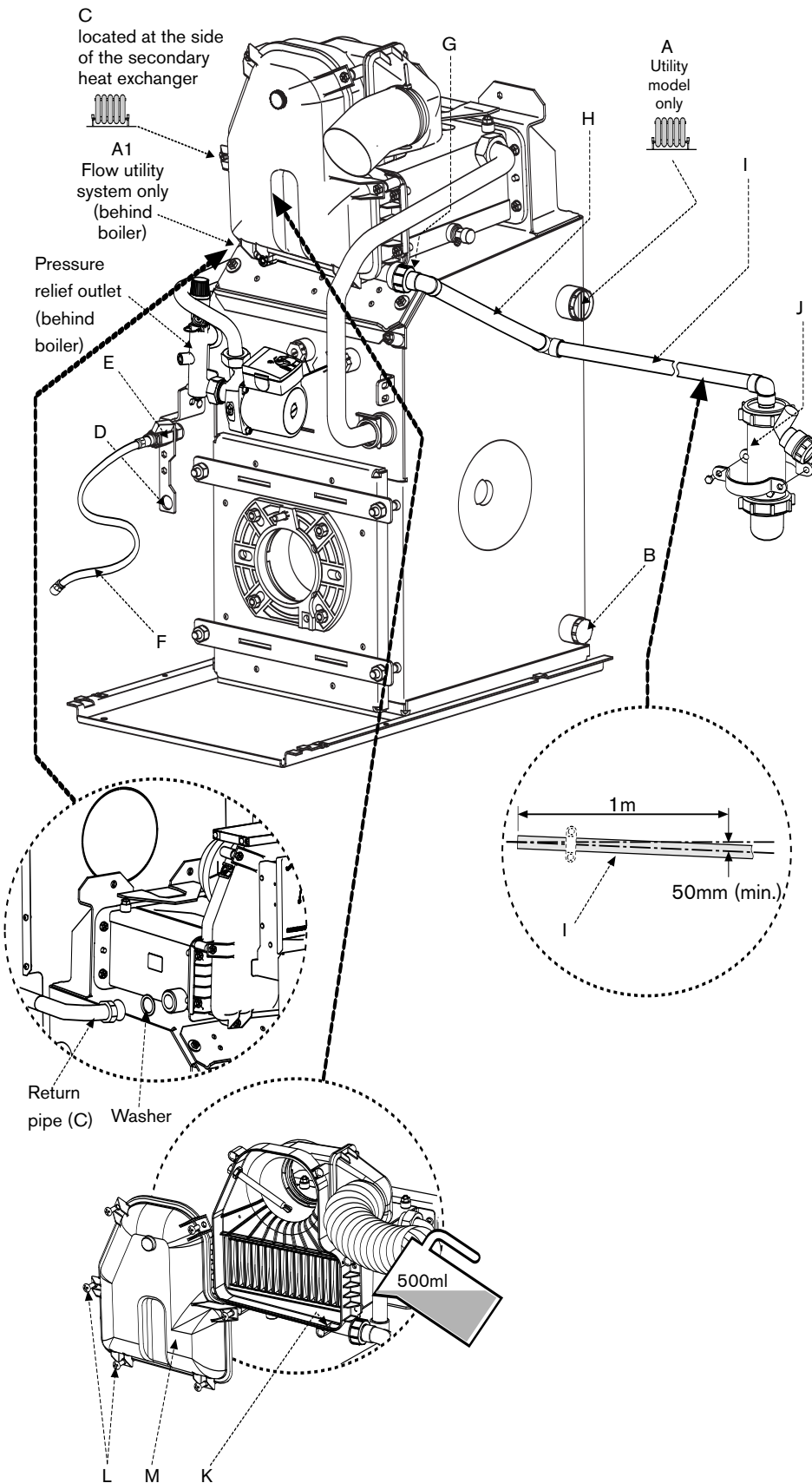

- A - Flow (Utility models only)/open vent 1" BSP (1 1/4" BSP for 25/32 models)
- A1 - Flow Utility System models only 22mmØ copper (28mmØ copper for 25/32 models)
- B - Primary drain/cold feed 3/4" BSP
- C - Return 22mm Ø copper (28mm Ø on 25/32 models)
- D - Fixing point for optional return oil pipe.
- E - Oil isolating valve (10mmØ)
- F - Flexible oil pipe
- G - Flue manifold condensate outlet
- H - Condensate outlet (21.5mmØ) - supplied
- I - Condensate pipe - not supplied
- J - Condensate trap with wall clamp - supplied

WATER CONNECTIONS:

- ▶ Remove the transit bungs from the pipework connections on the boiler.

NOTE: that surplus water may be present due to factory testing.

- ▶ Ensure all pipework is clean.
- ▶ Fit the return pipe to the secondary heat exchanger using the sealing washer supplied.
- ▶ Align water pipework and connect, ensuring that the expansion tank and control box fit correctly before permanently connecting the pipework.
- ▶ Check that all unused sockets have been capped.

OIL SUPPLY CONNECTIONS:

- ▶ Route the oil supply pipe along the left hand side of the boiler and connect to the isolating valve (E) and ensure the valve is closed.
- ▶ Connect the flexible oil pipe (F) to the isolating valve (E).

CONDENSATE CONNECTION:

- ▶ Fit the elbow (supplied) onto the condensate pipe (H) (supplied).
- ▶ Fit the sealing washer to the condensate pipe (H) and connect it to the flue manifold outlet (G).
- ▶ Fit the condensate trap in a serviceable position using the clamp supplied.
- ▶ Connect 21.5mm polypropylene pipe (I) (not supplied) to the condensate pipe (H) and condensate trap (J) before terminating to waste.
- ▶ Ensure that the condensate pipe runs away from the boiler at a constant fall of 50mm (min.) for every metre.
- ▶ **Carefully pour 500ml of water into the condensate collection (K) to fill condensate trap.**
- ▶ Check the water is running away and the condensate pipework joints are water tight.
- ▶ Check the flue manifold seal is undamaged and seated correctly.
- ▶ Refit flue manifold access cover (M) and secure with screws (L).

IMPORTANT: The condensate trap must be correctly filled to prevent the possibility of potentially harmful flue products escaping via the condensate pipework.

OIL BURNER & PUMP

CAUTION: ISOLATE THE OIL & WATER MAINS SUPPLY BEFORE STARTING ANY WORK AND OBSERVE ALL RELEVANT SAFETY PRECAUTIONS.

OIL BURNER:

- 1 ▶ Check the nozzle (A) and electrode (B) settings are correct as shown opposite.
- ▶ Ensure nozzle (A) is aligned centrally within the combustion head (C).
- ▶ Inspect for any visible defects.

2 IMPORTANT: Before removing or fitting a nozzle (A), loosen screw (D) and move the electrodes (B) forward.

After refitting check that the electrode gaps are correct, as shown opposite.

NOTE: the 12/18 model has a brass deflection washer and locating circlip behind the nozzle. These must be in place for the correct operation of the burner.

IMPORTANT: Whenever replacing the combustion head, ensure that the photocell is lined up with the sight hole.

OIL PUMP:

Connecting the oil pump for a single pipe system:

- ▶ The pump is factory set for single pipe operation with the flexible oil pipe fitted.
- ▶ Check connections before use.

Converting the oil pump for a double pipe system:

- 1 ▶ Check the inlet pipe connection (1).
- ▶ Unscrew return plug (2).
- ▶ Screw in by-pass screw (3).
- 2 ▶ Connect the flexible oil pipe **return** hose (not supplied) to the oil pump and return pipe fixing (D on page 24) and tighten to secure.

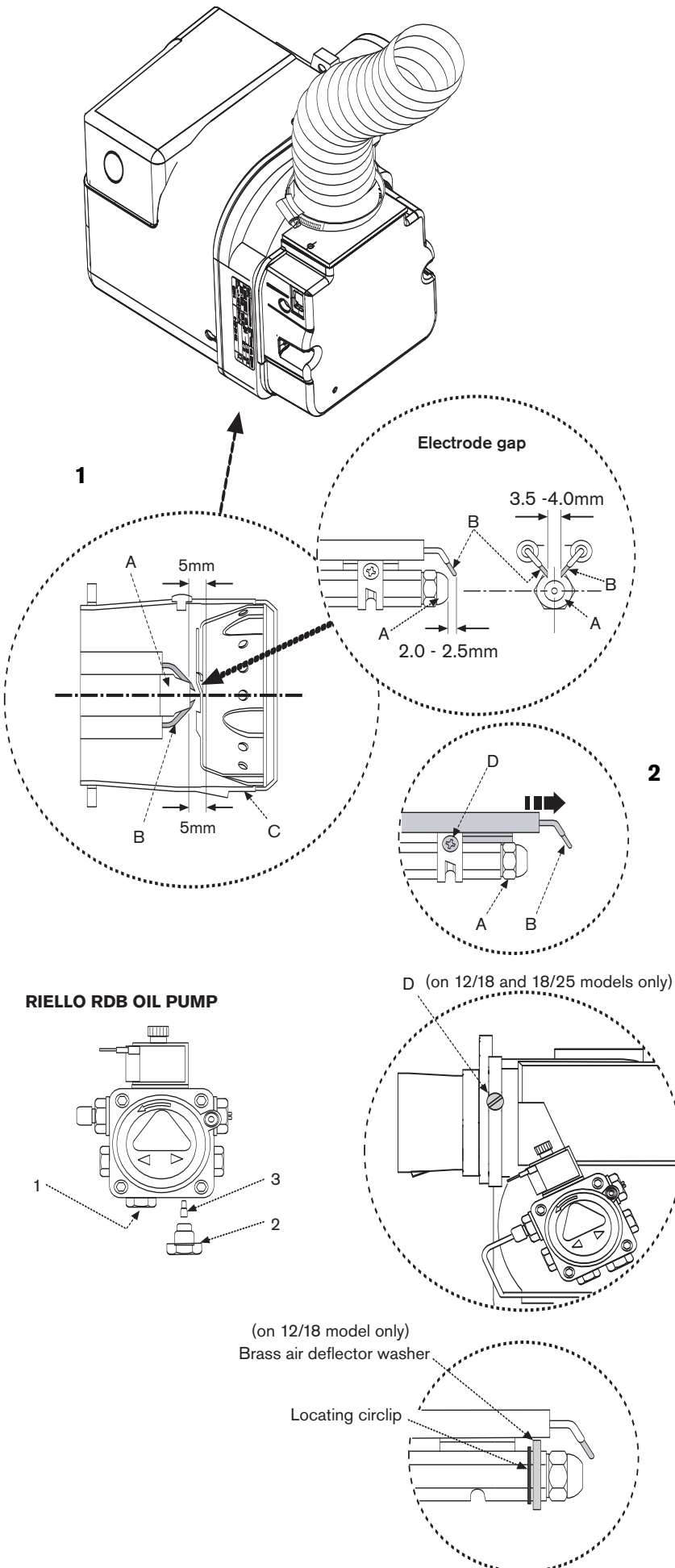

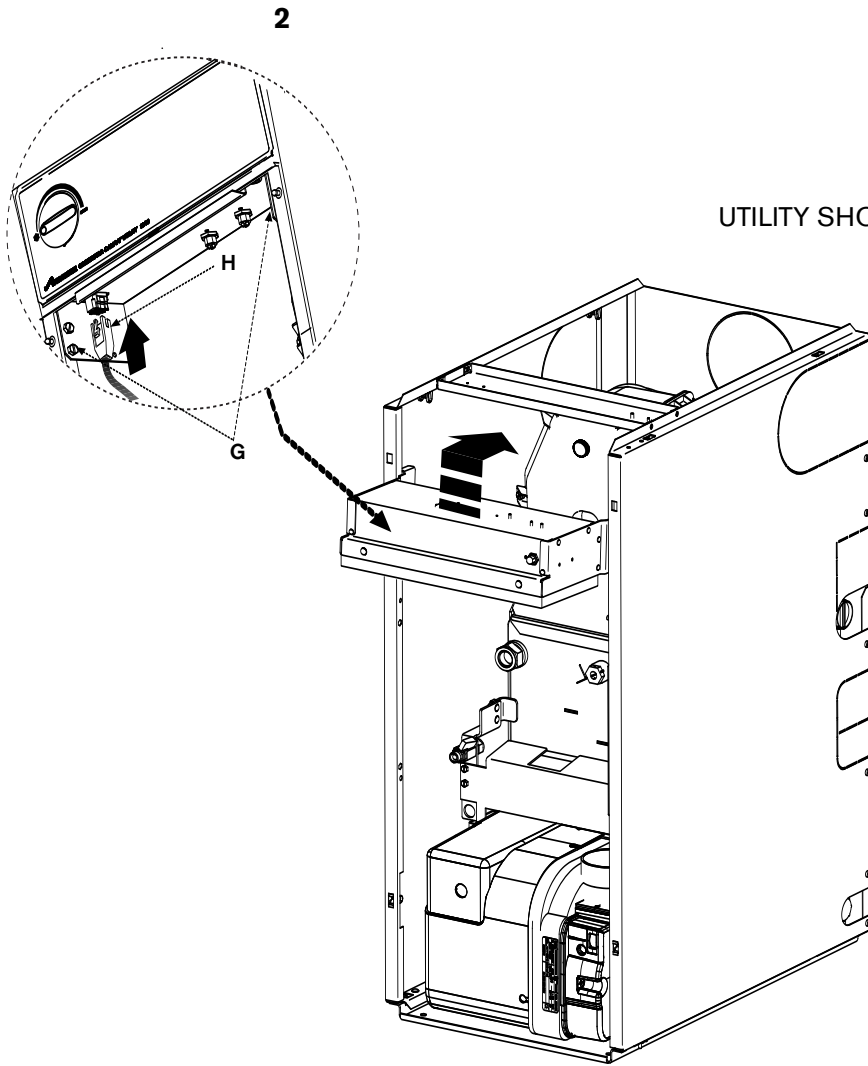

UTILITY SHOWN

- 1 ▶ Align burner combustion head into boiler collar.
 - ▶ Locate the burner retainer (A) over the threaded lug on the collar (B), push the burner firmly onto the flange and secure in place with the retaining nut (C). Tighten sufficiently but do not overtighten.
 - ▶ Check that the burner is seated correctly on its mounting flange and that the oil pipe/s are not trapped in front of or underneath the burner.
 - ▶ Refit the deflector plate (D) and secure with screws (E). Ensure that the flexible oil pipe/s are not positioned between the deflector plate and the combustion chamber door.
 - ▶ Attach air duct pipe and tighten clip (F) to secure to the burner air intake.
- 2 ▶ Swing control box back up into operating position and retain in place by replacing the two securing screws (G) in the bottom locations.
 - ▶ Plug burner lead (H) into control box.

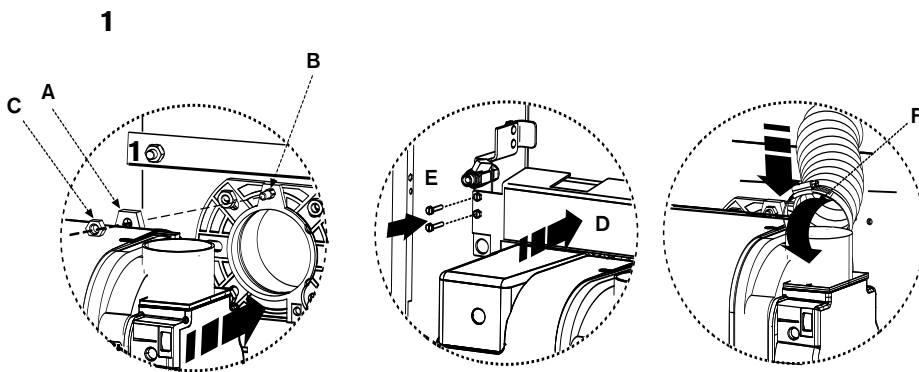

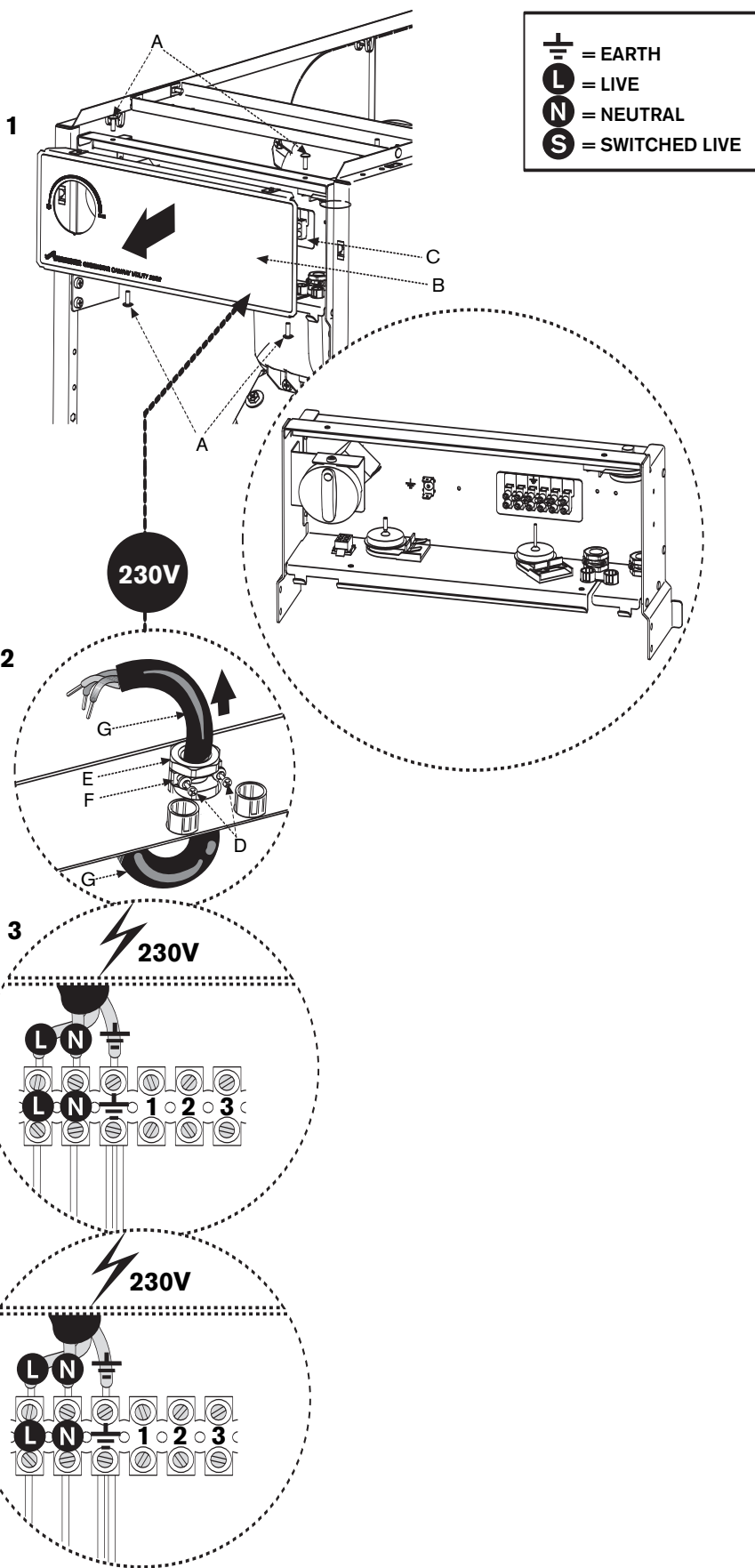

DANGER - 230V:
ISOLATE THE MAINS ELECTRICITY SUPPLY BEFORE STARTING ANY WORK AND OBSERVE ALL RELEVANT SAFETY PRECAUTIONS.

Access to 230V connections:

- 1 ▶ Release screws (A) and remove front panel (B) from control box (C).
- 2 ▶ Release screws (D) from cable clamp (E).
 - ▶ Pull inner clamp part (F) outwards.
 - ▶ Feed sufficient power cable (G) through the cable clamp (E) and secure grip with screws (D).
 - ▶ Separate wires from cable end and strip to 6mm.

230V connections:

- 3 ▶ Connect LIVE wire (Brown) to terminal L.
- ▶ Connect NEUTRAL wire (Blue) to terminal N.
- ▶ Connect EARTH wire (Green/Yellow) to the terminal \perp .

Route the power cable down the side panel using the clip provided on the support panel to the external connection point avoiding any potentially hot surfaces allowing sufficient cable to open the control box.

Any external device connected to the system must take its power supply from the boiler supply only and must NOT have a separate supply.

See the following pages of electrical diagrams for details of different systems.

Refit electric control panel cover:

- ▶ Refit front panel (B) to control box (C) and secure with screws (A).

UTILITY MODEL:
230V STANDARD WIRING DIAGRAM:

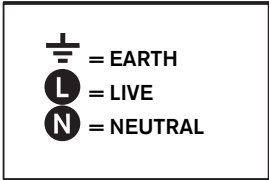

- Key to components:
- A - EARTH STUD.
 - B - HIGH LIMIT THERMOSTAT.
 - C - BOILER MANUAL RESET OVERHEAT THERMOSTAT.
 - D - FLUE MANUAL RESET OVERHEAT THERMOSTAT.
 - E - TERMINAL CONNECTOR BLOCK.
 - F - CONTROL THERMOSTAT.
 - G - BURNER SOCKET.
 - H - BURNER PLUG.
 - J - BURNER CONTROL BOX.

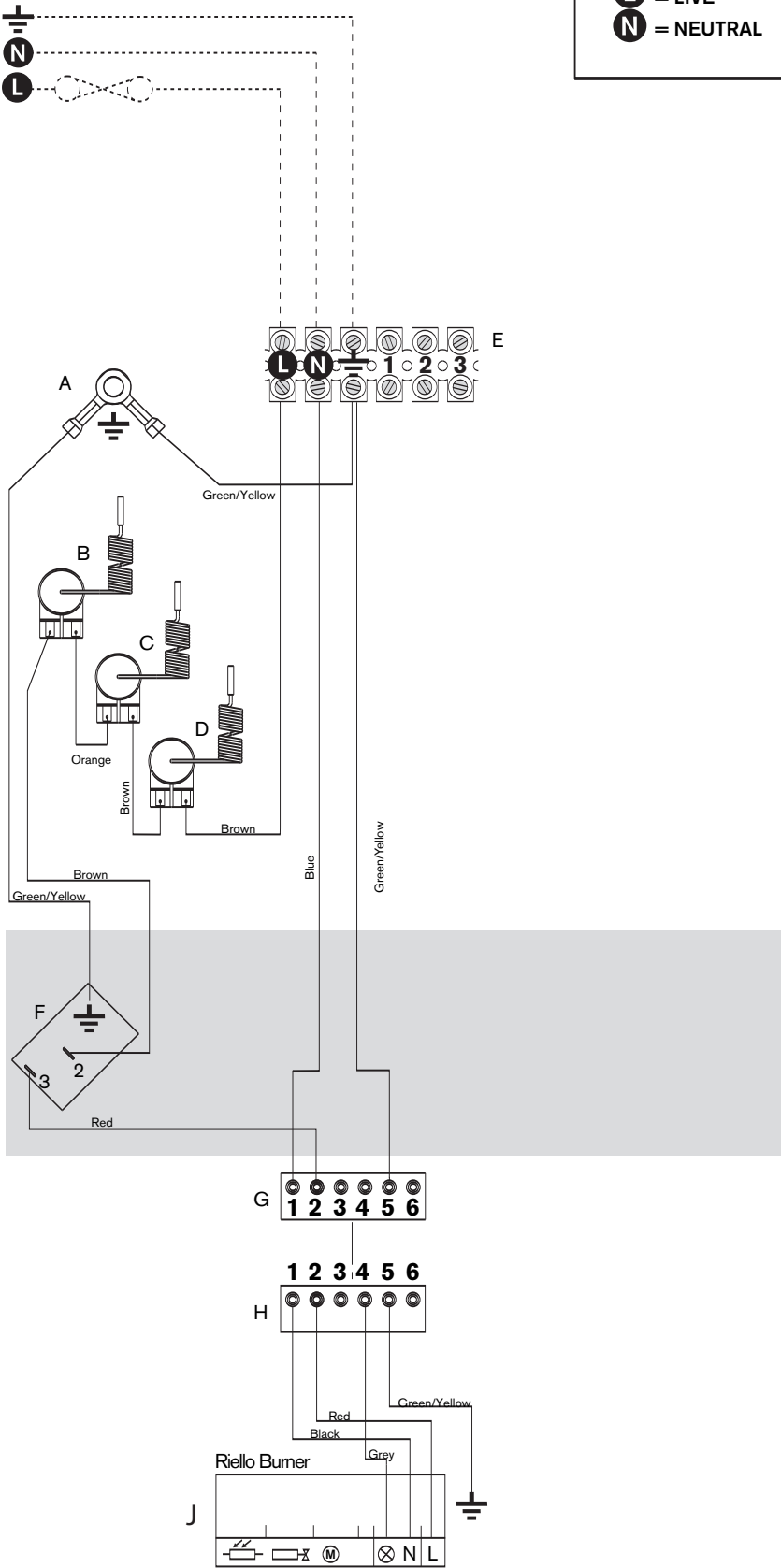

INSTALLATION

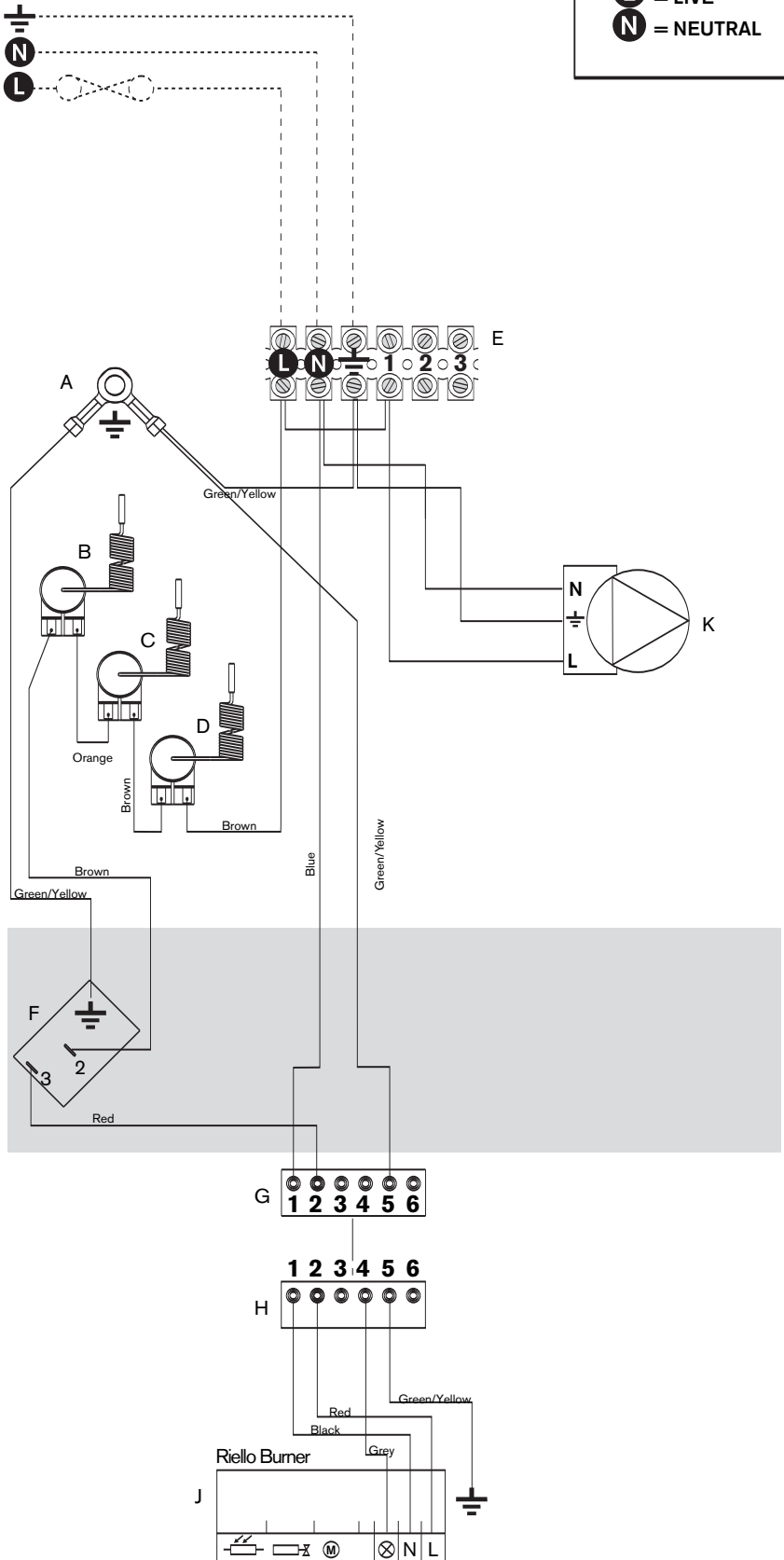

UTILITY SYSTEM MODEL:
230V STANDARD WIRING DIAGRAM:

Key to components:

- A - EARTH STUD.
- B - HIGH LIMIT THERMOSTAT.
- C - BOILER MANUAL RESET OVERHEAT THERMOSTAT.
- D - FLUE MANUAL RESET OVERHEAT THERMOSTAT.
- E - TERMINAL CONNECTOR BLOCK.
- F - CONTROL THERMOSTAT.
- G - BURNER SOCKET.
- H - BURNER PLUG.
- J - BURNER CONTROL BOX.
- K - CIRCULATING PUMP.

E = EARTH
L = LIVE
N = NEUTRAL
S = SWITCHED LIVE

**UTILITY MODEL:
REMOTE 2 OR 3 PORT VALVE CONTROL SET
USING REMOTE PROGRAMMER:**

Key to components:

K - REMOTE JUNCTION BOX (10-way) to connect the following (refer to manufacturers instructions):

- ▶ Mains wiring 230V 50Hz.
- ▶ Hot water tank thermostat.
- ▶ Room thermostat.
- ▶ System water valves.
- ▶ Circulating pump.
- ▶ External programmer.

E - TERMINAL CONNECTOR BLOCK.

Remote (10 way) junction box (K) requirements:

- ▶ The junction box (K) must be a terminal block type, current rated to at least 5 amps.
- ▶ A 5 amp fuse must be fitted to the mains supply.
- ▶ The junction box (K) must be fitted externally to the boiler.

A frost thermostat can also be connected to the remote junction box if required.

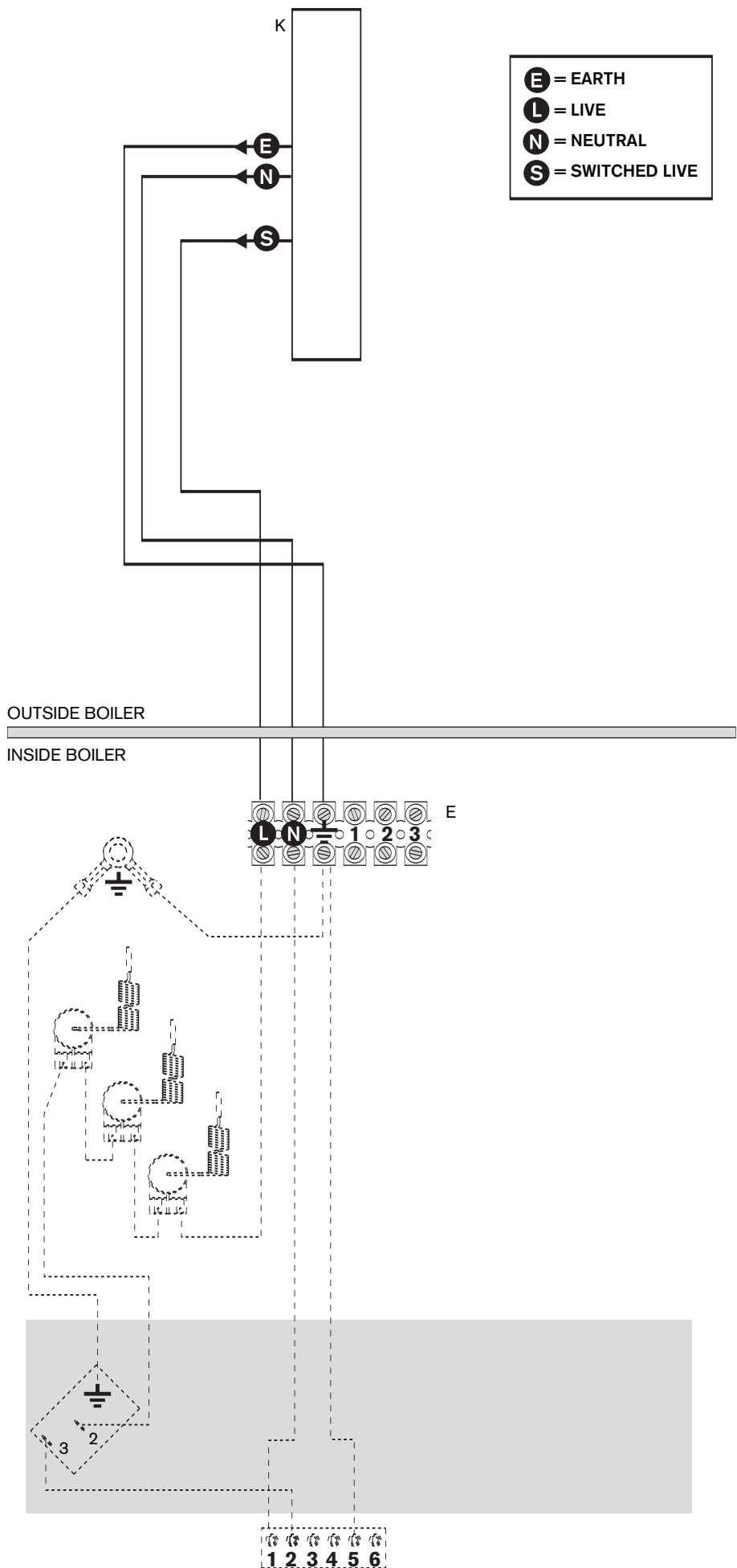

INSTALLATION

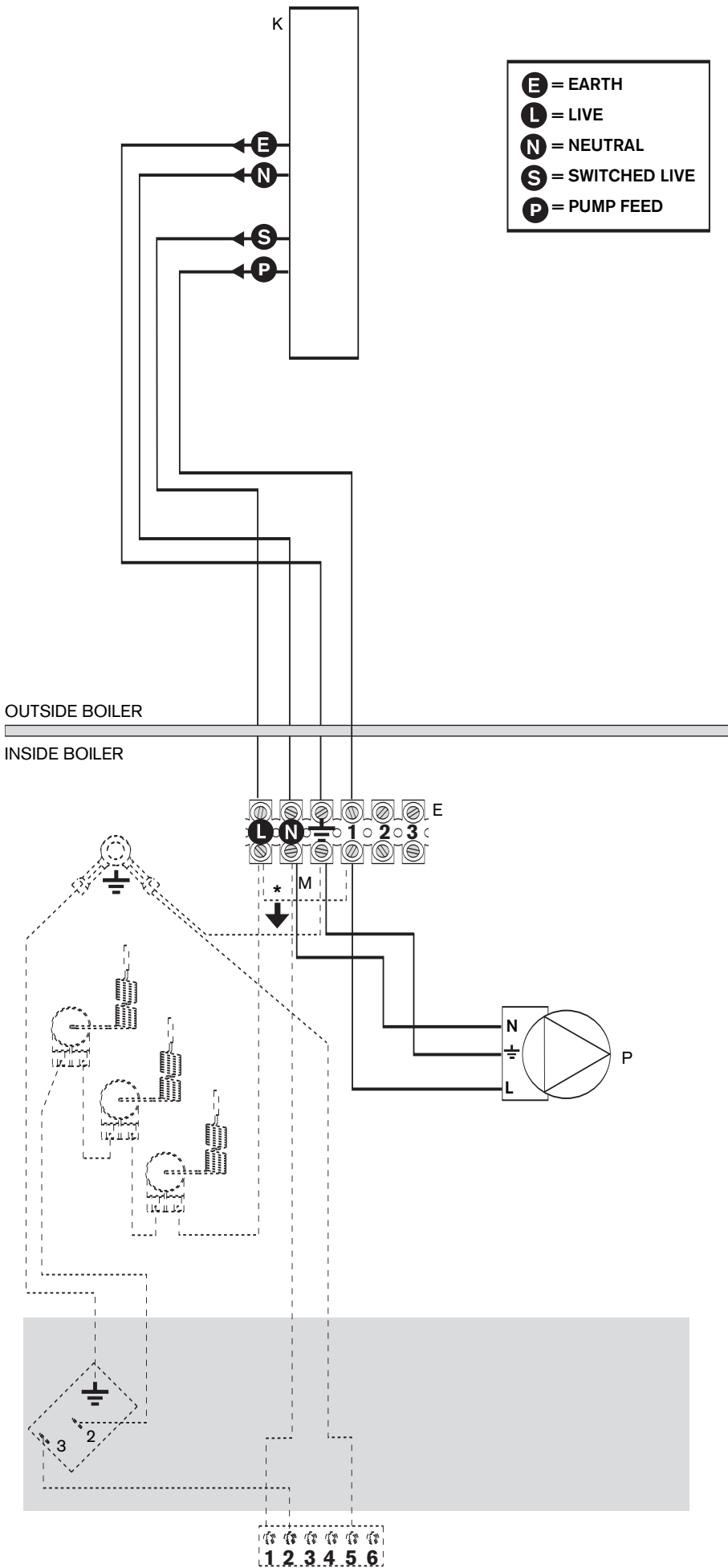

- E** = EARTH
- L** = LIVE
- N** = NEUTRAL
- S** = SWITCHED LIVE
- P** = PUMP FEED

**UTILITY SYSTEM MODEL:
PRE-WIRED REMOTE 2 OR 3 PORT VALVE
CONTROL SET USING REMOTE
PROGRAMMER:**

Key to components:

K - REMOTE JUNCTION BOX (10-way) to connect the following (refer to manufacturers instructions):

- ▶ Mains wiring 230V 50Hz.
- ▶ Hot water tank thermostat.
- ▶ Room thermostat.
- ▶ System water valves.
- ▶ Circulating pump.
- ▶ External programmer.

E - TERMINAL CONNECTOR BLOCK.

M - PUMP LINK

Remote (10 way) junction box (K) requirements:

- ▶ The junction box (K) must be a terminal block type, current rated to at least 5 amps.
- ▶ A 5 amp fuse must be fitted to the mains supply.
- ▶ The junction box (K) must be fitted externally to the boiler.

A frost thermostat can also be connected to the remote junction box if required.

*If the junction box has a pump overrun feature remove link (M) and connect a wire between the junction box pump feed and terminal 1 on the connector block.

If the junction box does not have a pump overrun feature no separate pump feed will need to be run to the boiler, leave link (M) in place.

UTILITY SHOWN

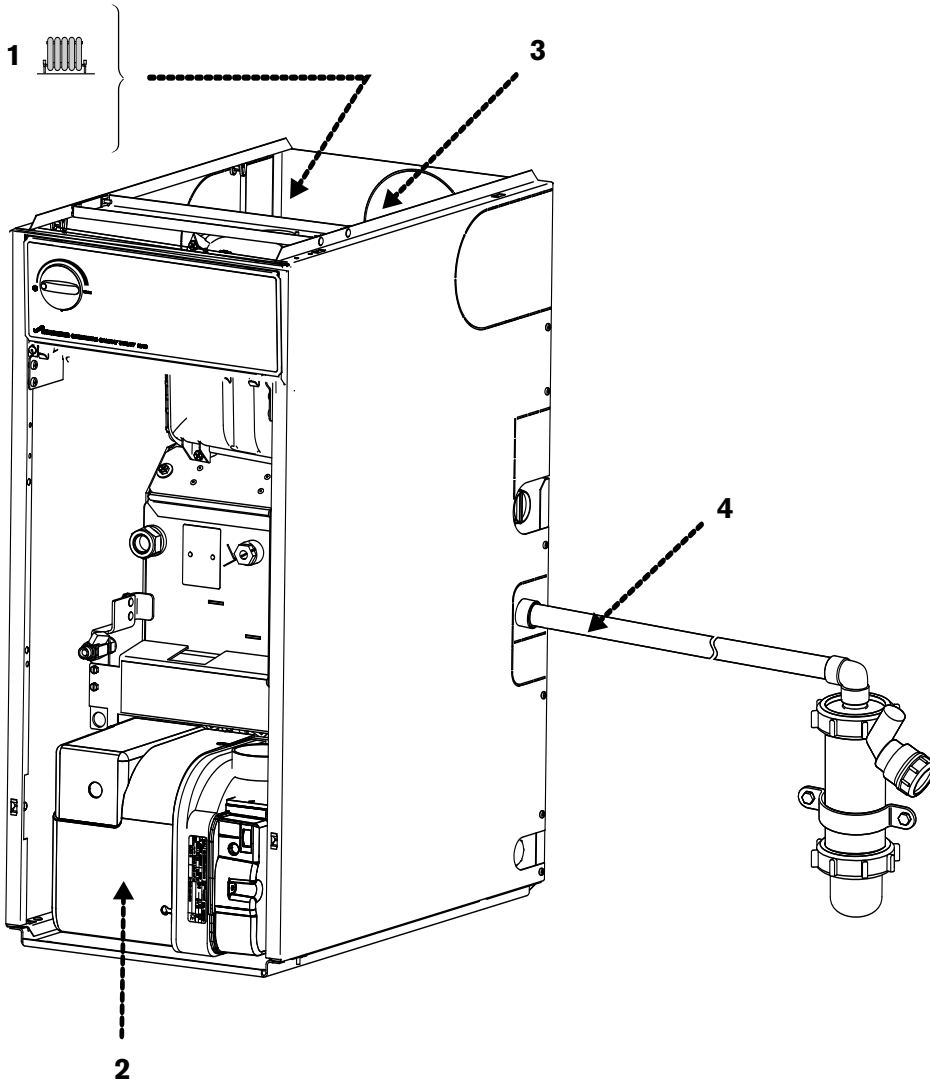

CAUTION: ISOLATE THE MAINS SUPPLIES BEFORE STARTING ANY WORK AND OBSERVE ALL RELEVANT SAFETY PRECAUTIONS.

- 1 ▶ Check that the service and water pipes are connected correctly.
 - ▶ Check that all unused sockets are capped.
- 2 ▶ Check that the oil supply is 28 sec kerosene and that the pipework is connected correctly to the oil pump, via the supplied flexible oil pipe.
 - ▶ Check that the burner is seated correctly on its mounting flange and that the oil pipe/s are not trapped in front of or underneath the burner.
 - ▶ Turn on the main oil supply valve at the tank, check the oil supply pipework and connections. Rectify any leaks.
- 3 ▶ Check the flue is correctly fitted and the connections are secure.
- 4 ▶ Check the condensate pipework is correctly fitted and connected.
 - ▶ Check the condensate trap is filled with water.

IMPORTANT: If the boiler is not to be commissioned immediately then:
After successfully completing all of the checks and any rectification work, close the water valves, shut off the oil supply and electrically isolate the boiler.
Complete the installation part of the Guarantee Registration Card, and complete a CD10 or equivalent, to inform the LABC of the installation.

UTILITY SYSTEM ONLY:
Refit the expansion vessel support bracket and the expansion vessel. Secure in place by retightening the expansion vessel clamping screw.

Refit the top and front panels.

FILLING THE SYSTEM

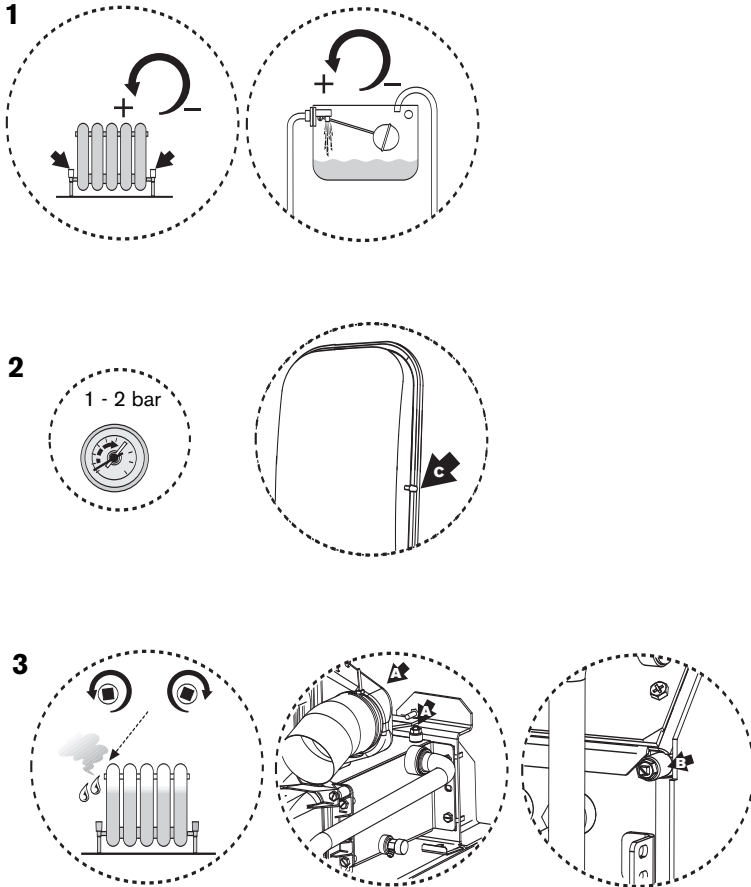

- 1 ▶ Open all system and radiator valves.
 - ▶ Turn on the water main stop cock.
 - ▶ Open vented systems only:
 - ▶ Turn on the water to the system feed and expansion cistern and allow the system to fill.
- 2 ▶ Sealed systems only:
 - ▶ Check and if required, adjust the expansion vessel pressure using the Schraeder type valve (C).
 - ▶ Fill the system to between 1 and 2 bar pressure via a WRAS approved filling link.
 - ▶ Monitor the pressure gauge during venting and repressurise if required.
- 3 ▶ Vent all radiators, retighten when completed.
 - ▶ Check the system and correct any leaks.
 - ▶ Bleed air from at least one of the secondary heat exchanger air vents (a radiator key is ideal for this). There are two venting bosses (A) on the top of the secondary heat exchanger. Only one is used if fluing to the side. The (A) in use and (B) must be bled.
 - ▶ Bleed air from the primary heat exchanger air vent (B).

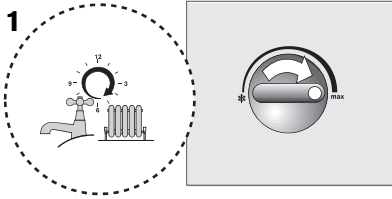

**RIELLO
RDB OIL PUMP**

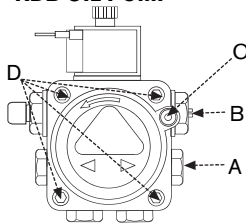

- A - Bleed & pressure gauge port
- B - Pressure adjustment
- C - Vacuum gauge port
- D - Retaining screws - cover

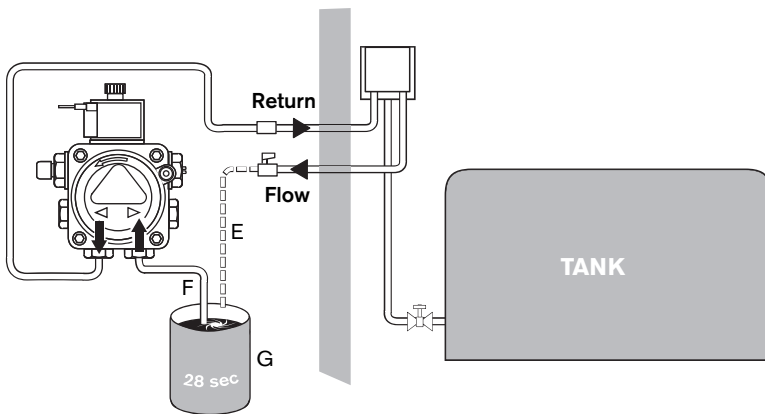

BURNER LOCKOUT

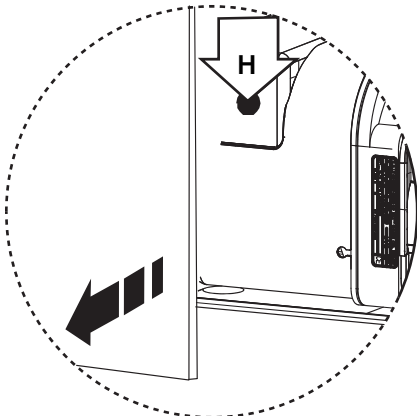

INTEGRAL BURNER LOCKOUT INDICATOR AND RESET BUTTON (H)

IMPORTANT: Never run the appliance when the appliance/system is unpressurised (sealed systems) or empty.

- 1 ▶ Check the oil supply is correctly fitted and in good working order before turning on the oil supply valves to the boiler.
- ▶ Turn on the main oil supply valve at the tank and draw off oil until a steady flow of clear uncontaminated oil can be seen as follows:
 - **The oil supply to the boiler should be primed before the burner is operated to avoid unnecessary pump wear.**
 - **The use of an oil suction pump will prime and flush through any oil supply set up simply and easily. Alternatively the following procedures can be used:**
 - ▶ **Single pipe gravity feed systems:**
 - ▶ Disconnect the flexible oil pipe and open the isolating valve to discharge the oil into a suitable container.
 - ▶ If a top entry tank has been used the pipework will need to be primed before the oil will discharge under gravity.
 - ▶ When completed, close the isolating valve, reconnect the flexible oil pipe.
 - ▶ **Double pipe sub-gravity feed systems and single pipe suction lift with de-aerator:**
 - ▶ Prime the oil supply pipework to prevent oil pump damage .
 - ▶ To prime a de-aerator, disconnect the flexible oil inlet hose (F) from the isolation valve and place in a container of kerosene (G). Connect a spare flexible oil hose (E), to discharge into container (G). Open the isolating valve, turn on the power to the boiler and set the programmer to ON. Prime the de-aerator until there is a steady flow of oil into container (G). Turn off the boiler then reconnect the flexible oil inlet hose (F).
 - ▶ Turn on the boiler, the oil level in the de-aerator will drop as the oil is used until the oil is drawn from the tank. If the de-aerator empties and the burner locks out before the oil is drawn from the tank prime the de-aerator again.
 - ▶ Open the isolating valve and the oil pump bleed valve (A) to discharge into a suitable container once the boiler is started up.
 - ▶ Switch on the electricity supply to the boiler.
 - ▶ Set the programmer to ON.
 - ▶ Turn on the boiler control thermostat.
 - ▶ Allow the burner to run through to 'lock-out' indicated by the illumination of the lockout indicator (H), (note: some systems will not lock out).
 - ▶ If lockout occurs wait 2 minutes then press the lockout reset button (H).
 - ▶ Repeat the procedure at least 3 times or until a steady stream of oil, without air, runs from the bleed port then relock the bleed port.
 - ▶ Switch off the boiler.
 - ▶ Remove the oil pump filter, clean with kerosene and refit.

The internal filter is accessed by removing the oil pump cover.

 - ▶ Safely dispose of the container/discharge.

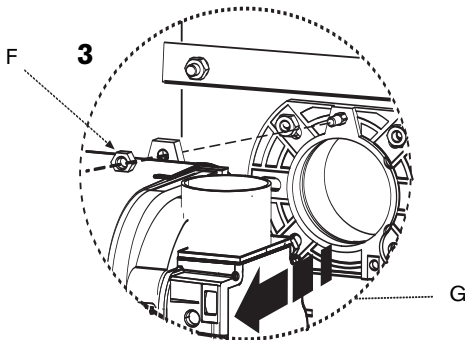
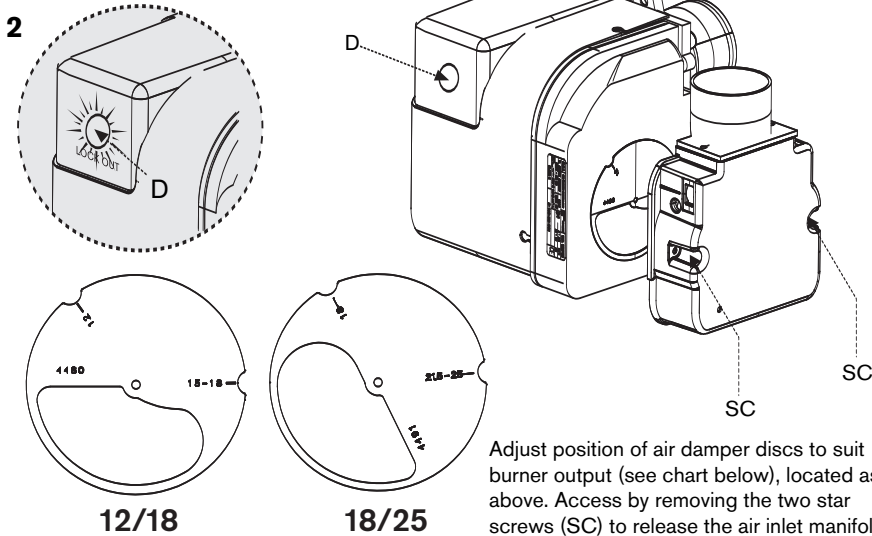

**RIELLO
RDB OIL PUMP**

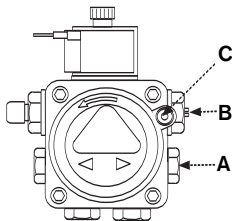

- A - Bleed & pressure gauge port
- B - Pressure adjustment
- C - Vacuum gauge port

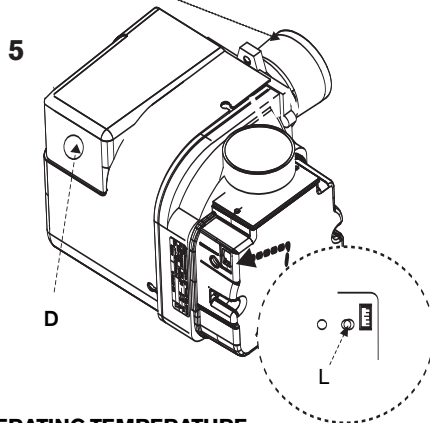
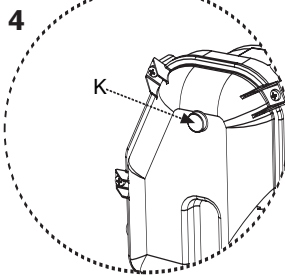

STARTING THE APPLIANCE

- 2 ▶ Remove plastic cover from the burner casing.
 - ▶ Fit a suitable pressure gauge to port (A) on the oil pump.
 - ▶ Adjust the air shutter (L) and pump pressure (B) as shown in the table opposite. The burner should ignite following a pre-ignition period of approx. 15 seconds.
 - ▶ If changing the burner output, check the position of the air damper disc is correct to the output as shown in the table below.
- NOTE: For 25/32 appliance see following page.**

Boiler lockout indicator on:

If the burner fails to establish a normal firing pattern or flame failure occurs the flame monitoring photocell mounted in the burner body will alert the burner control box to shut the burner down and provide a safe lockout state indicated by the illumination of the lockout indicator (D).

- ▶ Wait 2 minutes then press the lockout reset button (D) to initiate another start sequence.
- ▶ Repeat procedure until a flame is established.

- 3 ▶ Start and run for 3 minutes then switch off.
- ▶ Check for after-spurting from the nozzle, indicated by oil saturation on the combustion head (G).

If after-spurting occurs:

- ▶ Release the burner retainer (F).
- ▶ Remove the burner, combustion head (G) and electrodes, hold the burner vertical to unscrew the nozzle and fill the nozzle holder with kerosene.
- ▶ Refit nozzle, electrodes, combustion head (G) and the burner.
- ▶ Restart and run for 3 minute intervals until after-spurting stops.

- 4 ▶ Start and run for 20 minutes.
- ▶ Remove sampling point plug (K) to check the smoke reading is between 0-1. If the smoke level is above 1, check the combustion settings are correct and the oil nozzle is in good condition.

Note; smoke readings may be inaccurate until the smoke from burning organic binder in the access door insulation has ceased.

- ▶ Check the CO₂ levels and adjust the air shutter (L) setting according to the table opposite.
- ▶ Check the flue gas temperature is close to the values shown in the table.

If the flue gas temperature is too high and the baffles are correctly fitted, then reduce the oil pump pressure (B) 5-10p.s.i. to compensate for nozzle variations.

- ▶ Turn off the electrical supply.
- ▶ Isolate the oil supply to the burner.
- ▶ Remove the oil pressure gauge.
- ▶ Refit the blanking plug (A).
- ▶ Check and rectify any oil leaks.

- 5 ▶ Switch on the oil supply.
- ▶ Switch on the electrical supply.
- ▶ Restart the boiler and run for 5 minutes.
- ▶ Recheck the CO₂ levels and if required, adjust the air shutter setting (L) to obtain the correct CO₂ level.

**NOMINAL BOILER RATING AT NORMAL OPERATING TEMPERATURE
USING 28sec KEROSENE:**

NOZZLE	OIL PUMP PRESSURE (p.s.i.)	FUEL FLOW RATE		APPROX. FLUE GAS TEMP °C	%CO ₂	APPROX. AIR SETTING	INPUT (APPLIANCE) kW	OUTPUT (APPLIANCE) kW	AIR DAMPER DISC SETTING	BURNER HEAD
		Kg/h	l/h							
Boiler 12/18 RDB 1										
0.40 60°ES	100	1.04	1.32	63	11.5	2.25	12.3	12.0	12	LD 2X SH 12/18
0.45 60°ES	120	1.28	1.63	67	11.5	2.5	15.4	15.0	15-18	LD 2X SH 12/18
0.55 x 80°EH	105	1.54	1.96	73	12.0	3.5	18.5	18.0	15-18	LD 2X SH 12/18
Boiler 18/25 RDB 2.2										
0.55 x 80°EH	105	1.55	1.96	75	11.0	3.5	18.5	18.0	18	T2 SH 18/25
0.60 60°ES	138	1.84	2.33	81	12.0	2.5	22.1	21.5	21.5-25	T2 SH 18/25
0.75 80°ES	120	2.15	2.72	81	12.5	4.5	25.7	25.0	21.5-25	T2 SH 18/25
Boiler 25/32 RDB 2.2										
*0.65 80°EH	140	2.15	2.72	80	11.0	4.5	25.7	25.0	N/A	T2 L/H 25/32
0.75 80°EH	125	2.37	3.0	81	12.0	4.0	28.3	27.5	N/A	T2 L/H 25/32
0.85 80°EH	125	2.58	3.27	83	12.5	4.5	30.8	30.0	N/A	T2 L/H 25/32

* 25/32 model for 25kW remove the plastic air guide (see following page).

STARTING THE APPLIANCE

On 25/32 Appliances:

To achieve the minimum output of 25kW from the 25/32 RDB 2.2 it is necessary to remove the air guide (D) from the burner. For any other required output the air guide must remain in place.

- ▶ Disassemble the burner, removing the red plastic cover, flexible air hose and air intake manifold (A).
- ▶ Remove the fan housing (B) by undoing the four securing screws.
- ▶ Remove the two screws (C) securing the plastic air guide.
- ▶ Remove air guide (D) and reassemble the burner in reverse order.

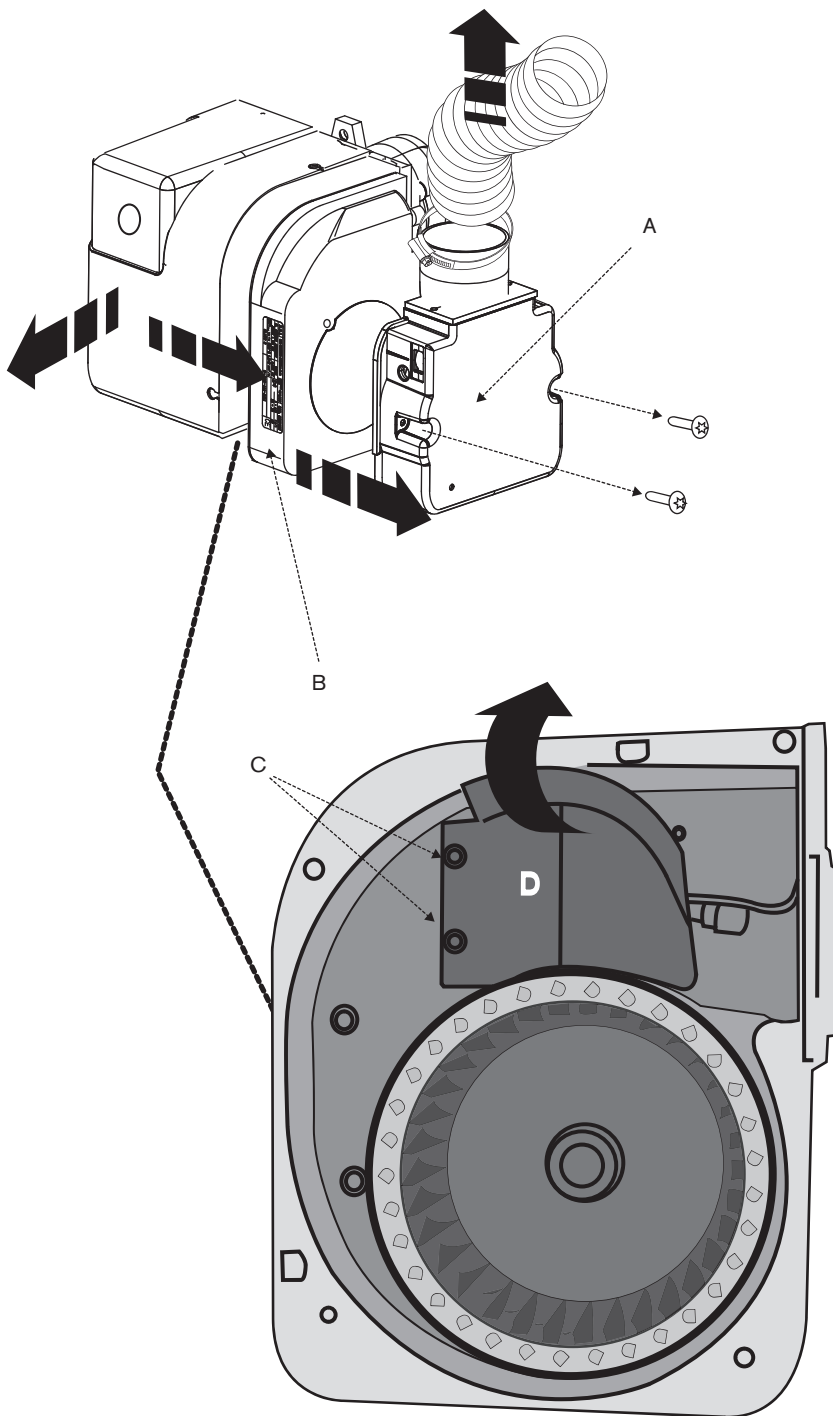

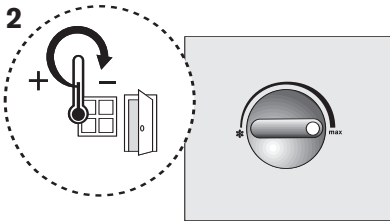
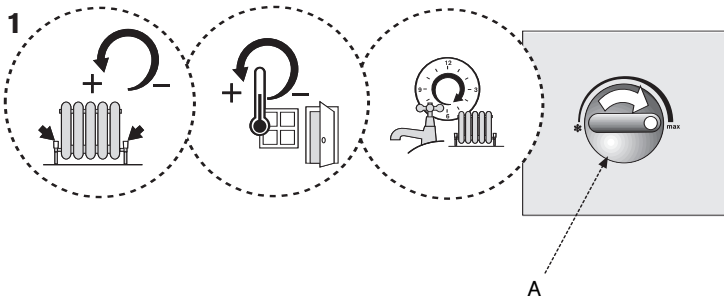

STARTING THE APPLIANCE

Central heating:

- 1 ▶ Open all radiator valves.
 - ▶ Set room thermostat to maximum.
 - ▶ Set programmer to ON.
 - ▶ Turn the thermostat control (A) to 'max'.

The burner should be ON with the circulating pump.

- ▶ Ensure all radiators are heating up evenly and balance the system to the temperature difference required for the heating flow and return according to the heating load.

2 ▶ Set the room thermostat to minimum.
Burner and circulating pump should be off.

- ▶ Check that any other controls that are fitted to the system are operating properly.

IMPORTANT: Debris from the system can damage the boiler and reduce efficiency. Failure to comply with the guidelines for the use of water treatment with the appliance will invalidate the appliance warranty.

FLUSHING (Central Heating):

- 1 ▶ Switch off the boiler.
 - ▶ Open vented systems only: turn off the water to the system header tank.
 - ▶ Open all radiator valves/drain cocks (B) and drain the system while the appliance is hot.
 - ▶ Close drain cocks (B).
- 2 ▶ Add a suitable flushing agent (F) and refill the system at the correct strength for the system condition in accordance with the manufacturer's instructions.
 - ▶ Vent the boiler using a radiator key or suitable screwdriver (there are two vent points (A) at the top of the secondary heat exchanger. Only one may be in use, the other may be obscured by side fluing. Always vent (A) and the vent point on the primary heat exchanger (C) and all radiators.
 - ▶ Run the boiler/system at normal operating temperature for the time stated by the flushing agent manufacturer.
- 3 ▶ Drain and thoroughly flush the system to remove the flushing agent and debris (B).

INHIBITOR (Central Heating):

- 4 ▶ Check drain cocks and manual air vents are closed and all radiator valves are open.
- 5 ▶ Add a suitable inhibitor (I), (or combined inhibitor/anti-freeze if the system is exposed to freezing conditions) to the heating system in accordance with the manufacturers instructions.

The inhibitor or combined inhibitor/anti-freeze must not cause damage to the materials within the boiler (mild steel, stainless steel, copper and brass) and any other materials/components within the system.

- ▶ Open vented systems only: turn on the water to the system header tank and allow the system to fill.
- ▶ Sealed systems only: fill the system to between 1 and 2 bar via a WRAS approved filling loop.
- 6 ▶ Vent the boiler, (there are two vent points (A) at the top of the secondary heat exchanger. Only one may be in use, the other may be obscured by side fluing. Always vent (A) and the vent point on the primary heat exchanger (C) and all radiators; retighten vents when complete.
- 7 ▶ Record the date when the inhibitor was added to the system on the guarantee card.

NOTE: The concentration level of inhibitor in the system should be checked every 12 months or sooner if system content is lost.

The addition of sealing agents to the system water is not permitted as this can cause problems with deposits left in the heat exchanger and invalidate the appliance and heat exchanger warranty .

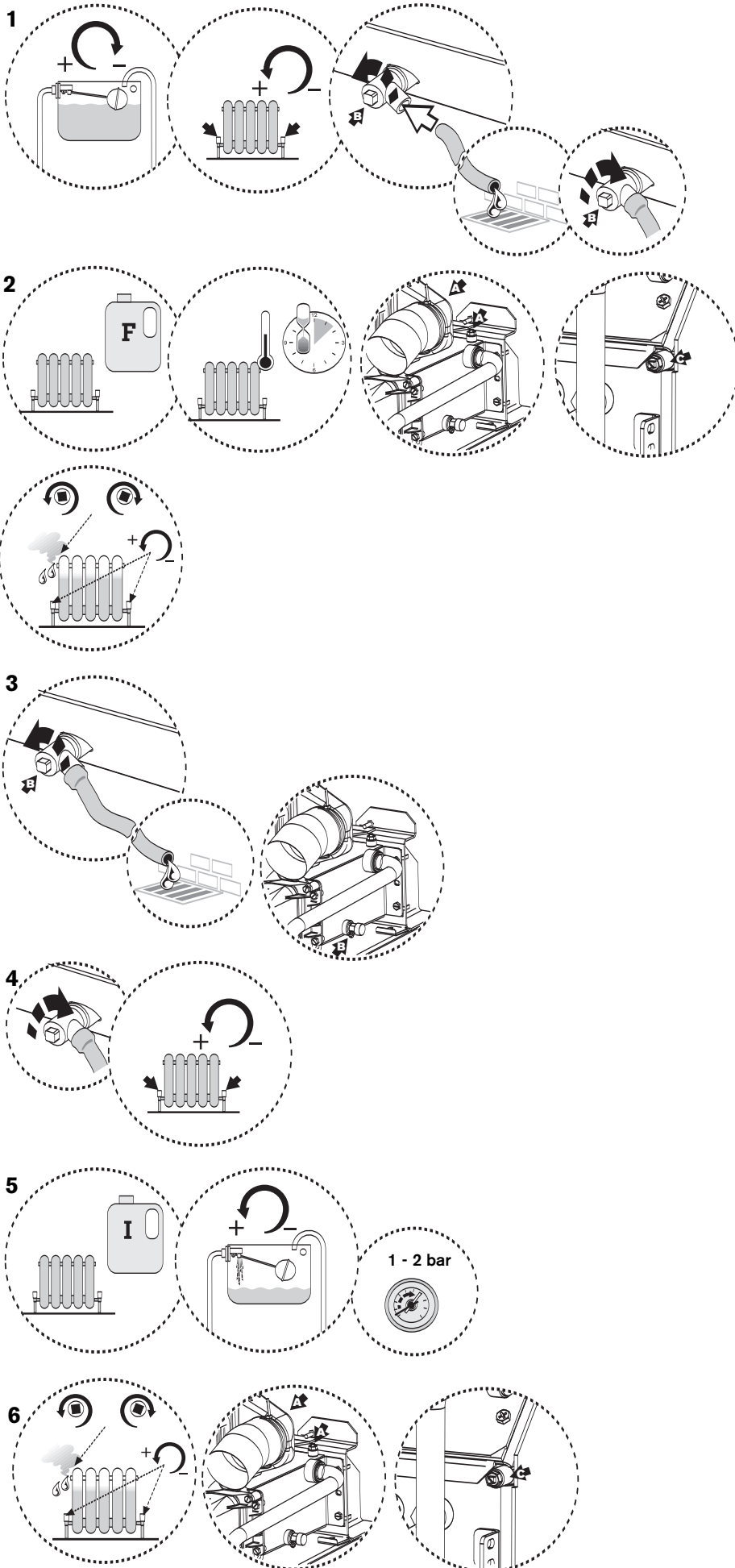

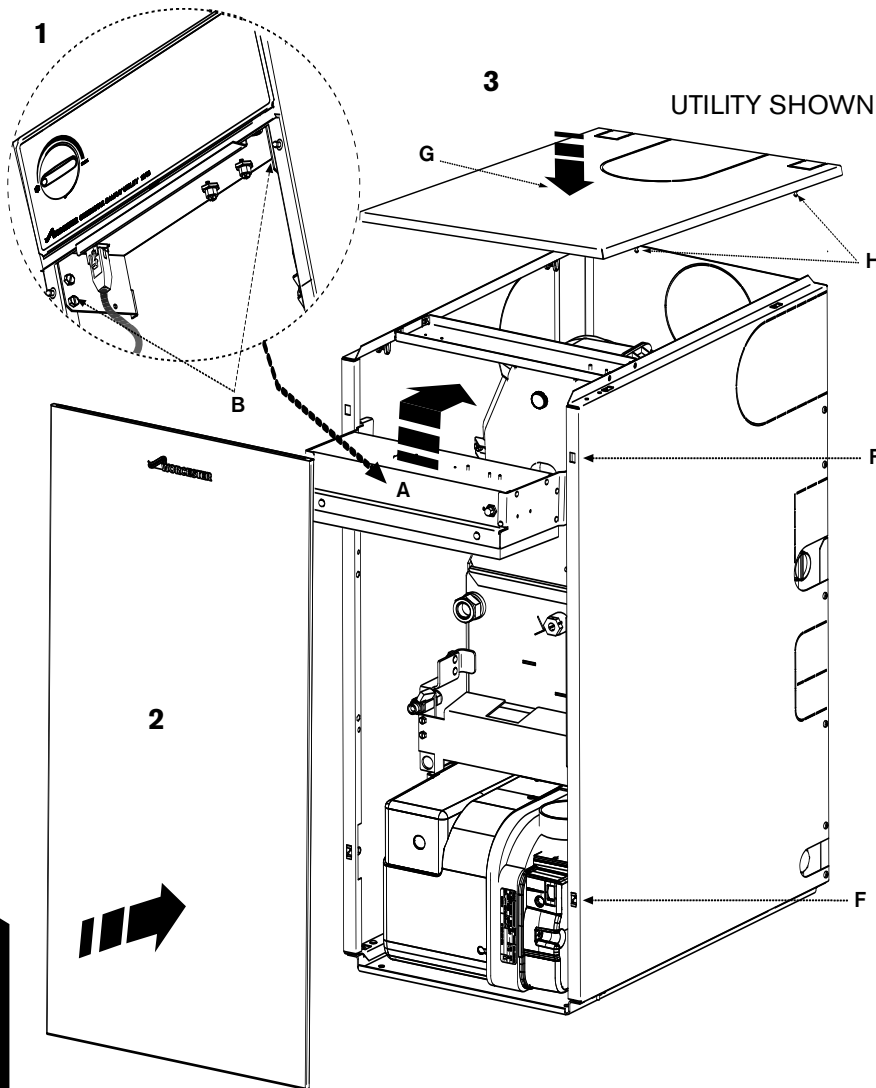

- 1 ▶ Pivot the control box (A) up and into the boiler.
- ▶ Secure with screws (B).

(Utility system only):

- ▶ In the case of the Utility System boiler, Replace the expansion vessel securing bracket and secure in place with the two screws (C).
 - ▶ Carefully replace the expansion vessel (D) by sliding up and in then down so that it comes to rest on the bracket, push the top of the vessel to the left to locate it in the top support bracket and tighten the securing screw (E). Take care not to kink or trap the flexible hose.
- 2 ▶ Locate the ball stud connections at the sides of the front panel and push towards the boiler to secure in their connectors (F).
- 3 ▶ Locate the top panel (G) onto the ball stud connections (H) and press down to secure.
Always apply pressure at the edges of the boiler panels when securing to avoid accidental damage.

UTILITY SYSTEM ONLY

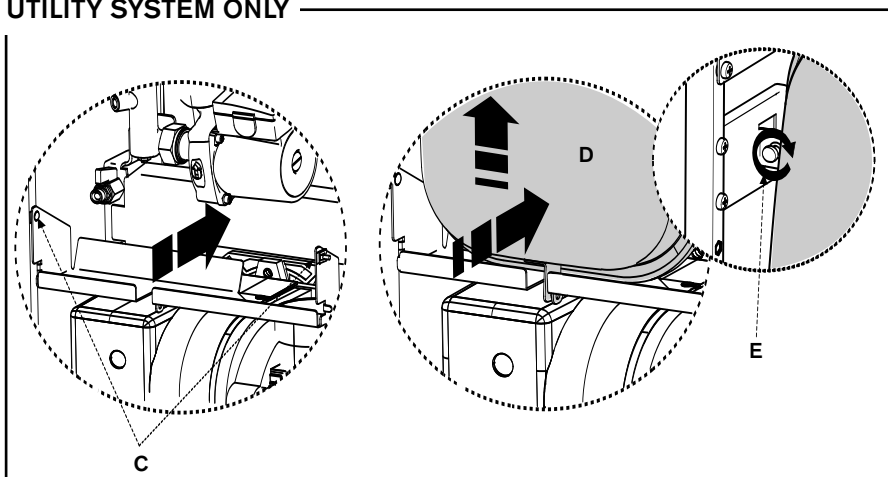

Handover:

- ▶ Complete the Guarantee Registration Card, Combustion Record (page 50) and CD11 or an equivalent commissioning form.
- ▶ Set up the controls and show the user how to operate all the controls shown in the User Guide and all system controls.
- ▶ Where applicable, instruct the customer how to repressurise the system.
- ▶ If the appliance is unused and exposed to freezing conditions, shut off all the mains supplies and drain the system and boiler.

NOTE: Release drain point (H) to drain the secondary heat exchanger.

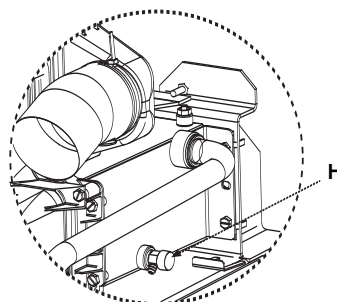

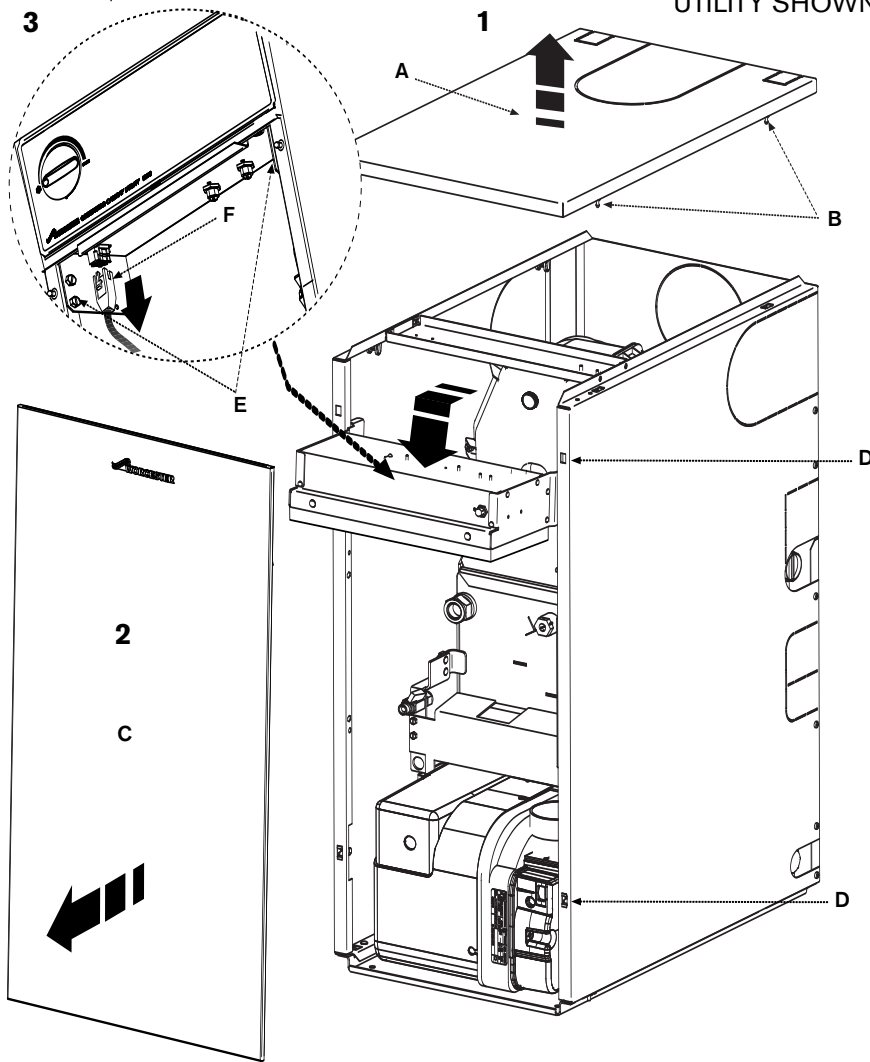

CAUTION: ISOLATE THE WATER, ELECTRICITY AND OIL MAINS SUPPLIES BEFORE STARTING ANY WORK AND OBSERVE ALL RELEVANT SAFETY PRECAUTIONS.

Routine servicing:

To maintain efficient boiler operation, the following should be carried out at least once a year.

▶ Carry out a pre-service check and note any operational faults:

▶ **Pre-Service Check:**

- 1 ▶ Lift the top panel (A) upwards to disengage the ball stud connections (B) and remove.
- 2 ▶ Pull front panel (C) away from the boiler to disengage ball stud connectors from their locations (D) and store safely away from the working area.
- 3 ▶ Remove securing screws (E) from each side of control box.
 - ▶ Pivot control box downwards into the service position as shown.

Operate the appliance and system and note any faults which may need to be corrected during the service.

- ▶ Switch off and electrically isolate the boiler.
- ▶ Depress locking ears and unplug burner lead (F) from control box.

4 Utility System only:

- ▶ In the case of the Utility System boiler, loosen the expansion vessel clamping screw (G) and move the vessel to the right to clear the top support. Lift the vessel (H) and move the base down and out to remove.
 - ▶ Stand the expansion vessel (H) on the floor next to the appliance.
 - ▶ Remove the two screws (I) securing the expansion vessel retaining bracket and remove it from the appliance.
- 5 ▶ Loosen clip (J) to detach air duct pipe.
 - ▶ Undo the two screws securing the deflector plate (K) and remove the plate.
 - ▶ Unscrew burner retainer nut (L) and gently pull burner forward so that the retainer (M) is free of the lug (N).

See the following instructions for detail of some of the service requirements listed below:

- ▶ Check and clean the burner.
- ▶ Replace burner nozzle and flexible oil pipe/s.
- ▶ Check and clean the baffle retainers.
- ▶ Check and clean the baffles.
- ▶ Check and clean the heat exchanger surfaces.
- ▶ Check the combustion chamber access door insulation board.
- ▶ Check that the flue system is unobstructed and clean as necessary.
- ▶ Clean or replace all oil filters.
- ▶ Check that the condensate system is not obstructed, clean and refill the condensate trap as necessary.

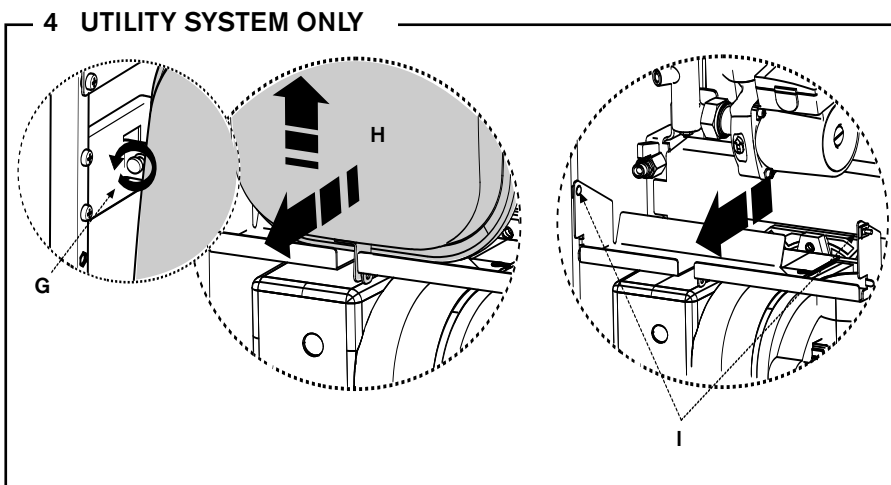

SERVICING & SPARES

1 Clean the Burner:

- ▶ Remove the air intake cover (A) and clear any debris from the air intake and air damper.
- ▶ Disassemble the burner to allow access to the fan impeller.
- ▶ Check the condition of the gaskets between these parts and replace if necessary.
- ▶ Note the position of the air damper adjustment and check the air damper moves freely.
- ▶ Clean both sides of the fan impeller and remove any debris from the burner housing.
- ▶ Check that the impeller rotates freely.
- ▶ Reassemble the components.
- ▶ Remove the combustion head (B) and thoroughly clean any deposits.

IMPORTANT: Before removing or fitting a nozzle (C), loosen screw (D) and move the electrodes (E) forward.

After refitting check that the electrode gaps are correct, as shown opposite.

- ▶ Remove the nozzle (C).
- ▶ Check the nozzle holder is clear of any debris and clean if necessary.
- ▶ Fit a new oil atomising nozzle (C).

DO NOT dismantle the nozzle and DO NOT clean the nozzle tip.

- ▶ Check the electrodes (E) and reset if necessary as shown opposite.

NOTE: The 12/18 model has a brass air deflection washer and locating circlip behind the nozzle. These must be in place for the correct operation of the burner.

- ▶ Refit the combustion head (B). Check that the nozzle (C) lies central to the combustion head (B) and the head settings are as shown. Ensure that the photocell is lined up with the sight hole.
- ▶ Withdraw the photocell (F) from its housing and wipe clean.
- ▶ Remove the oil pump internal filter, clean in kerosene and reassemble.

The internal filter is accessed by removing screws (G) and the oil pump cover (H).

- ▶ Replace the standard flexible oil line/s at every annual service to prevent the possibility of leakage due to ageing.
- ▶ Reassemble the burner components.
- ▶ Check the O-ring seal located around the combustion head and replace if necessary. **This seal must be in good condition, seal failure will cause flue gases to escape into the room.**

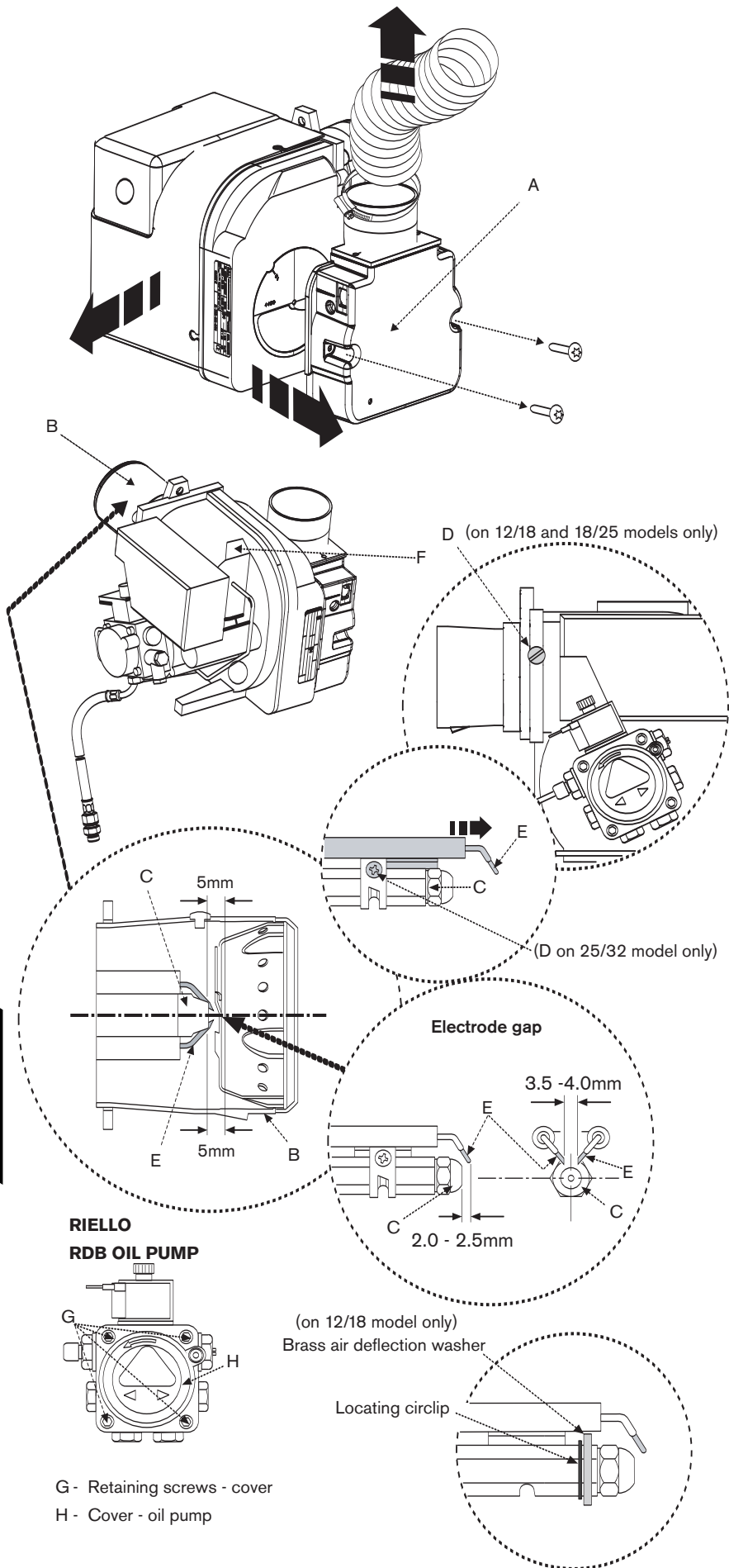

**RIELLO
RDB OIL PUMP**

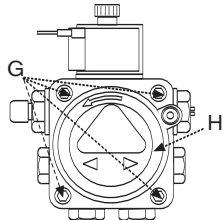

G - Retaining screws - cover
H - Cover - oil pump

(on 12/18 model only)
Brass air deflection washer

Locating circlip

External oil filter:

- ▶ Remove the paper element from the external oil filter and replace it. If the filter contains a washable element, thoroughly clean in kerosene and reassemble into the filter.

Clean the boiler:

Manifold access:

- ▶ Release screws (A) to remove the flue manifold access cover (B) and remove any debris.
 - ▶ Check the condensate route (C) is clear and clean the condensate trap and pipework.
 - ▶ Check the flue system and clean if necessary.
 - ▶ Remove the baffle retainer (D) and baffles (E) from the secondary heat exchanger.
 - ▶ Check and clean the secondary heat exchanger surfaces.
- NOTE: Do not use wire brushes and cleaning agents to clean the stainless steel secondary heat exchanger components.*
- ▶ Pour 500ml of water into drain (F) to refill the condensate trap.
 - ▶ Clean the secondary heat exchanger baffles (E) if necessary and refit correctly.
 - ▶ Refit the baffle retainer (D).
 - ▶ Check the seal on the manifold access cover (A) and replace if necessary.
 - ▶ Refit the flue manifold access cover (A) and secure with screws (B).

Combustion chamber:

- ▶ Release the M10 retaining nuts and washers (1) and remove combustion chamber access door (J).
- ▶ Check the fibreglass rope seal on the combustion chamber access door (J) and replace if necessary.
- ▶ Remove the 2 screws (K) and baffle access panel (L) located at the top of the primary heat exchanger and check the baffle retainers (M).
- ▶ Remove the baffles (N) and restrictor plate/s (O, not on 25/32 model), clean and check the condition of the baffles and the restrictor plate/s. Replace any parts considered to be badly corroded/degraded.
- ▶ Remove the acoustic insulation insert (P).
- ▶ Thoroughly clean all of the heat exchanger surfaces using a suitable brush and clear all loose debris from the combustion chamber and upper chamber.
- ▶ Check the condition of the combustion chamber access door insulation. If the insulation is damaged the door assembly must be replaced.
- ▶ Check the condition of the baffle access panel seal.
- ▶ Replace the acoustic insulation insert (P).
- ▶ Refit the items in reverse order ensure the baffles (N), baffle retainers (M) and restrictor plate/s (O, not on 25/32 model) are correctly fitted for the boiler output as shown in the plan view opposite.
- ▶ Refit baffle access panel (L).
- ▶ Refit combustion chamber access door (J).
- ▶ Secure with nuts and washers (1) and tighten until the door is firmly secured using the sequence shown opposite. Do not over tighten the nuts.

Fire valve:

- ▶ Check that the oil supply pipe has a fire valve fitted externally to the building with the fire valve sensor located within the appliance case. A fire valve sensor clip (Q) is provided for this purpose.

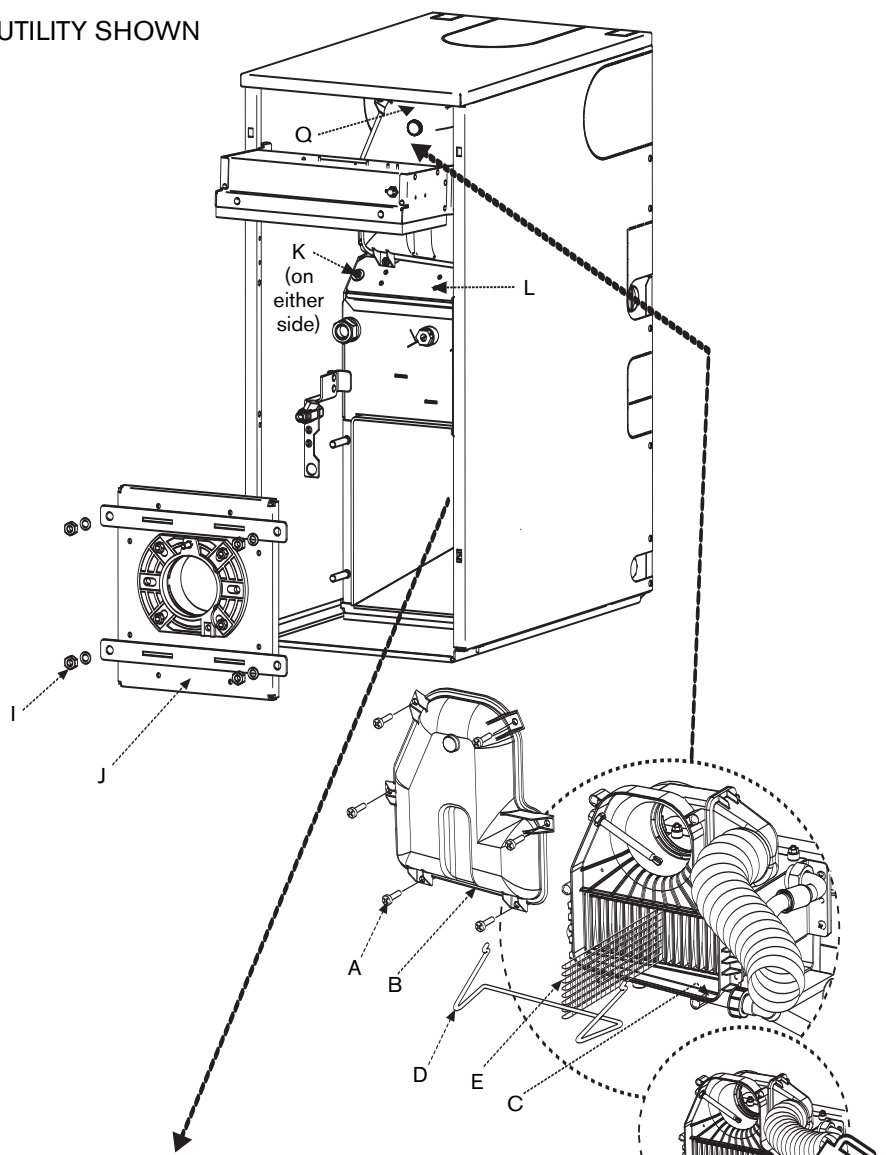

12/18
Plan sectional view

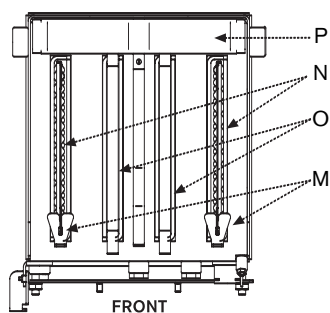

18/25
Plan sectional view

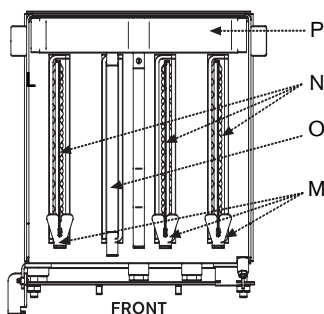

25/32
Plan sectional view

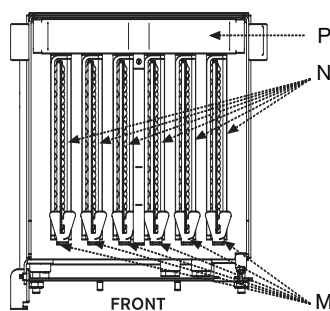

IMPORTANT when refitting the combustion chamber access door (6)

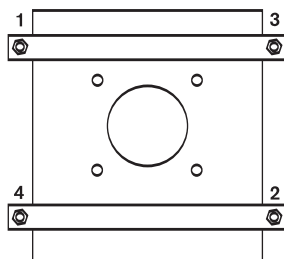

Combustion chamber access door tightening sequence.

SERVICING & SPARES

UTILITY SHOWN

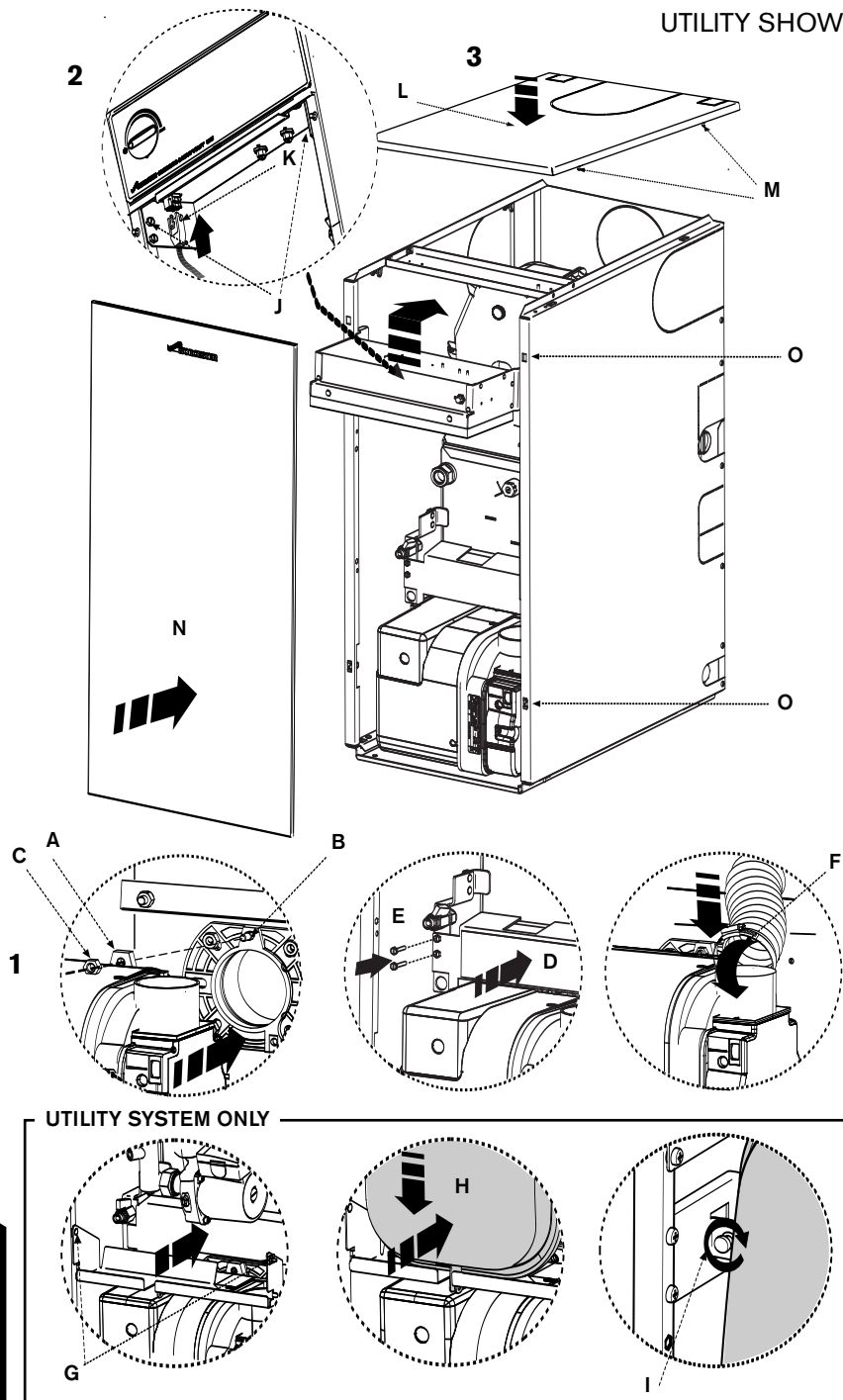

Re-commission the burner:

- 1 ▶ Align burner combustion head into boiler collar.
 - ▶ Locate the burner retainer (A) over the threaded lug on the collar (B). Push the burner firmly onto the flange and secure in place with the retaining nut (C). Tighten sufficiently but refrain from overtightening.
 - ▶ Check that the burner is seated correctly on its mounting flange and that the oil pipe/s are not trapped in front of or underneath the burner.
 - ▶ Refit the deflector plate (D) and secure with screws (E). Ensure that the flexible oil pipe/s are not positioned between the deflector plate and the combustion chamber door.
 - ▶ Attach air duct pipe and tighten clip (F) to secure to the burner air intake.

(Utility system only):

- ▶ In the case of the Utility System boiler, Replace the expansion vessel securing bracket and secure in place with the two screws (G).
- ▶ Carefully replace the expansion vessel (H) by sliding up and in then down so that it comes to rest on the bracket, push the top of the vessel to the left to locate it in the top support bracket and tighten the securing screw (I). Take care not to kink or trap the flexible hose.
- 2 ▶ Swing control box back up into operating position and retain in place by replacing the two securing screws (J) in the bottom locations.
 - ▶ Plug burner lead (K) into control box.
 - ▶ Run the burner and check the combustion settings as indicated in the table below and check that the smoke reading is between 0 - 1.
- 3 ▶ Replace top panel (L) making sure the ball studs (M) are located correctly by gently pressing down on the edges of the panel.
 - ▶ Replace the front panel (N) by gently pushing home the ball studs into their connections (O). Remember always to apply pressure to the edges of the panels to avoid damaging them.

SERVICING & SPARES

NOMINAL BOILER RATING AT NORMAL OPERATING TEMPERATURE USING 28sec KEROSENE

NOZZLE	OIL PUMP PRESSURE (p.s.i.)	FUEL FLOW RATE		APPROX. FLUE GAS TEMP °C	%CO ₂	APPROX. AIR SETTING	INPUT (APPLIANCE) kW	OUTPUT (APPLIANCE) kW	AIR DAMPER DISC SETTING	BURNER HEAD
		Kg/h	l/h							
Boiler 12/18 RDB 1										
0.40 60°ES	100	1.04	1.32	63	11.5	2.25	12.3	12.0	12	LD 2X SH 12/18
0.45 60°ES	120	1.28	1.63	67	11.5	2.5	15.4	15.0	15-18	LD 2X SH 12/18
0.55 x 80°EH	105	1.54	1.96	73	12.0	3.5	18.5	18.0	15-18	LD 2X SH 12/18
Boiler 18/25 RDB 2.2										
0.55 x 80°EH	105	1.55	1.96	75	11.0	3.5	18.5	18.0	18	T2 SH 18/25
0.60 60°ES	138	1.84	2.33	81	12.0	2.5	22.1	21.5	21.5-25	T2 SH 18/25
0.75 80°ES	120	2.15	2.72	81	12.5	4.5	25.7	25.0	21.5-25	T2 SH 18/25
Boiler 25/32 RDB 2.2										
*0.65 80°EH	140	2.15	2.72	80	11.0	4.5	25.7	25.0	N/A	T2 L/H 25/32
0.75 80°EH	125	2.37	3.0	81	12.0	4.0	28.3	27.5	N/A	T2 L/H 25/32
0.85 80°EH	125	2.58	3.27	83	12.5	4.5	30.8	30.0	N/A	T2 L/H 25/32

After service handover:

- ▶ Make a note of the date of any water treatment.
- ▶ Set the controls back to the users requirements.
- ▶ Complete the service interval record at the back of this manual and the CD11 or an equivalent form.
- ▶ If the appliance is unused and exposed to freezing conditions; shut off all the mains supplies, isolate the boiler and drain the system and boiler, including the secondary heat exchanger.

* 25/32 model for 25kW remove the plastic air guide (see page 36).

SHORT PARTS LIST 12/18

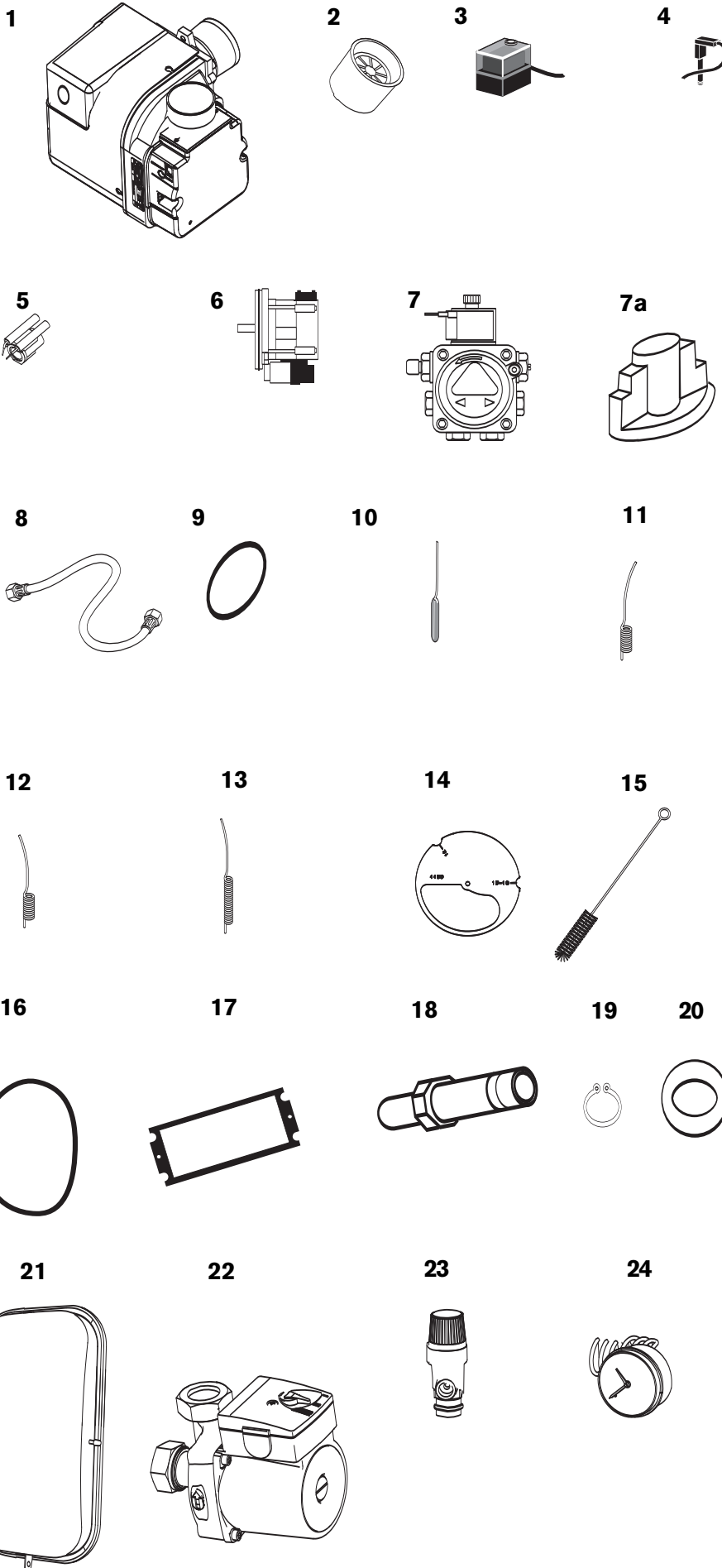

1 Burner - Riello RDB 1 12/18

Part Number: 8 716 111 951 0

2 Combustion head - LD2X SH12/18

Part Number: 8 716 112 731 0

3 Control box 535 RSE/LD

Part Number: 8 716 109 203 0

4 Photocell

Part Number: 8 716 109 193 0

5 Ignition electrode

Part Number: 8 716 109 183 0

6 Motor

Part Number: 8 716 109 186 0

7 Oil pump - Riello RDB

Part Number: 8 716 109 182 0

7a Pump coupling

Part Number: 8 716 109 245 0

8 Flexible oil line kit

Part Number: 8 716 106 346 0

9 Burner 'O' ring

Part Number: 8 716 109 328 0

10 Control thermostat

Part Number: 8 716 197 621 0

11 Auto reset high limit thermostat

Part Number: 8 716 107 623 0

12 Manual reset overheating thermostat

Part Number: 8 716 107 625 0

13 Manual reset flue overheating thermostat

Part Number: 8 716 107 624 0

14 Air damper disc 12 15-18

Part Number: 8 716 112 778 0

15 Cleaning brush

Part Number: 8 716 109 428 0

16 Manifold access cover seal

Part Number: 8 716 107 536 0

17 Secondary Heat Exchanger gasket

Part Number: 7 747 009 725 0

18 Nozzle holder

Part Number: 8 716 112 777 0

19 Circlip

Part Number: 8 716 112 773 0

20 Brass air restrictor washer

Part Number: 8 716 112 729 0

UTILITY SYSTEM ONLY

21 Expansion vessel

Part Number: 8 716 407 296 0

22 Pump

Part Number: 8 716 112 293 0

23 Pressure relief valve

Part Number: 8 716 142 422 0

24 System pressure gauge

Part Number: 8 716 112 729 0

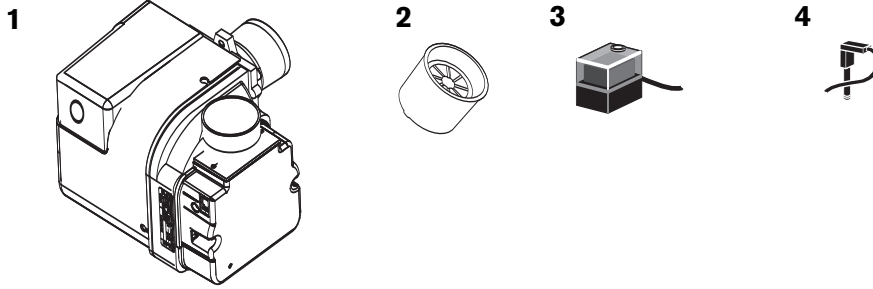

1 Burner - Riello RDB 2.2 18/25

Part Number: 8 716 112 346 0

2 Combustion head - T2 SH12/18

Part Number: 8 716 112 780 0

3 Control box 535 RSE/LD

Part Number: 8 716 109 203 0

4 Photocell

Part Number: 8 716 109 193 0

5 Ignition electrode

Part Number: 8 716 109 183 0



6 Motor

Part Number: 8 716 109 186 0

7 Oil pump - Riello RDB

Part Number: 8 716 109 182 0

7a Pump coupling

Part Number: 8 716 109 245 0

8 Flexible oil line kit

Part Number: 8 716 106 346 0

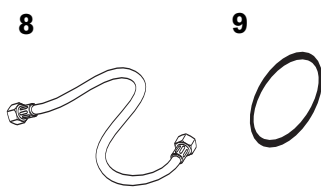

9 Burner 'O' ring

Part Number: 8 716 109 328 0

10 Control thermostat

Part Number: 8 716 197 621 0

11 Auto reset high limit thermostat

Part Number: 8 716 107 623 0

12 Manual reset overhear thermostat

Part Number: 8 716 107 625 0

13 Manual reset flue overhear thermostat

Part Number: 8 716 107 624 0

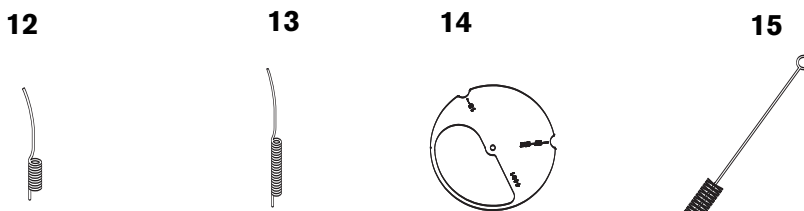

14 Air damper disc 18 21.5-25

Part Number: 8 716 112 783 0

15 Cleaning brush

Part Number: 8 716 109 428 0

16 Manifold access cover seal

Part Number: 8 716 107 536 0

17 Secondary Heat Exchanger gasket

Part Number: 7-747-009-725-0

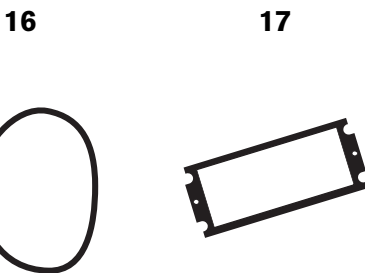

UTILITY SYSTEM ONLY

18 Expansion vessel

Part Number: 8 716 407 296 0

19 Pump

Part Number: 8 716 112 293 0

20 Pressure relief valve

Part Number: 8 716 142 422 0

21 System pressure gauge

Part Number: 8 716 112 729 0

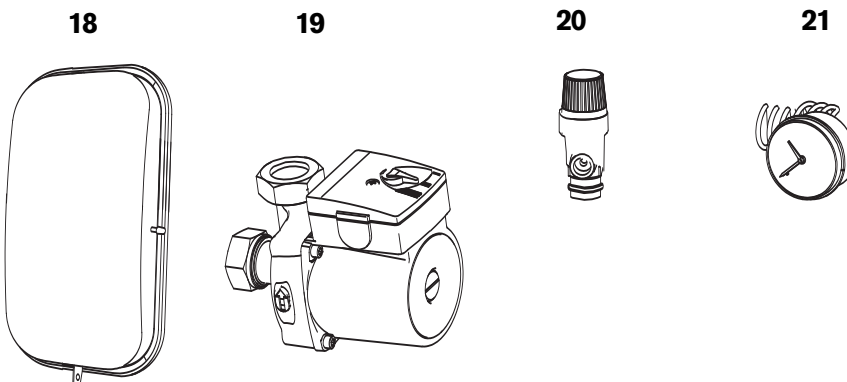

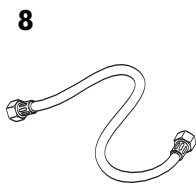
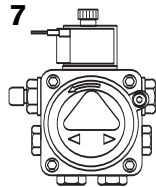
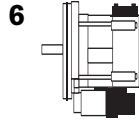
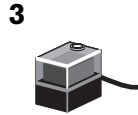
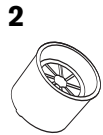
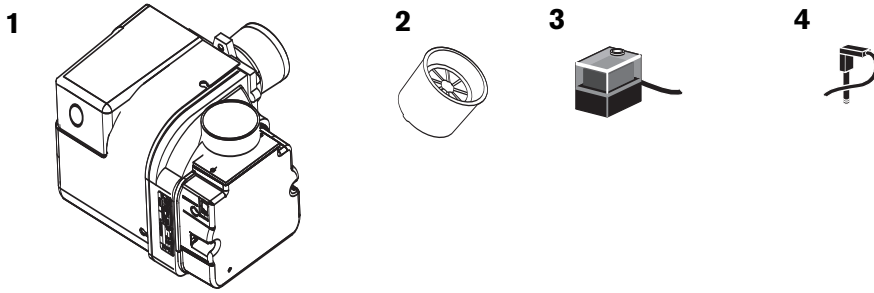

1 Burner - Riello RDB 2.2 25/32

Part Number: 8 716 112 347 0

2 Combustion head - T2 LH25/32

Part Number: 8 716 112 769 0

3 Control box 535 RSE/LD

Part Number: 8 716 109 203 0

4 Photocell

Part Number: 8 716 109 193 0

5 Ignition electrode

Part Number: 8 716 109 183 0

6 Motor

Part Number: 8 716 109 186 0

7 Oil pump - Riello RDB

Part Number: 8 716 109 182 0

7a Pump coupling

Part Number: 8 716 109 245 0

8 Flexible oil line kit

Part Number: 8 716 106 346 0

9 Burner 'O' ring

Part Number: 8 716 109 328 0

10 Control thermostat

Part Number: 8 716 197 621 0

11 Auto reset high limit thermostat

Part Number: 8 716 107 623 0

12 Manual reset overhear thermostat

Part Number: 8 716 107 625 0

13 Manual reset flue overhear thermostat

Part Number: 8716 107 624 0

14 Cleaning brush

Part Number: 8 716 109 428 0

15 Manifold access cover seal

Part Number: 8 716 107 536 0

16 Secondary Heat Exchanger gasket

Part Number: 7 747 009 725 0

UTILITY SYSTEM ONLY

17 Expansion vessel

Part Number: 8 716 407 296 0

18 Pump

Part Number: 8 716 112 293 0

19 Pressure relief valve

Part Number: 8 716 142 422 0

20 System pressure gauge

Part Number: 8 716 112 729 0

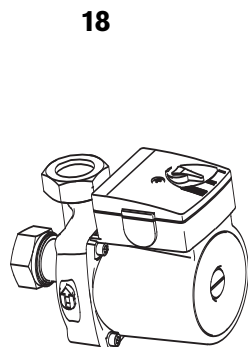
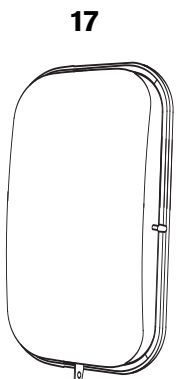
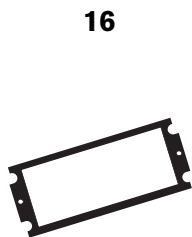

SERVICING & SPARES

PROBLEM	CAUSE	REMEDY
LOCKOUT:		
Pulsation on start	CF - Flue draught incorrect Combustion settings incorrect Faulty nozzle	CF - Check flue draught Set up as in installation instructions Replace nozzle
Intermittent lockout	Bad electrical connection Intermittent flame detection fault CF down draught	Check control box/electrical connections See flame detection fault CF Extend flue or fit an anti down draught cowl
Burner motor fails to operate	Faulty motor or electrical supply to motor Control box fault	Check for 230V to motor during startup period Replace control box
Flame detection fault	Photocell filmed over (dirty) Photocell faulty Control box faulty	Clean Replace Replace
Incorrect CO ₂	Air adjustment fault Oil pressure incorrect	Set up as in installation instructions Set up as in installation instructions
No oil from nozzle	No oil at pump Air in pump Nozzle blocked Faulty pump or drive coupling	Check and refill oil tank/bleed oil line Check and clean filters & valves from oil tank to boiler Bleed pump Replace nozzle Replace
Ignition failure	Electrode settings incorrect Faulty ignition transformer Open circuit ignition Faulty control box or electrical connections not properly made	Set up as in installation instructions Replace control box Check and replace electrodes or high tension leads if necessary Correct electrical control box connections or replace control box
BURNER FAILS TO START:		
	No power to boiler	Check electrical / control circuit
	Faulty boiler thermostat	Check by temporarily linking out high limit and control thermostats
	Programmer open circuit	Check by temporarily linking out the programmer
	Faulty control box	Replace control box
HIGH SMOKE NUMBER:		
	Air intake/flue blocked	Check & clear air intake/flue
	Incorrect combustion settings	Set up as in installation instructions
	Oil pressure incorrect	Adjust to correct pressure
	Incorrect components used on combustion head	Check with installation instructions
	Faulty nozzle	Replace nozzle

FAULT FINDING

BOILER LOCKOUT :

Indicated by the illumination of the 'Lockout' indicator on the burner.
To reset, wait 2 minutes then press the lockout reset button.

PROBLEM	CAUSE	REMEDY	FAULT FINDING
FAULTY BOILER OPERATION:			
Noisy operation	Pump noise from air in pump or worn pump Worn motor bearings Fan out of balance	Bleed air from pump or replace pump Replace motor Replace fan	
Boiling	Faulty boiler thermostat Short circuit boiler thermostat Thermostat bulb not fully home in pocket No primary water circulation	Replace if necessary Temporarily take out of circuit to check Ensure bulb is pushed fully home Check system / circulating pump	
Short Cycling	Burner rating incorrect Boiler thermostat differential incorrect External controls not operating correctly	Correct burner rating Replace boiler thermostat Check and correct external controls	
OIL SMELLS:			
	Blocked flue, fumes on startup Oil soaked boiler, faulty burner operation, numerous lockouts Odour in boiler room, oil leaks from pipework, flexible hoses connections	CF - Check flue draught with gauge - Check seals/gaskets RS - Check seals/gaskets Rectify burner operation and lockouts Rectify oil leaks, replace components if necessary	

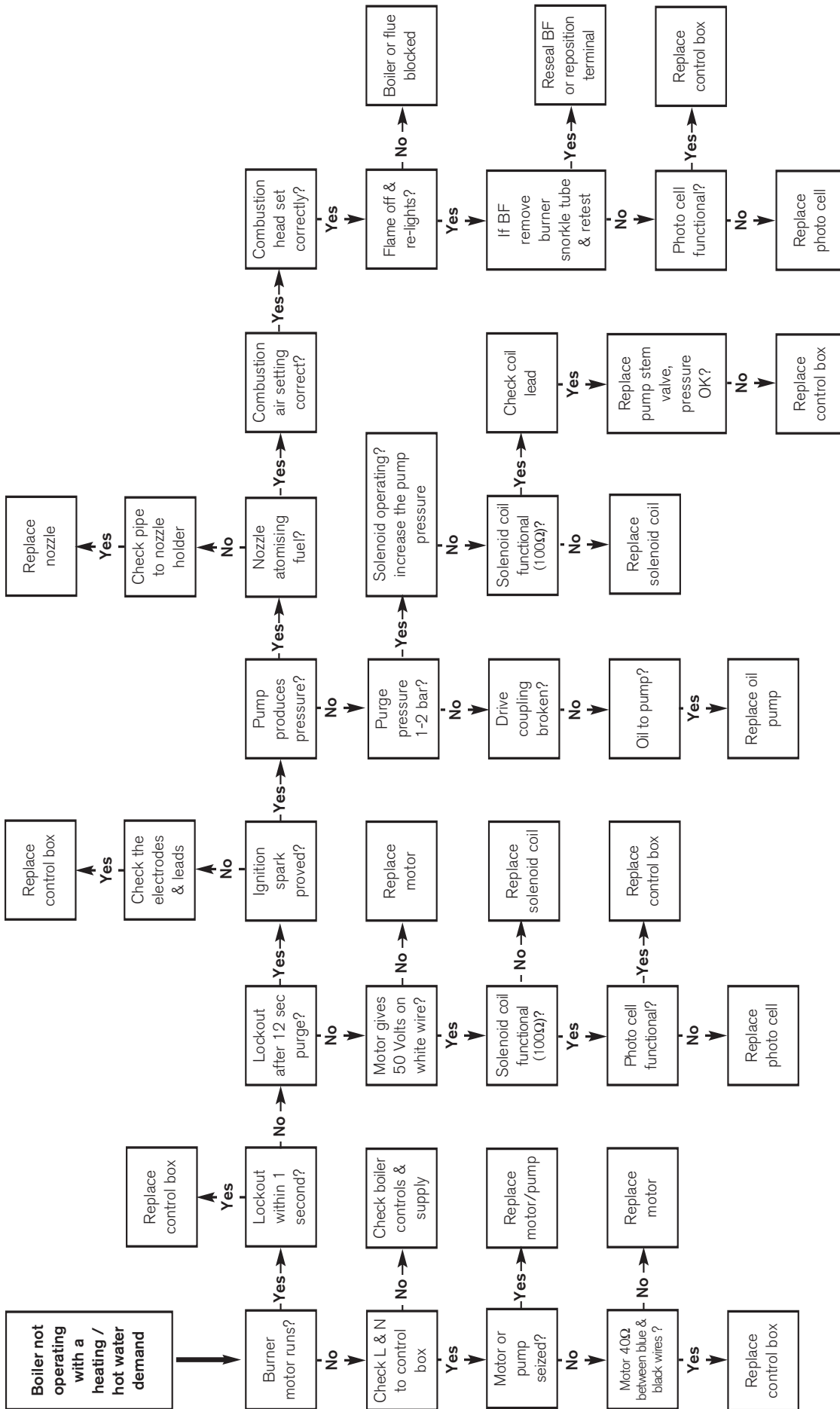

All resistance measurements are actual measured values and some variation is to be expected, therefore measured values should be similar to but not necessarily identical to the given values.

The operation of the photo cell can be tested by measuring the resistance across the photo cell, it should be a high resistance (greater than 10MΩ or open circuit) in the dark and low resistance (3KΩ or less) in light.

Burners on balanced flue systems can recirculate flue products resulting in the burner cycling, if this happens check the flue system integrity and the terminal position.

OIL BOILER COMBUSTION RECORD

BOILER MODEL _____ **SERIAL No.** _____

COMMISSIONING ENGINEER

COMBUSTION CHECKS

COMPANY NAME:	PUMP PRESSURE (PSI):
ADDRESS:	CO ₂ %:
_____	SMOKE READING:
ENGINEERS NAME:	F.G.T°C:
SIGNATURE:	FLUE PRESSURE:
DATE:	BURNER MODEL:

FOR ALL BOILERS CONFIRM THE FOLLOWING

THE CONDENSATE DRAIN HAS BEEN INSTALLED IN ACCORDANCE WITH THE MANUFACTURER'S INSTRUCTIONS	YES <input type="checkbox"/>
OIL TYPE USED IS 28 SECOND KEROSENE	YES <input type="checkbox"/>
THE SYSTEM HAS BEEN FLUSHED IN ACCORDANCE WITH THE INSTRUCTIONS?	YES <input type="checkbox"/>
THE SYSTEM CLEANER USED:	_____
THE INHIBITOR USED:	_____

SERVICE INTERVAL RECORD It is recommended that your heating system is serviced regularly and that you complete the appropriate Service Interval Record overleaf.

Service Provider. Before completing the appropriate Service Interval Record below, please ensure you have carried out the service as described in this manual. Always use Worcester, Bosch Group specified spare parts when replacing all controls.

SERVICE 1 DATE

ENGINEER NAME _____
 COMPANY NAME _____
 TEL No. _____
 OFTEC REG No. _____
 PUMP PRESSURE: psi CO₂%: _____
 NOZZLE CHANGED? YES NO
 F.G.T. °C FLUE PRESSURE: _____
 COMMENTS _____
 SIGNATURE _____

SERVICE 3 DATE

ENGINEER NAME _____
 COMPANY NAME _____
 TEL No. _____
 OFTEC REG No. _____
 PUMP PRESSURE: psi CO₂%: _____
 NOZZLE CHANGED? YES NO
 F.G.T. °C FLUE PRESSURE: _____
 COMMENTS _____
 SIGNATURE _____

SERVICE 5 DATE

ENGINEER NAME _____
 COMPANY NAME _____
 TEL No. _____
 OFTEC REG No. _____
 PUMP PRESSURE: psi CO₂%: _____
 NOZZLE CHANGED? YES NO
 F.G.T. °C FLUE PRESSURE: _____
 COMMENTS _____
 SIGNATURE _____

SERVICE 7 DATE

ENGINEER NAME _____
 COMPANY NAME _____
 TEL No. _____
 OFTEC REG No. _____
 PUMP PRESSURE: psi CO₂%: _____
 NOZZLE CHANGED? YES NO
 F.G.T. °C FLUE PRESSURE: _____
 COMMENTS _____
 SIGNATURE _____

SERVICE 9 DATE

ENGINEER NAME _____
 COMPANY NAME _____
 TEL No. _____
 OFTEC REG No. _____
 PUMP PRESSURE: psi CO₂%: _____
 NOZZLE CHANGED? YES NO
 F.G.T. °C FLUE PRESSURE: _____
 COMMENTS _____
 SIGNATURE _____

SERVICE 2 DATE

ENGINEER NAME _____
 COMPANY NAME _____
 TEL No. _____
 OFTEC REG No. _____
 PUMP PRESSURE: psi CO₂%: _____
 NOZZLE CHANGED? YES NO
 F.G.T. °C FLUE PRESSURE: _____
 COMMENTS _____
 SIGNATURE _____

SERVICE 4 DATE

ENGINEER NAME _____
 COMPANY NAME _____
 TEL No. _____
 OFTEC REG No. _____
 PUMP PRESSURE: psi CO₂%: _____
 NOZZLE CHANGED? YES NO
 F.G.T. °C FLUE PRESSURE: _____
 COMMENTS _____
 SIGNATURE _____

SERVICE 6 DATE

ENGINEER NAME _____
 COMPANY NAME _____
 TEL No. _____
 OFTEC REG No. _____
 PUMP PRESSURE: psi CO₂%: _____
 NOZZLE CHANGED? YES NO
 F.G.T. °C FLUE PRESSURE: _____
 COMMENTS _____
 SIGNATURE _____

SERVICE 8 DATE

ENGINEER NAME _____
 COMPANY NAME _____
 TEL No. _____
 OFTEC REG No. _____
 PUMP PRESSURE: psi CO₂%: _____
 NOZZLE CHANGED? YES NO
 F.G.T. °C FLUE PRESSURE: _____
 COMMENTS _____
 SIGNATURE _____

SERVICE 10 DATE

ENGINEER NAME _____
 COMPANY NAME _____
 TEL No. _____
 OFTEC REG No. _____
 PUMP PRESSURE: psi CO₂%: _____
 NOZZLE CHANGED? YES NO
 F.G.T. °C FLUE PRESSURE: _____
 COMMENTS _____
 SIGNATURE _____

NOTES

53

BAFFLE ARRANGEMENT DIAGRAM

12/18 UTILITY MODEL SHOWN

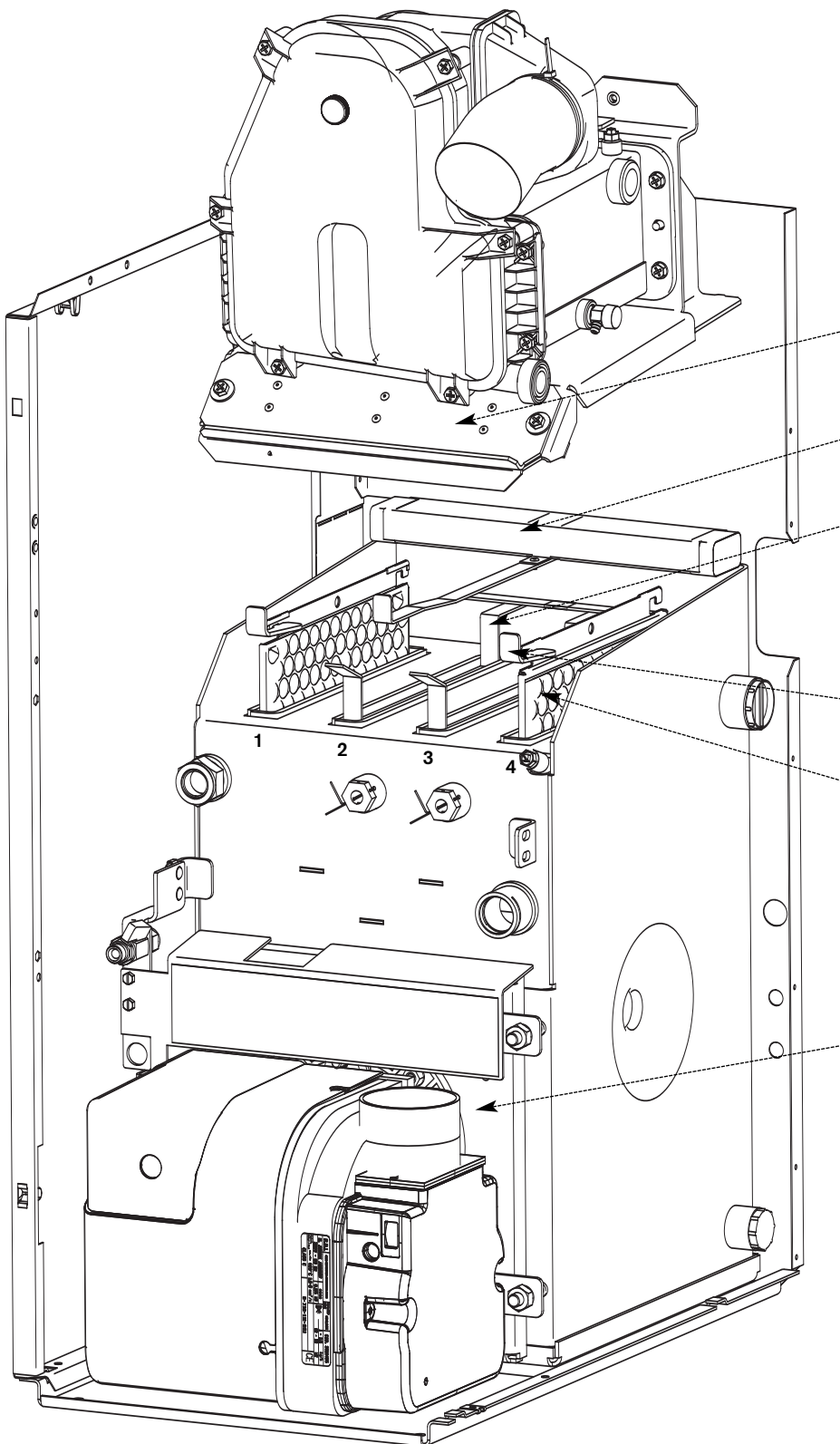

BAFFLE ACCESS DOOR

ACOUSTIC INSULATION INSERT
(All models)
Remove last. Refit first.

RESTRICTOR PLATE
(2 for 12/18 models, 1 for 18/25 models)
Remove and fit through baffle access door.
12/18 fitted into tubes 2 & 3.
18/25 fitted into tube 2.

BAFFLE RETAINER
Remove and fit through baffle access door.

BAFFLE
(2 for 12/18, 3 for 18/25 and 6 for 25/32)
Lift baffle to remove the baffle retainer then
pull down to remove the baffle through the
combustion chamber.
12/18 baffles in tubes 1 & 4.
18/25 baffles in tubes 1, 3 & 4.
25/32 baffles in all 6 tubes.

COMBUSTION CHAMBER ACCESS DOOR

BAFFLE
ARRANGEMENT
DIAGRAM

If in the unlikely event the boiler does not give complete satisfaction, before calling for a service engineer, the installer should check the following:-

General checks

1. Is there 230V across the boiler live and neutral terminals?
2. Is the polarity correct? (230V across live and earth, 0V across neutral and earth)
2. Is the air bled from the primary system?
3. Is the air bled from the oil supply?
4. Is the flue sized and routed correctly?

Boiler runs straight to lockout

1. Has the oil line been purged of air?
2. Where an air eliminator is used in conjunction with a top feed oil tank the non-return valve, (if fitted), should be removed from the oil dip pipe.

Boiler locks out at the start of a demand

(Heating off overnight for example)

1. If an air eliminator is being used, check that there are no leaks that allow air to be pulled into the oil supply.
2. If a two pipe oil supply is being used, has a non-return valve been fitted to the inlet pipe? Refer to the instructions for guidelines.

No domestic hot water

1. Is there a domestic hot water demand from the programmer and has the tank reached temperature?
2. Is the circulating pump operating?
3. Are the programmer, tank thermostat, circulating pump and diverter valve/zone valves wired correctly?
4. Is there 230V across L and N? If not there is no demand to the boiler from the controls or the controls wiring is not correct.

No central heating

1. Are both programmer and room thermostat on demand for central heating?
2. Are the room thermostat, programmer, circulating pump and diverter valve/zone valves (if CH and DHW system) wired correctly?
3. Is the circulating pump operating?
4. Is there 230V across L and N? If not there is no demand to the boiler from the controls or the controls wiring is not correct.

EXCELLENCE COMES AS STANDARD

Worcester, Bosch Group
Cotswold Way, Warndon, Worcester WR4 9SW.
Tel. 01905 754624 Fax. 01905 754619
Worcester, Bosch Group is a trading name of
BBT Thermotechnology UK Ltd.
www.worcester-bosch.co.uk

8 716 113 004a (02.07)

CONTACT INFORMATION

WORCESTER, BOSCH GROUP:

TECHNICAL: 08705 266241
SERVICE: 08457 256206
SPARES: 01905 752571
LITERATURE: 01905 752556
TRAINING: 01905 752526
SALES: 01905 752640
WEBSITE: www.worcester-bosch.co.uk

WATER TREATMENT:

FERNOX 01799 550811
www.fernox.com
SENTINEL 0151 420 9595
www.betzdearborn.com/sentinel

FLUE TERMINAL GUARD:

PART No. 7 716 190 050



WORCESTER
Bosch Group