



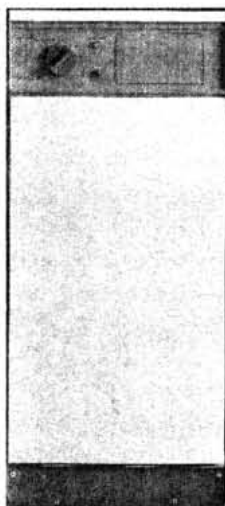
Bosch Group

DANESMOOR

12/14, 15/19, 20/25, 26/32, 32/50, 50/70

CONVENTIONAL FLUE AND ROOM SEALED BF
FLOOR STANDING OIL-FIRED PRESSURE JET APPLIANCES

INSTALLATION AND SERVICING INSTRUCTIONS



Worcester Bosch supports the
Benchmark code of practice

BOILER OUTPUT

Hot Water and Central Heating

12/14	MINIMUM 12 kW (41,000 Btu/h)
	MAXIMUM 14 kW (48,000 Btu/h)
15/19	MINIMUM 15 kW (51,000 Btu/h)
	MAXIMUM 19 kW (65,000 Btu/h)
20/25	MINIMUM 20 kW (68,000 Btu/h)
	MAXIMUM 25 kW (85,000 Btu/h)
26/32	MINIMUM 26 kW (89,000 Btu/h)
	MAXIMUM 32 kW (109,000 Btu/h)
32/50	MINIMUM 32 kW (109,000 Btu/h)
	MAXIMUM 50 kW (170,000 Btu/h)
50/70	MINIMUM 50 kW (170,000 Btu/h)
	MAXIMUM 70 kW (239,000 Btu/h)

THESE INSTRUCTIONS APPLY TO UK MODELS ONLY

THESE INSTRUCTIONS ARE TO BE LEFT WITH THE APPLIANCE

Contents

1. Installation Regulations	Page 2
2. General Information	Page 2
3. Technical Data.....	Page 3
4. Siting the Appliance	Page 6
5. Removal of the Cabinet.....	Page 6
6. Air Supply.....	Page 6
7. Flue System.....	Page 9
8. Oil Supply	Page 12

9. Heating and Hot Water System.....	Page 16
10. Electrical	Page 16
11. Installation	Page 21
12. Commissioning the Appliance	Page 22
13. Instructions to the User	Page 26
14. Routine Cleaning and Inspection.....	Page 26
15. Short Parts List.....	Page 30
16. Fault Finding	Page 31

1. Installation Regulations

1.1 General installation information and advice may be obtained from the Oil Firing Technical Association for the Petroleum Industry (OFTEC). Training courses are also offered by OFTEC, leading to inclusion on their list of registered engineers.

1.2 The appliance should be installed by a competent person. The person installing the appliance should be aware of the Health and Safety at Work Act and take appropriate action to ensure that the regulations are adhered to. In order to give optimum efficiency and trouble free operation the appliance should be commissioned by a qualified engineer. OFTEC recommends the use of registered engineers for the commissioning of oil-fired burners.

1.3 The manufacturers notes must not be taken, in any way, as overriding statutory obligations.

1.4 The compliance with a British Standard does not, of itself, confer immunity from legal obligations. In particular the installation of this appliance must be in accordance with the relevant requirements of the following British Standards and regulations in respect of the safe installation of equipment.

BS 5410: part 1 & 2: Code of practice for Oil Fired Boilers.

BS 799: part 5: Specification for Oil Storage Tanks.

BS 7593: Code of Practice for treatment of water in domestic hot water central heating systems.

BS 5449: part 1: Specification for forced circulation hot water central heating for domestic premises.

BS 5955: part 8: Specification for the installation of thermoplastic pipes and associated fittings for use in domestic hot and cold water services and heating systems.

BS 7291: Thermoplastic pipes and associated fittings for hot and cold water for domestic purposes and heating installations in buildings.

BS 7074: part 1: Application, selection and installation of expansion vessels and ancillary equipment for sealed water systems.

BS 7671: IEE Wiring Regulations, current edition.

The Building Regulations Part J and L1 England and Wales; Part F and Part J Section III Scotland; Part L and Part F Northern Ireland.

Local water company bye-laws.

The Control of Pollution (Oil) Regulations.

1.5 To ensure that the installation will perform to the highest standards, the system and components should conform to those mentioned in the instructions.

2. General Information

benchmark The Benchmark initiative is the new code of practice to encourage the correct installation, commissioning and servicing of domestic central heating boilers and system equipment.

The 'Log-book' is a vital document that must be completed by the installer at the time of installation. It confirms that the boiler has been installed and commissioned according to the manufacturers instructions.

Without the completion of the Log-book, manufacturers may refuse to respond to a call-out from a householder, who will be advised that he or she must call back the installer, who has not fulfilled his obligations to record the information required by the initiative.

It is important that:

The services and the system are properly flushed as specified.

The User is clearly instructed on the correct operation of the appliance.

The benefits of regular servicing are explained - to maintain the efficiency and extend the life of the appliance.

2.1 These instructions cover both conventional flue (CF)/low-level discharge (LLD) and room sealed balanced flue (RS) appliances.

2.2 The Worcester Danesmoor range of appliances covered in these instructions has been designed to serve domestic central heating and hot water requirements ranging from 12 kW to 70 kW.

2.3 The RS balanced flue appliance forms a fully room sealed system by surrounding the burner with a unique, fully sealed, push fit box. This causes the combustion air to be drawn through a factory sealed air duct formed at the rear and underside of the boiler. The sealed burner cover gives excellent acoustic noise reduction and alleviates the need for an air brick to be located in the boiler room.

Because the balanced flue system does not rely on the cabinet panels to form the room seal, combustion readings can be taken from the flue outlet plate as on a conventional appliance, and the cabinet panels can be easily removed during installation thereby preventing any damage.

2.4 The boiler is factory set to the mid-range output and can be altered, if necessary, by adjusting the burner as specified in Tables 2 to 8. The low level discharge and room sealed 12/14, 15/19, 20/25 and 26/32 models are only suitable for use with 28 second Kerosene heating oil.

NOTE: It is a mandatory requirement of the building regulations that only 28 second kerosene is used on low level discharge flues.

2.5 The conventional flue 15/19, 20/25, 26/32, 32/50 and 50/70 models may be converted to burn 35 second gas oil by changing the nozzle and burner settings as specified in Tables 3,4,5,7 and 8.

2.6 A colour coordinated twin channel programmer can be fitted to the appliance fascia panel. This is available from Worcester, Bosch Group as an optional extra.

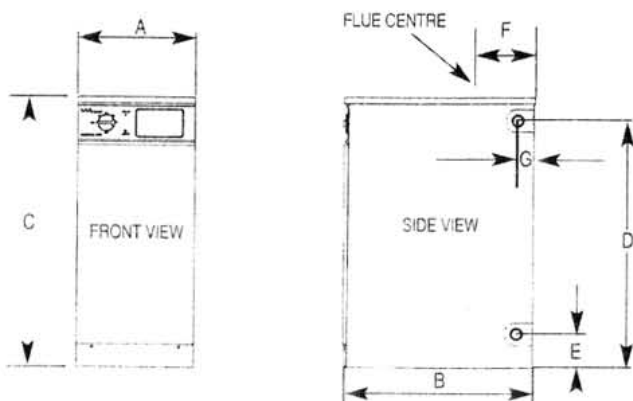
3. Technical Data

Table 1

SPECIFICATIONS							
Model		12/14	15/19	20/25	26/32	32/50	50/70
POWER SUPPLY		230V 50 Hz	230V 50 Hz	230V 50 Hz	230V 50 Hz	230V 50 Hz	230V 50 Hz
IP RATING		IP 20	IP 20	IP 20	IP 20	IP 20	IP 20
HEATING FLOW		1 in. BSP	1 in. BSP	1 in. BSP	1 1/4 in. BSP	1 1/2 in. BSP	1 1/2 in. BSP
HEATING RETURN		1 in. BSP	1 in. BSP	1 in. BSP	1 1/4 in. BSP	1 1/2 in. BSP	1 1/2 in. BSP
FUEL LINE		10mm Compression	10mm Compression	10mm Compression	10mm Compression	10mm Compression	10mm Compression
MINIMUM FLUE REQUIREMENT	CF	100mm (4 in.)	100mm (4 in.)	100mm (4 in.)	125mm (5 in.)	125mm (5 in.)	150mm (6 in.) up to 12m flue length 175mm (7 in.) for flue length over 12m
	RS	Balanced Flue Kit Section 7.3	Balanced Flue Kit Section 7.3	Balanced Flue Kit Section 7.3	Balanced Flue Kit Section 7.3	N/A	N/A
HEARTH TEMPERATURE		Below 100°C	Below 100°C	Below 100°C	Below 100°C	Below 100°C	Below 100°C
MAXIMUM STATIC HEAD		30m (98 ft.)	30m (98 ft.)	30m (98 ft.)	30m (98 ft.)	30m (98 ft.)	30m (98 ft.)
PRIMARY WATER CAPACITY		20 litres (4.4 gal.)	20 litres (4.4 gal.)	23.5 litres (5.2 gal.)	29.1 litres (6.4 gal.)	44.3 litres (9.8 gal.)	54 litres (11.9 gal.)
WEIGHT	CF	93 Kg (205 lbs)	96 Kg (212 lbs)	106 Kg (234 lbs)	138 Kg (306 lbs)	197Kg (434lbs)	244Kg (536lbs)
	RS	97 Kg (214 lbs)	100 Kg (220 lbs)	110 Kg (242 lbs)	142 Kg (313 lbs)	N/A	N/A
BURNER		Electro Oil Inter B9 A	Electro Oil Inter B9 B	Electro Oil Inter B11C	Electro Oil Sterling 40	Electro Oil B20 C	Electro Oil B20B
WATER SIDE RESISTANCE 10°C Difference		7 mbar	8 mbar	18 mbar	35 mbar	66mbar	195mbar
WATER SIDE RESISTANCE 20°C Difference		3 mbar	6 mbar	12 mbar	19 mbar	7mbar	10mbar
EXIT FLUE GAS MASS FLOW		24 kg/hr	35 kg/hr	43 kg/hr	57 kg/hr	85 kg/hr	115 kg/hr
SEDBUK RATING* (SEDBUK BAND C)		85.3%	85.5%	85.3%	85.3%	85.4%	85.2%
CONTROL THERMOSTAT RANGE	55°C minimum cut in to 82°C maximum cut out						
CONTROL THERMOSTAT DIFFERENTIAL	5°C						
HIGH LIMIT THERMOSTAT BREAK POINT	100 + 0/ - 6°C						
MANUAL RESET THERMOSTAT BREAK POINT	110 + 0/ - 6°C						

* The value is used in the UK Government Standard Assessment Procedure (SAP) for energy ratings for dwellings.

Fig. 1. Principal Dimensions (All Dimensions are millimeters)



MODEL	A	B	C	D	E	F	G
12/14	370	600	855	780	110	92	56
15/19	370	600	855	780	110	92	56
20/25	370	600	855	780	110	92	56
26/32	520	600	855	775	110	92	56
32/50	520	775	997	917	110	120	56
50/70	520	935	997	917	110	160	56

12/14 Table 2. Electro Oil Inter B9A Burner (See Fig. 23)

NOMINAL BOILER RATING AT NORMAL OPERATING TEMPERATURE											
Fuel	Nozzle ‡	Pump Pressure (p.s.i.) †	Fuel Flow Rate		Flue Gas Temp. (°C)**	%CO ₂	Approx. Air Setting	Appliance			
			Kg/h	l/h				Input		Output	
								kW	Btu/hr	kW	Btu/hr
28 Sec. Kerosene	0.40 60°ES	130	1.11	1.41	180	10	6	13.5	46,000	12	41,000
28 Sec. Kerosene	0.50 60°ES	100	1.30	1.64	195	11.5	7	15.5	53,000	14	48,000

15/19 Table 3. Electro Oil Inter B9B Burner (See Fig. 24)

NOMINAL BOILER RATING AT NORMAL OPERATING TEMPERATURE											
Fuel	Nozzle ‡	Pump Pressure (p.s.i.) †	Fuel Flow Rate		Flue Gas Temp. (°C)**	%CO ₂	Approx. Air Setting	Appliance			
			Kg/h	l/h				Input		Output	
								kW	Btu/hr	kW	Btu/hr
28 Sec. Kerosene	0.50 60°ES	110	1.40	1.77	215	10.5	8.5	17	58,000	15	51,000
28 Sec. Kerosene	0.55 80°EH	115	1.59	2.01	225	10.5	8.75	19	65,000	17	58,000
28 Sec. Kerosene	0.60 60°ES	105	1.78	2.25	235	11.5	9.0	21.5	73,000	19	65,000
35 Sec. Gas Oil*	0.50 80°S	155	1.80	2.12	235	11.5	9.0	21.5	73,000	19	65,000

20/25 Table 4. Electro Oil Inter B11C Burner (See Fig. 25)

NOMINAL BOILER RATING AT NORMAL OPERATING TEMPERATURE											
Fuel	Nozzle ‡	Pump Pressure (p.s.i.) †	Fuel Flow Rate		Flue Gas Temp. (°C)**	%CO ₂	Approx. Air Setting	Appliance			
			Kg/h	l/h				Input		Output	
								kW	Btu/hr	kW	Btu/hr
28 Sec. Kerosene	0.60 80°EH	130	1.87	2.37	190	11.0-11.5	5.5	22.5	77,000	20	68,000
28 Sec. Kerosene	0.75 80°EH	105	2.10	2.66	205	11.5-12.0	6.0	25	86,000	22.5	77,000
28 Sec. Kerosene	0.75 80°EH	130	2.34	2.96	220	12.0-12.5	6.5	28	96,000	25	85,000
35 Sec. Gas Oil*	0.60 80°S	120	2.13	2.51	205	11.5-12.0	6	25	86,000	22.5	77,000
35 Sec. Gas Oil*	0.60 80°S	150	2.37	2.79	220	12.0-12.5	6.5	28	96,000	25	85,000

26/32 Table 5. Electro Oil Sterling 40 Burner (See Fig. 26)

Conventional Flue Appliance (CF/LLD)

NOMINAL BOILER RATING AT NORMAL OPERATING TEMPERATURE											
Fuel	Nozzle ‡	Pump Pressure (p.s.i.) †	Fuel Flow Rate		Flue Gas Temp. (°C)**	%CO ₂	Approx. Air Setting	Appliance			
			Kg/h	l/h				Input		Output	
								kW	Btu/hr	kW	Btu/hr
28 Sec. Kerosene	0.85 80°EH	110	2.36	2.99	225	11.0-11.5	11	28.5	97,000	26	89,000
28 Sec. Kerosene	0.85 80°EH	130	2.66	3.37	240	11.0-11.5	12	32	109,000	29	99,000
28 Sec. Kerosene	1.00 80°EH	130	2.95	3.74	245	11.5-12.0	16	35.5	121,000	32	109,000
35 Sec. Gas Oil*	0.50 80°H	260	2.44	2.87	220	11.5-12.0	9	28.5	97,000	26	89,000
35 Sec. Gas Oil*	0.55 80°H	265	2.76	3.25	235	11.5-12.0	14	32	109,000	29	99,000
35 Sec. Gas Oil*	0.55 80°H	330	3.06	3.60	240	12.0-12.5	16	35.5	121,000	32	109,000

26/32 Table 6. Electro Oil Sterling 40 Burner (See Fig. 26)

RS Balanced Flue Appliance

NOMINAL BOILER RATING AT NORMAL OPERATING TEMPERATURE											
Fuel	Nozzle ‡	Pump Pressure (p.s.i.) †	Fuel Flow Rate		Flue Gas Temp. (°C)**	%CO ₂	Approx. Air Setting	Appliance			
			Kg/h	l/h				Input		Output	
								kW	Btu/hr	kW	Btu/hr
28 Sec. Kerosene	0.85 80°EH	110	2.36	2.99	225	11.0-11.5	10	28.5	97,000	26	89,000
28 Sec. Kerosene	0.85 80°EH	130	2.66	3.37	240	11.0-11.5	15	32	109,000	29	99,000
28 Sec. Kerosene	1.00 80°EH	130	2.95	3.74	245	11.5-12.0	20	35.5	121,000	32	109,000

32/50 Table 7. Electro Oil B20C Burner (See Fig. 27)

Conventional Flue Appliance (CF)

NOMINAL BOILER RATING AT NORMAL OPERATING TEMPERATURE											
Fuel	Nozzle ‡	Pump Pressure (p.s.i.) †	Fuel Flow Rate		Flue Gas Temp. (°C)**	%CO ₂	Approx. Air Setting	Appliance			
			Kg/h	l/h				Input		Output	
								kW	Btu/hr	kW	Btu/hr
28 Sec. Kerosene*	0.85 60°S	160	2.94	3.72	165	12.0-12.5	1	35.4	120,500	32	109,000
28 Sec. Kerosene*	1.20 60°S	150	3.77	4.76	190	12.0-12.5	2.75	45.3	154,500	41	140,000
#28 Sec. Kerosene*	1.35 60°S	150	4.6	5.81	220	12.0-12.5	4.75	55.3	188,500	50	171,000
35 Sec. Gas Oil*	0.85 60°S	210	3.82	4.6	190	12.0-12.5	2.75	45.3	154,500	41	140,000
35 Sec. Gas Oil*	1.0 60°S	260	4.66	5.61	210	12.5-13.0	6.5	55.3	188,500	50	171,000

At 50kW 28sec. Kerosene the airguide should be removed (See Fig. 27).

50/70 Table 8. Electro Oil Inter B20B Burner (See Fig. 28)

Conventional Flue Appliance (CF)

NOMINAL BOILER RATING AT NORMAL OPERATING TEMPERATURE											
Fuel	Nozzle ‡	Pump Pressure (p.s.i.) †	Fuel Flow Rate		Flue Gas Temp. (°C)**	%CO ₂	Approx. Air Setting	Appliance			
			Kg/h	l/h				Input		Output	
								kW	Btu/hr	kW	Btu/hr
28 Sec. Kerosene*	1.35 60°S	175	4.62	5.85	195	11.5-12.0	2.75	55.5	190,000	50	171,000
28 Sec. Kerosene*	1.75 60°S	140	5.55	7.03	210	12.0-12.5	4	67	229,000	60	205,000
~ 28 Sec. Kerosene*	2.00 60°S	135	6.47	8.19	225	12.5-13.0	4.5	78	268,000	70	239,000
35 Sec. Gas Oil*	1.00 60°S	245	4.69	5.52	195	11.0-11.5	2.75	55.5	190,000	50	171,000
35 Sec. Gas Oil*	1.35 60°S	175	5.63	6.62	210	12.0-12.5	4	67	229,000	60	205,000
~ 35 Sec. Gas Oil*	1.35 60°S	245	6.57	7.73	225	12.5-13.0	4.5	78	268,000	70	239,000

- NOTE: At 70kW the air guide should be removed (See Fig. 28)

* NOTE: For use on conventional flue only.

** NOTE: The flue gas temperature is measured in the gas sampling hole on the flue outlet plate. The probe should be inserted to a depth of 50mm and angled towards the flue outlet. The temperature measured is not an absolute flue gas temperature and is for general guidance purposes only!

† NOTE: The pump pressure given is for general guidance only as variations in nozzle output can be up to ± 15%. It is, therefore, essential that the air is adjusted to give the correct CO₂ value.

‡ NOTE: The nozzle type used on 28 Sec. Kerosene outputs are nozzles calibrated specifically for use with 28 Sec. Kerosene which gives less variation in nozzle output than the standard 35 Sec. Gas Oil nozzles. However, if a 28 Sec. Kerosene nozzle is not available at servicing or commissioning it is appropriate to install a 35 Sec. Gas Oil nozzle providing the output, spray angle and pattern of the nozzle is the same as the 28 Sec. Kerosene nozzle (e.g. 0.75 80°EH may be replaced with a 0.75 80°H).

4. Siting the Appliance

4.1 The appliance is not suitable for external installation unless a suitable enclosure is provided.

4.2 The appliance should be positioned on a non-combustible solid base as near to the flue location point as possible. Care should be taken to ensure that the appliance is level; use packing at the corners where necessary.

4.3 When fitting a LLD or RS model, the rear of the appliance must be positioned against an external wall such that the flue terminal can safely discharge the flue gases as described in Section 7.

4.4 The following clearances must be left to allow access for installation and servicing:

- (a) Above - 300mm
- (b) In front - 600mm
- (c) Right and left hand side – sufficient for panel removal and access to pipe connections where required.

5. Removal of the Cabinet

See Figs. 2 and 3.

For installation and servicing of the appliance the cabinet should be removed as follows:

5.1 Remove the cabinet top panel by lifting squarely upwards to release the four ball stud connections.

5.2 Remove the front panel by pulling the bottom of the panel forwards to release the ball studs and lifting the panel upwards and forwards to release from its supporting ledge.

5.3 The side panels are removed by firstly following procedures 5.1 to 5.2 as described above, then remove screw (A) from the side panel base and the three screws located in the upper flange of each side panel. Ease the panel clear of the electrical control box and slide forwards to release from the locating lugs on the base plate.

5.4 The control box can be removed by undoing the four screws in the top access cover and then removing the wing nut on the underside of the control box. The thermostat phials should be carefully removed from the phial pocket and the control box placed in a safe place taking care not to kink the thermostat capillary tubes.

5.5 On the RS balanced flue model, remove the burner box cover by pulling forwards to release the ball studs. This will be found easier by pulling on one side of the handle first to release two of the ball studs and then repeating on the other side. Take care not to pivot the remaining two ball studs too far around as this will cause damage to the spring clips.

6. Air Supply

OPEN FLUE MODEL (CF/LLD)

This includes conventional flue and standard low level and high level horizontal discharge kits.

6.1 In order to ensure clean and efficient combustion an adequate supply of air must be delivered to the combustion chamber. To provide sufficient air a suitable inlet should be provided into the room or space in which the boiler is situated, the sizes of which are given in Table 9. An air brick or other form of continuous air supply may have to be built into the installation in order to ensure an adequate supply of air.

6.2 If the appliance is to be installed in a confined space or compartment two air vents are required, one at high level and one at low level. The minimum free area of each vent is given in Table 10 and depends whether the air is taken from another room or

from outside the building. Where the air is taken from another room that room must contain an air inlet as described in 6.1.

6.3 There must be sufficient clearance around the appliance to allow proper circulation of ventilation air. The clearances required for installation and servicing will normally be adequate for ventilation. See Section 4.4.

ROOM SEALED BALANCED FLUE MODEL (RS)

6.4 The appliance does not require a separate vent for combustion air.

6.5 Installation in cupboards or compartments require permanent vents for cooling purposes, one at high level and one at low level, either direct to outside air or to a room. Both vents must pass to the same room or be on the same wall to the outside air. The minimum air vent free area is given in Table 11.

6.6 There must be sufficient clearance around the appliance to allow proper circulation of ventilation air. The clearances required for Installation and Servicing will normally be adequate for ventilation. See Section 4.4.

Table 9. Minimum Combustion Air Inlet Free Area for Open Flue appliances

APPLIANCE	AREA OF AIR INLET	
	cm ²	in. ²
12/14	77	12
15/19	105	16.5
20/25	138	21.5
26/32	176	27.5
32/50	275	43
50/70	385	60

Table 10. Minimum Air Vent Free Area for Open Flue appliances installed in a compartment.

Appliance model	Ventilation to room or internal space		Ventilation to outside	
	High Level	Low Level	High Level	Low Level
12/14	154cm ²	231cm ²	77cm ²	154cm ²
15/19	209cm ²	314cm ²	105cm ²	209cm ²
20/25	275cm ²	413cm ²	138cm ²	275cm ²
26/32	352cm ²	528cm ²	176cm ²	352cm ²
32/50	550cm ²	825cm ²	275cm ²	550cm ²
50/70	770cm ²	1155cm ²	385cm ²	770cm ²

Table 11. Minimum Air Vent Free Area for Room Sealed appliances installed in a compartment.

Appliance model	Ventilation to room or internal space		Ventilation to outside	
	High Level	Low Level	High Level	Low Level
12/14	154cm ²	154cm ²	77cm ²	77cm ²
15/19	209cm ²	209cm ²	105cm ²	105cm ²
20/25	275cm ²	275cm ²	138cm ²	138cm ²
26/32	352cm ²	352cm ²	176cm ²	176cm ²

Fig. 2. Conventional Flue Appliance (CF/LLD).

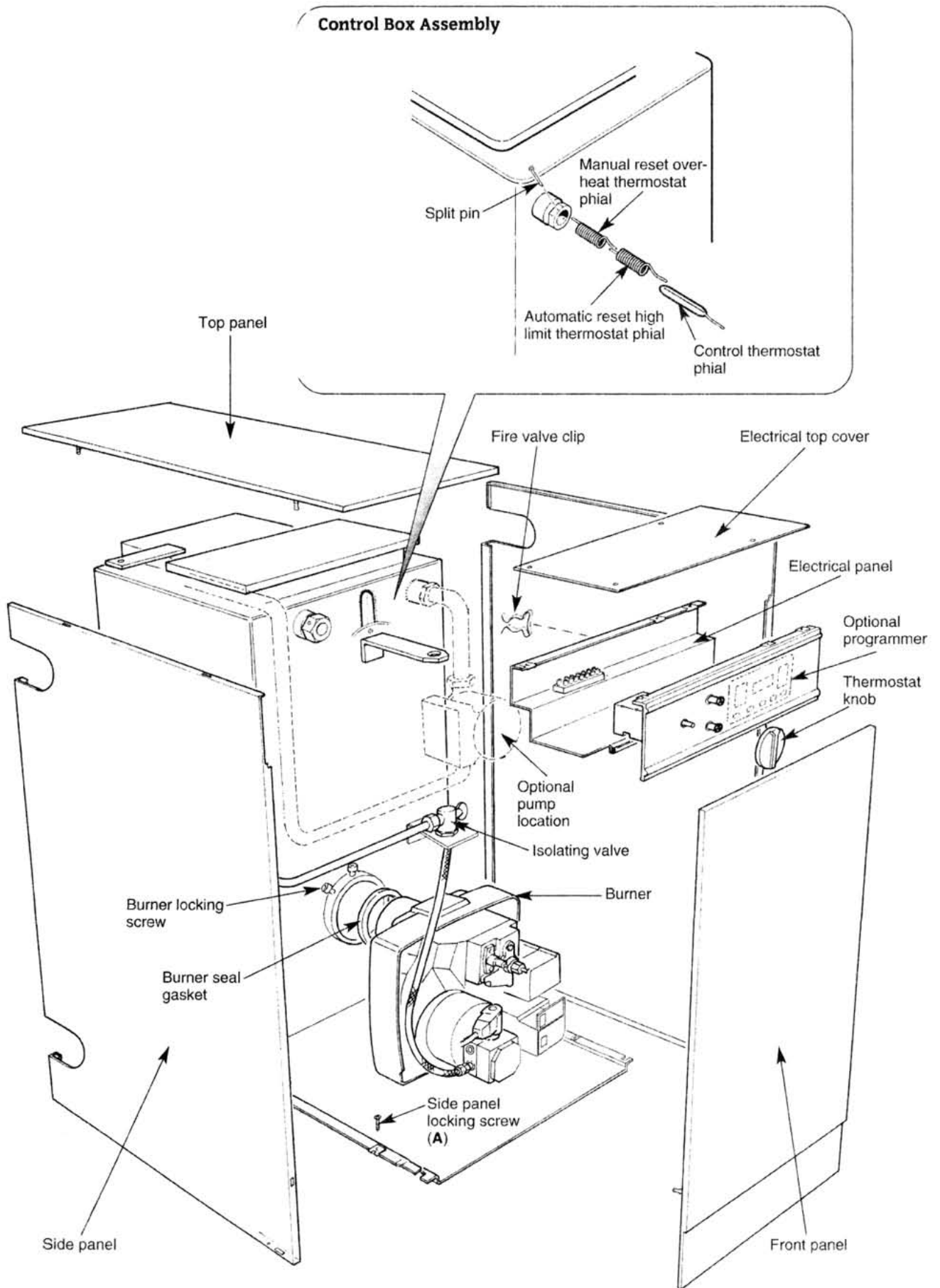
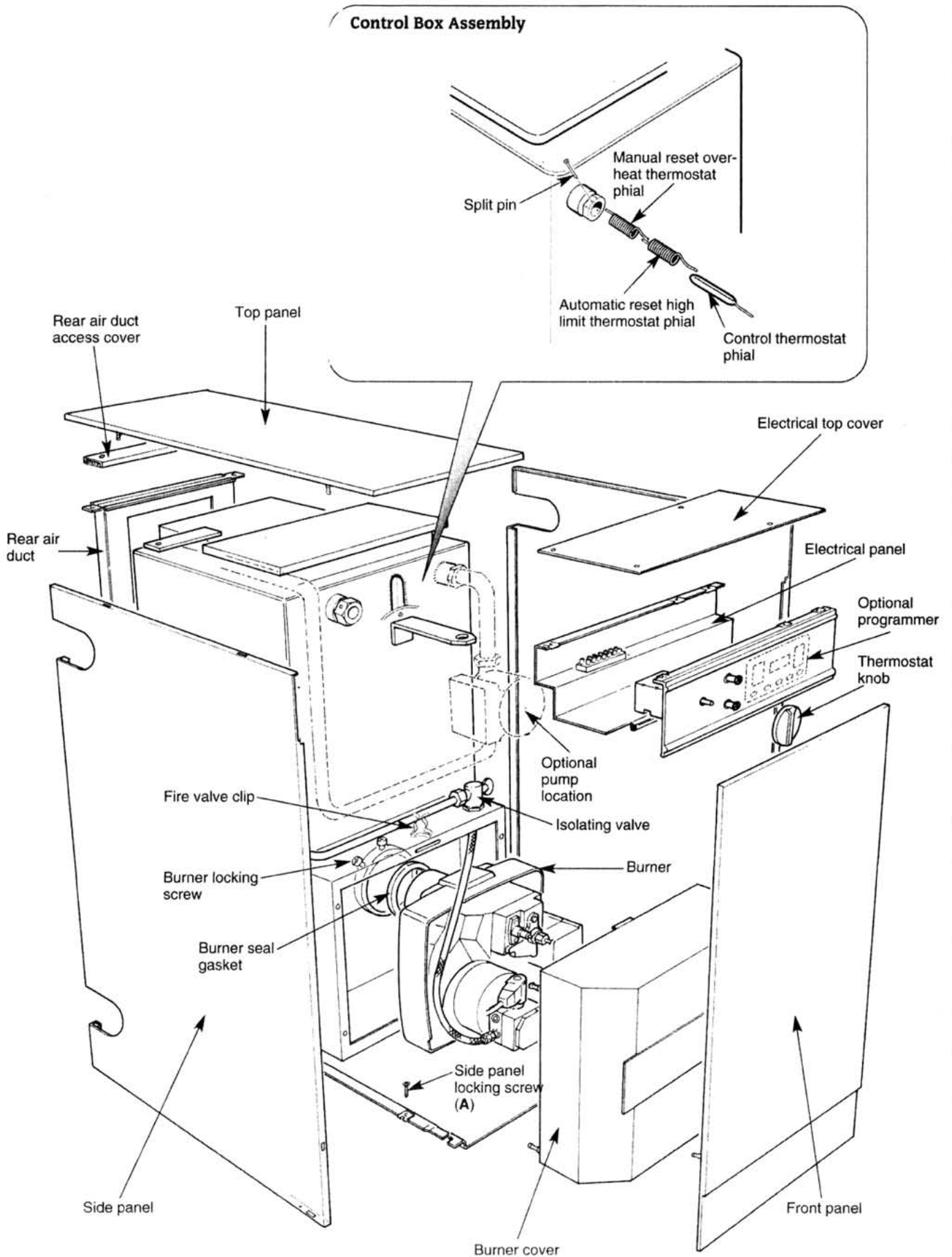


Fig. 3. Room Sealed Balanced Flue Appliance (RS).



7. Flue System

A flue system must be provided in accordance with BS5410:Parts 1 & 2 and the current Building Regulations.

7.1 CONVENTIONAL FLUE (CF).

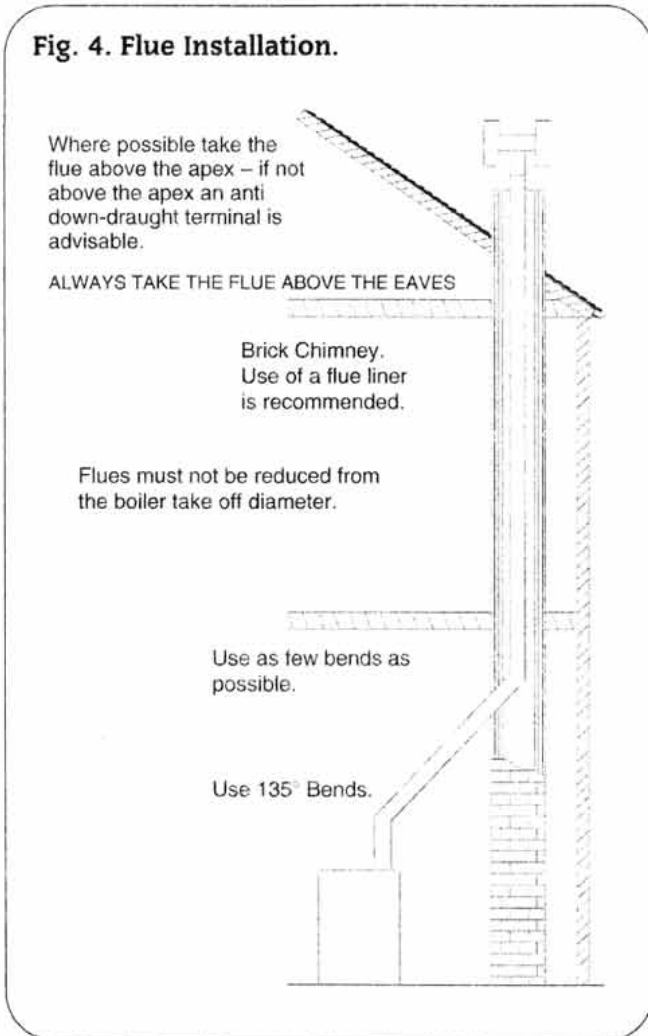
See Fig. 4.

Conventional Flue Diameters: 12/14 – 100 mm (4 in.)
 15/19 – 100 mm (4 in.)
 20/25 – 100 mm (4 in.)
 26/32 – 125 mm (5 in.)
 32/50 – 125 mm (5 in.)
 50/70 – 150 mm (6 in.)

NOTE: On 50/70 models with flue lengths longer than 12 meters it is recommended that 175mm (7in.) flue pipe is used from the boiler.

NOTE: External flues systems must be of the insulated flue type.

Fig. 4. Flue Installation.



The boiler is fitted with a conventional flue locating spigot. The flue pipe fits into the spigot and should be correctly sealed with fire cement.

NOTE: The size of the flue must never be reduced from the take-off diameter. An increase in flue size is permissible provided that the joint is sealed correctly.

When installed the flue should be vertical and contain as few bends as possible. Where bends are necessary, a maximum of two are permitted and 135 degree bends should be used.

All brick and masonry chimneys should be lined with a suitable non-combustible material, properly jointed and able to withstand the effects of the working temperature of the appliance and any condensate which may form.

Down-draught conditions will adversely affect the operation of the boiler and must be avoided. Where possible the flue should

be extended beyond the apex of the roof and should always be taken beyond the eaves of the building. Where down-draught is experienced a suitable anti down-draught terminal should be fitted to the flue termination.

The natural flue draught must be checked in the flue pipe immediately above the appliance or in the hole provided in the flue outlet plate. The flue draught should be no less than 0.75 mm W.g. and no greater than 5.1 mm W.g. If a flue draught greater than 5.1 mm W.g. is experienced a draught stabiliser should be introduced into the flue and adjusted to achieve a flue draught within the specified range.

7.2 Low Level Discharge

(See Fig. 5).

The conventional flue appliance may be converted to discharge the products of combustion at low level. For this purpose a special flueless kit and associated ducting is available, allowing the conventional flue to be discarded. Detailed instructions for converting the appliance to low level discharge are supplied with the conversion kit. The flue spigot should be removed from the flue outlet plate by undoing the three retaining screws and the hole blanked off with the plate provided in the kit.

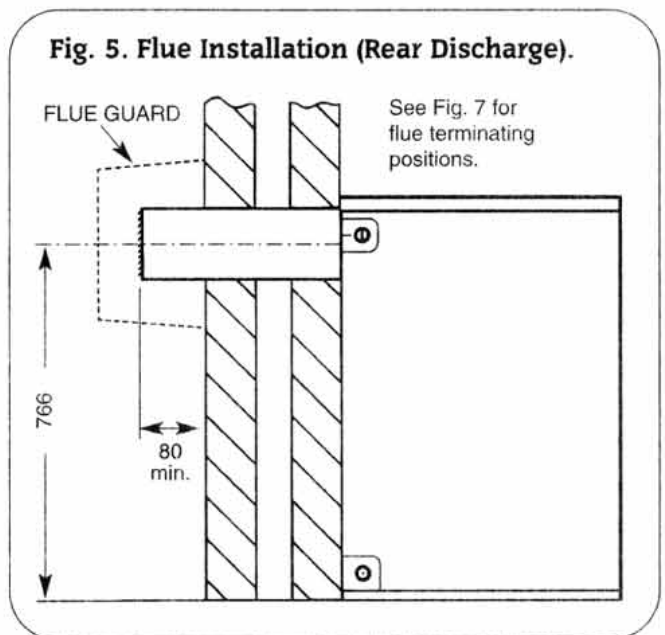
NOTE: Under no circumstances may 35 Second Gas Oil be burned with this type of flue terminal arrangement.

7.3 ROOM SEALED BALANCED FLUE MODEL (RS).

The appliance is supplied ready for installation as a low level discharge balanced flue system by the simple addition of one of the flue terminal kit options shown in Fig. 6.

Details of the installation procedure are included in the Flue

Fig. 5. Flue Installation (Rear Discharge).

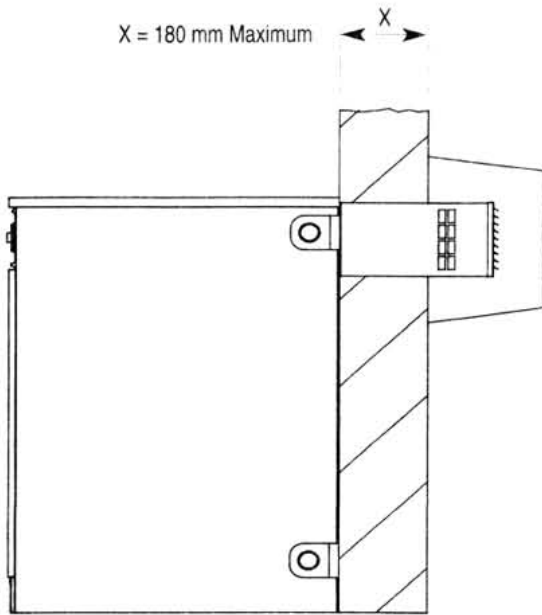


Terminal Instructions supplied with the terminal kit. Alternatively, a range of room sealed balanced flue kits are available to convert the appliance to discharge the flue products to the left, right, at a higher level, or vertically up to a roof height of 4.5 metres.

7.4 Siting the flue terminal

1. The flue terminal must be located in a suitable position, as shown in Fig. 7, such that the products of combustion can be freely dispersed without the possibility of the gases entering the dwelling or that of a neighbouring dwelling.
2. Discharge of flue gases into car ports or narrow passageways is not recommended.
3. The terminal must not cause an obstruction nor the discharge cause a nuisance as a result of either flue gases or terminal noise.
4. If the terminal is fitted within 1 m of a plastic or painted gutter or within 500 mm of painted eaves then an aluminium or stainless steel shield at least 1 m long should be fitted to protect the surface.

Fig. 6. Room Sealed Balanced Flue Terminal Installation.



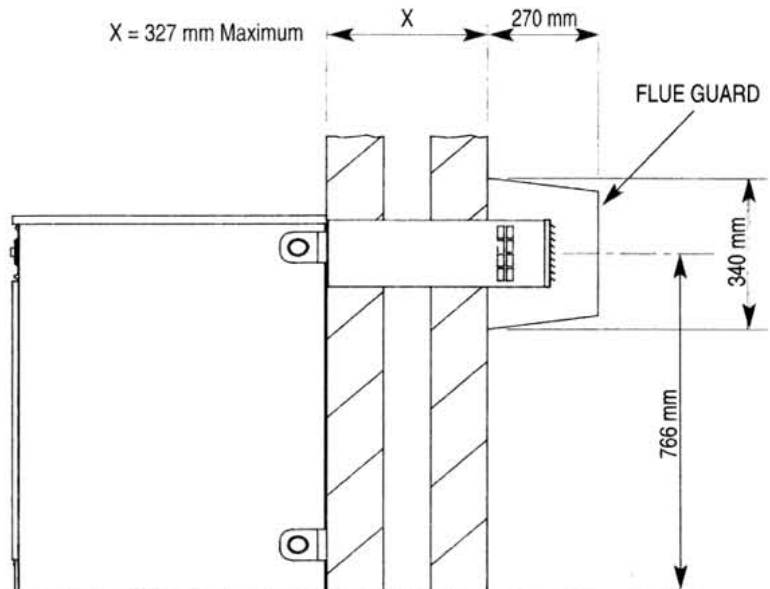
(a) Rear Discharge 4" to 7" Single Skin Wall.

For use with non-standard/single skin walls up to 182 mm thick.

Where noise emission from the flue terminal is likely to be of concern, it is recommended that the standard 12 in. terminal is used and the appliance stood away from the wall to take up the extra terminal body length.

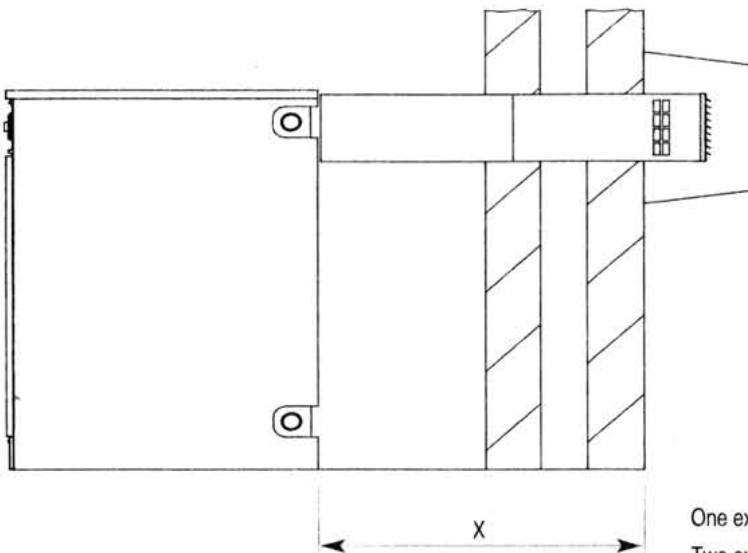
(b) Rear Discharge 7" to 12" Wall.

For use in standard cavity walls and solid walls up to 327 mm thick. This terminal offers maximum noise reduction of the flue gases. This terminal is designed for use with the extension kit.



(c) Rear Discharge Extension Kit 12" to 36" Wall.

For use where the wall thickness exceeds 327 mm or where the appliance is to be stood away from the wall as shown. The system uses a standard 12 in. RS Flue Terminal and up to two extension kits, which simply bolt together.



One extension kit - X = 638 mm Maximum
Two extension kits - X = 952 mm Maximum

5. If a terminal is fitted less than 2 metres above a surface to which people have access, fit a terminal guard as shown in Fig. 8. A suitable guard is available from Worcester, Bosch Group, Part Number 7 716 190 009, or alternatively a proprietary terminal guard may be used provided it has the minimum dimensions shown in Fig. 8.

The guard should have suitable corrosion resistance due to the acidic content of the flue gases.

6. The terminal guard must be evenly spaced about the flue terminal and secured using screws so that the terminal guard can be removed for maintenance to the flue terminal.

7. In certain weather conditions a terminal may steam and siting where this could cause a nuisance should be avoided.

8. Take care to ensure that combustion products do not enter ventilated roof voids.

Fig. 8. Terminal guard Minimum dimensions.

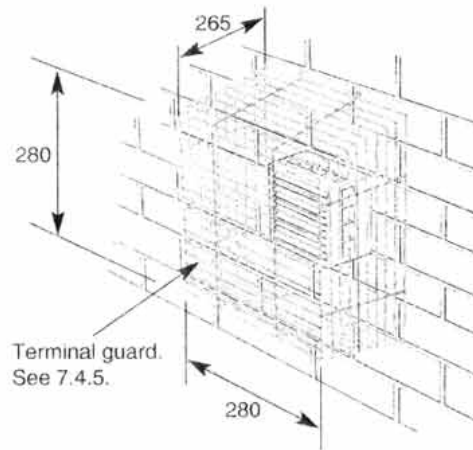
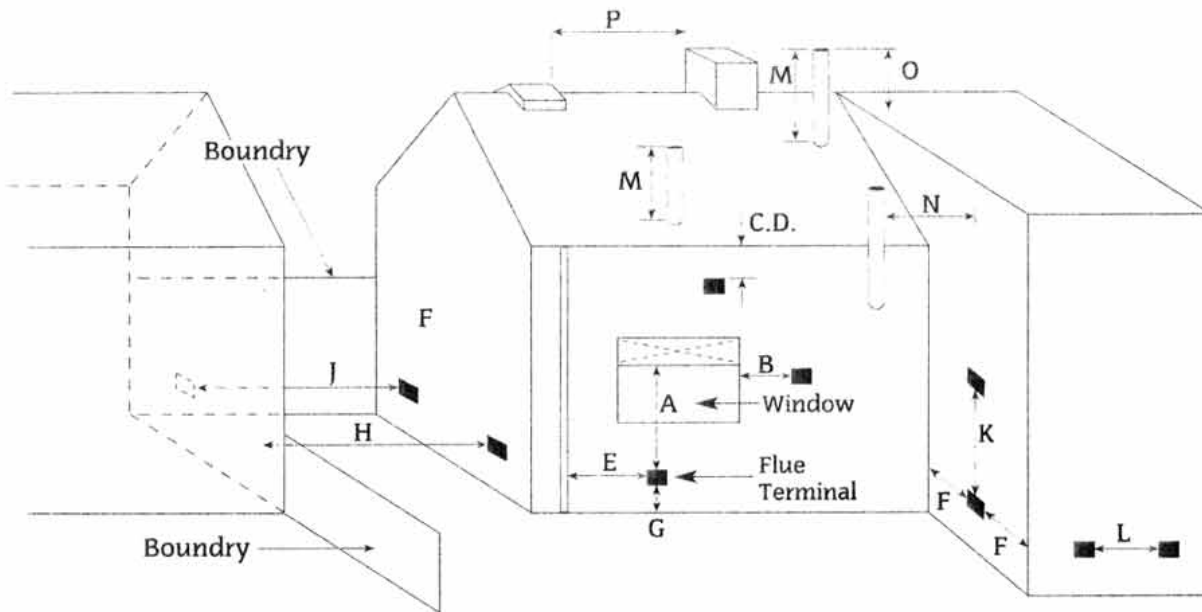


Fig. 7. Flue terminating positions for oil-fired appliances

NOTE: The dimensions given are for general guidance only. Other surrounding buildings or objects may affect the clearance of combustion products. An alternative flue terminal position should be sought when there is any possibility of a nuisance being caused by inadequate dispersal of flue products.

Terminals should be positioned so as to avoid products of combustion entering into buildings.



Terminal Position	Minimum Distance (mm)		
	Open Flue	Low-Level Discharge	Vertical Balanced Flue
A Directly below an opening, air brick, window, etc.	Not allowed	600	Not allowed
B Horizontally to an opening, air brick, window, etc.	Not allowed	600	"
C Below a gutter or sanitary pipe if combustible material protected.	Not allowed	75	"
D Below a balcony, eaves, gutter or drainage without protection to combustible material.	Not allowed	600	"
E From vertical sanitary pipework.	Not allowed	300	"
F From an internal or external corner or boundry along side terminal.	Not allowed	300	"
G Above ground or balcony level.	Not allowed	300	"
H From a surface or boundry facing the terminal.	Not allowed	600	"
J From a terminal facing the terminal.	Not allowed	1200	"
K Vertically from a terminal on the same wall.	Not allowed	1500	"
L Horizontally from a terminal on the same wall.	Not allowed	750	"
M Above an intersection with the roof.	600	Not applicable	732
N From a vertical structure on the side of the terminal.	750	Not applicable	750
O Above a vertical structure less than 750mm from the side of the terminal.	600	Not applicable	732
P From a ridge terminal to a vertical structure on the roof.	1500	Not applicable	Not applicable

8. Oil Supply

(See Figs. 9, 10 and 11).

8.1 Plastic or steel tanks should be installed to BS5410.

A steel tank should also conform to BS799: part 5 and be arranged with a slope of 1 in 24 away from the outlet valve with a sludge cock at its lower end.

8.2 Do not use galvanised steel tanks or pipework for the oil supply system.

8.3 Do not use soldered joints on the oil supply pipework as this could cause a hazard in the case of a fire.

8.4 The burners on all appliances are supplied so as to be connected to a single pipe gravity feed system. Details of how to convert the burners to a double-pipe sub-gravity feed system are shown in Fig. 9.

8.5 Oil Supply System

(a) Single Pipe System

If a single pipe system is employed then the tank must be positioned such that the oil level does not exceed 4 metres above the level of the burner oil pump and in addition the oil level must be at least 0.3 metres above the level of the oil pump. Should it prove impossible to site the tank below the 4 metres maximum oil level a head breaking device must be installed between the tank and the burner.

(b) Double Pipe System

If a double pipe system is used then the maximum suction height allowable is 3.5 metres.

(c) Single Pipe Suction Lift with De-aerator

If a single pipe suction lift with a de-aerator is used, the oil tank must be positioned below the burner. An inlet and return loop should be created between the de-aerator and oil pump. The oil pump should be connected as for a double pipe system. Details of how to convert to a double pipe system are shown in Fig. 9.

Oil inlet and return flexible hoses should be connected to the oil pump inlet and return ports.

Table 14 is a general guide to determine the maximum allowable pipe run when using a de-aerator.

Table 14 does not override the de-aerators manufacturers instructions and should only be used in conjunction with the manufacturers instructions.

If a non-return valve is not incorporated within the de-aerator unit, a non-return valve should be fitted in the oil line between the oil tank and the de-aerator.

NOTE: If a de-aerator is used it should be fitted externally to the building.

8.6 Oil Supply Pipework

a) The oil supply pipe diameter can be determined using Tables 12, 13 and 14 depending on whether a single or double pipe system or single pipe system with de-aerator is being installed. Selection of the correct pipe diameter will depend on the position of the oil storage tank relative to the burner and the length of the pipe run.

b) The oil supply pipe should be laid as level as possible to avoid air pockets and unnecessary friction losses.

c) The following components should be fitted in the fuel line between the storage tank and burner:

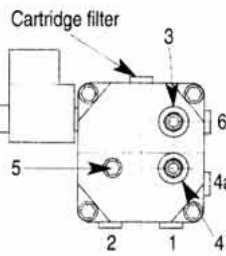
1. A manual isolating valve installed as close to the tank as possible.

2. A fire valve in accordance with BS5410 as shown in Fig. 10. The fire valve should be fitted externally with a fire detection element located within the appliance case. Use of a capillary type valve will allow a neat and simple installation. A suitable valve is the KBB manufactured by Teddington Controls Limited. A spring clip has been provided behind the electrical panel on CF/LLD models, shown in Fig. 2, and on the burner box on RS models, shown in Fig. 3, to allow a fire valve element to be mounted. Alternatively a fusible link or electrical system may be used. Under no circumstances should a combination isolating/fire valve be used as the sole fire protection device.

3. An oil filter should be fitted close to the oil storage tank. If there is doubt about the internal oil line condition, a further filter should be fitted near the boiler.

Fig. 9. Oil Pump.

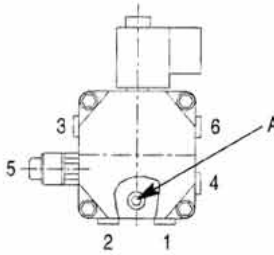
A. Danfoss BFP 41.



- 1 INLET
- 2 RETURN
- 3 BLEED AND PRESSURE GAUGE PORT
- 4 VACUUM GAUGE PORT
- 5 PRESSURE ADJUSTMENT
- 6 NOZZLE OUTLET

To convert to a double pipe system, remove plug 4a and insert the grub screw provided into the threaded hole. Connect flow and return pipes to (1) and (2).

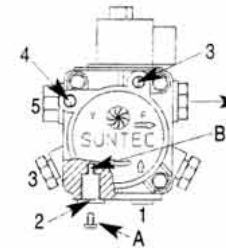
B. Danfoss BFP 11 Oil Pump.



To convert to a double pipe system: Remove the pump front cover, remove the changeover screw (A) nearest to ports 1 and 2, and the horseshoe washer underneath. Replace the changeover screw back into the threaded hole. Connect the flow and return pipes to 1 and 2.

Note: When removing the pump front cover ensure that a suitable receptacle is placed below the pump to catch the oil residue.

C. Suntec AS47C Oil Pump.



To convert to a double pipe system, remove the return port plug (2) and insert the grub screw (A) provided into the threaded hole (B). Connect flow and return pipes to (1) and (2).

TABLE 12 Single Pipe Gravity Feed System

HEAD (metres)	MAXIMUM ALLOWABLE PIPE RUN (metres)	
	8 mm inside dia. pipe (10 mm O.D. copper)	10 mm inside dia. pipe (12 mm O.D. copper)
0.5	12	30
1.0	25	69
1.5	37	91
2.0	49	100
2.5	62	100
3.0	74	100
3.4	87	100
4.0	99	100

TABLE 13 Double Pipe Sub-Gravity Feed System

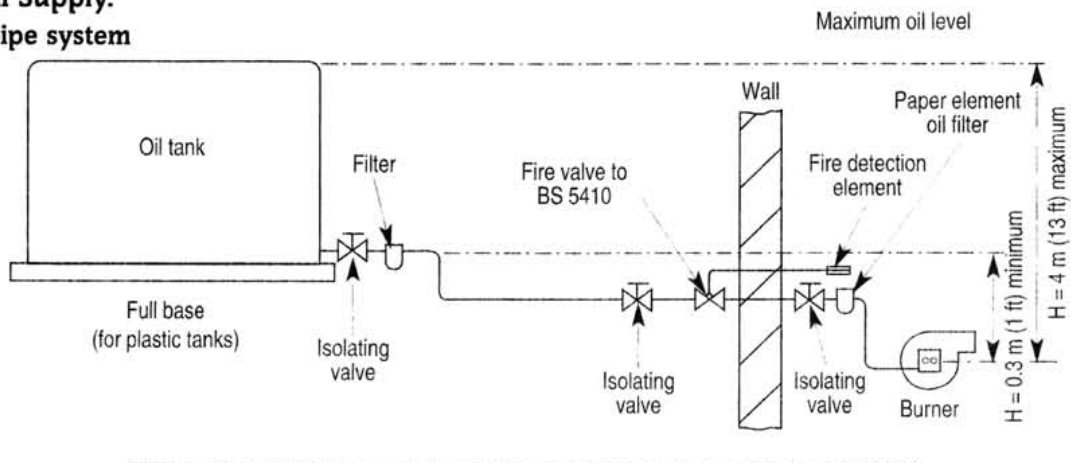
HEAD (metres)	MAXIMUM ALLOWABLE PIPE RUN (metres)	
	8 mm inside dia. pipe (10 mm O.D. copper)	10 mm inside dia. pipe (12 mm O.D. copper)
0	50	100
0.5	44	100
1.0	38	95
1.5	32	80
2.0	26	66
2.5	20	50
3.0	14	37
3.5	8	22

TABLE 14 Single Pipe Suction Lift with De-aerator

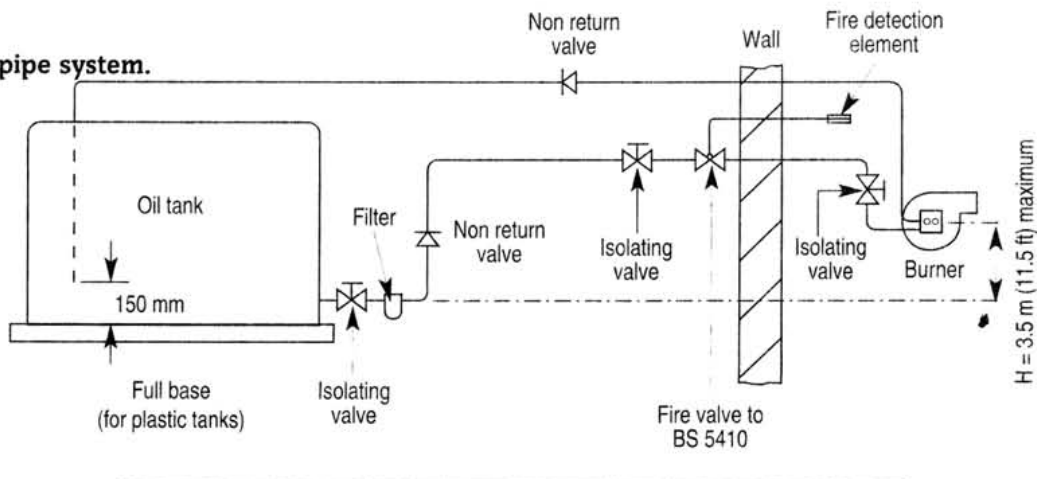
Fuel Flowrate	MAXIMUM ALLOWABLE PIPE RUN FROM TANK TO DE-AERATOR (metres)			
	2.5 (kg/h)	5.0 (kg/h)	10.0 (kg/h)	10.0 (kg/h)
HEAD (metres)	6 mm inside dia. pipe (8 mm O.D. copper)			8 mm inside dia. pipe (10 mm O.D. copper)
0	100	55	26	100
0.5	95	45	23	100
1.0	80	40	20	90
1.5	70	35	17	75
2.0	60	30	14	65
2.5	45	25	11	50
3.0	35	15	8	35
3.5	25	10	5	20

Fig. 10. Oil Supply.

(a) Single pipe system



(b) Double pipe system.



(c) Single pipe lift system with de-aerator.

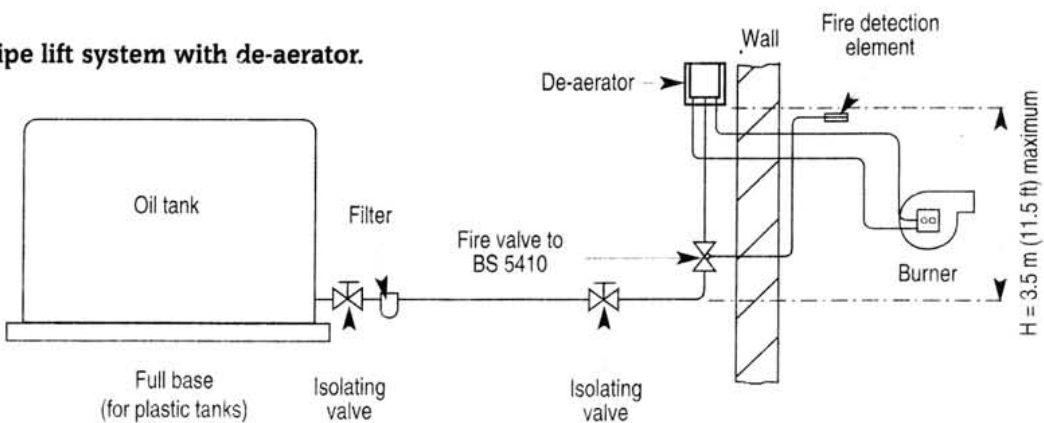
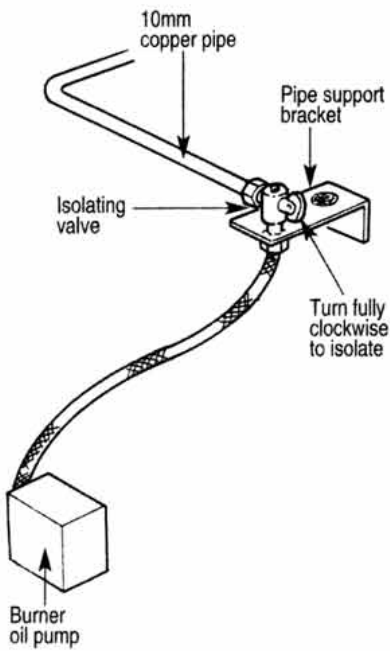
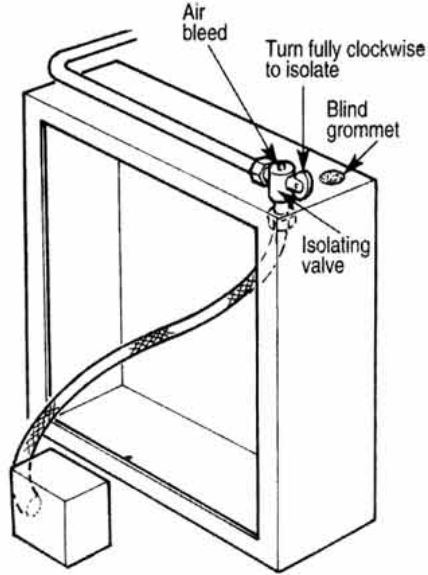


Fig. 11. Oil Pipe Installation.

(a) CF Bracket.



(b) Single Pipe System.



(c) Double Pipe System or Single Pipe Suction Lift with De-aerator.

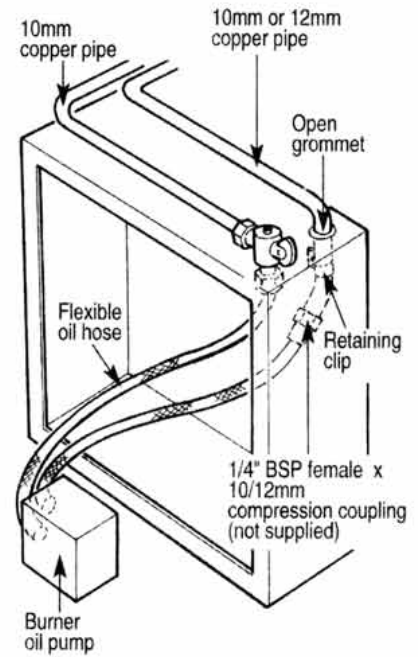


Fig. 12. Typical Open Vent Fully Pumped System (Honeywell 'Y' plan).

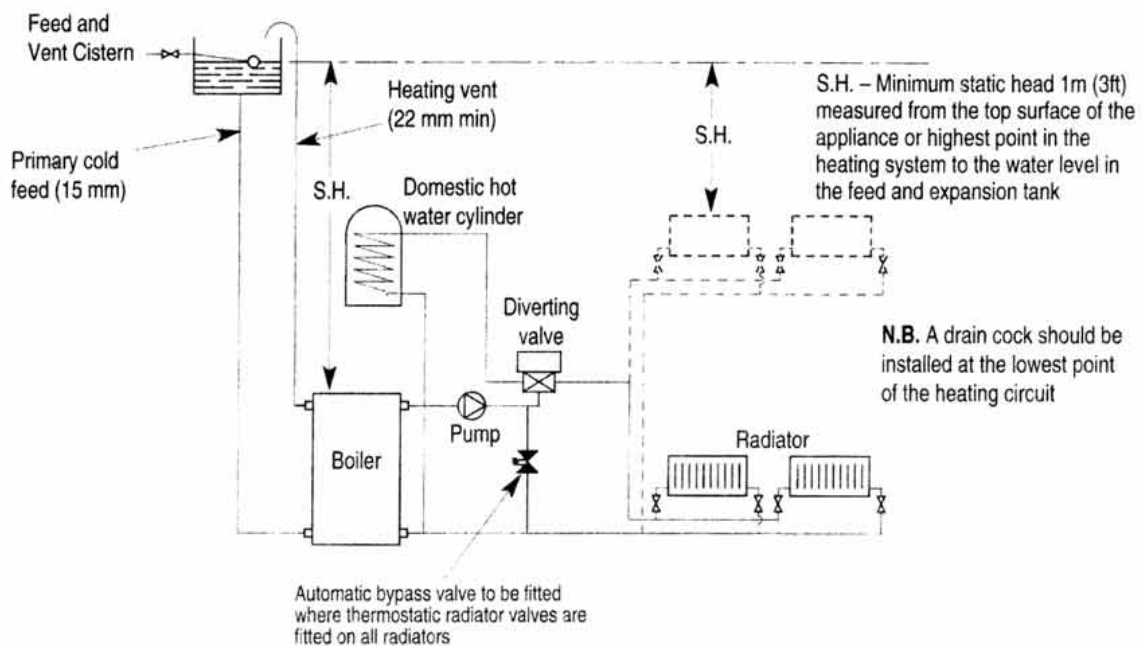


Fig. 13. Typical fully pumped sealed system (Honeywell 'Y' plan).

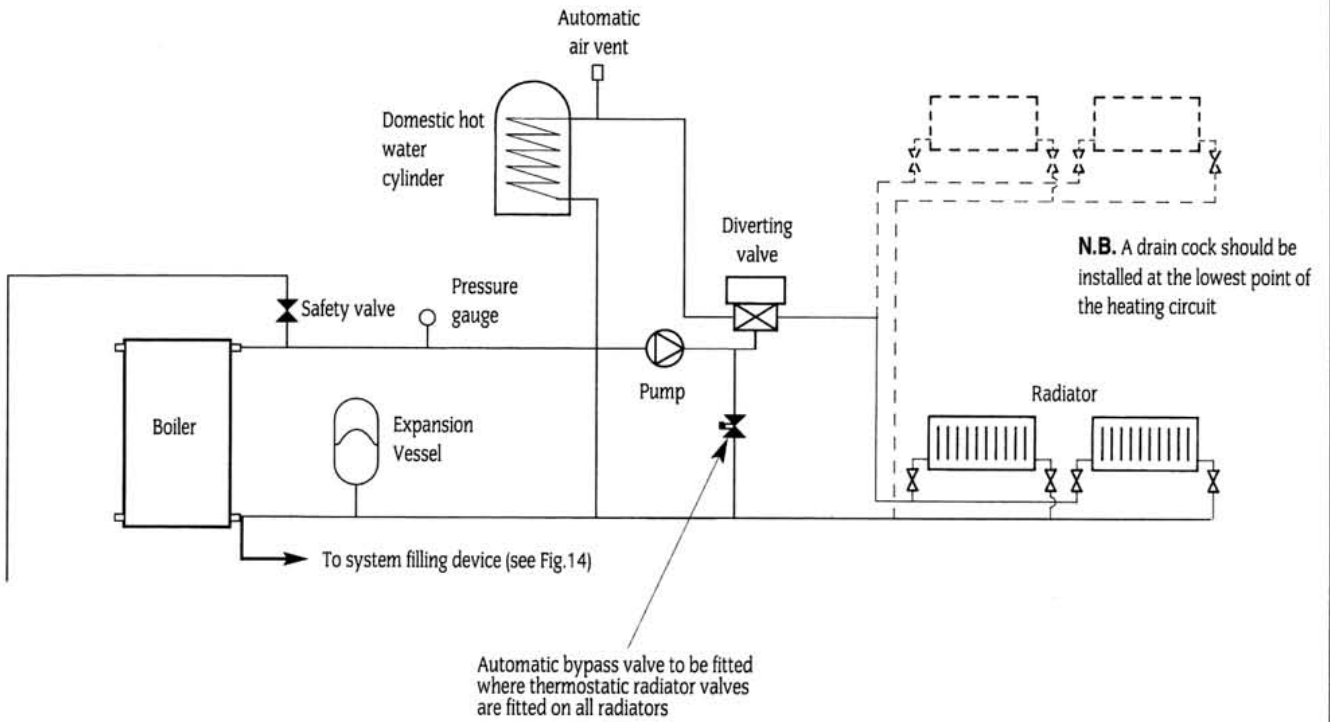
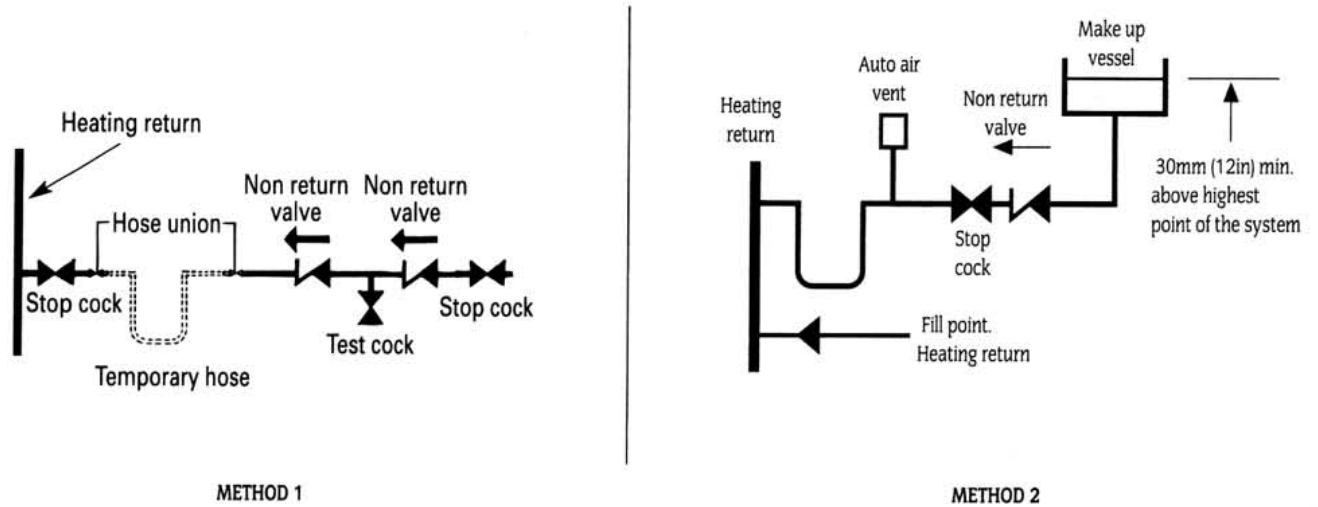


Fig. 14. System filling and make-up



9. Heating and Hot Water System

The heating and hot water system must be provided in accordance with the current Building Regulations.

9.1 The appliance is suitable for connection to all conventional indirect hot water systems utilising an indirect double feed cylinder.

9.2 The flow and return sockets are located at the rear of the appliance, two at high level (flow) and two at low level (return). Connection of the flow and return sockets can either be made on diagonally opposite sockets or on the same side of the boiler.

9.3 Provision has been made for locating the circulating pump within the appliance cabinet. If required, the socket located in the top front of the boiler should be used and the flow pipe run either side of the boiler (See Figs. 2 and 3).

9.4 On new installations it is recommended a room thermostat or programmable room thermostat is used in the main zone and thermostatic radiator valves are used in further heating zones.

On existing systems where a room thermostat is already fitted it is recommended to fit thermostatic radiator valves at least in the sleeping zones.

A automatic system bypass should be fitted on heating systems when all of the radiators are fitted with thermostatic radiator valves.

9.5 The pressure jet burner fitted to the appliance has full automatic control and hence there is no requirement for heat leak radiators.

9.6 Any unused boiler tappings should be plugged prior to filling. It should be noted that the flow tapping on the front of the boiler requires plugging when not used.

9.7 The primary system should be flushed and treated in accordance with the recommendations of BS 7593 before the system is handed over to the user.

9.8 The pump should be set in accordance with the heating load requirements to give a flow and return differential temperature of 11°C under full load conditions.

Open Vent Primary System.

(See Fig.12).

The following points are for guidance only. The system installation should be carried out in accordance with BS 5449: Part 1.

1. System Pipework

The first metre of pipework from all appliance connections must be in copper; afterwards copper or plastic pipe can be used. The plastic pipe must be manufactured to BS 7291 and installed to BS 5955 part 8. It is important to protect the system components; the plastic pipe specified must be resistant to the ingress of oxygen.

2. Feed and Expansion System

The feed and expansion pipes must rise continuously from the appliance and must be of the minimum diameter shown in Fig 12. The cistern must be arranged to provide a minimum static head of 1 metre above the top of the highest point in the heating circuit.

3. Filling and Venting

Air in the appliance is expelled through the vent pipe or dissipated into the system. Manual air vents should be fitted at any high points in the system.

Sealed Primary System

(See Fig. 13 and 14)

The appliance is supplied with a manual reset thermostat and is suitable for use with a sealed primary system.

1. System Pipework

Copper pipework must be used when installing the appliance on a sealed system.

2. General

The system should be installed in compliance with the requirements of BS5449: Part 1. The boiler must be fitted with a spring loaded safety valve set to operate at 3 bar (45 psi) and the pipe connections made throughout the system must be capable of sustaining a pressure of up to 3 bar.

The following is a list of major items which must be fitted to the system:

1. Safety valve – 3 bar
2. Pressure gauge – 0 to 4 bar.
3. Expansion vessel
4. Automatic air vent.

10. Electrical

(See Figs. 15 to 20).

10.1 The wiring between the appliance and the electrical supply shall comply with current IEE wiring regulations (and any local regulations which apply) for fixed wiring to a stationary appliance.

NOTE: It must be possible to completely isolate the appliance.

10.2 To gain access to the electrical terminal strip.

1. Isolate the mains electrical supply.
2. Remove the cabinet top panel by snatching squarely upwards.
3. Release the four screws securing the cover of the electrical control box and remove.

10.3 Mains Wiring

Mains supply – 230V AC ~ 50 Hz 5A External Fuse to BS1362.

LIVE - Brown, NEUTRAL - Blue, EARTH - Green/Yellow

Mains Cable: 0.75mm² (24 x 0.20 mm) to BS 6500 Table 16.

The boiler and system controls must be supplied using a single fused supply.

The mains supply cable should be connected into the terminals marked **L** (Live), **N** (Neutral) and **E** (Earth) on the appliance terminal strip and securely held in the cable clamp located in the left-hand side of the electrical tray base. To secure the cable, remove the clamp retaining screw and pull its inner body out to allow the cable to be fed through. With the cable in position refit the screw and fully tighten to grip the cable. Feed the cable between the side panel and the boiler insulation jacket and route to the connection point avoiding any hot surfaces.

The appliance must be earthed.

10.4 Programmer

(See Fig. 16).

A plug in, colour co-ordinated, 2 channel electronic programmer is available from Worcester, Bosch Group. Full instructions covering installation and operation of the programmer are included with the kit. (See Fig. 16a)

The programmer will give fully independent central heating (CH) and hot water (HW) programmes when the switch on the rear of the unit is set to P.

If an external programmer is to be fitted to the boiler the link plug should be removed from the programmer terminal strip. (See Fig. 16b). The LIVE, NEUTRAL and EARTH wires should be connected to the LIVE, NEUTRAL and EARTH terminals on the main terminal strip and the switched lines connected to terminals 1 and 2.

NOTE: The mains supply cable should not be connected to an external time switch when a frost thermostat or low-level discharge post purge unit is fitted to the Danesmoor standard wiring block.

NOTE: Under no circumstances should the timer be connected to a separate electrical supply. Safety is assured from a single fused supply to the boiler.

10.5 Safety Check

In the event of an electrical fault after the installation of the appliance, the electrical system shall be checked for short circuits, fuse failure or incorrect polarity of connections.

10.6 Pre-wired Remote "Y" or "S" Plan systems

(See Fig. 17).

If the system is fully pre-wired at a junction box remotely from the boiler it can be connected to the boiler. The diagram shows connection details of two proprietary systems (Honeywell and Invensys).

The Worcester fascia mounted programmer can be fitted instead of an external timer to the remote junction box. Remove the link plug (8 to 9) and connect the programmer plug into the time clock connector. Connect terminal 1 from the boiler terminal block to the 'HOT WATER ON' on the remote 10 way junction

box. Connect terminal 2 from the boiler terminal block to the 'HEATING ON' on the remote 10 way junction box..

NOTE: A "Y" Plan requires a live feed from 'HOT WATER OFF' switch position. In order to achieve this, using a Worcester programmer, remove the orange wire from terminal 9 and pull back through the tie wraps. Ensure the brown wire is firmly secured in terminal 9. Connect the orange wire to terminal 6 and connect terminal 6 on the boiler terminal block to the 'HOT WATER OFF' connection at the remote 10 way junction box.

10.8 Honeywell "S" Plan

(See Fig. 18).

The "S" plan provides complete control on installations having pumped circulation to both the domestic hot water and radiator circuits.

The domestic hot water and radiator circuits are independently controlled by two motorised valves via a cylinder thermostat and a room thermostat. Both thermostats switch the water circulator and the boiler on and off.

10.9 Honeywell "Y" Plan

(See Fig. 19).

The "Y" Plan provides complete control on installations having pumped circulation to both the domestic hot water cylinder and radiator circuits.

The domestic hot water and radiator circuits are controlled by a 3 port motorised valve via a cylinder thermostat and a room thermostat. Water flow is diverted to either circuit or to both circuits at the same time. Both thermostats switch the water circulator and the boiler on and off.

Note: The "Y" plan requires a live feed from the hot water "off" switch position. In order to achieve this, using a Worcester programmer, remove the orange wire from terminal 9 and pull back through the tie wraps. Do not attempt to cut the tie wraps. Ensure that the brown wire is firmly secured in terminal 9. Connect the orange wire to terminal 6.

10.10 Frost Protection

(See Fig. 20).

For full frost protection a single pole double switch thermostat should be fitted so that both the boiler and the circulating pump circuits are energised under frost conditions. Frost protection will be lost if there is no power supply to the boiler.

Fig. 15. Wiring Diagram (Standard).

Mains supply 230V 50Hz

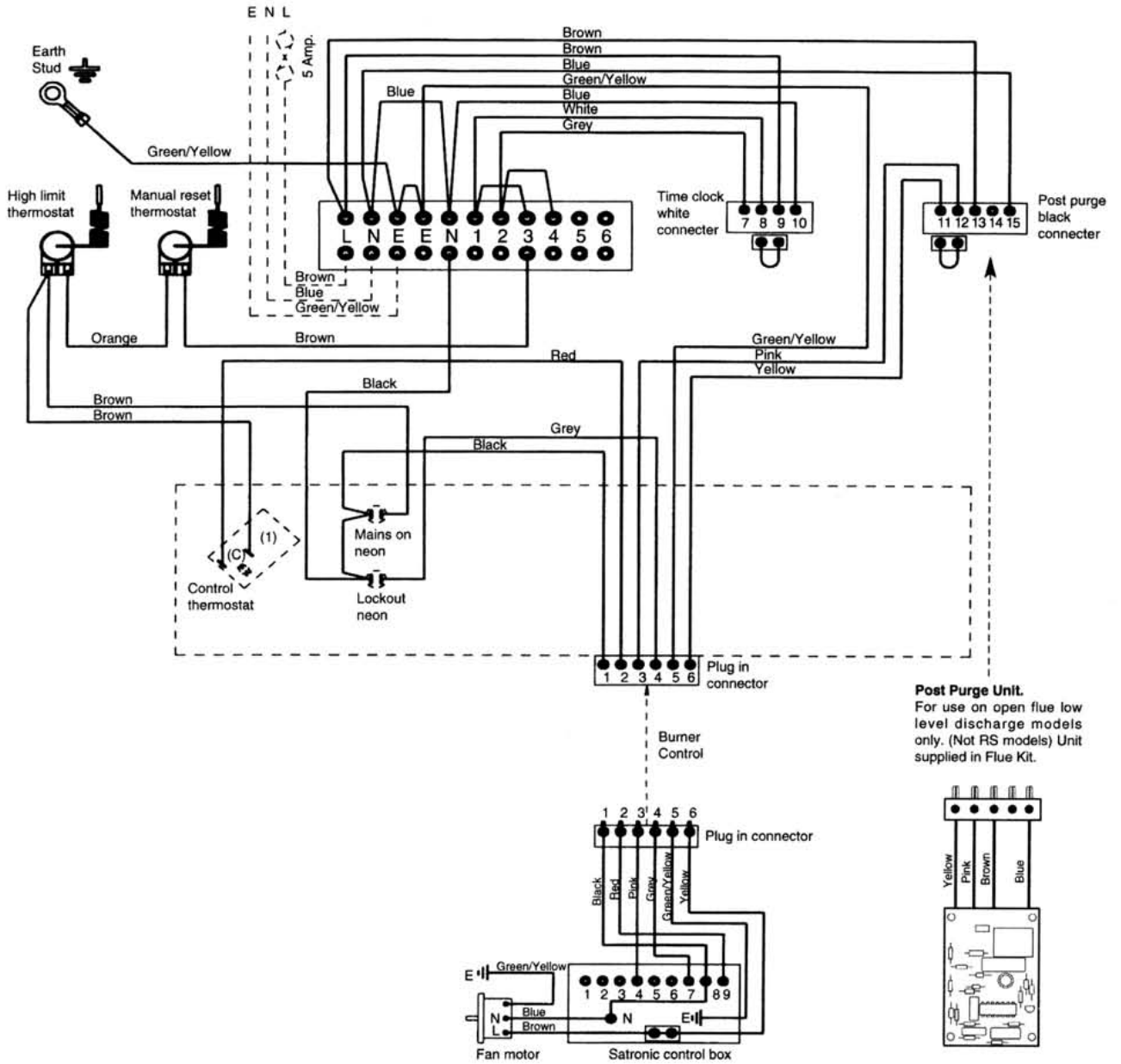
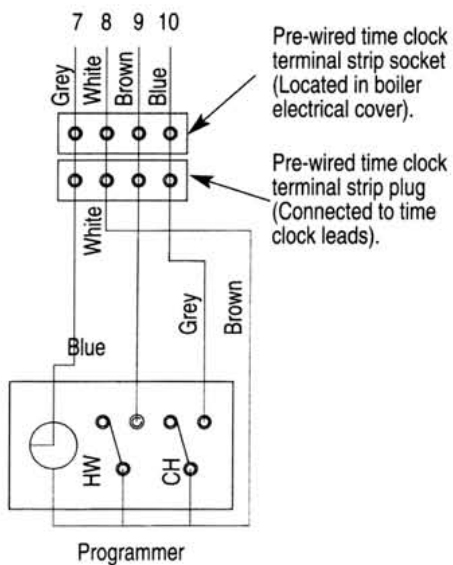


Fig. 16. Programmer Connections

(a) Internal Programmer



(b) External Programmer

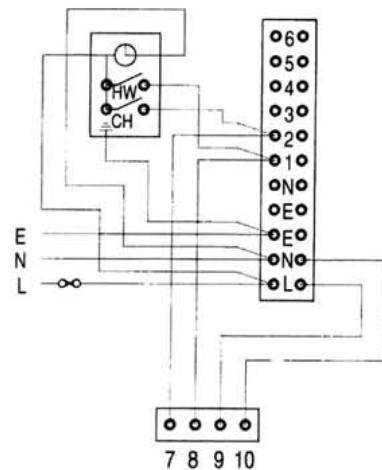


Fig. 17. Pre-wired Remote 'Y' Plan or 'S' Plan.

NOTE: When using a Worcester programmer set the switch on the rear of the programmer to 'P'.
Remove link 1 to 3

NOTE: If a frost thermostat is required it can be wired to the remote junction box.

NOTE: The 10 way junction box must be a terminal block type and current rated to at least 5 amps.

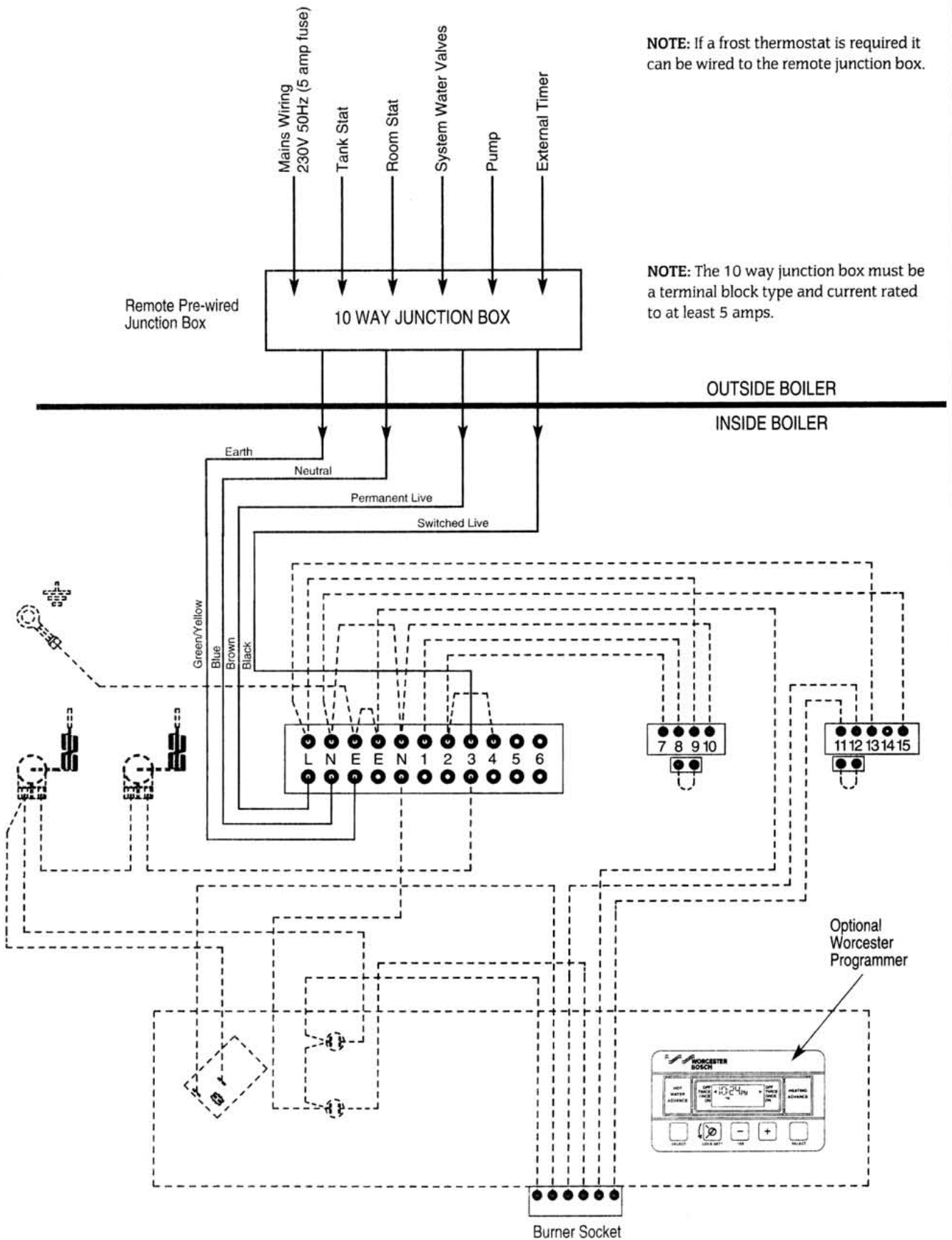


Fig. 18. Honeywell 'S' Plan.

NOTE: When using a Worcester programmer set the switch on the rear of the programmer to 'P'.
Remove link 1 to 3 and link 2 to 4 and make link 3 to 4

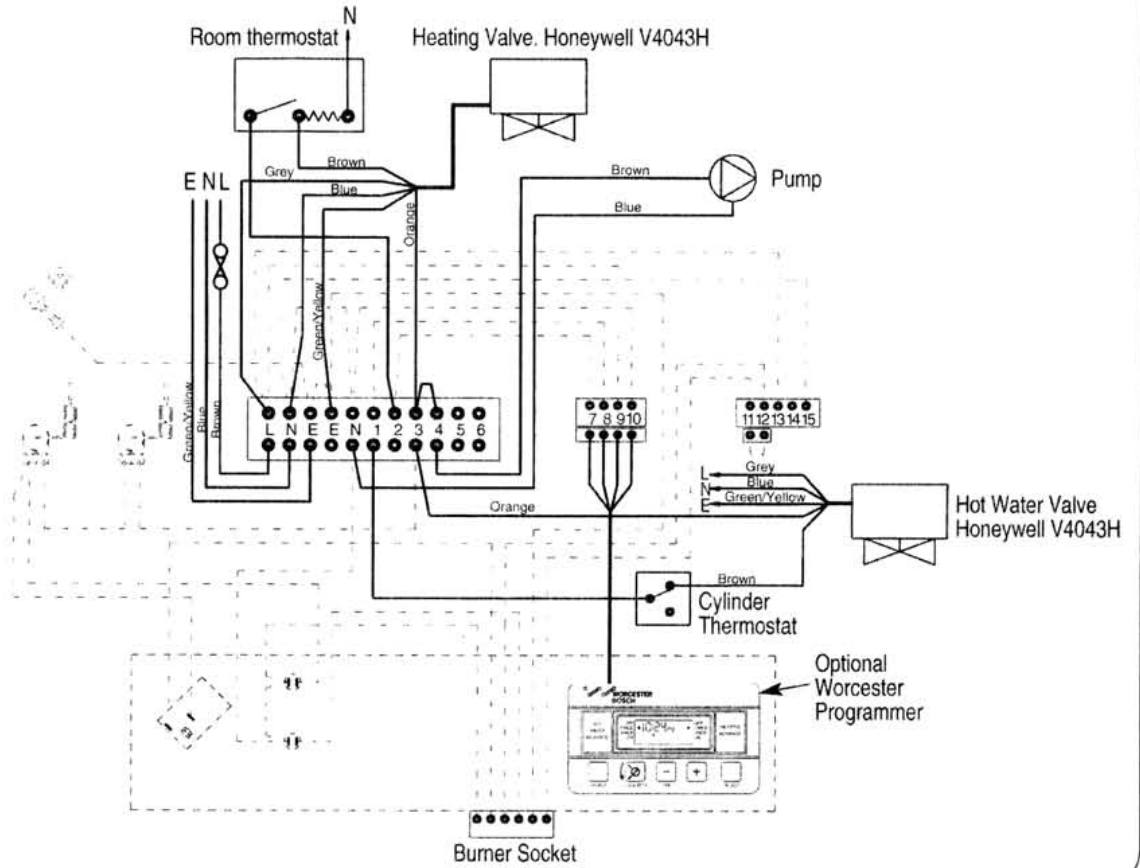


Fig. 19. Honeywell 'Y' Plan.

NOTE: When using a Worcester programmer remove the orange wire from terminal 9 and connect to terminal 6. Set the switch on the rear of the programmer to 'P'. Remove link 1 to 3 and link 2 to 4 and make link 3 to 5.

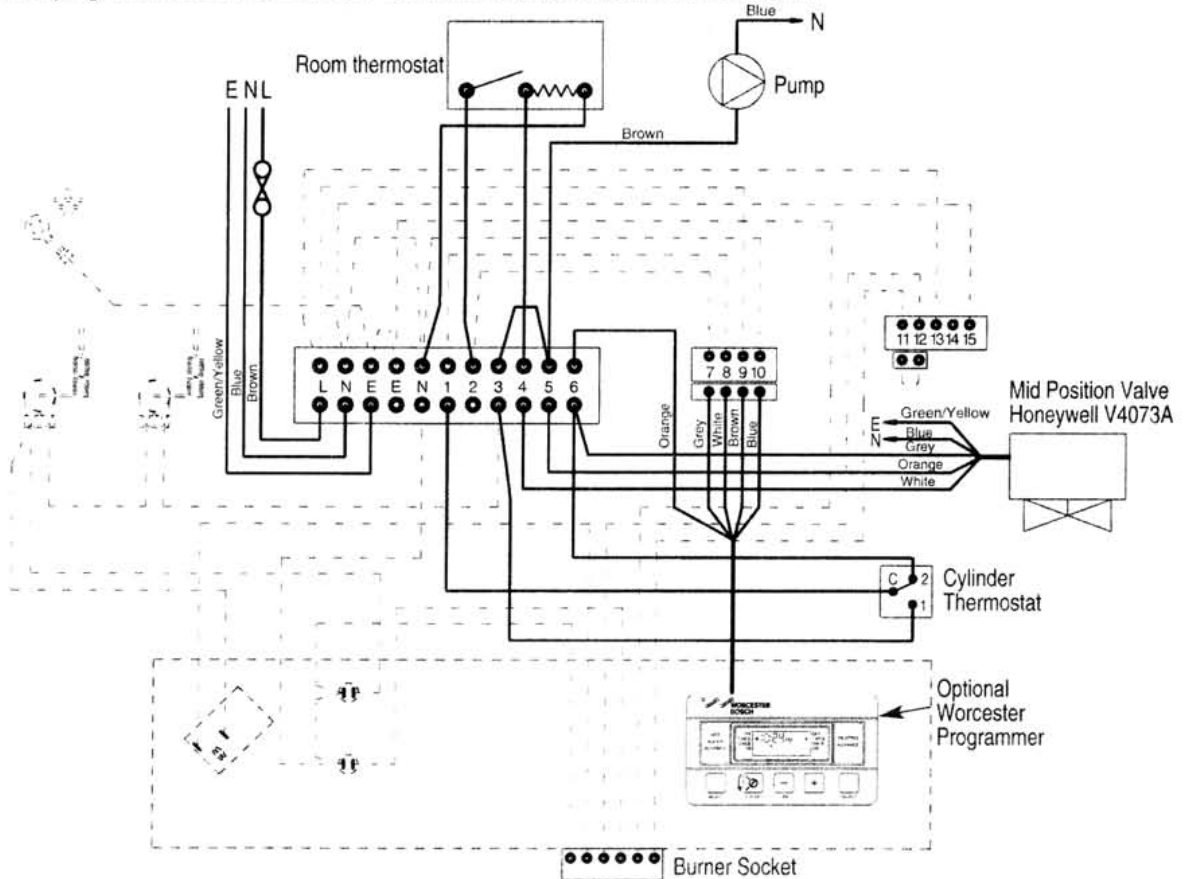
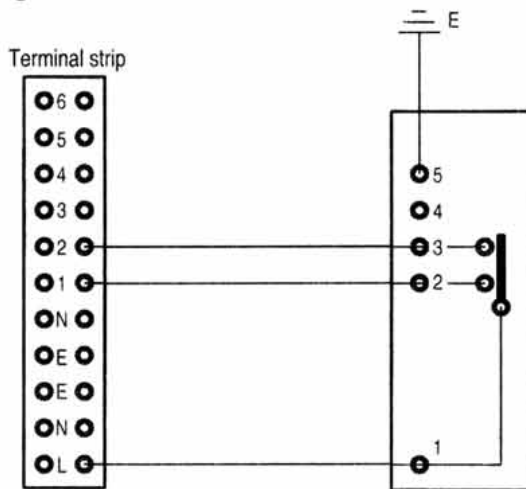


Fig. 20. Frost Protection.



11. Installation

11.1 After unpackaging the appliance it is recommended that all cabinet panels are removed, as described in Section 5, and stored in a safe place to avoid damage during installation and allow easy inspection for any leaks after the system has been filled.

11.2 Remove the burner as described below and store in a safe place until the appliance is ready for commissioning.

(a) Conventional Flue Appliance (CF/LLD).

1. Remove the electrical lead plug by depressing the two locking ears and pulling the plug downwards.

2. Remove the burner from the boiler by slackening the two M6 retaining screws located in the burner housing ring and pulling the burner clear. This will require the use of a 5mm allen key.

(b) Room Sealed Balance Flue Appliance (RS).

1. Remove the burner box cover by pulling forwards to release the ball studs. This will be found easier by pulling on the side of the handle first to release two of the ball studs and then repeating on the other side. Take care not to pivot the remaining two ball studs too far around as this will cause damage to the spring clips.

2. Remove the electrical lead plug by depressing the two locking ears and pulling the plug.

3. Push the electrical lead grommet back through the burner surround box and feed the lead through the hole.

4. Remove the burner from the boiler by slackening the two M6 retaining screws located in the burner housing ring and pulling the burner clear. This will require the use of a 5mm allen key.

11.3 Flue system installation.

Install the appliance flue system as described in Section 7.

11.4 Heating system installation.

Benchmark Before the appliance is fitted to the heating system flush the system and mains water supply.

1. Plumb the boiler into the central heating system.

2. Check that all unused sockets have been plugged.

3. Fill the system and vent all radiators and high points to remove air from the system.

4. Check the boiler and all pipework connections for leaks.

11.5 Oil supply installation.

(See Figs. 9 to 11).

NOTE: Never route the oil supply pipe/hose directly below the combustion chamber base.

NOTE: Connection of rigid copper pipe to the oil pump is not recommended. Connection to the oil pump should be made with flexible oil hoses as shown in Fig. 11.

(a) Single pipe suction lift with de-aerator.

For connection of single pipe suction lift with de-aerator follow

the procedure as for a double pipe system as described below.

(b) Double pipe system oil return pipe.

When fitting an RS balanced flue appliance follow steps 1 to 11. When fitting a CF/LLD appliance follow step 1 and fit a bulkhead fitting to the bracket for the return pipe and continue from step 10.

1. Remove the isolating valve bulkhead fitting by unscrewing the locknut on the underside.

2. Remove the blind grommet from the fixed burner surround box and discard.

3. Replace the blind grommet with the open grommet supplied in the plastic bag.

4. Slacken the pipe retaining clip screw located directly below the grommet hole. When using 12mm copper pipe replace the clip with the larger one supplied.

5. Bend a piece of 10mm or 12mm copper tube (as selected) to the correct profile to allow the pipe to be fed down the side of the appliance. Make a slight chamfer on the end of the pipe to be fed through the grommet to facilitate easy insertion.

6. Lubricate the grommet hole with vaseline (or butter etc.) and slide the pipe through the hole, supporting the grommet on its underside to prevent it dislodging.

7. Feed the pipe through the retaining clip, allowing approximately 80 mm of pipe to project beyond the clip, and tighten the retaining screw. Take care not to overtighten the screw!

8. Hold the pipe at the retaining clip and gently pull the pipe forward sufficiently to allow a compression to 1/4 inch BSP female fitting to be fitted for connection to the oil return flexible hose.

9. Connect the fitting to the pipe and fit a 1/4 inch BSP taper thread flexible hose, ensuring a good seal using PTFE tape or suitable oil sealing compound. The flexible hose should have a 1/4 inch BSP rotating union taper fitting at the other end with a 90 degree bend and 1/4 inch BSP nipple for connection to the oil pump.

10. Replace the isolating valve bulkhead fitting.

11. Fit the oil supply pipe as described in the following section.

(b) Single pipe system oil supply pipe.

1. Bend a piece of 10mm or 12mm copper tube (as selected) to the correct profile to allow the pipe to be fed down the side of the appliance. The pipe may be routed along either the right or left hand side of the boiler as required. When using 12mm pipe fit a 12mm to 10mm compression coupling and connect to the valve with a short piece of 10 mm pipe, otherwise connect direct to the valve.

NOTE: never use soldered joints on oil supply pipes as this could cause a hazard in the case of a fire.

2. Route the pipe back to the oil supply tank ensuring that it is hard against the boiler, to allow installation of the side panel.

3. With the isolating valve in the correct orientation tighten the back-nut.

4. Turn the isolating cock fully clockwise to close the valve.

5. Open the main oil supply valve at the tank and check for any leaks.

6. Place a suitable container below the bulkhead fitting and open the valve.

7. Draw off at least 2.5 litres of oil until a steady flow of clear uncontaminated oil can be seen and turn off the isolating valve.

NOTE: This method may not be possible on some installations where a sub-gravity system is used. Where this problem arises bleed the system using the oil pump as described in Section 12 and remove and clean the oil pump filter to remove any debris collected as a result of installation.

11.6 Replace the electrical control panel and side panels in reverse order to the removal procedure of Section 5 and connect the electrical supply as described in Section 10.

12. Commissioning the Appliance

Ensure that no foreign matter is left in the system as this could cause damage to the appliance.



Benchmark Water Treatment: For optimum performance after installation, this boiler and its associated central heating system should be flushed in accordance with the guidelines given in BS7593:1992 - Treatment of water in domestic hot water systems. Full instructions are supplied with proprietary cleansers sold for this purpose. If an inhibitor is to be used after flushing, it should be used in accordance with the inhibitor manufacturers instructions.

Suitable flushing agents and inhibitors are available from Betz Dearborn Tel: 0151 4209595 and Fernox Tel: 01799 550811. Instructions for use are supplied with these products.

IMPORTANT: Any system cleanser must be flushed from the system before an inhibitor is added.

12.1 Check that the electrical supply to the appliance is switched off.

12.2 When commissioning the appliance after initial installation follow the procedure from 12.3, otherwise remove the burner first as described in Section 14.3.

12.3 Prepare the heating system

1. After initial installation and checking for leaks, as previously described, drain down the system sufficiently to add a flushing agent. After flushing drain the system before re-filling

2. Refill the system.

12.4 Check the Burner

1. Check that the nozzle and electrode settings are correct for the relevant burner. (See Figs. 21, 22, 23, 24, 25 and 26).

2. Check that the nozzle lies central with the combustion head hole.

3. Check for any visible defects.

12.5 Replace the burner

1. Connect the flexible oil supply hose to the isolating valve bulkhead fitting and tighten sufficiently to form a good seal. Where a double pipe or single pipe suction lift with de-aerator system is being used refer to Fig. 9, and connect the oil return flexible hose to the return pipe fitting.

2. With the sponge O-ring gasket around the burner blast tube insert the burner into the housing tube. Push the burner firmly forward to compress the gasket and tighten the two locking screws using a 5mm Allen key.

Note: It is important that a good seal is made between the burner and the boiler to prevent re-circulation of the flue gases from the combustion chamber to the burner inlet, or the room in the case of a CF/LLD appliance.

3. On the RS balanced flue model, feed the electrical lead back through the hole in the burner surround housing and fit the grommet into the hole ensuring a seal is made.

4. Re-connect the electrical lead plug into the control box.

12.6 Check the installation

1. Check that the appliance is correctly wired as described in Section 10.

2. Check the combustion chamber base insulation is positioned correctly in the bottom of the boiler.

3. Check that all baffles are correctly located and the heatshield is correctly mounted (20/25, 26/32, 32/50 and 50/70 models) as shown in Fig. 27.

4. Check that the baffle retainer is correctly mounted (20/25 and 26/32, 32/50 and 50/70 models) as shown in Fig. 27c, 27d and 27e.

5. On the 50/70 remove and discard the transit baffle retainer.

6. Ensure that the cap is firmly seated in position and check the cap retainer is correctly mounted (32/50 and 50/70 only) as shown in Fig. 27d, 27e and 28.

7. On the 32/50 ensure the tabs on the top baffle are positioned at the front of the boiler.

8. Check that the control thermostat and auto reset high limit thermostat phials are correctly located in the boiler thermostat pocket positioned in the top front of the boiler.

9. Check that the manual reset limit thermostat is located in the steel pocket above the electrical box mounting bracket on the front face of the boiler.

10. Check that all of the air-ways to the burner are clear of any obstruction.

12.7 Fit a pressure gauge and manifold to the burner pump at the point indicated in Fig. 9, or the pressure gauge port shown in Fig. 23 on the 20/25.

12.8 Turn on the electricity to the appliance.

12.9 Bleed the burner

Single pipe system only

Release the fuel bleed port on the manifold and place a suitable receptacle beneath. Turn on the boiler thermostat and allow the burner to run through to lockout. Wait two minutes and reset the burner control box. Repeat the procedure at least three times or until a steady stream of oil, without air, is exhausted from the bleed port. Re-lock the bleed port.

Double pipe system

A double pipe system will automatically vent the air back to the oil tank. Turn on the boiler thermostat and allow the burner to run through to lockout. Wait two minutes and reset the burner control box. Repeat the procedure until the burner fires and runs in a steady state. This may take several attempts depending on the oil pipe length and height.

Single pipe suction lift system with de-aerator

A single pipe suction lift system with de-aerator will automatically vent air through the de-aerator by turning on the boiler thermostat and allowing the burner run to lockout. Wait two minutes and reset the burner control box. Repeat the procedure until the burner fires and runs in a steady state.

On long oil pipe runs from the oil tank to the boiler it is recommended that the de-aerator be primed to prevent damage to the oil pump.

To prime the the de-aerator follow the following procedure:

- Disconnect the flexible oil inlet hose end nearest the de-aerator and place in a container of oil.
- Place an empty container to collect oil from the oil inlet pipe connection from the de-aerator.
- Prime the de-aerator and reconnect the de-aerator to the flexible oil inlet hose.

12.10 Adjust the air shutter and pump pressure to the settings recommended in Tables 2 to 8. After a pre-ignition period of approximately 15 seconds the burner should ignite. Flame sensing is carried out by means of a photocell mounted in the burner body. Should the boiler fail to establish a normal firing pattern (or should flame failure occur during running), the absence of a flame is sensed and the control box is monitored to a safe lockout condition and the boiler is shut down. The lockout indicator light in the boiler control panel will illuminate indicating that the burner has gone to lockout. In this instance wait two minutes and press the lockout reset button mounted in the burner control box. Another start sequence is then initiated. Repeat the procedure until a flame is established.

Note: Persistent lockout when running indicates a fault and a Service Engineer should be consulted.

12.11 Run the boiler for approximately 3 minutes and switch off checking that there is no after-spurting from the nozzle. This can be detected by oil saturation on the blast tube. If after-spurting occurs remove the burner from the boiler, unscrew the nozzle, and while holding the burner in a vertical position, fill the nozzle holder with oil. Refit the burner and continue to run the boiler for three minute periods until after-spurting stops.

Note: In order that after-spurting is reduced to a minimum during the commissioning period it is recommended that a pressure gauge only is fitted on the external pressure gauge port on the Electro Oil B11 (See Fig. 23). Use of a "T" piece pressure gauge manifold will increase the oil line volume and hence increase the degree of after-spurting.

12.12 Run the boiler for a further 15 minute period and then finally fine tune the air shutter setting to give the CO₂ level specified in Tables 2 to 8 less 0.5% CO₂. During this period some smoke will be emitted due to the burning of the organic binder in the base insulation board. Smoke readings will therefore be inaccurate at this point.

Note: A flue gas sampling point is located on the boiler top plate.

12.13 Check that the smoke reading is in the range 0-1. If this cannot be achieved then check that the burner head is set correctly and the nozzle is in good condition.

12.14 Check that the flue temperature does not exceed the value specified in Tables 2 to 8. If this is the case then check that the baffles are correctly located. If the baffles are correctly located then reduce the pump pressure since nozzle variations of up to + or - 15% may occur.

12.15 Remove the oil pressure gauge and manifold and check all oil system joints for any signs of leakage.

12.16 On the RS balanced flue model fit the burner cover box supplied in the flue terminal kit by lining up the four ball studs and the polarising pin in the top flange of the box and firmly pushing forward. Check that the cover is properly seated by pressing forwards on the front top and then bottom face of the box to ensure a room seal is achieved.

On the CF/LLD model fit the cabinet front panel.

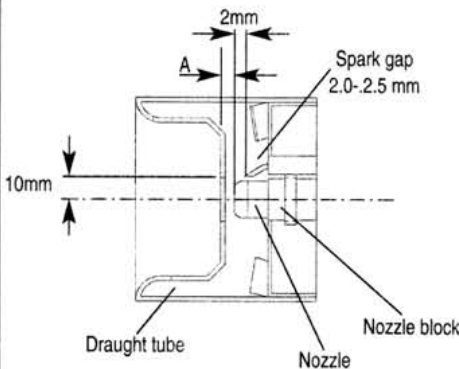
12.17 Allow the burner to run for a further five minutes and then recheck the CO₂ level and adjust the air setting if required. With the burner cover/panel fitted as 12.16, repeat the previous test procedure and check that the smoke number is in the range 0-1. Repeat the fine tuning procedure if found necessary.

12.18 Refit the cabinet top and front panels in the reverse order to that described in Section 5.

12.19 When the heating circuit has reached full operating temperature check the whole system for any leaks.

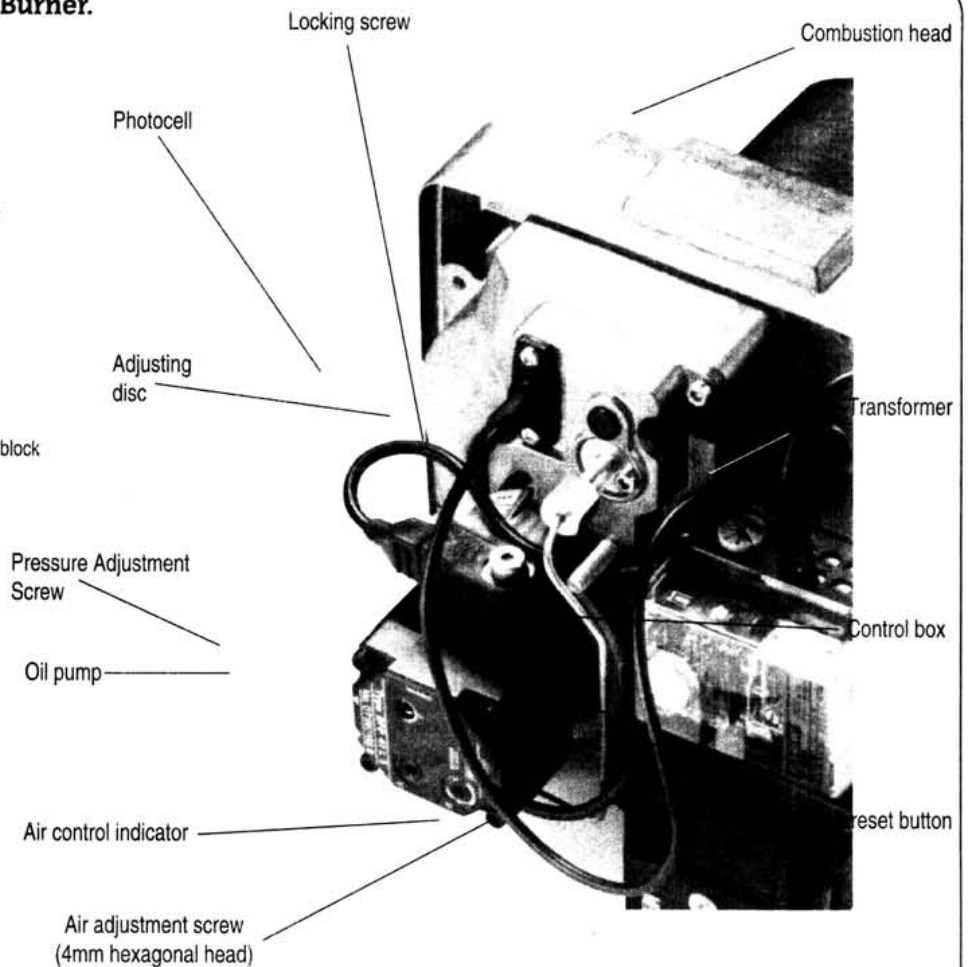
**Fig. 21. Electro Oil Inter B9A Burner.
(12/14 model)**

Combustion Head



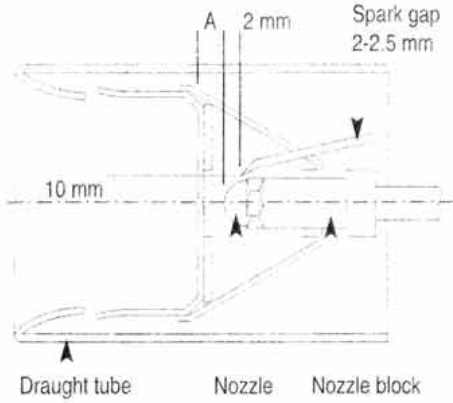
Output kW	Head Type	Dimension A
12	PL 6/7/21.5/10-E	3 mm
14	PL 6/7/21.5/10-E	5 mm

To adjust the nozzle position, undo the locking screw located at the rear of the nozzle line and rotate the adjusting disc one turn anti-clockwise to move forward by 1 mm.



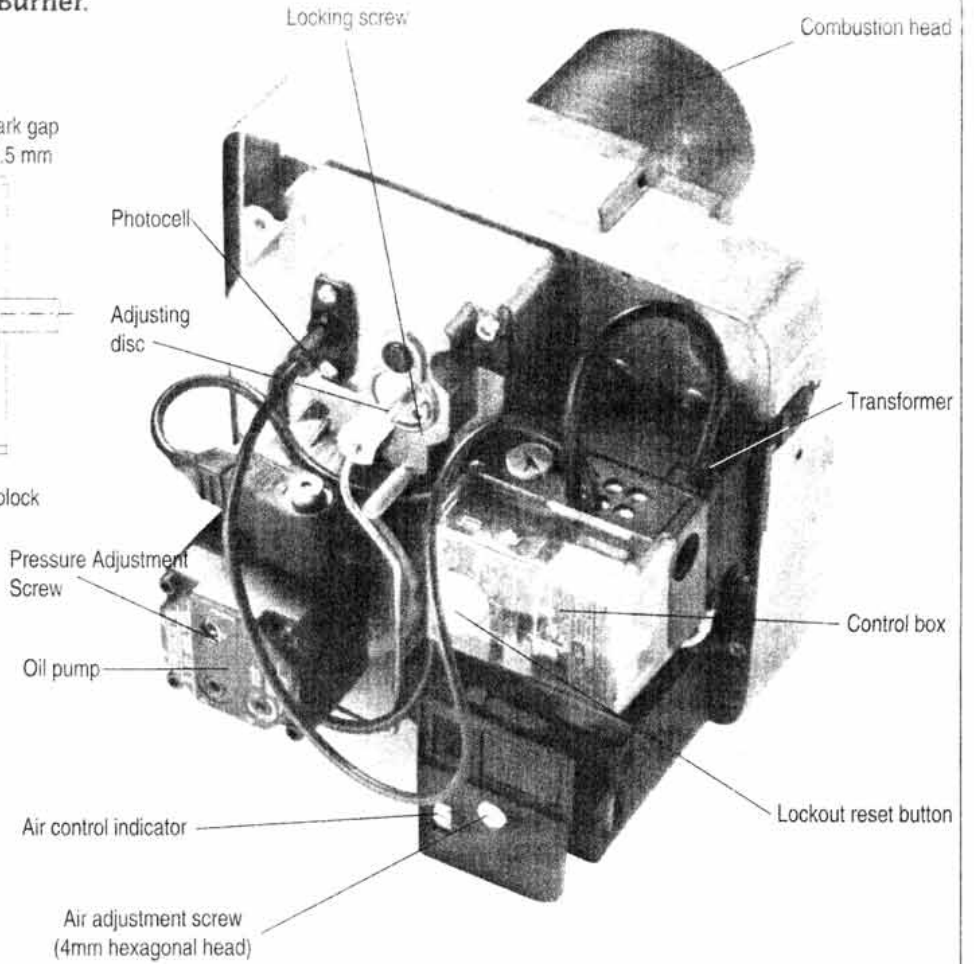
**Fig. 22. Electro Oil Inter B9B Burner.
(15/19 model)**

Combustion Head



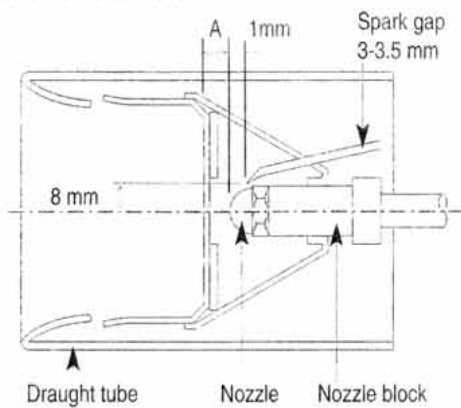
Output kW	Head Type	Dimension A
15	PL 6/7/21.5/10	3 mm
17	PL 6/7/21.5/10	5 mm
19	PL 6/7/21.5/10	5 mm

To adjust the nozzle position, undo the locking screw located at the rear of the nozzle line and rotate the adjusting disc one turn anti-clockwise to move forward by 1 mm.

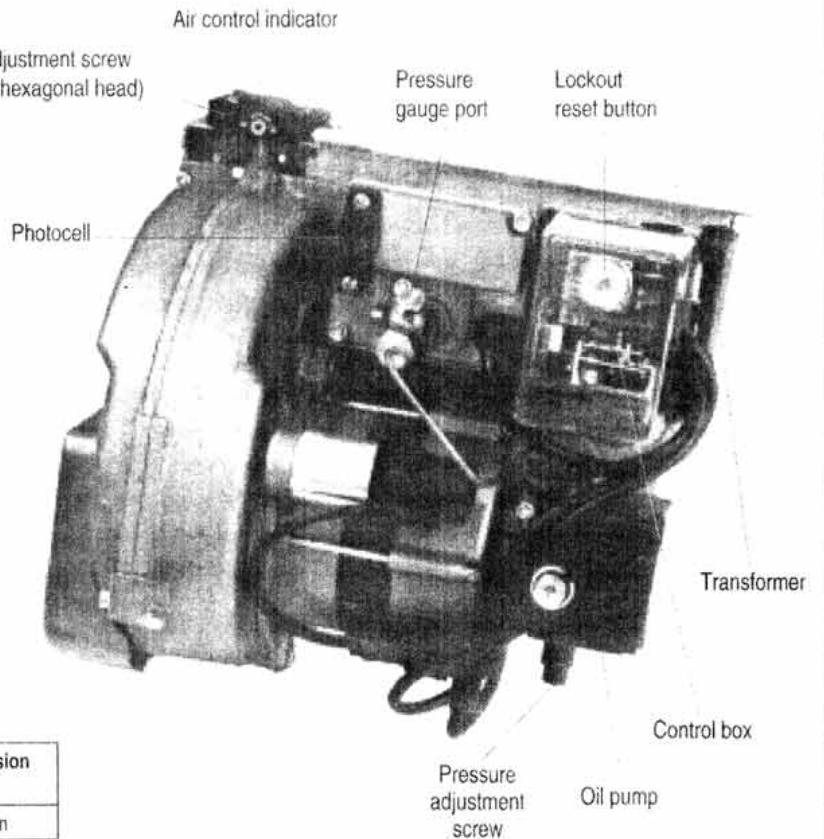


**Fig. 23. Electro Oil Inter B11 Burner.
(20/25 model).**

Combustion Head

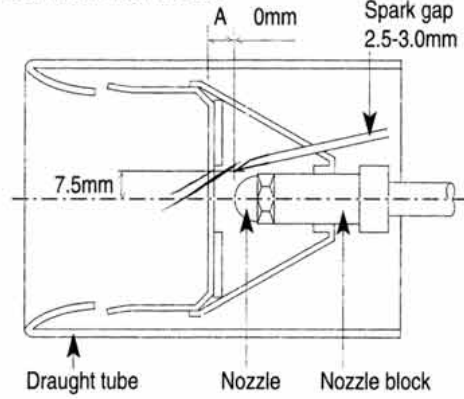


Output kW	Combustion Head	Dimension A
20/25	PL 10/4/24/10 x 78 mm	5 mm

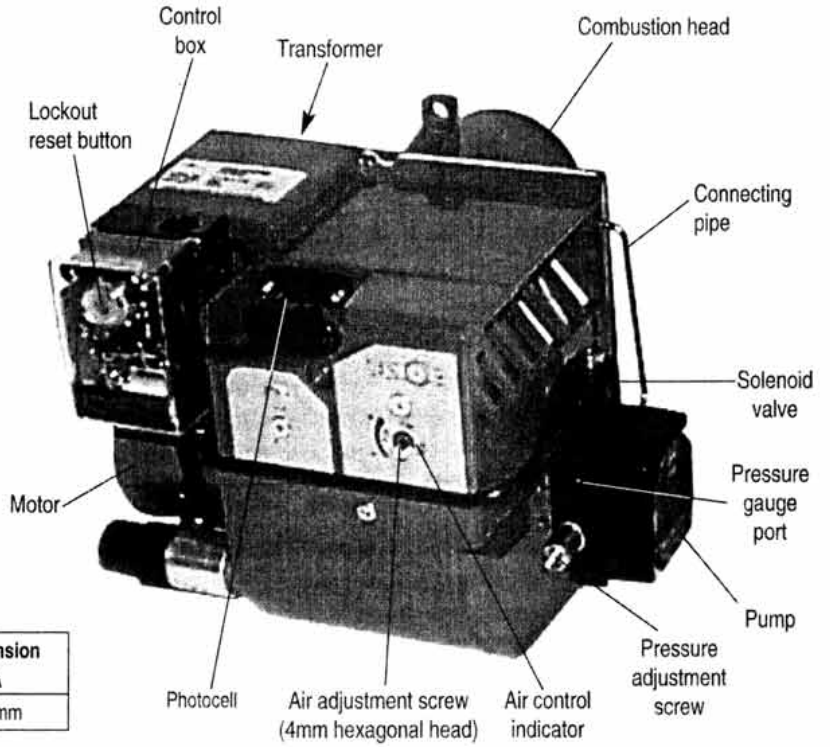


**Fig. 24. Electro Oil Sterling Burner.
(26/32 model).**

Combustion Head



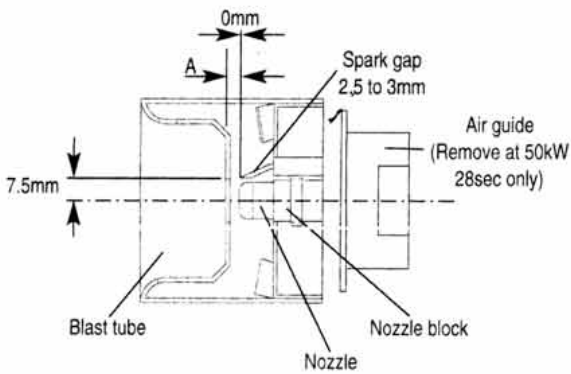
Output kW	Combustion Head	Dimension A
26-32	PL 6/7/21.5/10 x 78 mm	3.5mm



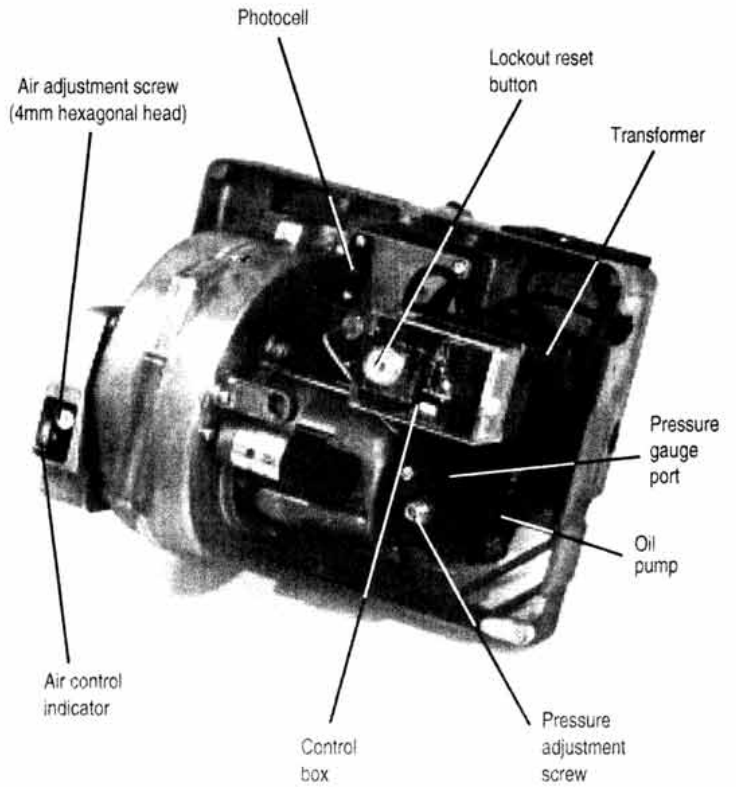
**Fig. 25. Electro Oil Inter B20C Burner
(32/50 model).**

Combustion Head

PL 10/8/10/6/19/10 - E x 78mm

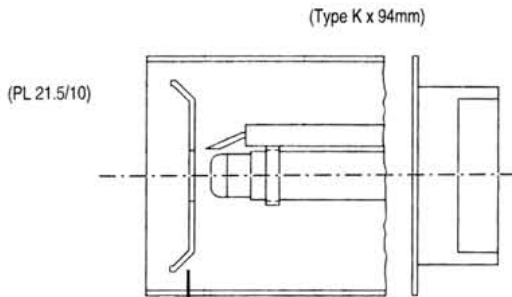


Output kW	Fuel	Dimension (mm) A
32	28sec. Kerosene	3
41	28sec. Kerosene	6
50	28sec. Kerosene	6
41	35sec. Gas Oil	6
50	35sec. Gas Oil	6

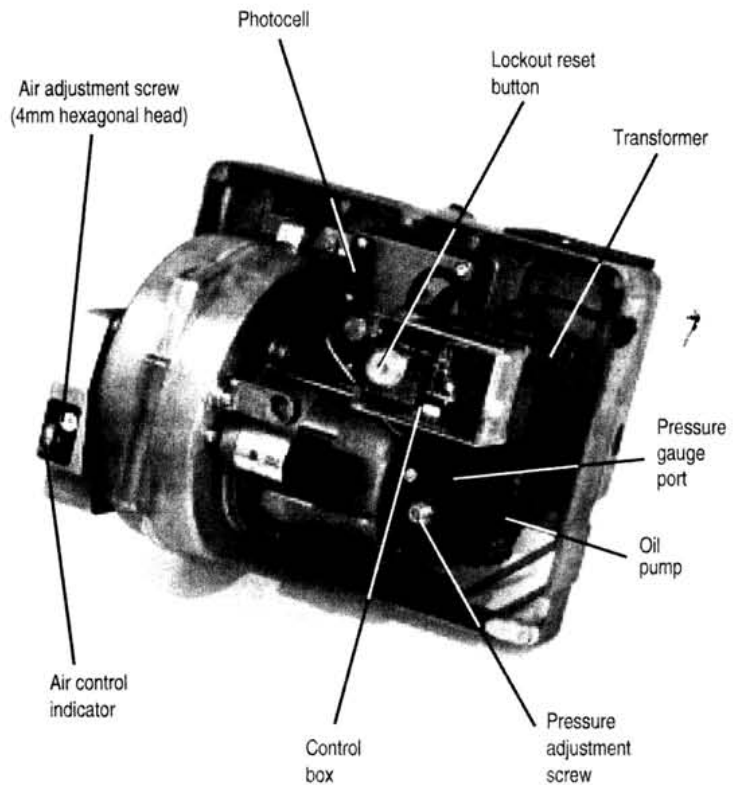


**Fig. 26. Electro Oil Inter B20B Burner.
(50/70 model).**

Combustion Head



Output kW	Fuel	Dimension (mm)	
		A	B
50	28sec. Kerosene	24	10
60	28sec. Kerosene	26	10
70	28sec. Kerosene	28	10
50	35sec. Gas Oil	20	8
60	35sec. Gas Oil	22	8
70	35sec. Gas Oil	24	8



13. Instructions to the User

13.1 *Benchmark* Hand the users instructions and Benchmark Log Book to the user or purchaser for retention and instruct them in the efficient and safe operation of the appliance and the heating/hot water system.

13.2 Advise the user or purchaser of the precautions necessary to prevent damage to the heating/hot water system and to the building in the event of the heating system remaining inoperative during frost conditions.

13.3 Finally advise the user or purchaser that for continued efficient and safe operation of the appliance it is important that adequate servicing is carried out by a qualified engineer at least once per year.

Worcester, Bosch Group will be pleased to discuss and offer a comprehensive maintenance contract.

13.4 Set the system controls to the users requirements.

14. Routine Cleaning and Inspection

14.1 The following should be carried out at least once per year for 28 second Kerosene and twice per year for 35 second Gas Oil, to ensure efficient, trouble free operation.

1. Carry out a pre-service check noting any operational faults.
2. Check and clean the burner.
3. On the CF model check and clean the air intake grille located in the boiler room.
4. On the RS balanced flue model check and clean the air intake ducts at the rear and underneath the boiler and the air intake grille at the end of the terminal.
5. Check and clean the baffle retainer (20/25, 26/32, 32/50 and 50/70 models).
6. Check and clean the cap retainer (32/50 and 50/70 models).
7. Check and clean the baffles.
8. Check and clean the heat exchanger surface.
9. Check the heat shield (20/25, 26/32, 32/50 and 50/70 models).
10. Check the combustion chamber base insulation board.
11. Check that the flue system is unobstructed and clean as necessary.
12. If the appliance has been installed in a compartment check that the ventilation areas are clear.
13. Clean all oil filters.

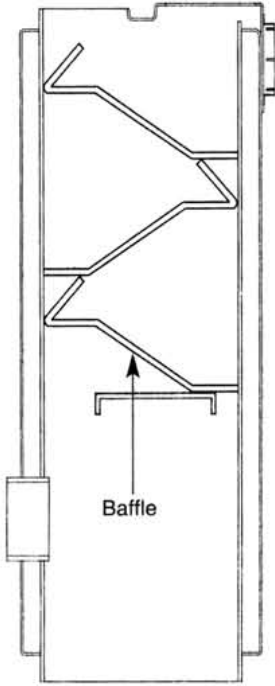
Some of the servicing points are covered more fully in the following instructions:-

14.2 Pre-Service Check

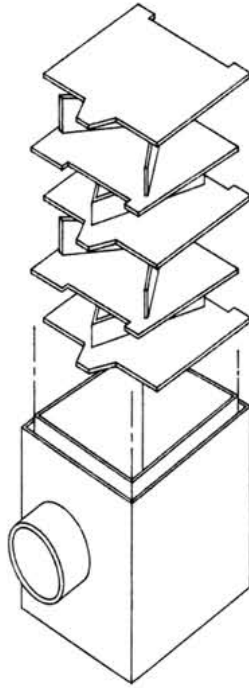
1. Remove the cabinet front and top panels as described in section 5.
2. On the RS balanced flue model remove the burner box cover as described in Section 5.5.

Fig. 27. Location of Boiler Flueway Baffles.

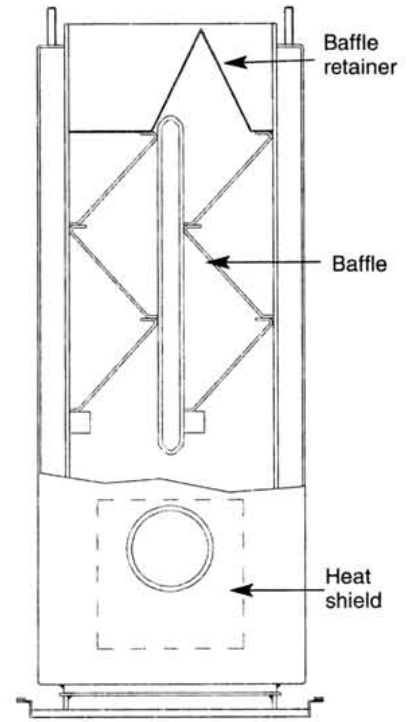
(a) 12/14



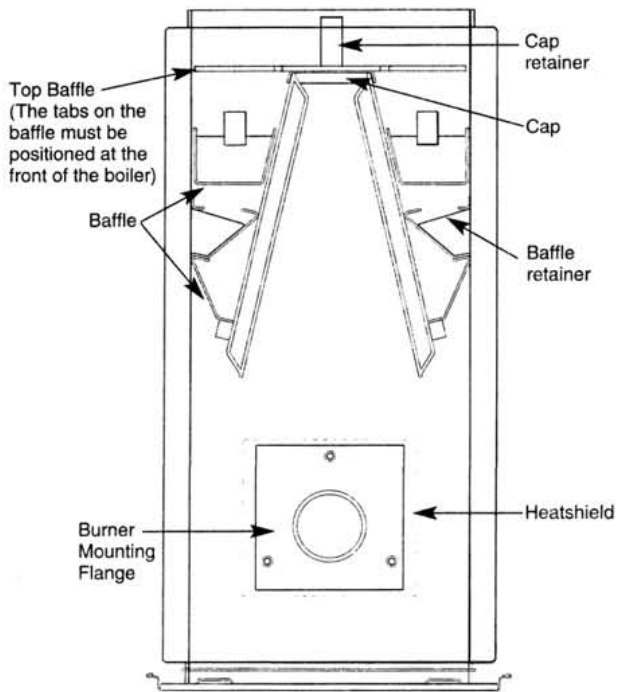
(b) 15/19



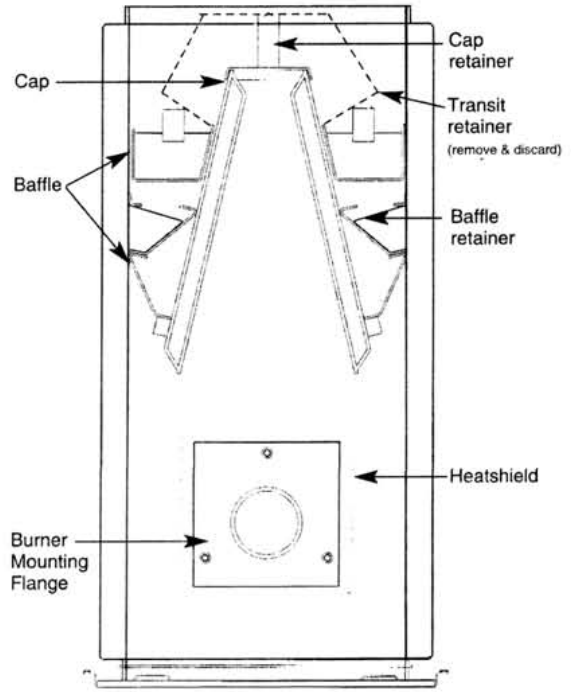
(c) 20/25 and 26/32



(d) 32/50

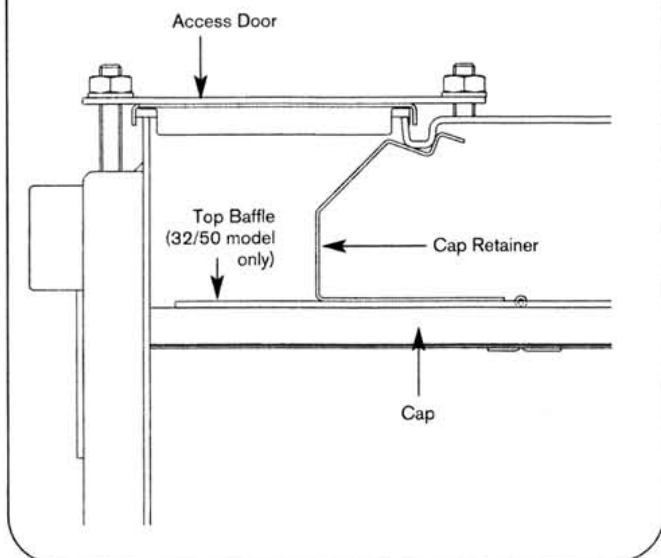


(e) 50/70



ENSURE THAT ALL BAFFLES ARE SEATED IN POSITION

Fig. 28. Location of cap retainer (32/50 and 50/70 models) and location of top baffle (32/50 model only).



3. Operate the appliance and system, noting any faults which may need to be corrected during the service.

14.3 Cleaning the Burner

IMPORTANT: Disconnect the electrical supply at the mains before commencing any servicing. Turn off the oil at the service cock.

1. Remove the burner.

(a) Isolate the oil supply at both the oil tank and the isolating valve situated above the burner on the right-hand side. (See Figs. 2 and 3).

(b) On the RS balanced flue model remove the burner box cover by pulling forwards to release the ball studs. This will be found easier by pulling on one side of the handle first to release two of the ball studs and then repeating on the other side. Take care not to pivot the remaining two ball studs too far around as this will cause damage to the spring clips.

(c) Disconnect the electrical lead from the control box by depressing the two locking ears on the plug and pulling downwards.

(d) On the RS balanced flue model feed the electrical lead back through the grommet seal to give sufficient play to allow withdrawal and inspection of the burner.

(e) Slacken the two M6 burner locking screws, using a 5mm allen key, and remove the burner.

2. Clean the fan impeller using the following procedure:

Electro-oil Inter B9 Burner

(a) Remove the two screws holding the combustion head in position and withdraw the combustion head and air guide collar (where fitted).

(b) Remove the three remaining screws holding the front cover plate in position and withdraw the cover to expose the fan impeller.

(c) Clean both sides of the fan impeller and remove any debris from the burner housing.

(d) Check that the impeller rotates freely.

(e) Clean the air inlet passage and check that the adjustment mechanism operates freely.

(f) Re-assemble the components.

Electro Oil Inter B11

(a) Remove the acoustic fan inlet cover.

(b) Remove the three screws holding the fan cowl in position and remove the cowl noting how the fan control flap is positioned.

(c) Check that the air control flap pivots freely and ensure the air path to the burner head is clear.

(d) Clean both sides of the fan impeller and remove any debris from the burner housing.

(e) Check that the impeller rotates freely.

(f) Re-assemble the components.

Electro Oil Sterling

(a) Remove the air adjustment cover.

(b) Separate the main body of the burner from the burner front by removing the M6 allen screw (located beneath the air adjustment screw), using a 5mm allen key.

(c) Note the position of the air damper adjustment and check the air damper moves freely.

(d) Check the air path to the burner head is clear.

(e) Clean both sides of the fan impeller and remove any debris from the burner housing.

(f) Check the impeller rotates freely.

(g) Re-assemble the components.

Electro Oil Inter B20

(a) Remove the four screws holding the fan cover and remove.

(b) Clean both sides of the fan impeller and remove any debris from the burner housing.

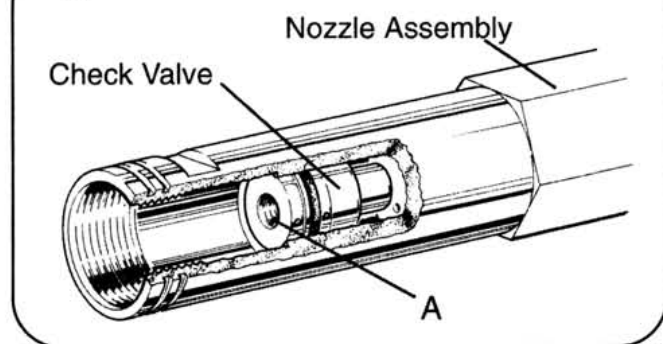
(c) Check that the impeller rotates freely.

(d) Clean the air damper which is attached to the fan cover and check that the adjustment mechanism operates freely.

(e) Re-assemble the complete.

3. Remove the combustion head and thoroughly clean all deposits.

Fig. 29. Mechanical Shut-off Valve.



4. Inspection of Mechanical Shut-off Valve. (See Fig. 29)

a) Remove the nozzle.

b) Fasten an M5 screw, with a minimum length of 30mm, into the threaded hole (A) and pull the screw to withdraw the check valve.

c) Check that the nozzle holder is clear of any debris and clean if necessary.

d) Check that the 3 holes in the check valve are clear of any debris. Discard the check valve if the holes cannot be cleared or if the unit is defective and replace with a new one.

e) Replace in the reverse order.

5. It is strongly recommended that the oil atomising nozzle is replaced at each service. If this is not possible then remove and clean the integral filter, but under no circumstances should the nozzle be stripped into its component parts and never attempt to clean the nozzle tip.

6. Check and reset the electrodes, where necessary, as shown in Figs. 21, 22, 23, 24, 25 and 26.

7. Replace the combustion head and check that the nozzle lies central to the combustion head and the head settings are as shown in Figs. 21, 22, 23, 24, 25 and 26.

8. Withdraw the photocell from its housing and clean.

9. Remove and clean the oil pump internal filter using kerosene or white spirit. The internal filter is accessed by removing the oil pump cover on the Danfoss BFP 11 and Suntec AS47C and by unscrewing and withdrawing the cartridge on the Danfoss BFP 41 as indicated in Fig. 9.

10. It is recommended that the standard flexible oil line is replaced at each yearly service to prevent the possibility of a leak due to ageing.

11. Re-assemble the burner components.

12. Check the sponge O-ring seal located around the combustion head and replace if necessary. It is imperative that this seal is in good condition since failure will cause the flue gases to be re-circulated into the burner inlet, or the room in the case of a CF/LLD appliance.

14.4 Remove the paper element from the external oil filter and replace. If the filter contains a washable element then thoroughly clean in Kerosene or white spirit and re-assemble into the filter.

14.5 Clean the air ducts. (RS balanced flue model only).

1. Remove the rear duct top cover.
2. Shine a light down the rear duct and inspect both the rear and under duct for any sign of debris and clean where necessary using a flexible hose connected to a vacuum cleaner. A short length of garden hose would be suitable for this purpose.
3. Replace the rear duct top cover.
4. Check that the oil bleed holes are clear. These are located in the base of the burner cover box and the bottom front face of the burner housing.

14.6 Clean the Boiler

1. Remove the boiler top access door by releasing the M10 nuts and check the fibreglass rope seal. Replace the seal if necessary.
2. Remove the burner mounting flange by releasing the three M10 nuts and check the fibre glass gasket, it is imperative that this seal is in good condition. Replace the seal if necessary (32/50 and 50/70 models only).
3. Remove and check the baffle retainer, where fitted (20/25, 26/32, 32/50 and 50/70 models). See Fig. 27.
4. Remove the baffles, clean and check their condition. Replace any baffles considered to be badly corroded.
5. Remove and check the cap retainer, where fitted (32/50 and 50/70 models only). See Figs. 27d, 27e and 28.
6. Remove the cap (32/50 and 50/70 models only) and check the 'rocksulate' gasket. Replace the seal if necessary.
7. Thoroughly clean all of the heat exchanger surfaces using a stiff wire brush and vacuum clean all loose debris from the combustion chamber. Take care not to damage the base insulation!
8. Remove and check the heat shield where fitted (20/25, 26/32, 32/50 and 50/70 models). (See Fig. 27).
9. Check the combustion chamber base insulation and replace if there is any sign of damage.
10. Check and clean the flue.
11. Replace the items in reverse order noting the baffle positions shown in Fig. 27.

14.7 Fire Valve.

Check that a fire valve is fitted to the incoming oil line with the body located outside the premises and the detection element located within the appliance case. A fire valve clip is provided for this purpose as shown in Figs 2 & 3. Test the operation of the fire valve to ensure that the mechanism operates and that the oil supply is completely isolated.

NOTE: The fire sensing element must be located on the top face of the burner surround box on RS balanced flue models, as shown in Fig.3, to allow quick detection of a dangerous situation.

14.8 Recommission the Burner.

1. Connect the flexible oil supply hose to the isolating valve and tighten sufficiently to form a good seal. Where a double pipe system is being used connect the oil return flexible hose to return pipe fitting.
2. With the sponge O-ring gasket around the burner blast tube insert the burner into the housing tube. Push the burner firmly forward to compress the gasket and tighten the two locking screws.

Note: It is important that a good seal is made between the burner and the boiler to prevent re-circulation of the gases from the combustion chamber to the burner inlet, or the room in the case of a CF/LLD appliance.

3. On the RS balanced flue model feed the electrical lead back through the hole in the burner surround housing (in the reverse

order to that described in 11.2) and fit the grommet into the hole ensuring a seal is made.

4. Reconnect the electrical lead plug into the control box.
5. Turn on the oil supply at the service cock.
6. Recommission the burner as described in Section 12.

15. Short Parts List

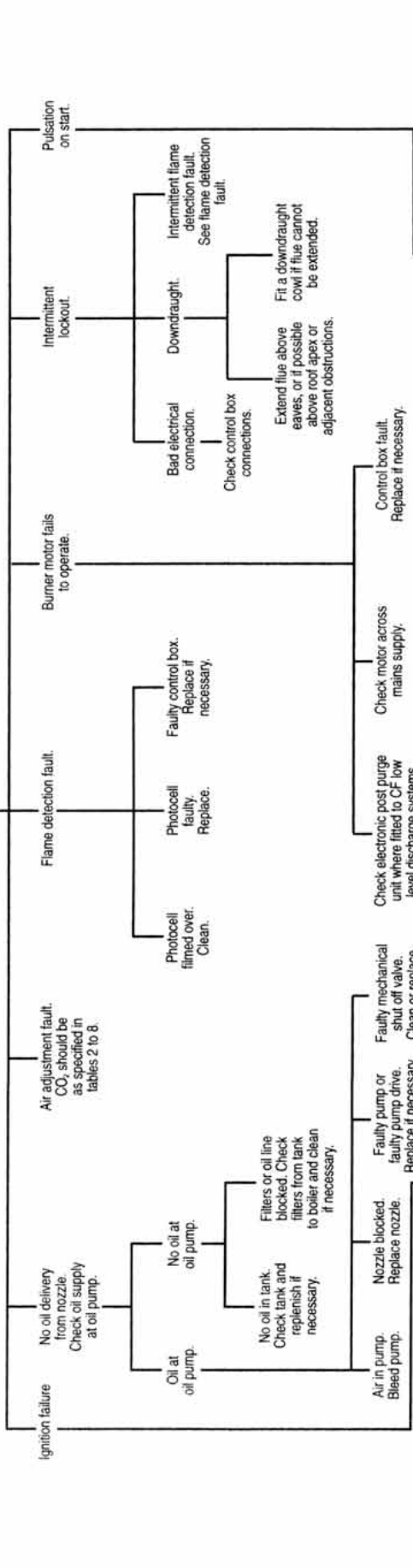
Part	Manufacturers Reference	Qty	Worcester Part No.
Burner for 12/14	Bentone B9A	1	8 716 104 431 0
B9A Combustion Head	PL 6/7/21.5/10-E x 78mm	1	8 716 157 041 0
Burner for 15/19	Bentone B9B	1	8 716 142 705 0
B9B combustion Head	PL 6/7/21.5/10 x 78mm	1	8 716 156 697 0
Burner for 20/25	Bentone B11C	1	8 716 104 432 0
B11C Combustion Head	PL 10/4/24/10 x 78mm	1	8 716 142 784 0
Burner for 26/32	Bentone Sterling 40	1	8 716 142 700 0
Sterling 40 Combustion Head	PL 6/7/21.5/10 x 78mm	1	8 716 156 697 0
Burner for 32/50	Bentone B20C	1	8 716 104 546 0
B20C Combustion Head	PL10/8/10/6/19/10-E x 78mm	1	8 716 104 769 0
Burner for 50/70	Bentone B20B	1	8 716 104 547 0
B20C Break Plate	PL 21.5/10 (type K)	1	8 716 156 518 0
B20C Blast Tube	Type K x 94mm	1	8 716 142 739 0
Burner control 1.	Control Box Satronic TF 832.3	1	8 716 156 648 0
B9, B11 and B20	Photocell Satronic MZ770	1	8 716 142 735 0
Sterling 40	Photocell Satronic MZ770	1	8 716 156 692 0
	Control Box Base Satronic S01 S701	1	8 716 142 782 0
Ignition Electrode		1	8 716 142 752 0
Motor B9	AEG or Simel 70 W	1	8 716 156 597 0
Motor B11 and B20	AEG (FHP) 90W	1	8 716 142 732 0
Motor Sterling 40	AEG (FHP) 90W	1	8 716 156 645 0
Oil Pump B9	Danfoss BFP41L3	1	8 716 142 743 0
Oil Pump (B11, B20 and Sterling 40)	Danfoss BFP11L3	1	8 716 142 736 0
Transformer	Danfoss EBI 052F0030 (excludes cable)	1	8 716 156 696 0
Mechanical Shut-Off Valve		1	8 716 156 658 0
Flexible Oil Line Kit	Worcester	1	8 716 156 663 0
Burner 'O' Shaped Gasket	Worcester	1	8 716 140 902 0
Control Thermostat	Siebe K36-P2312	1	8 716 142 309 0
Automatic Reset High Limit Thermostat	Siebe LO7-P1022	1	8 716 142 311 0
Manual Reset High Limit Thermostat	Siebe LM7-P5075	1	8 716 142 310 0

16. Fault Finding

LOCKOUT

INDICATED BY RED LAMP ON CONTROL BOX

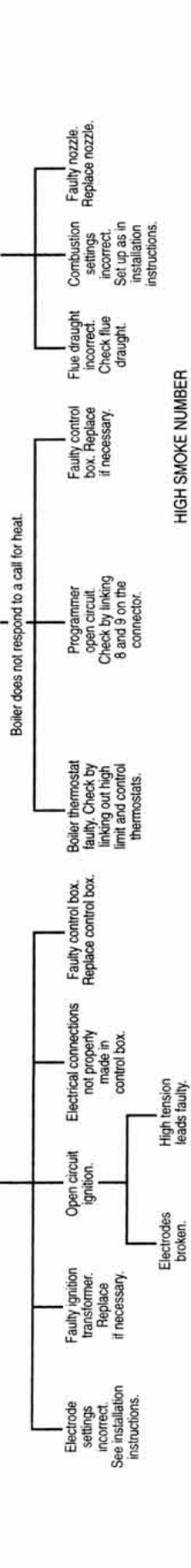
To Re-set wait 2 minutes and press re-set button



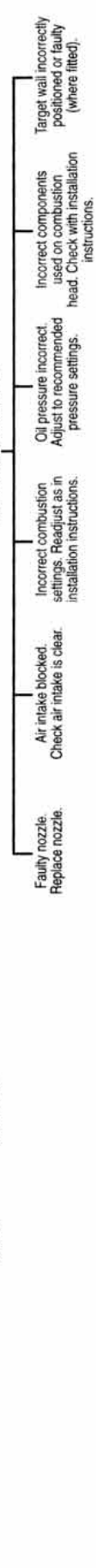
IGNITION FAILURE

BURNER FAILS TO START

PULSATION ON START

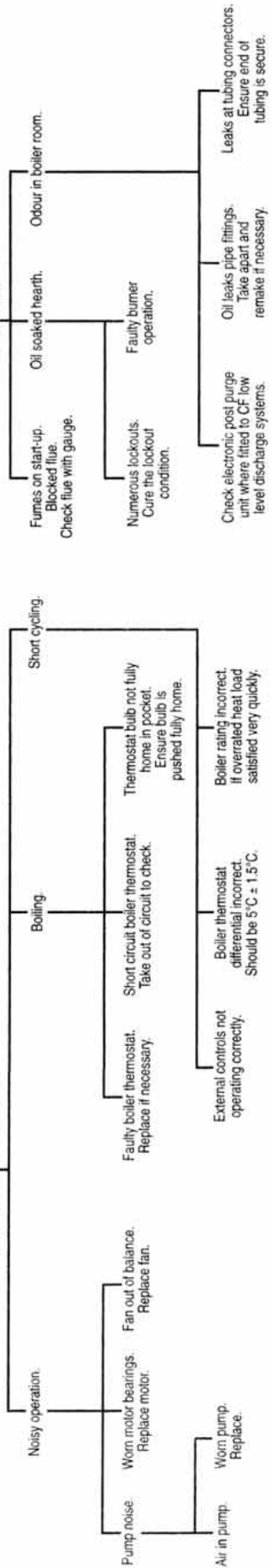


HIGH SMOKE NUMBER



FAULTY BOILER OPERATION

OIL SMELLS



www.worcester-bosch.co.uk



Worcester, Bosch Group, Cotswold Way, Wamdon, Worcester WR4 9SW.
Telephone: 01905 754624, Fax: 01905 753130.
Technical Helpline 08705 266241.

Worcester, Bosch Group is a trading name of BBT Thermotechnology UK Limited.

This booklet is accurate at the date of printing but will be superseded and should be disregarded if specifications and/or appearances are changed in the interests of continued improvement.

All goods sold are subject to our official Conditions of Sale, a copy of which may be obtained on application.

8 716 114 743a 03/08