



O W N E R G U I D E



MODEL BR417
(G.C.32-032-07)
Inset Live Fuel Effect
Gas Fire
with
Ultimate
or
Superflame
Front



*This Owner Guide is intended to help you care for your Valor gas fire.
Please read carefully before using your gas fire and keep for future reference.
This Owner Guide gives sufficient details to enable your gas fire to be operated and maintained.*

IMPORTANT.
Please keep your Owner Guide in a safe place together with the Installer Guide.

As supplied, this appliance is for use with natural gas (G20)
When converted using Valor conversion kit no. 591149 this
appliance is for use with propane gas (G31)
This appliance is for use in the United Kingdom (GB) and the
Republic of Ireland (IE) only.

C U S T O M E R C A R E

Thank you for choosing Valor.

All Valor gas fires are designed to meet the most stringent quality, performance and safety requirements to provide our customers with many years' trouble-free service.

Your owner guide aims to improve your understanding and appreciation of your Valor gas fire by providing simple and informative instructions to ensure that you benefit from the excellent performance and features it has to offer.

If you require further assistance or any advice about gas in general, the **Valor AdviceLine** will be pleased to help.

Please telephone **0345-626341** (local call rates apply in the United Kingdom).

FOR OTHER USEFUL TELEPHONE NUMBERS SEE INSIDE BACK COVER.

C O N T E N T S

	Page
Safety.....	3
Major Dimensions.....	4
Gas Consumption.....	4
Operating the Fire.....	5
Cleaning.....	6
Fuel Bed Refitting.....	7
Maintenance.....	8
Useful Telephone Numbers.....	Inside back cover

SAFETY

IF YOU SMELL GAS

DON'T SMOKE

EXTINGUISH ALL NAKED FLAMES

DON'T TURN ELECTRICAL SWITCHES ON OR OFF

TURN OFF THE GAS SUPPLY AT THE METER

OPEN DOORS AND WINDOWS TO GET RID OF THE GAS

IMMEDIATELY CALL THE GAS EMERGENCY SERVICE - SEE YOUR LOCAL TELEPHONE DIRECTORY

1. As with any gas appliance, this fire must be installed by a competent person. In the United Kingdom, installation must be in accordance with the latest edition of the Gas Safety (installation & use) Regulations.
In the Republic of Ireland, installation must be in accordance with all national and local regulations in force.
2. If the fire is intended to be installed to a chimney which was previously used for solid fuel, please note that the chimney must be swept prior to installation.
3. On no account must the fire stand on carpets or other combustible materials. The fire must stand behind a non-combustible hearth surface. The hearth material must be at least 12mm thick. Its top surface should be 50mm above floor level to discourage placing carpets. Rugs or other combustible materials over the hearth. The minimum size of the hearth is shown in figure 1.
4. If the fire is intended to be installed against a wall with combustible cladding, the cladding must be removed from the area covered by the outer surround (see figure 1).
5. The minimum height from the top surface of the hearth to the underside of any shelf made from wood or other combustible material and which is not more than 150mm deep is 750mm. (This will give a clearance of 150mm above the top edge of the outer surround).
for shelves deeper than 150mm add 12.5mm to the above clearance for every 25mm of additional shelf depth.
6. Never put any paper or other material on the fire. Never add any extra coals above the number stated in these instructions. This could cause a safety hazard.
7. It should be appreciated that although this appliance conforms to all the applicable standards, it is a decorative fuel effect heating appliance and certain parts of its surface will become hot. A suitable guard that complies with BS 6539 or 6778 should be used for the protection of young children, the elderly and the infirm. Such a guard is also recommended for the protection of pet animals.
8. Always switch the fire off and allow to cool before handling. Note that this appliance retains heat for some time after it has been switched off.
9. Never hang clothing, towels or any other fabrics over the fire.
10. This appliance is fitted with a device that will automatically shut off the supply of gas to the fire if, for any reason, the pilot goes out. If this device does operate or if the fire is turned off accidentally or intentionally, always wait three minutes before attempting to relight.
11. Soft wall coverings (e.g. embossed vinyl etc.) are easily affected by heat. They may, therefore, scorch or become discoloured when close to a heating appliance. Please bear this in mind when having a heating appliance installed and when redecorating.

Please note

When operating your fire for the first time, some vapours may be given off which may cause a slight odour and could possibly set off any smoke alarms in the immediate vicinity. These vapours are quite normal with new appliances. They are totally harmless and will disappear after a few hours use.

This fire is supplied with ceramic "coals" to simulate a real coal fire. These items are safe to handle and are designed for easy refitting if removed.

After some use, the ceramic walls and coals may change colour. This is quite normal.

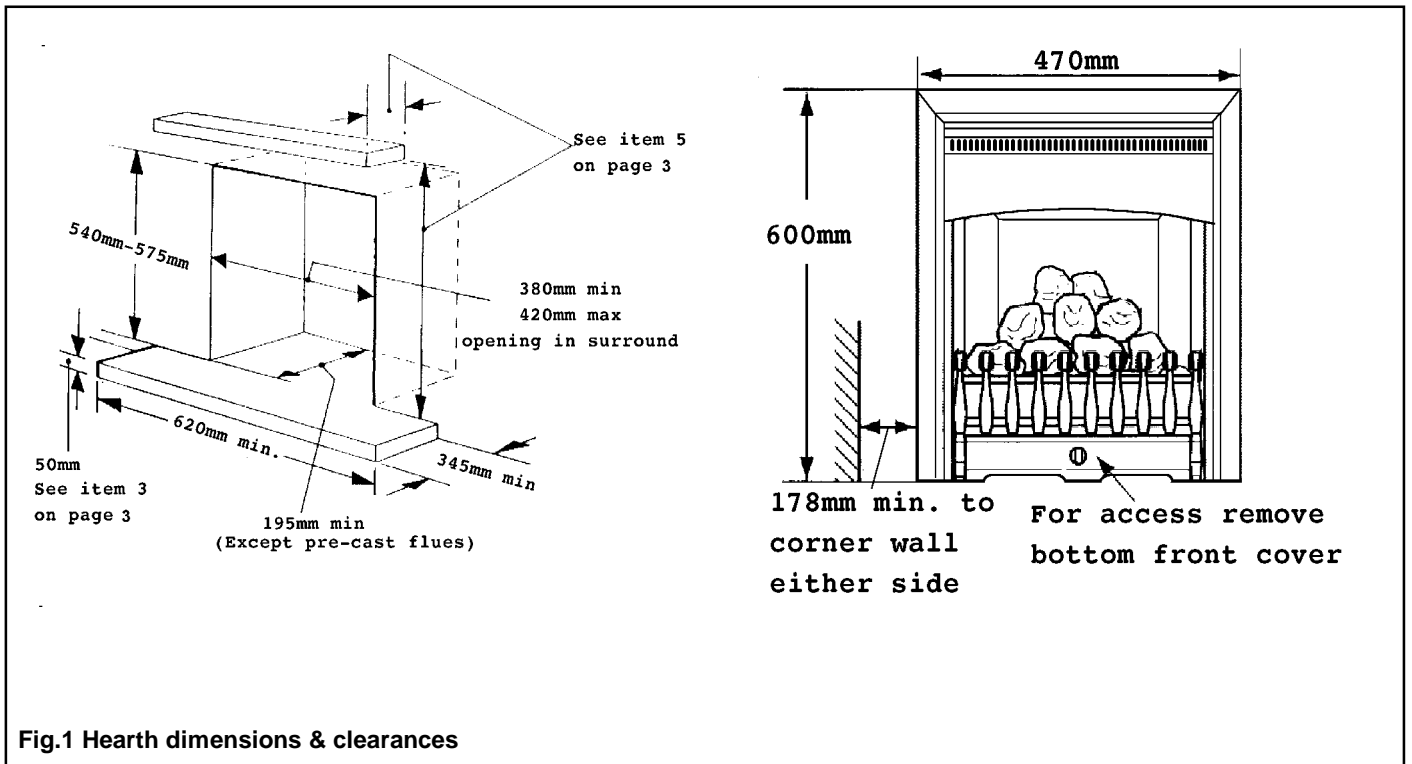

Fig.1 Hearth dimensions & clearances

Please observe the caution statements on the previous page.

GAS CONSUMPTION

Natural gas appliances have a maximum gas input at the high setting of 6.0kW (Gross) and a minimum gas input at the low setting of 2.2kW (Gross).

Propane gas appliances have a maximum gas input at the high setting of 6.1kW (Gross) and a minimum gas input at the low setting of 3.6 kW (Gross).

To calculate the running cost of this fire, multiply the gas consumption (gas input) by the cost of gas which you will find on your gas bill.

$$\text{GAS CONSUMPTION (HEAT INPUT)} \times \text{COST OF GAS} = \text{RUNNING COST}$$

Natural gas appliances have a heat output of 3.5kW at the high setting and 1.1kW at the low setting.
 Propane gas appliances have a heat output of 3.6kW at the high setting and 1.8kW at the low setting.

OPERATING THE FIRE

The flame sensing & flue blockage safety system.

For your safety, this appliance is fitted with a flue blockage safety device that will shut down the appliance in the event of abnormal flue conditions. ***This device is NOT a substitute for an independently mounted Carbon Monoxide detector.***

The device will also automatically shut off the gas supply to the fire if the pilot flame goes out due to lack of oxygen or for any other reason.

If the device starts to shut off the gas frequently, get expert advice.

The system incorporates a probe that senses that the heat from the pilot flame is correct. If this probe is cool, the device will prevent any gas flow unless the control knob is kept depressed at the PILOT/IGN position.

If, for any reason, the flames go out when the fire is hot or if the fire is turned off when hot, always ***wait at least three minutes before attempting to relight.***

To light the fire

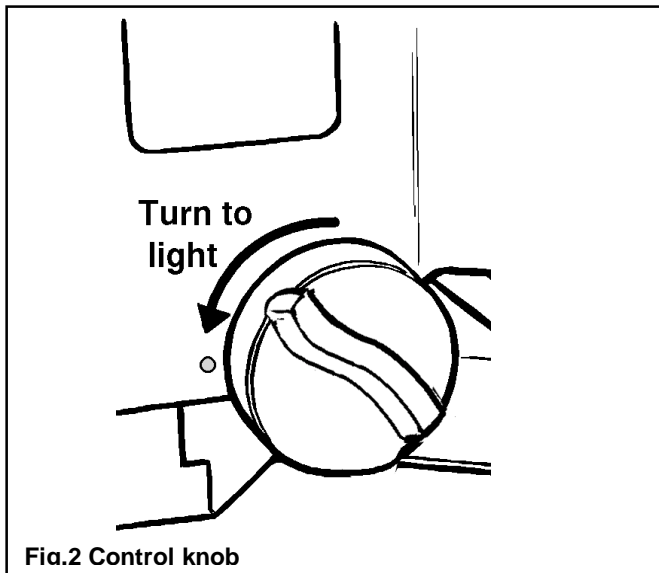

To get access to the control knob, remove the bottom front cover (Figure 1).

Depress the control knob and turn anticlockwise towards the PILOT/IGN position (Figure 2). A spark should be generated at the pilot while turning. The spark should ignite the pilot. The pilot flame can be seen below round coal at the front left side.

Keep the button at the PILOT/IGN position for a further ten seconds. This will prevent the flame sensing device from shutting off the gas while its probe warms up as explained previously.

When the pilot is alight and stable, partially depress the knob and turn to "LOW". The pilot should then light the main burner at its low setting. There may be a delay of up to four seconds between the pilot lighting and ignition of the gas at the main burner. This is normal and is due to the time required to fill the main burner compartment with sufficient gas for ignition.

When the burner is main burner is alight at its low setting, partially depress the knob and gradually turn it anti-clockwise until the burner is at your desired level. The burner flames will gradually increase until the knob reaches the "HIGH" position.

To turn off

To turn the main burner off but leave the pilot alight, partially depress the knob and turn to PILOT/IGN.

To turn the fire fully off, partially depress the knob and turn to OFF.

While cooling, the coals may make some crackling noises. This is quite normal.

Lighting with a taper (see figure 3)

In the unlikely event of failure of the ignition spark, the pilot can be lit by a taper or long spill. Insert the taper or spill alongside of the left side wall of the fire box, Depress the control knob, turn it to PILOT/IGN

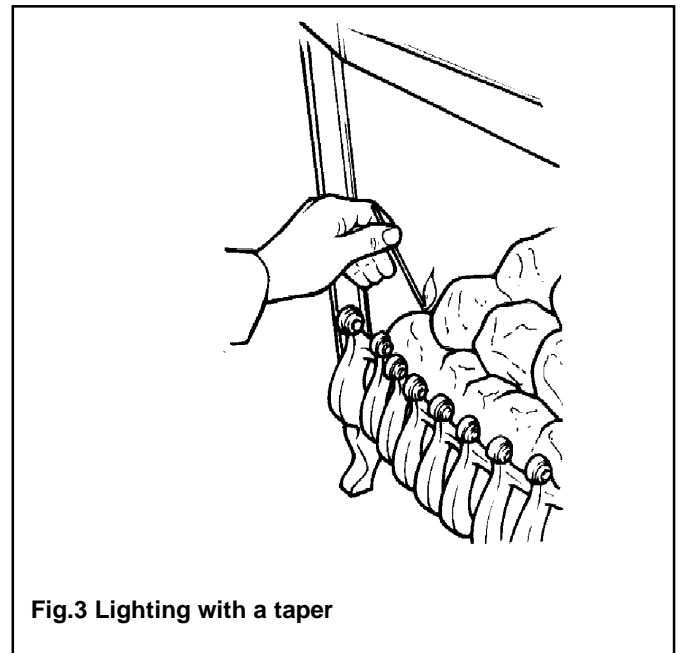

The appliance will operate to its maximum potential if the flue is primed during the first 20 – 30 minutes of operation. To do this, simply turn the control knob to its highest setting. This will also burn off any carbon deposits that may have formed during previous operations.

If operating the appliance for long periods it is beneficial to occasionally change settings. This will also help to remove any carbon deposits that may form during operation.

CLEANING

Turn the fire off and allow it to cool before attempting any cleaning. Note that the fire will retain heat for some time after it has been turned off.

If large pieces of debris are found anywhere in the fireplace, have the chimney inspected before further use.

Metal parts

Clean the metal parts with a slightly damp cloth and then dry. ***Do not use abrasive cleaners, they could scratch the surface.***

Coals

Light coatings of soot will usually be burnt off during the normal operation of the fire. If, however, deposits of soot or particles of sand, mortar, etc. from the chimney accumulate to 3mm ($\frac{1}{8}$ in) or more, these should be removed from the coals by dismantling them and cleaning with a soft brush. We suggest that you remove

the coals in the reverse order to that shown in the fuel bed refitting instructions. *Cleaning with a vacuum cleaner is not recommended because it may damage the coals.*

Ceramic fire box walls

Clean with a dry soft brush. *Cleaning with a vacuum cleaner is not recommended because it may damage the coals.*

Ceramic burner

Remove any deposits of soot or other foreign matter from the solid areas of the burner with a dry soft brush. Be careful not to brush any particles into the open slots. Remove any particles from the slots with a vacuum cleaner fitted with a soft brush attachment. ***Do not poke wire, etc. into the slots in the burner.***

FUEL BED REFITTING

If the fuel bed components are dislodged or removed, they must be refitted as follows:

Only the fuel bed parts supplied with this appliance or authorised Valor replacements must be used. Never add extra coals above the number stated in these instructions.

1. With its feather edge at the top, place the ceramic rear wall into the channel at the back of the fire box. Push the wall flat against the rear of the fire box. (See figure 4).

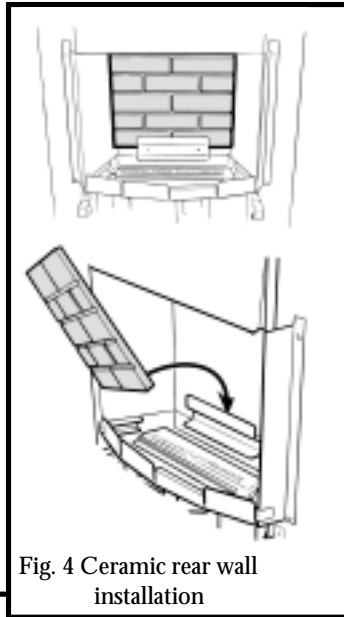

Fig. 4 Ceramic rear wall installation

2. Place the two halves of the front base coal in the burner compartment so that they rest on the ledges at the sides and front. Pull the coals forward so that they are immediately behind the front rim of the burner compartment (See fig. 5).

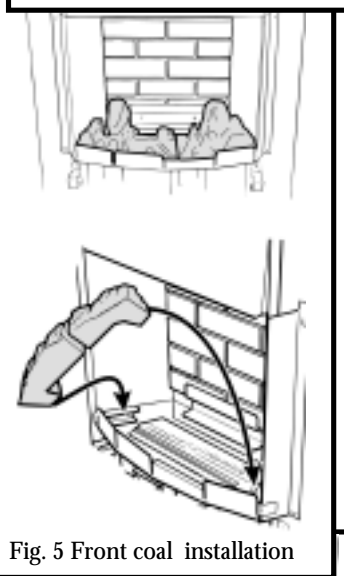

Fig. 5 Front coal installation

3. Place the rear base coal in the burner compartment behind the front coal. Its rear face should touch the rear ceramic wall (See figure 6).

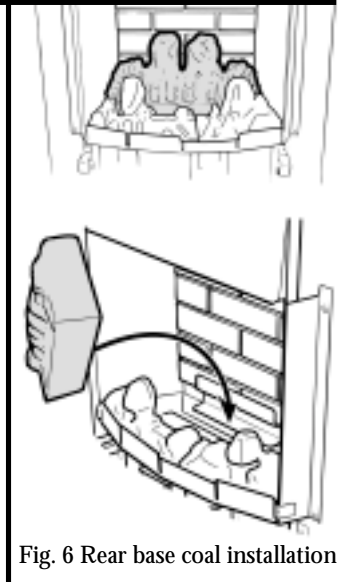

Fig. 6 Rear base coal installation

4. The ceramic side walls are marked at the rear bottom corners "L" (Left side) & "R" (Right side). Place the side walls against the sides of the fire box and in the recesses at the sides of the base coals. The markings "L" & "R" should be at the back bottom corners and facing to the centre of the back of the firebox (See figure 7).

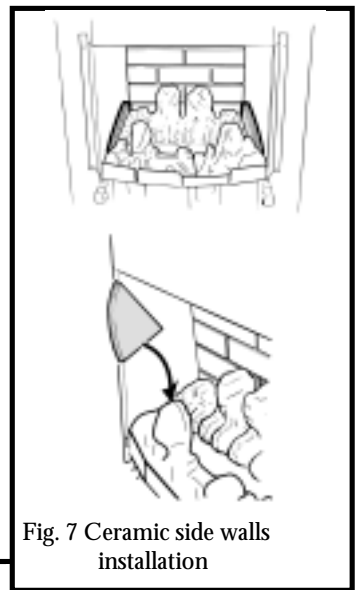

Fig. 7 Ceramic side walls installation

5. Install the 5 loose coals as follows. The smooth surfaces of the coals should be at the bottom and back.

5.1 Select the two largest coals. Place them in the central two valleys of the front coal (See figure 8).

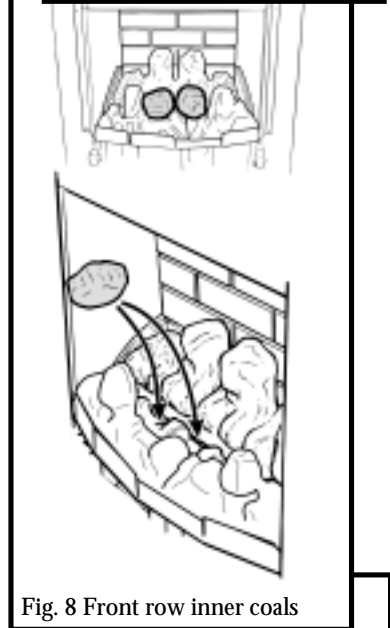

Fig. 8 Front row inner coals

5.2 Place the three remaining coals behind and approximately midway between each of the coals in the front row (See figure 9).



Fig. 9 Middle row of coals

MAINTENANCE

Debris from the chimney

The opening at the back of the appliance must be always kept clear of obstruction. If the chimney has previously been used for coal fires or is of normal construction it is possible that loose mortar and soot can fall behind the appliance. This, in time, may build up until the flue becomes restricted or even blocked. The chimney should be checked annually to ensure continued clearance of the combustion products and to ensure that no excessive build up of soot or other debris occurs. The appliance should be serviced regularly in order to ensure good mechanical operation.

It is important that this work is carried out by a competent person such as a CORGI registered installer.

General servicing

If you require any attention to your fire, contact your supplier mentioning the model number. It will also be helpful if the appliance serial number is quoted. This will be found on a tied label next to the control knob. It is visible when the bottom front cover is removed.

In the United Kingdom it is the law that a landlord must have any gas appliance and pipework which is situated in a tenant's premises checked for safety at least every 12 months. We recommend that all gas appliances, wherever situated, are checked annually by a competent person (In the UK, a CORGI registered installer).

The ceramic fuel bed items are customer replaceable. When ordering please quote the number shown below.

<u>Description</u>	<u>Part No</u>
Rear wall	545999
Front base coal halves	569449
Rear base coal	569459
Pack of 5 top coals	569469
Right side wall	546039
Left side wall	546049

When fitting replacement parts, follow the instructions contained in this guide. It is important that only Valor approved parts are used for maximum safety.

USEFUL TELEPHONE NUMBERS

To help us quickly help you, please try to have the following information available before you contact us:

- a) Your Post Code.**
- b) Type of fire.**
- c) Model/Name.**
- d) Serial Number.**
- e) The fault, problem or request.**

General advice about gas and your gas fire:

VALOR ADVICELINE 0345 626341.

To report faults or arrange for your fire to be serviced:

VALOR SERVICE 0121 386 6203.

To order spares or for sales information:

VALOR SALES 0121 386 6260.

CALLERS IN THE REPUBLIC OF IRELAND

Call 0044 121 373 8111

Safety First.

Valor fires are CE Approved and designed to meet the appropriate British Standards and Safety Marks.



Quality and Excellence.

At the heart of every Valor fire.

All Valor fires are manufactured to the highest standards of quality and excellence and are manufactured under a BS EN ISO 9001 quality system accepted by the British Standards Institute.



The Highest Standards

Valor is a member of the Society of British Gas Industries which works to ensure high standards of safety, quality and performance.



Careful Installation

Valor is a Corgi registered company. All our gas fires must be installed by a competent Corgi Registered Installer in accordance with our Installer Guide and should not be fitted directly on to a carpet or floor of combustible material.



Masters of the living flame.

Valor Heating, Erdington, Birmingham B24 9QP

Because our policy is one of constant development and improvement, details may vary slightly from those given in this publication