

For the User



Instructions for use ecoMAX



GB

Wall hung room sealed fan assisted condensing boilers

ecoMAX 613/2	E
ecoMAX 618/2	E
ecoMAX 622/2	E
ecoMAX 824/2	E
ecoMAX 828/2	E
ecoMAX 835/2	E



Table of contents

1 General information

1 General information	2
1.1 For your information	2
1.2 Key to symbols	2
1.3 Liability	2
1.4 Specified use	3
1.5 EC designation	3
2 Safety instructions	3
2.1 Setup and adjustments	3
2.2 Gas smell	3
2.3 Modifications in and around the boiler	3
2.4 Explosive and flammable materials	3
2.5 Inspection	3
3 Factory guarantee	4
3.1 Your guarantee	4
3.2 Registering with us	4
3.3 Immediate help	4
4 Operation	4
4.1 Overview	4
4.1.1 Operating controls	4
4.1.2 Advanced multifunctional system display	5
4.2 Initial checks before turning ON	5
4.2.1 Opening the service valves	5
4.2.2 Checking the water contents	5
4.3 Domestic hot water operation	6
4.3.1 Setting the maximum domestic hot water temperature control (ecoMAX 800 series only)	6
4.3.2 Warmstart operation (ecoMAX 800 series only)	6
4.3.3 Obtaining hot water (ecoMAX 800 series only)	7
4.4 Heating operation	7
4.4.1 Setting the maximum radiator temperature control	7
4.4.2 Setting the external controls	8
4.5 Status displays	8
4.6 Resetting the appliance	9
4.7 Turning the boiler OFF	10
4.7.1 To turn OFF the central heating only (Summer mode)	10
4.7.2 To turn OFF central heating and hot water for short periods of time	10
4.8 Turning the boiler OFF (ecoMAX 600 series only)	10
4.8.1 To turn OFF the central heating	10
4.8.2 To turn boiler OFF for short periods of time	10
4.9 Troubleshooting	11
4.10 Care and maintenance	11
4.11 Frost-protection	11

2 1 General information

1.1 For your information

Thank you for choosing a Vaillant boiler. The information given in this booklet will enable you to obtain the best performance from your boiler.

3 ecoMAX 800 series provides both central heating and domestic hot water, with the domestic hot water supplied directly from the boiler. The boiler will operate automatically to provide domestic hot water whenever a hot water tap is opened, and automatically adjusts to meet the demand for both central heating and domestic hot water in the most economical way.

4 ecoMAX 600 series provides central heating and domestic hot water where a separate indirect hot water cylinder is also incorporated to the system.

4 The benchmark logbook should be completed by the installer and/or the commissioning engineer and handed to the user.

5 All CORGI Registered Installers carry a CORGI ID card, and have a registration number. Both should be recorded in your Benchmark Log Book. You can check your installer by calling CORGI direct on 01256 372300.

If, after reading these instructions, you have any questions on the operation of the boiler, please contact either your installer or Vaillant Technical Department.

1.2 Key to symbols

 **Important Note**

 **This symbol is used to indicate important instructions.**

- This symbol is used to indicate a required step.

1.3 Liability

 **We can accept no liability whatsoever for damage or injury resulting from failure to observe these instructions.**

1.4 Specified use

Vaillant ecoMAX appliances are made to fulfil the latest technical specifications and official safety regulations. These appliances are designed as boilers for use in central heating and hot water supply systems.

If the appliances are used for purposes other than or in excess of these specifications, this shall be classed as incorrect operation, and neither the manufacturer nor supplier will accept any liability for resulting damage or injury.

Use of this type is entirely at the owner's risk.

The term "specified use" also covers observance of the operating and installation instructions, along with adherence to the servicing schedules.

1.5 EC designation



The purpose of EC designation is to certify that the boiler complies with the requirements of the directives covering gasfired appliances (Council directive 90/396/EEC) and electromagnetic compatibility (Council directive 89/336/EEC).

These appliances also comply with the requirements of the directive on operating efficiency (Council directive 92/42/EEC).



 **Vaillant Ltd. support the Benchmark initiative. Within the information pack, you will find a Benchmark Log Book. It is very important that this is completed correctly at the time of installation, commissioning and handover to the user.**

2 Safety instructions

2.1 Setup and adjustments

Installation and adjustment of the boiler as well as service maintenance and repair of the boiler may only be carried out by a competent person in accordance with the Gas Safety (Installation and Use) Regulations 1998. (In the U.K. "CORGI". Registered installers undertake the work to a safe and satisfactory standard).

If the boiler is installed in a compartment do not obstruct any purpose provided ventilation openings, and do not use the compartment for storage purposes.

2.2 Gas smell

If you smell gas or suspect a gas leak:

- Turn off the boiler
- Do not switch any electrical switches in the hazardous area on or off
- Do not smoke in the hazardous area
- Turn off the gas supply at the gas meter
- Ventilate the room
- Consult your gas supplier, service agent or other competent person.

2.3 Modifications in and around the boiler

No modifications may be made to the following items:

- The boiler
- The gas, water and electrical supply
- The flue system
- The safety valve for the heating water
- Any structural changes around the appliance that could affect the operational safety of the boiler.

2.4 Explosive and flammable materials

Do not use or store any explosive or highly flammable materials (e.g. gasoline, paper or paint) near to the appliance.

2.5 Inspection

The boiler should be serviced annually. We recommend that you sign a service agreement with your service agent or Vaillant Ltd.

3 Factory guarantee

4 Operation

3 Factory guarantee

3.1 Your guarantee

Vaillant undertakes to rectify any manufacturing defect that occurs within twenty-four months of the installation date.

3.2 Registering with us

Registration is simple. Just complete the Guarantee Registration Card and return to Vaillant within 30 days of installation. Your details will then be automatically registered within the Vaillant scheme.

 **Note:**
No receipt will be issued.

3.3 Immediate help

If your Vaillant boiler develops a fault your first action should be to contact your installer, as his professional assessment is needed under the terms of our Guarantee. If you are unable to contact your installer, phone Vaillant Service Solutions: 0870 6060 777

4 Operation

4.1 Overview

4.1.1 Operating controls

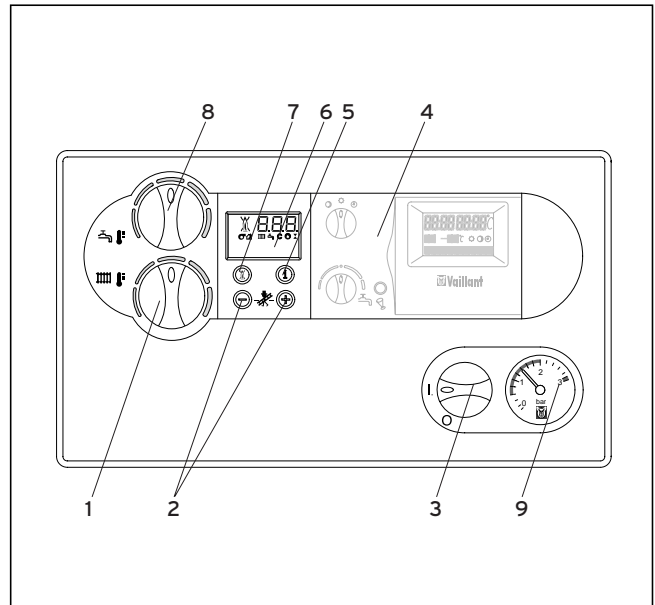

Fig. B.1 Operating controls

For access to the controls pull the front flap from its catches, located at the top right and left hand corners and pull downwards.

The following can be seen:

- 1 Maximum radiator temperature control (page 12)
- 2 The "+" and "-" buttons for the display panel
- 3 Main ON/OFF control (pages 10 and 14)
- 4 Built in control/timer module (if fitted)
- 5 The "i" information button
- 6 Boiler display indicates current operating mode and additional information
- 7 "Reset" button: (see page 13)
- 8 Maximum hot water temperature control and warm-start ON/OFF control (page 11)
(ecoMAX 800 series only)
- 9 Pressure gauge displaying the pressure in the heating system

4.1.2 Advanced multifunctional system display

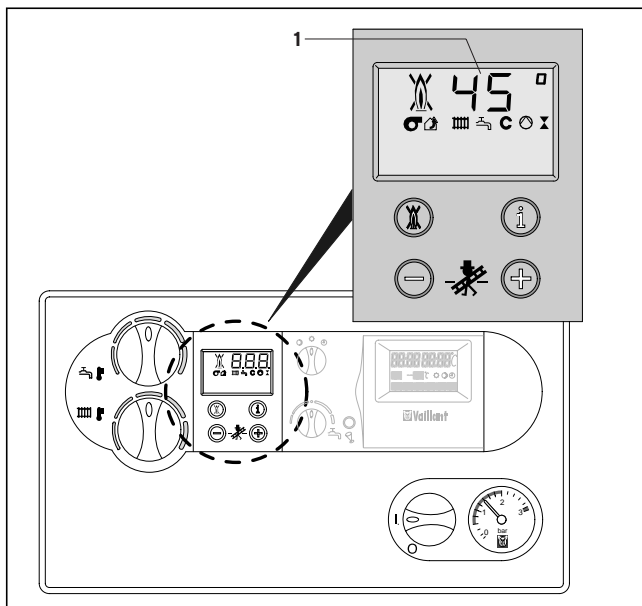

Fig. B.2 Advanced multifunctional system display

The boiler system display (Fig. B.2) shows - during normal operation - constant information on the heating system flow temperature (Fig. B.2. example gives flow temperature of 45 °C). In the event of a malfunction, this temperature display is replaced by the relevant error code (see page 15). The displayed also give the following information:

- 1 Indication of the current heating system flow temperature, or display of a status (see page 11) or error code
- Fan speed malfunction
- Fan speed malfunction
- Heating mode active
- Hot water on (**ecoMAX 800 series only**)
Illuminated: hot water demand
Flashing: warmstart demand (burner is on)
- C** Warmstart is on (**ecoMAX 800 series only**)
Illuminated: warmstart turned on
Flashing: warmstart demand (burner is on)
- Internal pump is running
- Gas valve is activated
- Flame crossed out:**
Boiler is at lock out and will display fault code
- Normal flame:**
Correct burner operation

4.2 Initial checks before turning ON

4.2.1 Opening the service valves

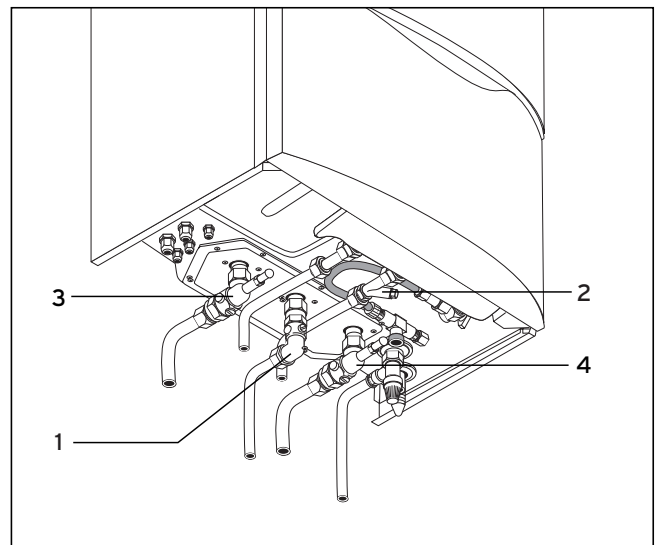

Fig. B.3 Opening the service valves

- Ensure the cold water service valve (2) is open. This can be checked by opening a hot water tap and ensuring water flows.
- Ensure that the service valves in the heating flow and return (4 and 3) and the gas service valve (1) are open.

The flow, return and gas service valves are open when the line marking has the same direction as the pipe.



The pressure relief valve is provided for safety reasons and must not be interfered with.



Note:
A bottom cover is fitted to the appliance.
The service valves are fitted behind this cover.

4 Operation

4.2.2 Checking the water contents

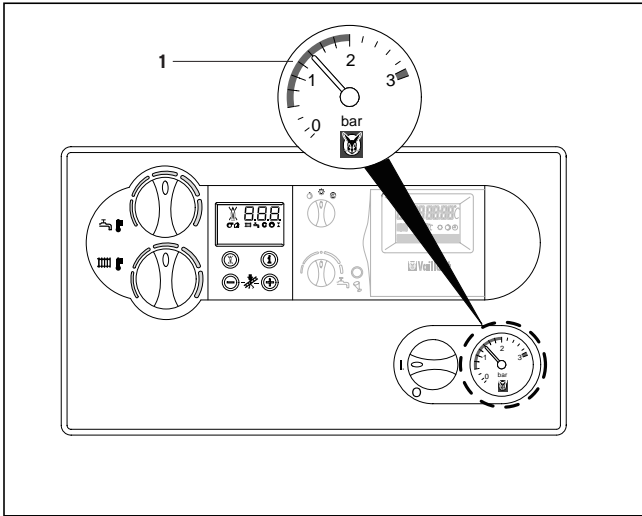

Fig. B.4 Checking the water contents

- Check the water contents of the system on the pressure gauge (1).
The needle on the pressure gauge should be within the green band (between 1 and 1.5 bar). If the needle displays a value below 0.8 bar when the appliance is cold, follow the instructions left by your installer to refill the system.
Alternatively, your installer should be called to refill the system.

4.3 Domestic hot water operation

The boiler should only be used when the heating system contains water. Use of the boiler without water may cause damage to the boiler or its components.

4.3.1 Setting the maximum domestic hot water temperature control (ecoMAX 800 series only)

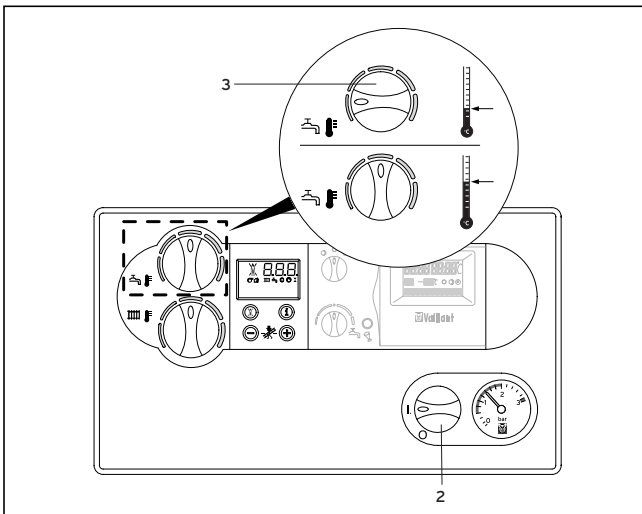

Fig. B.5 Domestic hot water operation

- Turn the main switch (2) to the "I" position.
- The display will show the boiler flow temperature which indicates electrical power to the boiler.
- The domestic hot water temperature can be adjusted using the hot water temperature control (3).
- Turn the control clockwise to increase the temperature and anti-clockwise to decrease the temperature.

Note:
This control adjusts the maximum domestic hot water temperature. If adjusting the control upwards appears to have no effect on the temperature, then the boiler is already operating at full output for the selected flow rate.

Caution!
If you live in a hard water area please do not set the control knob above the mid (12 o'clock) position to prevent excessive scale formation (fig. B.5).

4.3.2 Warmstart operation (ecoMAX 800 series only)

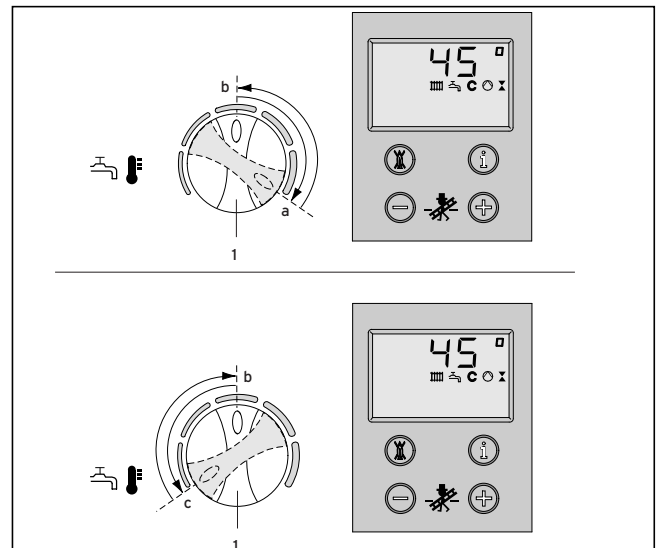

Fig. B.6 Warmstart operation (ecoMAX 800 series only)

The warmstart facility provides instantaneous delivery of domestic hot water from the boiler.

When the warmstart system is switched ON the boiler will automatically light periodically to maintain the internal temperature of the boiler. When the warmstart system is switched OFF a short delay may be experienced in obtaining hot water at the tap.

- The warmstart system is activated by turning the hot water temperature control knob (1) clockwise to position a (see fig.B.6). Now select the required temperature, e.g. setting b

An illuminated "C" symbol appears on the boiler display.

The boiler will now provide instantaneous delivery of

hot water directly when a hot water tap is turned ON.

- The warmstart system is switched OFF by turning the hot water temperature control knob (1) anticlockwise to position c. The "C" is NOT now illuminated. Reset the hot water temperature control knob to the desired setting, e.g. setting b

Note:
 Irrespective of whether the warmstart facility is switched ON or OFF, the boiler will automatically operate to provide hot water whenever a hot water tap is opened.

4.3.3 Obtaining hot water (ecoMAX 800 series only)

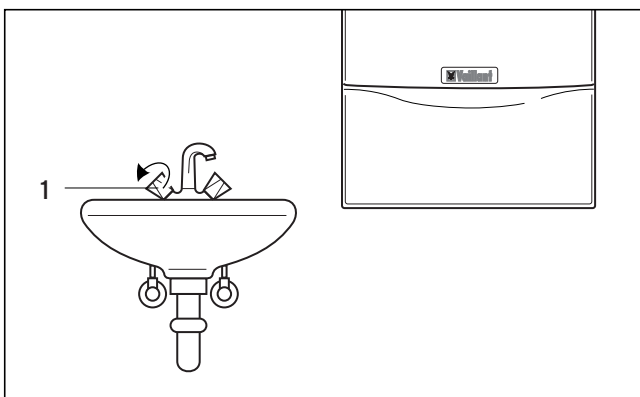

Fig. B.7 Obtaining hot water (ecoMAX 800 series only)

On opening a hot water tap (1) fig. B.7) at a supply point (basin, shower, bath, etc) the ecoMAX 800 series boiler will automatically operate to deliver hot water.

On closing the tap the boiler switches OFF (or continues to operate for central heating if required). The pump and fan will continue to operate for a short period.

4.4 Heating operation

The boiler should only be used when the heating system contains water. Use of the boiler without water may cause damage to the boiler or its components.

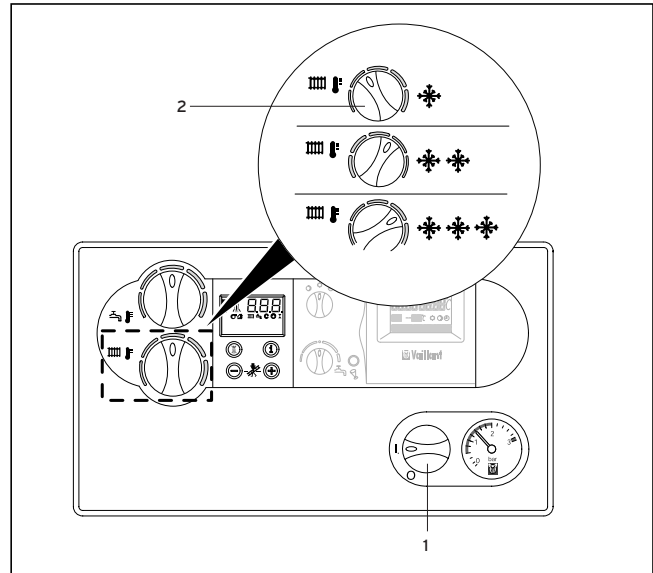

Fig. B.8 Setting the maximum radiator temperature control

4.4.1 Setting the maximum radiator temperature control

- Turn the main switch (1) to the "I" position.
- Set the maximum radiator temperature control to the desired setting using the control knob (2). We recommend the following settings:
 - Left setting during spring and autumn,
 - Middle setting during mild winter,
 - Right setting during cold winter.

When the temperature is adjusted, the boiler display will show the corresponding water temperature. This information appears on the display for about 5 seconds and then the display returns to its normal state (current heating flow temperature e.g. 45 °C).

4 Operation

4.4.2 Setting the external controls

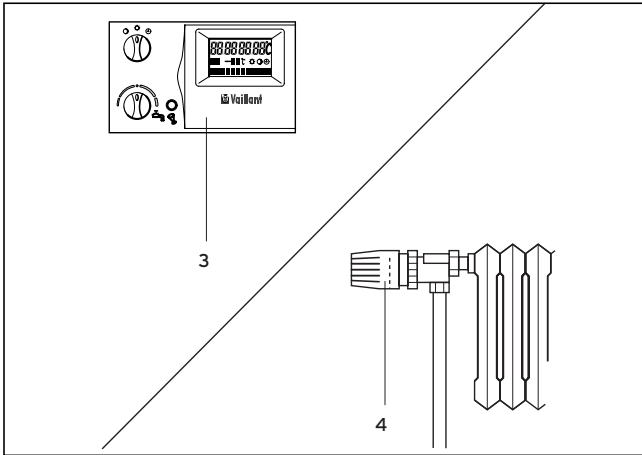

Fig. B.9 Setting the external controls

- Set the room thermostat and/or the thermostatic radiator valves according to the instructions supplied with the control(s).

Hint!
 Vaillant offer room thermostat/time control accessories which give accurate and economic room temperature control as well as improved comfort.

Ask your installer!

The boiler will now operate automatically to provide central heating for the conditions selected on the external controls (ecoMAX 800 series will also provide domestic hot water on demand).

Whilst the boiler is operating, the boiler display indicates the temperature of the water within the boiler circuit. After the boiler stops operating the pump and fan will continue to operate for a short period to fully disperse the heat from the boiler.

Note:
 The boiler incorporates an anti-cycling economiser control to prevent energy wasteful ON and OFF operation of the boiler for short periods when in the central heating mode. When turning the room thermostat to a higher setting there may therefore be a short delay before the boiler operates.

4.5 Status displays (Fig. B.10)

(for maintenance and servicing work carried out by a qualified service engineer)

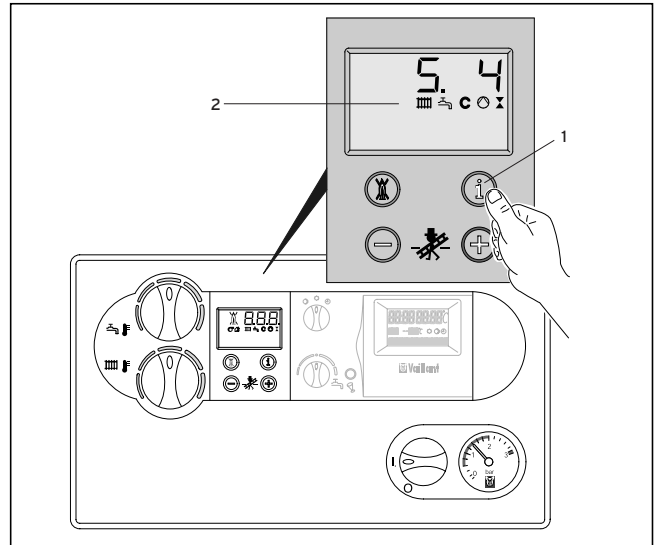

Fig. B.10 Status displays

- The status displays are activated by pressing the "i" (1) button.

The display (2) now shows the corresponding status code, e.g. "S.4" for burner operation. Please refer to table B.1 (below) for details of the most important status codes.

- Press the "i" button again to return to normal mode.

During changeover phases, such as when the system restarts after the flame has been extinguished, the "S" status message is displayed briefly.

Display	Meaning
S. 0*	No heat requirement
S. 1*	Pump running
S. 3*	Heating system ignition
S. 4*	Burner ignited
S. 5*	Fan and pump overrun
S. 7*	Pump over run
S. 8*	Anti cycling mode (after heating operation)
S. 10**	Hot-water demand
S. 14**	Burner ignited
S. 34*	Frost protection mode

Table B.1: Status displays (a complete list of status codes can be found in the installation and maintenance instructions)

- * Heating mode
- ** Hot-water mode (ecoMAX 800 series only)

4.6 Resetting the appliance

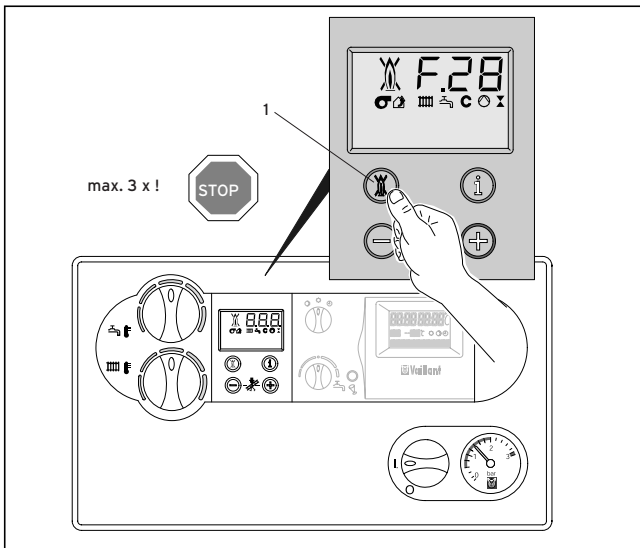

Fig. B.11 Resetting the appliance

When a hot water tap (ecoMAX 800 series only) or the central heating system requires heat, the boiler automatically ignites and starts to operate. If the automatic ignition is not successful within 5 attempts, then the boiler does not go into operation and switches to "Lock out". This is indicated by a fault code "F.28" or "F.29" on the display.

A new attempt to ignite the flame can then only be performed after pressing the "Reset" button.

- Press the "Reset" button (1) and hold for approx. 1 second.

! If the boiler still shuts off after a third attempt, then please consult your installer or Vaillant Service Solutions.

The boiler also switches to "Fault" when there is not enough water in the system. This fault is indicated by fault code "F.22" "F.23" or "F.24".

The boiler can only be placed back in operation after the heating system has been properly refilled with water.

In the unlikely event of any other fault developing, which prevents the boiler from operating, the display will also show other fault codes. If a fault code is displayed please contact your installer or Vaillant Service Solutions.

Note:
 If contacting Vaillant Service Solutions please remember to quote the fault code, as this will help to pinpoint the fault.

4 Operation

4.7 Turning the boiler OFF (ecoMAX 800 series only)

4.7.1 To turn OFF the central heating only (Summer mode)

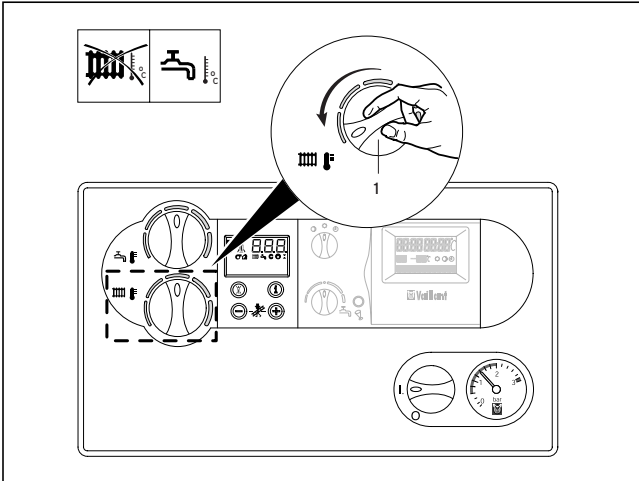

Fig. B.12 To turn OFF the central heating only (Summer mode)

- Turn the maximum radiator temperature control knob used to control the heating supply temperature (1) all the way to the left.

Hint!
You can switch off the heating operation in summer, for example, but the boiler will continue to provide domestic hot water whenever a hot water tap is opened.

4.7.2 To turn OFF central heating and hot water for short periods of time

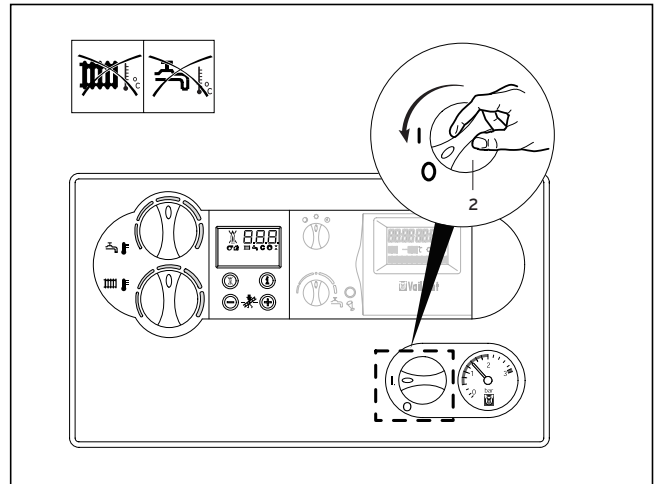

Fig. B.13 Complete shutdown

- Turn the main ON/OFF control (2) to the "0" position.

If you want to turn the ecoMAX boiler OFF for a longer period of time (e.g. holidays), and there is no danger of frost, then you should also turn off the gas supply, the cold water service valve (see page 9) and the electrical supply. Please note the frost protection hints detailed in these instructions.

4.8 Turning the boiler OFF (ecoMAX 600 series only)

4.8.1 To turn OFF the central heating

- Turn the maximum radiator temperature control knob used to control the heating supply temperature (1) all the way to the left.

Hint!
Do not turn the EcoMAX 600 boiler OFF if a hot water cylinder is also incorporated in the system unless there is no demand for domestic hot water.

4.8.2 To turn boiler OFF for short periods of time

- Turn the main ON/OFF control (2) to the "0" position.

Hint!
Do not turn the EcoMAX 600 boiler OFF if a hot water cylinder is also incorporated in the system unless there is no demand for domestic hot water.

Operation 4

4.9 Troubleshooting

In the unlikely event that a problem occurs with the operation of the ecoMAX boiler, the following points should be checked:

1 Boiler fails to operate:

- Is the gas supply turned on? (see page 9)
- Is the water supply turned on? (see page 9)
- Is there enough water in the heating system? (see page 10)
- Is the electrical supply switched ON?
- Is the main ON/OFF control in the "ON" position? (switch position "I") (see page 10)
- Is the burner lock out indicator light illuminated? (see page 13)

2 Hot water operates but no central heating (ecoMAX 800 series only)

- Is the heating turned ON? (see page 12)
- Are all external heating controls ON? (see page 12)



If your boiler still does not operate then please consult your installer or Vaillant Service Solutions (0870 6060 777).

4.10 Care and maintenance

Clean the outer casing of your boiler with a damp cloth and a little soap. Do not use abrasive or solvent cleaning agents that may damage the case or the plastic fittings. The appliance should be serviced at least once per year. To ensure regular servicing, it is strongly recommended that arrangements are made with your service agent or Vaillant Ltd.

For further details please contact Vaillant Service Solutions: (0870 6060777).

4.11 Frost protection

Your boiler is equipped with a frost protection function: If the heating water temperature drops below 5 °C when the main switch is ON, then the boiler goes into operation and heats the boiler circuit to approx. 30 °C.



It cannot be guaranteed that water will circulate throughout the entire heating system.

If the boiler is not operated for several hours during very cold weather there is therefore the possibility of the system freezing.

Please ensure that if you are absent during a period of frost the central heating remains in operation and all rooms are kept above freezing point.

It must be remembered, however, that the boiler will be automatically switched off by the built in monitoring devices if certain faults occur, e.g. interruption in the gas or electricity supply or faults in the flue gas system. To overcome this possibility you can drain both the central heating system and boiler.



Frost protection and monitoring devices can only function when the main switch of the unit is set to the "I" position and the boiler is connected to the electrical supply.

Head Office
Vaillant Ltd., Vaillant House
Medway City Estate, Trident Close,
Rochester, Kent ME2 4EZ

Service Solutions 0870 6060 777
Technical Advice 01634 292392