

For the installer

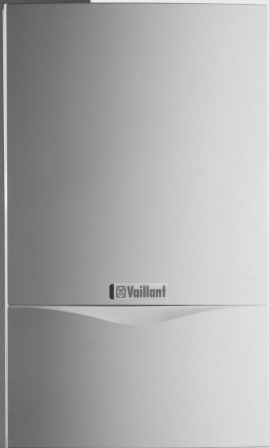

Instructions for installation and servicing ecoMAX



Wall hung room sealed fan assisted condensing boilers

ecoMAX 613/2 E
ecoMAX 618/2 E
ecoMAX 622/2 E
ecoMAX 635 E
ecoMAX 824/2 E
ecoMAX 828/2 E
ecoMAX 835 E

Table of contents

1	Introduction	4	4.14	Connection to a VANTAGE cylinder (ecoMAX 600)	21
1.1	Introduction	4	4.15	Connect the flue system to the boiler	21
1.2	General notes	4	4.16	Electrical installation	22
1.3	EC designation	4	4.16.1	General requirements	22
2	Boiler specification	5	4.16.2	Connection to the main supply	22
2.1	Technical data	6	4.16.3	Electronic board layout	23
2.2	Dimensions	6	4.16.4	Connection details for programmable thermostats	29
2.3	Boiler connections	7	4.17	Controls (ecoMAX 800)	29
2.4	Scale drawing and fitting dimensions	7	4.17.1	External electrical controls	29
2.5	Functional diagrams	8	4.17.2	Connection of external controls	29
2.6	Design	9	4.17.3	Connection details for programmable room thermostats	29
2.7	Identification plate	10	4.17.4	Connection details for time switch	30
3	General requirements	10	4.17.5	Connection details for external time switches and boiler terminal strip	31
3.1	Preliminary remarks	10	4.17.6	Vaillant optional plug in timer accessories	31
3.2	Related documents	10	4.18	Controls (ecoMAX 600)	31
3.3	Contents included with boiler (ecoMAX 800)	11	4.18.1	External electrical controls	31
3.4	Contents included with boiler (ecoMAX 600)	11	4.18.2	Connection of external electrical controls	31
3.5	Boiler location	12	4.18.3	Connection details using an external wiring centre	31
3.6	Gas supply	12	4.19	Thermostatic radiator valves	31
3.7	Flue system	12	4.20	Frost protection	31
3.7.1	Standard 100 mm flue system	12	4.21	Circulating pump	31
3.7.2	Optional 125 mm flue system (ecoMAX 635, 835)	12	4.22	Anti-cycling 'economiser' control	31
3.8	Flue termination	13	4.23	Automatic pump spin control (APS)	31
3.9	Air supply	14	5	Commissioning part I	34
3.9.1	Cupboard or compartment ventilation	14	5.1	Preliminary electrical checks	34
3.10	Electrical supply	14	5.2	Gas supply	34
3.11	Guide to system requirements	14	5.3	Cold water supply (ecoMAX 800)	34
3.11.1	Water circulation system	14	5.4	Filling the heating system (ecoMAX 800)	34
3.11.2	Filling and make up	14	5.5	Initial system flush ("Cold")	34
3.11.3	Pressure relief valve	14	5.6	Filling the heating system (ecoMAX 600)	34
3.11.4	Pressure gauge	15	5.7	Initial system flush ("Cold")	34
3.11.5	Expansion vessel	15	5.8	Filling condensate trap	34
3.12	Pump specifications	15	5.9	Adjusting pump speed	35
3.12.1	Circulating pump	15	5.9.1	ecoMAX 613/2, 618/2, 622/2, 824/2, 828/2	35
3.12.2	System by-pass	15	5.9.2	ecoMAX 635, 835	35
3.12.3	Venting	15	5.10	Checking the gas supply settings	37
3.13	Condensate trap	15	5.10.1	Factory-adjusted gas settings	37
4	Boiler installation sequence	16	5.10.2	Gas inlet working pressure	37
4.1	General	16	5.10.3	Check gas rate	37
4.1.1	Select position of boiler	16	5.11	Refitting the case	38
4.1.2	Unpack the boiler	16	5.12	Adjusting the central heating output (range rating)	38
4.1.3	Using boiler template	16	6	Functional checks (commissioning part II)	39
4.2	Rear flue exit	17	6.1	Functional checks	39
4.3	Other flue options	17	6.1.1	Procedure	39
4.4	Fitting the boiler hanging bracket	17	6.1.2	Hot-water supply (ecoMAX 800)	40
4.5	Install the flue system	17	6.1.3	Heating system	40
4.6	Fitting the boiler	18	6.1.4	Final system flush ("Hot")	40
4.7	Removing the front case	18	6.1.5	Handing over to the user	40
4.8	Cold water mains inlet and hot water outlet (ecoMAX 800)	18			
4.9	Gas supply	19			
4.10	Central heating flow and return pipework	19			
4.11	Pressure Relief Valve (ecoMAX 600)	20			
4.12	Pressure Relief Valve (ecoMAX 800)	20			
4.13	Condensate drain	21			

7	Servicing	41
7.1	Inspection and maintenance	41
7.2	Initial inspection	41
7.2.1	Removing the compact thermal module	41
7.2.2	Inspect main heat exchanger	42
7.2.3	Inspect burner	42
7.2.4	Refitting the compact thermal module	43
7.2.5	Cleaning the condensate trap	43
7.2.6	Check expansion vessel	43
7.3	Recommissioning the boiler	44
7.4	Test	44
8	Troubleshooting	44
8.1	Logical fault finding procedure	44
8.1.1	Status mode	44
8.1.2	Diagnosis mode	46
8.1.3	Fault codes	48
8.1.4	Fault memory	48
8.2	Test programs	50
9	Parts replacement	51
9.1	Safety instructions	51
9.1.1	Initial preparation	51
9.1.2	Removal of burner assembly	51
9.2	Replacement of burner	51
9.3	Replacement of fan	51
9.4	Replacement of gas valve	52
9.5	Replacement of central heating expansion vessel	52
9.6	Replacement of main heat exchanger	53
9.7	Replacement of the electronic control board	54
9.8	Check CO ₂ content and adjust if necessary (air-ratio adjustment)	54
10	Recycling and eventual scrapping	55
10.1	The appliance	55
10.2	Packing	55

1 Introduction

1 Introduction

1.1 Introduction



Note:

This boiler must be installed and serviced by a competent person in accordance with the Gas Safety (Installation and Use) Regulations 1998. In the UK 'CORGI' registered installers under take the work to a safe and satisfactory standard.

ecoMAX 800 range

The ecoMAX 800 range is a fully automatic, wall mounted, room sealed condensing (high efficiency) combination boiler for central heating and domestic hot water. Domestic hot water is supplied directly from the boiler, without requiring a copper cylinder, cold water tank, feed and expansion tank and associated pipework. Domestic hot water has priority over central heating. The ecoMAX 800 range consists of models with outputs for domestic hot water of 23 kW, 28 kW and 35 kW. All versions are available in natural gas. The 28 kW version is also available in LPG.

ecoMAX combination boilers incorporate a warmstart facility that keeps the domestic hot water heat exchanger hot, providing an instantaneous delivery of domestic hot water. The temperature in the domestic hot water heat exchanger is limited by the boiler control system and it is not necessary to install a scale reducer on the cold mains to the boiler. However, in exceptionally hard water areas to prevent scale formation in the property hot water system pipework, a scale reducer may be fitted. The heating system can be filled using the built-in filling loop contained within the boiler.

ecoMAX 600 range

The ecoMAX 600 range is a fully automatic, wall mounted, room sealed condensing (high efficiency) system boiler for central heating and domestic hot water (where a separate indirect hot water storage cylinder is also incorporated in the system). The ecoMAX 600 range consists of models with outputs of 13, 18, 22 and 35 kW. All ecoMAX 600 range boilers are available in Natural Gas. The 22 kW version is also available in LPG.

1.2 General Notes

The boilers have been designed for use with a sealed central heating system, and come fully tested and assembled with a built in circulating pump, expansion vessel and diverter valve (ecoMAX 800). The boilers are easily sited on any internal wall and can be installed with either a horizontal or vertical RSF (room sealed fan assisted) flue.

The boilers use a standard flue system (100 mm outside diameter) which allows flue lengths up to 8m (ecoMAX 828/2, 613/2, 618/2 and 622/2) 7m (ecoMAX 824/2) and 4 m (ecoMAX 635, 835). Flue extensions and additional bends and elbows are available for the flue system to increase the siting flexibility. If desired, an inhibitor may be used in the system. Guidance on the use of inhibitors is contained in these instructions.

All boilers have a built in diagnostic system which indicates the operational status of the boiler. This feature provides key information to aid commissioning and fault finding. The data badge is fitted to the underside of the boiler. See text of General Requirements for installation requirements or notes.

1.3 EC designation



ecoMAX boilers carry the 'CE' Mark. This demonstrates that the boilers fulfil the essential requirements of the Gas Appliance Directive (90/396/EEC) and the Gas Appliance (Safety) Regulations 1992.

The 'CE' Mark also demonstrates that the boilers comply with the requirements of the Electromagnetic Compatibility Directive (89/336/EEC), the Low Voltage Directive (72/23/EEC), the Boiler Efficiency Directive (92/42/EEC) and the Boiler (Efficiency) Regulations 1993.



Vaillant Ltd. support the Benchmark initiative. Within the information pack, you will find a Benchmark Log Book. It is very important that this is completed correctly at the time of installation, commissioning and handover to the user.



Boiler Specification 2

2.1 Technical data (1)

	ecoMAX 824/2 E	ecoMAX 828/2 E	ecoMAX 835 E	Units
Maximum CH heat input (G 20) (net)	18.4	22.4	27.0	kW
Maximum CH heat input (G 31) (net)	18.4	22.4	27.0	kW
CH heat output range				
80 °C flow/60 °C return	11.0 - 18.4	13.4 - 22.4	10.5 - 27.0	kW
50 °C flow/30 °C return	11.6 - 19.4	14.1 - 23.6	11.0 - 28.4	kW
SEDBUK	A	A	A	Band
SAP Seasonal Efficiency	91.1	91.1	91.1	%
Maximum DHW heat input (net)	23.0	28.0	35.0	kW
Maximum DHW output	23.0	28.0	35.0	kW
DHW flow rate $\Delta T = 35$ K rise	9.4	11.5	14.3	l/min
Appr. DHW flow rate at factory set temp. rise (DT = 42 °C)	7.9	9.6	11.9	l/min
Mains water pressure required for max. flow rate	0.5	0.5	0.5	bar
Minimum water flow rate	1.5	1.5	1.5	l/min
Mains water pressure required for min. flow rate	0.2	0.2	0.2	bar
Maximum inlet water pressure	10	10	10	bar
Inlet gas working pressure required (natural gas)	20	20	20	mbar
Inlet gas working pressure required (Propane)	37	37	37	mbar
Gas supply (G20) Gross CV (s.t.)	37.8	37.8	37.8	MJ/m ³
Gas supply (G31) Gross CV (s.t.)	95.65	95.65	95.65	MJ/m ³
Gas rate (natural gas) max.	2.43	2.96	3.7	m ³ /h
Gas rate (Propane) max.	1.78	2.18	2.7	kg/h
CH temperature flow range	30 - 85	30 - 85	30 - 85	°C
Minimum CH water flow (for 20 °C rise)	790	960	1160	l/h
Pump pressure available	0.25	0.25	0.25	bar
10 l expansion vessel pre-charge pressure	0.75	0.75	0.75	bar
Maximum CH system pressure	2.5	2.5	2.5	bar
Connections heating flow/return	22	22	22	mm
Gas inlet	15	15	15	mm
Pressure relief discharge pipework (min.)	15	15	15	mm
Condensate drain (min. internal drain)	19	19	19	mm
Weight	40	41	48	kg
Primary water content	1.8	2.0	2.4	l
Volume of condensate (max.)	2.1	2.5	3.3	l/h
Maximum flue gas temperature	70	70	70	°C
Electrical supply voltage	230/50	230/50	230/50	V ~/Hz
Internal fuse (slow) main voltage	4	4	4	A
Internal fuse (slow) low voltage	4	4	4	A
Power input	115	115	140	W

2 Boiler Specification

2.1 Technical data (2)

ecoMAX	613/2 E	618/2 E	622/2 E	635 E	Units
Maximum CH heat input (G 20) (net)	13.5	18.4	22.4	34.9	kW
Maximum CH heat input (G 31) (net)	13.5	18.4	22.4	34.9	kW
CH heat output range					
80 °C flow/60 °C return	4.6 - 13.5	11.0 - 18.4	13.4 - 22.4	10.5 - 34.9	kW
50 °C flow/30 °C return	4.8 - 14.2	11.6 - 19.4	14.1 - 23.6	11.0 - 36.7	kW
SEDBUK	A	A	A	A	Band
SAP Seasonal Efficiency	91.2	91.2	91.2	91.2	%
Inlet gas working pressure required (natural gas)	20	20	20	20	mbar
Inlet gas working pressure required (Propane)	37	37	37	37	mbar
Gas supply (G20) Gross CV (s.t.)	37.8	37.8	37.8	37.8	MJ/m ³
Gas supply (G31) Gross CV (s.t.)	95.65	95.65	95.65	95.65	MJ/m ³
Gas rate (natural gas) max.	1.43	1.95	2.37	3.7	m ³ /h
Gas rate (Propane) max.	1.05	1.43	1.74	2.7	kg/h
CH temperature flow range	30 - 85	30 - 85	30 - 85	30 - 85	°C
Minimum CH water flow (for 20 °C rise)	580	790	960	1480	l/h
Pump pressure available	0.25	0.25	0.25	0.25	bar
10l expansion vessel pre-charge pressure	0.75	0.75	0.75	0.75	bar
Maximum CH system pressure	2.5	2.5	2.5	2.5	bar
Connections heating flow/return	22	22	22	22	mm
Gas inlet	15	15	15	15	mm
Pressure relief discharge pipework (min.)	15	15	15	15	mm
Condensate drain (min. internal drain)	19	19	19	19	mm
Weight	39	39	40	41	kg
Primary water content	1.8	1.8	2.0	2,2	l
Volume of condensate (max.)	1.2	2.1	2.5	3,3	l/h
Maximum flue gas temperature	70	70	70	70	°C
Electrical supply voltage	230/50	230/50	230/50	230/50	V ~/Hz
Internal fuse (slow) main voltage	4	4	4	4	A
Internal fuse (slow) low voltage	4	4	4	4	A
Power input	115	115	115	115	W

2.2 Dimensions

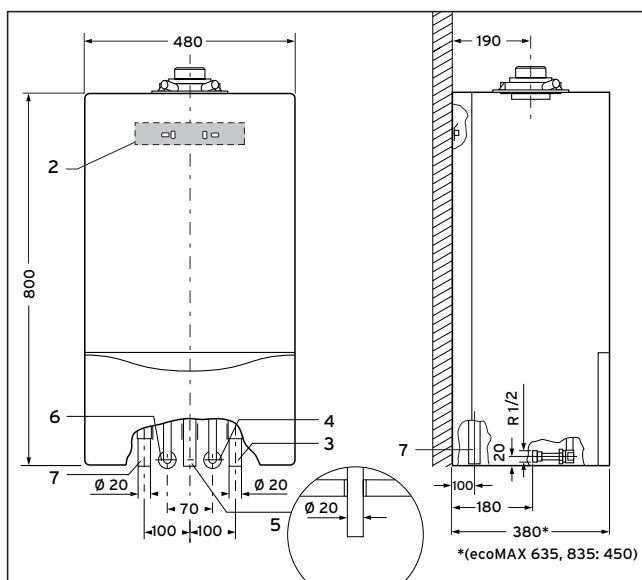

Fig. 2.1

- 2 Hanging bracket
- 3 Heating-system return
- 4 Cold-water inlet (ecoMAX 800/2 only)
- 5 Gas connection
- 6 Hot-water outlet (ecoMAX 800/2 only)
- 7 Heating-system flow

2.3 Boiler connections

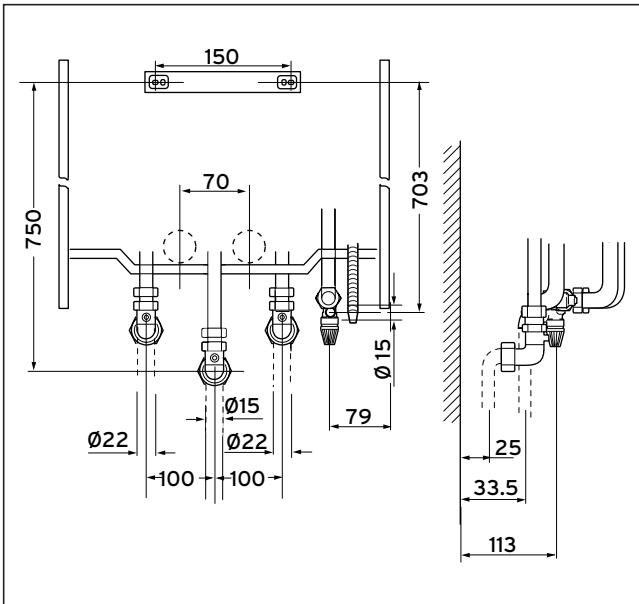

Fig. 2.2

2.4 Scale drawing and fitting dimensions

Dimensions when combined with the following system comp.:	A with 87° elbow	ØB	C*
air/flue system Ø 60/100	235	60/100	-
air/flue system Ø 80/125	253	80/125	-
VANTAGE 120	-	-	1101
VANTAGE 150	-	-	1101
VANTAGE 200	-	-	-

Tab. 2.1 Dimensions used in combinations

*) Note: Dimension C must be observed if a Vaillant VANTAGE 120, 150 and 200 hot-water tank is to be installed under the heating unit.

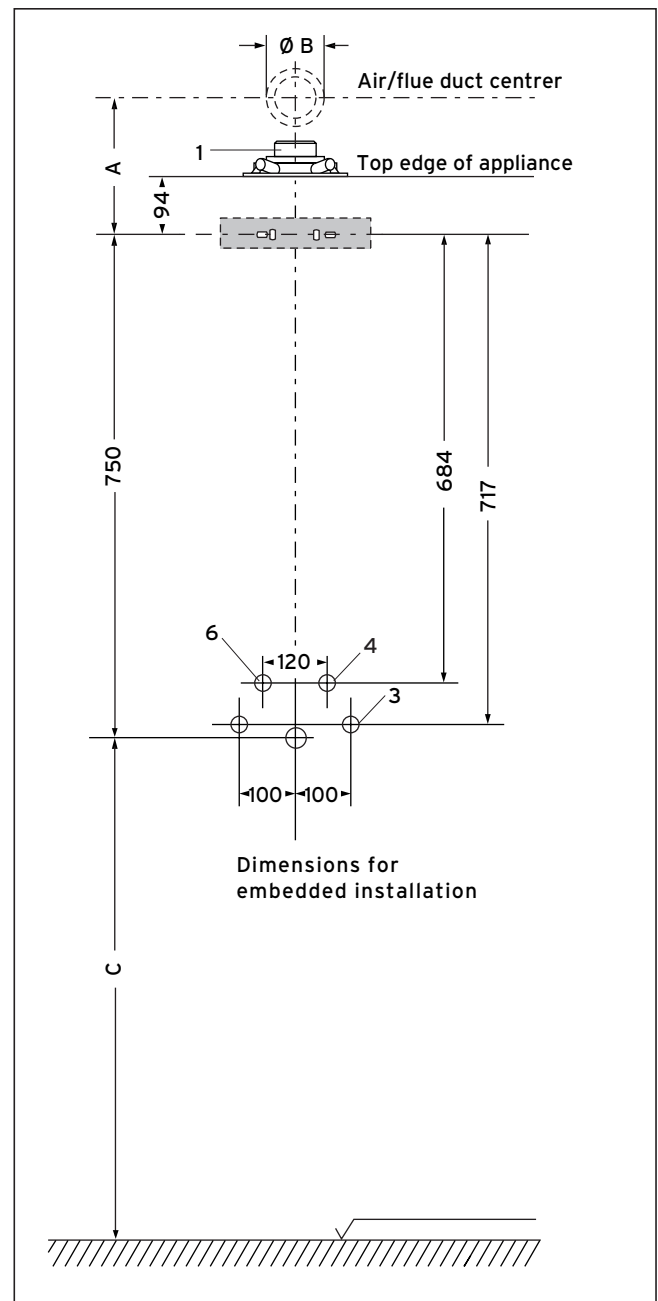

Fig. 2.3 Fitting dimensions

2 Boiler Specification

2.5 Functional diagrams

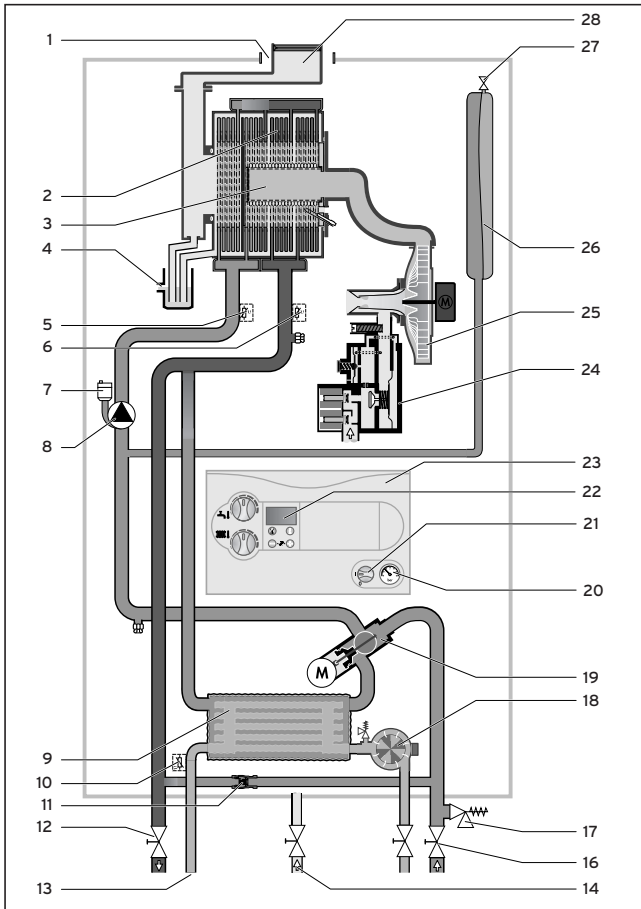

Fig. 2.4 Functional diagram ecoMAX 800/2, 835

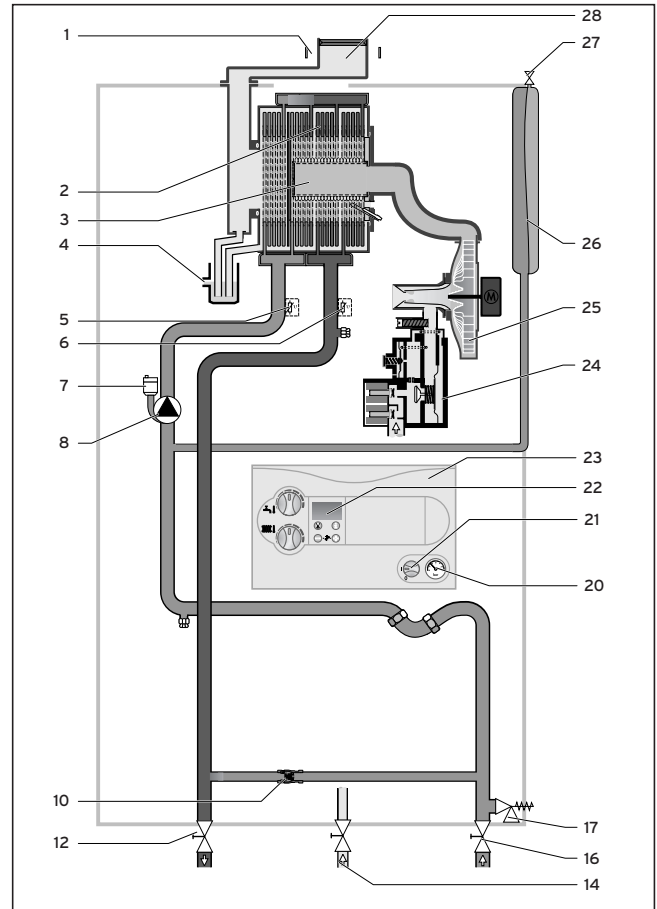

Fig. 2.5 Functional diagram ecoMAX 600/2, 635

- 1 Air duct
- 2 Main heat exchanger
- 3 Burner
- 4 Condensate trap
- 5 Temperature sensor (NTC 1)
- 6 Temperature sensor (NTC 2)
- 7 Automatic air vent
- 8 Circulating pump
- 9 DHW heat exchanger
- 10 Temperature sensor (NTC 3)
- 11 Automatic bypass valve
- 12 CH flow service valve
- 13 Domestic hot water outlet
- 14 Gas service valve
- 15 Cold water inlet
- 16 CH return service valve
- 17 Pressure relief valve
- 18 Aqua sensor
- 19 Diverter valve
- 20 Pressure gauge
- 21 Main ON/OFF control
- 22 Boiler display
- 23 Electronic box
- 24 Gas valve
- 25 Fan
- 26 Expansion vessel
- 27 Expansion vessel charging valve
- 28 Flue gas duct

- 1 Air duct
- 2 Main heat exchanger
- 3 Burner
- 4 Condensate trap
- 5 Temperature sensor (NTC 1)
- 6 Temperature sensor (NTC 2)
- 7 Automatic air vent
- 8 Circulating pump
- 10 Automatic bypass valve
- 12 CH flow service valve
- 14 Gas service valve
- 16 CH return service valve
- 17 Pressure relief valve
- 20 Pressure gauge
- 21 Main ON/OFF control
- 22 Boiler display
- 23 Electronic box
- 24 Gas valve
- 25 Fan
- 26 Expansion vessel
- 27 Expansion vessel charging valve
- 28 Flue gas duct

2.6 Design

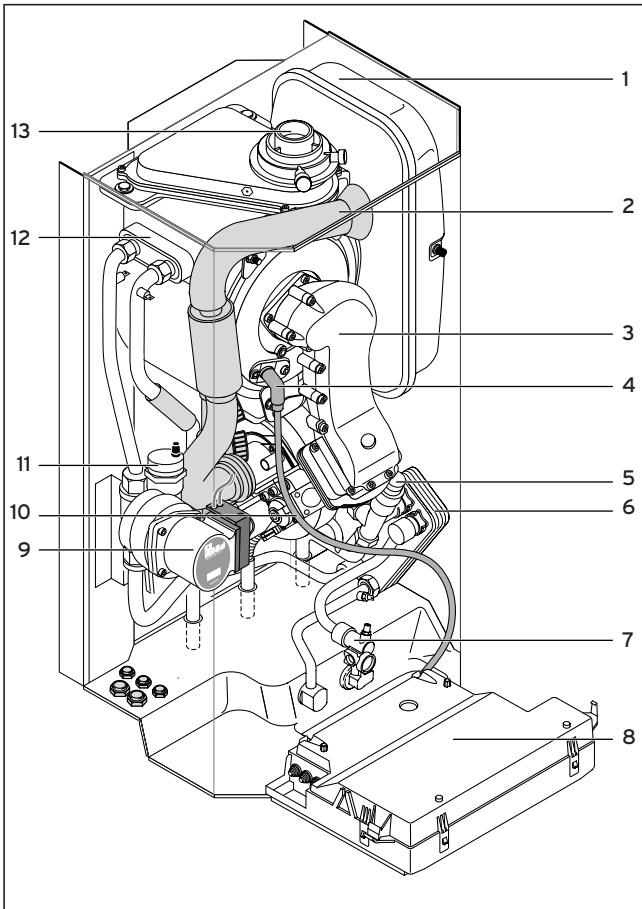

Fig. 2.6 Functioning elements, ecoMAX 800/2 configuration

- 1 Expansion vessel
- 2 Air suction pipe
- 3 Burner assembly
- 4 Ignition electrode
- 5 Diverter valve
- 6 DHW heat exchanger
- 7 Aqua sensor
- 8 Electronic box
- 9 Circulating pump
- 10 Gas valve assembly
- 11 Auto air vent
- 12 Main Heat exchanger
- 13 Air/flue gas duct

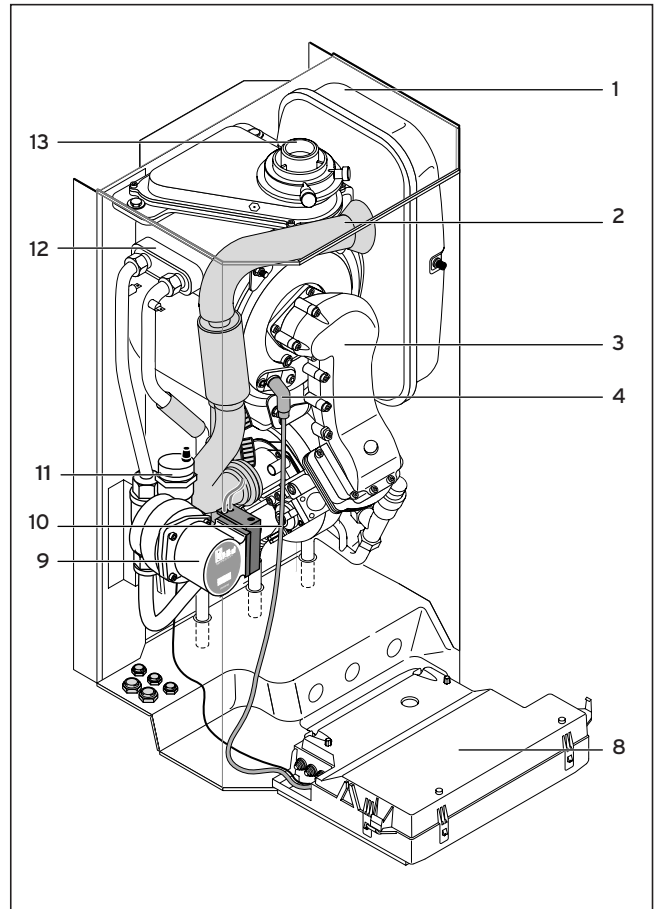

Fig. 2.7 Functioning elements, ecoMAX 600/2 configuration

- 1 Expansion vessel
- 2 Air suction pipe
- 3 Burner assembly
- 4 Ignition electrode
- 8 Electronic box
- 9 Circulating pump
- 10 Gas valve assembly
- 11 Auto air vent
- 12 Main Heat exchanger
- 13 Air/flue gas duct

2 Boiler Specification

3 General requirements

2.7 Identification plate

The identification plate of the Vaillant ecoMAX is supplied ready-attached to the bottom of the unit.

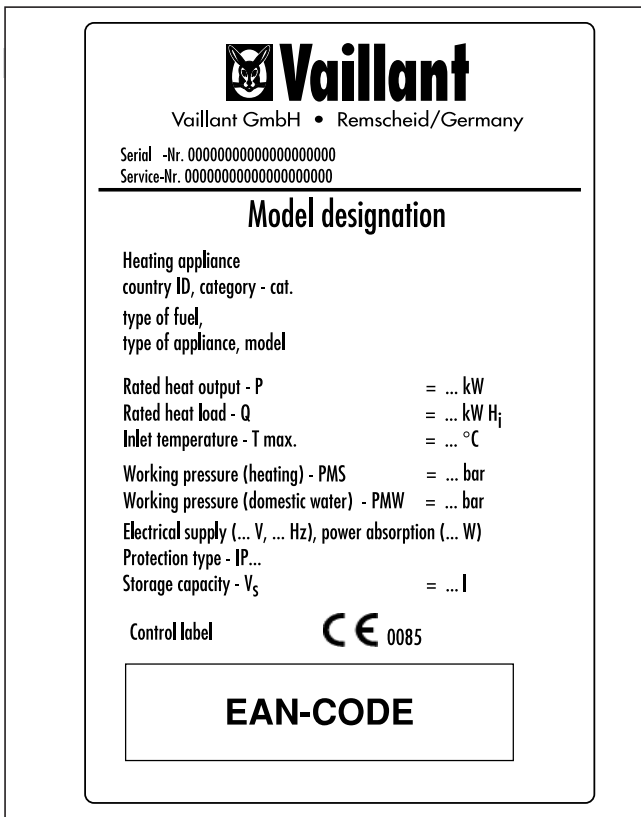

Fig. 2.8 Identification plate (example)

3 General requirements

3.1 Preliminary remarks

This appliance should only be installed in conjunction with a Vaillant flue system. Install the flue system as detailed in the separate flue installation instructions supplied with this boiler.

3.2 Related documents

The installation of the boiler must be in accordance with the relevant requirements of Gas Safety (Installation and Use) Regulations 1998, Health and Safety Document No. 635 (The Electricity at Work Regulations 1989), BS7671 (IEE Wiring Regulations) and the Water Supply (Water Fitting) Regulations 1999, or The Water Bylaws 2000 (Scotland). It should also be in accordance with the relevant requirements of the Local Authority, Building Regulations, including amendments to the Approved Documents Part L and J 2002, The Building Regulations (Scotland). The Building Regulations (Northern Ireland) and the relevant recommendations of the following British Standards:

BS 5440: Flues and ventilation of gas fired boilers not exceeding 70 kW net:

- Part 1: Flues
- Part 2: Ventilation

BS 5449: Specification for forced circulation hot water for domestic premises.

BS 5546: Specification for gas hot water supplies for domestic premises.

BS 6700: Services supplying water for domestic use within buildings and their curtilages.

BS 6798: Specification for installation of gas fired boilers not exceeding 60 kW input.

BS 6891: Specification for installation of low pressure gas pipework up to 28 mm (R1) in domestic premises (2nd family gas).

BS 7593: Treatment of water in domestic hot water central heating systems.

Institute of Gas Engineers Publication IGE/UP/7/1998: "Guide for gas installations in timber framed housing"



Important:

The appliance must be installed and serviced by a Competent Person as stated in the Gas Safety (Installation and Use) Regulations 1998. In IE, the installation must be in accordance with the current edition of I.S.813 'Domestic Gas Installations', the current Building Regulations and reference should be made to the current ETCI rules for electrical installation.



Important:

When tightening or loosening screwed connections always use suitable open-ended spanners (not pipe wrench, or extensions, etc.). Incorrect use and/or unsuitable tools can lead to damage being caused (e.g. gas or water leakage)!

3.3 Contents included with boiler (ecoMAX 800/2)

Ensure that all contents are included before commencing installation.

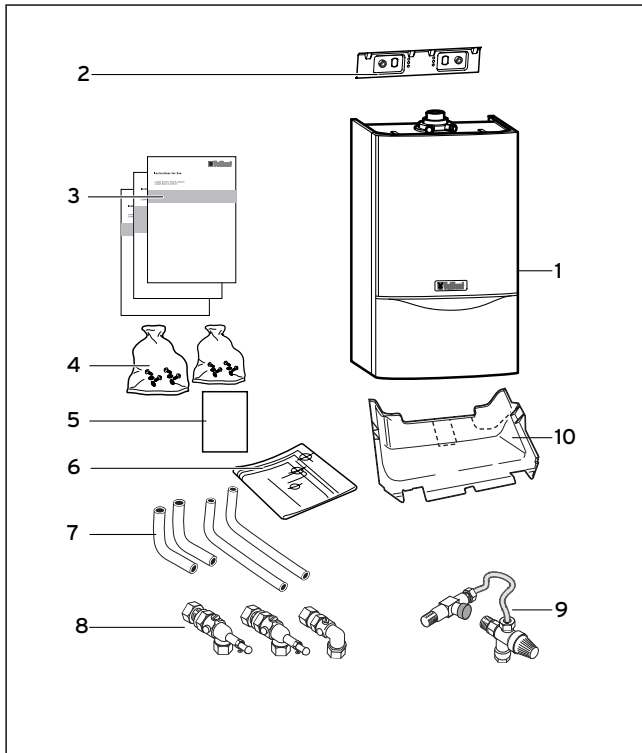

Fig. 3.1 Items supplied with unit (ecoMAX 800)

3.4 Contents included with boiler (ecoMAX 600/2)

Ensure that all contents are included before commencing installation.

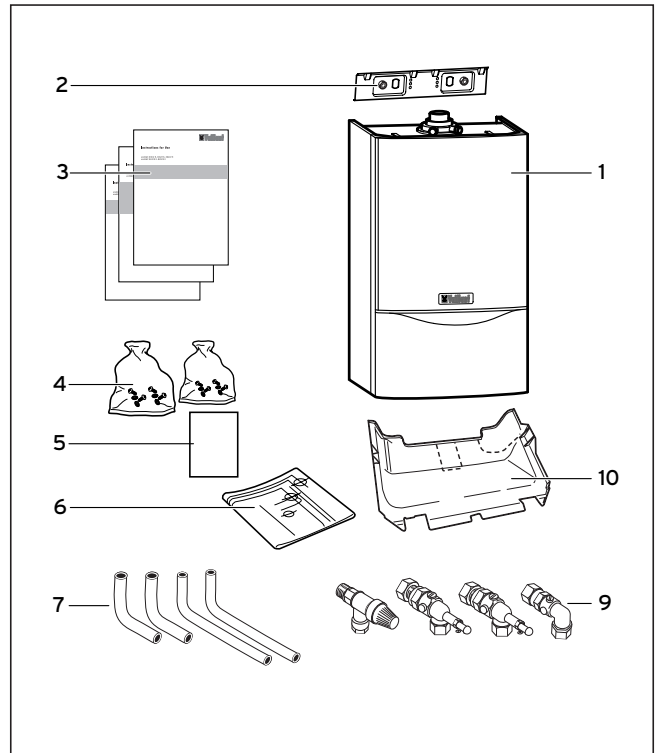

Fig. 3.2 Items supplied with unit (ecoMAX 600)

DO NOT remove the boiler from the polystyrene base at this stage.

Item	Quantity	Description
1	1	Boiler
2	1	Hanging bracket
3	3	Installation and Servicing, Users and Flue Installation Instructions
4	1	Installation and connection accessories
5	2	Guarantee Card and Benchmark log book
6	1	Template
7	4	Copper tails for gas and water pipework
8	3	Flow and return service valve, gas service valve
9	1	Pressure relief valve/double check valve
10	1	Lower cover (packed inside boiler)

Table 3.1 Items supplied with unit (ecoMAX 800)

DO NOT remove the boiler from the polystyrene base at this stage.

Item	Quantity	Description
1	1	Boiler
2	1	Hanging bracket
3	3	Installation and Servicing, Users and Flue Installation Instructions
4	1	Installation and connection accessories
5	2	Guarantee Card and Benchmark log book
6	1	Template
7	4	Copper tails for gas and water pipework
8	3	Flow and return service valve, gas service valve
9	1	Pressure relief valve
10	1	Lower cover (packed inside boiler)

Table 3.2 Items supplied with unit (ecoMAX 600)

3 General requirements

3.5 Boiler location

The location chosen for the boiler must permit the provision of a satisfactory flue termination. The location must also provide adequate space for servicing and air circulation around the boiler. The boiler may be installed in any room, although particular attention is drawn to the requirements of BS7671 (IEE Regulations), the electrical provisions of the Building Standards (Scotland) Regulations, and in IE the current edition of IS813 and the current ETCI rules, in respect of the installation of a boiler in a room containing a bath or shower.

Note:
Where a room sealed boiler is installed in a room containing a bath or shower, any electrical switch or boiler control utilising mains electricity should be so situated that it cannot be touched by a person using the bath or shower.

Where the installation of the boiler will be in an unusual location, special procedures may be necessary and BS 5546 and BS 6798 give detailed guidance on this aspect. The boiler must be mounted on a flat, vertical wall, which must be sufficiently robust to take the weight of the boiler. The boiler may be installed on a combustible wall, subject to the requirements of the Local Authorities and Building Regulations.

A compartment used to enclose the boiler must be designed and constructed specifically for this purpose. (An existing cupboard or compartment may be used provided that it is modified for the purpose). Details of essential features of cupboard/compartment design including airing cupboard installations are given in BS 6798. If the boiler is to be fitted in a timber framed building, it should be fitted in accordance with Institute of Gas Engineers Publication IGE/UP/7/1998 "Guide for Gas Installation in Timber Framed Housing".

3.6 Gas supply

The gas supplier should ensure the availability of an adequate supply of gas. A gas meter may only be connected to the service pipe by the supplier of gas or their contractor. An existing meter should be checked to ensure that it is capable of passing the rate of gas supply required.

Installation pipes should be fitted in accordance with BS 6891. In IE the current edition of IS 813. Pipework from the meter to the boiler must be of an adequate size. Do not use pipes of a smaller size than the boiler gas connection (15 mm). The complete installation must be tested for soundness and purged as described in BS 6891.

3.7 Flue system

3.7.1 Standard 100mm flue system

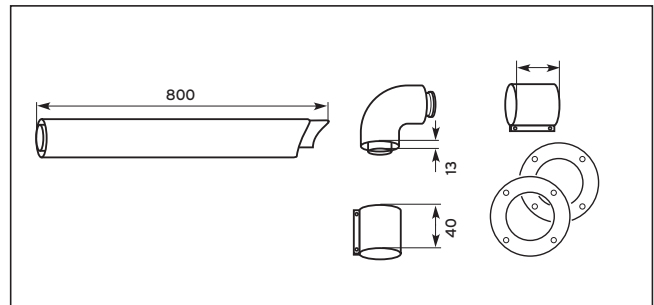

Fig. 3.3 Art.-No. 303 930

The standard 100 mm flue system (Art. No. 303 930) is suitable for installations up to 740 mm measured from the centre of the boiler flue outlet to the outside face of the wall.

Flue extensions are available to extend this length up to 8 m for ecoMAX 828/2, 613/2, 618/2 and 622/2, 7 m for ecoMAX 824/2 and 4 m for ecoMAX 635, 835. Both 90° bends and 45° elbows are also available to increase siting flexibility.

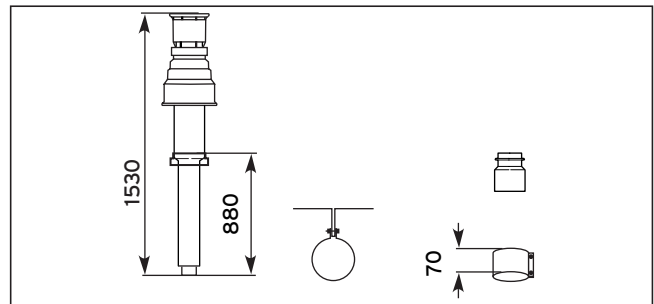

Fig. 3.4 Art.-No. 303 900

3.7.2 Optional 125 mm flue system

A concentric flue system of 125 mm outside diameter is available and can be used to achieve flue lengths up to 13 m for ecoMAX 613/2, 25 m for ecoMAX 618/2, 824/2, 30 m for ecoMAX 622/2 and 828/2 and 21 m for ecoMAX 635, 835. A vertical flue system is also available. Refer to flue system installation instructions for full details.

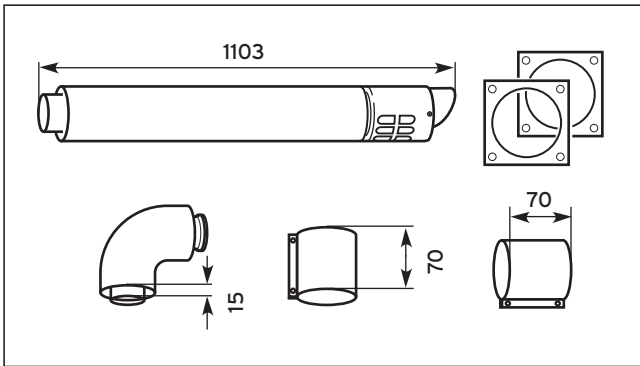

Fig. 3.5 Art.-No. 303 209

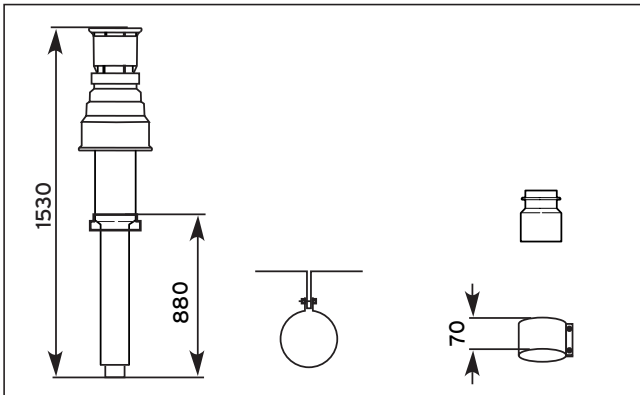

Fig. 3.6 Art.-No. 303 200

3.8 Flue termination

The following details refer to both flue systems.

- a. The terminal must be positioned such that the products of combustion can disperse freely at all times.
- b. A plume of water vapour will sometimes be visible from the flue terminal. Positions where this could be a nuisance should be avoided.
- c. If the terminal is fitted less than 2 m above a balcony, above ground or above a flat roof to which people have access then a suitable terminal guard must be provided and fitted (made by Tower Flue Components, Tonbridge, TN9 1TB).

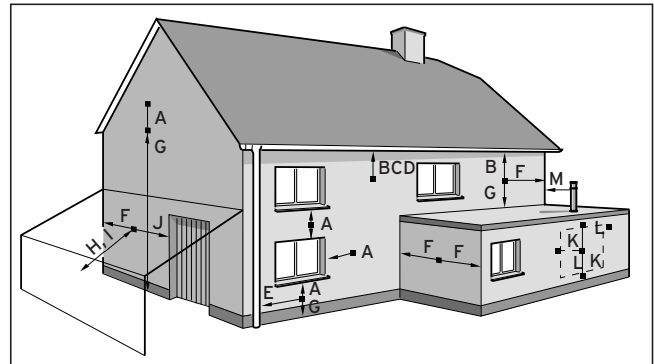

Fig. 3.7 Flue termination

Note:
 Vertical flues must not terminate within 600 mm of an openable window, air vent or any other ventilation opening.

The flue assembly shall be so placed or shielded as to prevent ignition or damage to any part of the building.

Terminal position	mm
A Directly below an opening, above an opening or horizontal to an opening, air brick, opening window, etc.	300
B Below gutters, soil pipes or drain pipes	75
C Below eaves	200
D Below balconies	200
E From vertical drain pipes and soil pipes	25
F From internal or external corners	300
G Above ground, roof or balcony	300
H From a surface facing a terminal	600
I From a terminal facing a terminal	1200
K Vertically from a terminal on the same wall	1500
L Horizontally from a terminal on the same wall	300
M Distance from adjacent for vertical Flue	500

Table 3.3 Terminal position for a fan assisted concentric flue

3 General requirements



Note:

In addition, the terminal should not be nearer than 150 mm to an opening in the building fabric formed for the purpose of accommodating a built-in element such as a window.

BS 5440-1 It is recommended that the fanned flue terminal should be positioned as follows:

- a) at least 2m from an opening in the building directly opposite, and
- b) so that the products of combustion are not directly directed to discharge across a boundary.

1) Dimensions B, C and D:

These clearances may be reduced to 25 mm without affecting the performance of the boiler. In order to ensure that the condensate plume does not affect adjacent surfaces the terminal should be extended as shown in fig. 3.8.

2) Dimension F:

This clearance may be reduced to 25 mm without affecting the performance of the boiler. However, in order to ensure that the condensate plume does not affect adjacent surfaces a clearance of 300 mm is preferred. For IE, recommendations are given in the current edition of IS 813.

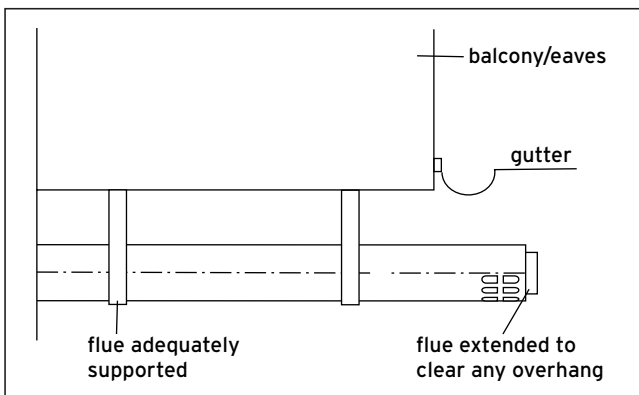

Fig. 3.8

3.9 Air supply

Detailed recommendations for air supply are given in BS 5440: Part 2.

It is not necessary to have an air vent in the room or internal space in which the boiler is installed.

3.9.1 Cupboard or compartment ventilation

The boilers are very high efficiency appliances. As a consequence the heat loss from the appliance casing during operation is very low. For cupboard or compartment installations it is therefore not necessary to provide any high or low level permanent air vents for cooling purposes.

3.10 Electrical supply

A 230 V, ~ 50 Hz single phase electricity supply fused to 3 Amp. must be provided in accordance with the latest

edition of BS7671 (IEE Wiring Regulations) and any other local regulations that may apply. In IE reference should be made to the current edition of the ETCI rules. The method of connection to the mains electricity supply must provide a means of completely isolating the boiler and its ancillary controls. Isolation is preferably by the use of a fused three pin plug and unswitched shuttered socket outlet, both complying with the requirements of BS 1363. Alternatively, a 3 Amp. fused doublepole switch with a 3 mm contact separation on both poles may be used.

This appliance must be earthed.

3.11 Guide to system requirements

3.11.1 Water circulation system

Detailed recommendations for the water circulation system are given in BS 6798 and BS 5449: Part 1 (for small bore and micro bore central heating systems). Pipework not forming part of the useful heating surface should be insulated to help prevent heat loss and possible freezing, particularly where pipes are run through roof spaces and ventilated underfloor spaces. Draining taps must be located in accessible positions which permit the draining of the whole system including the boiler and the hot water system. Draining taps should be at least 1/2 in. BSP nominal size and be in accordance with BS 2879. The boiler is suitable for use with minibore or microbore systems. Copper tubing to BS 2871: Part 1 should be used for water carrying pipework. All capillary joints in all DHW pipework must be made with lead free solder. Particularly where a new boiler is to be fitted to an existing system, it is good practice that the system is thoroughly cleansed. This cleansing should take place prior to the fitting of the new boiler and be in accordance with BS 7593. For advice on the application of system cleansers contact Sentinel, Betz Dearborn Ltd. Widnes, Cheshire, WA8 8UD. Tel: 0151 495 1861, or Fernox, Alpha Fry Technologies, Tandem House, Marlow Way, Croydon, CR0 4XS. Tel 0870 6015000

3.11.2 Filling and make up

The system can be filled using the built in filling loop (ecoMAX 800) or via a separate filling point fitted at a convenient position on the heating circuit. The connection must be removed when filling is completed. Where local Water Authority regulation does not allow temporary connection, a sealed system filler pump with break tank must be used. The heating system will not be filled automatically from the domestic hot water side. (Alternative methods of filling sealed systems are given in BS 5449).

3.11.3 Pressure relief valve

A pressure relief valve is provided with the boiler. This safety device is required on all sealed C.H. systems and is preset at 3 bar and provided with a 15 mm compression connection for a discharge pipe, which must be of no less than 15 mm in diameter. The pressure relief valve must not be used for draining purposes.

3.11.4 Pressure gauge

This is factory fitted to the boiler and indicates the primary circuit pressure to facilitate filling and testing.

3.11.5 Expansion vessel

ecoMAX boilers incorporate a 10 litre expansion vessel which is suitable for a sealed heating system with a maximum water content of 100 litres.

If the nominal capacity of the built in expansion vessel is not sufficient for the heating system (for instance in case of modernization of old open systems) an additional expansion vessel can be installed external to the boiler. It should be fitted in the return pipe as close as possible to the boiler in accordance with BS 5449: Part 1. Guidance on the sizing of an additional expansion vessel is given in Table 3.4.

	Vessel	Volume [L]
Initial system pressure (bar)	1.0	1.5
Pressure relief valve setting (bar)	3.0	
Total water content of system litres		
25	2.7	3.9
50	5.4	7.8
100	10.9	15.6
125	13.6	19.5
150	16.3	23.4
175	19.1	27.3
200	21.8	31.2
225	24.5	35.1
250	27.2	39.0
275	30.0	42.9
300	32.7	46.8
325	35.7	50.7
350	38.1	54.6
375	40.9	58.5
400	43.6	62.4
425	46.3	66.3
450	49.0	70.2
475	51.8	74.1
500	54.5	78.0
For system volumes other than those given above, multiply the system volume by the factor across	0.109	0.156

Table 3.4 Sizing of additional expansion vessel

3.12 Pump specifications

3.12.1 Circulating pump

The circulating pump is included in the boiler. The pump head available for the heating system is shown in fig. 3.9. Circulating pump (ecoMAX 635 and 835 only):

The ecoMAX 635 and 835 boilers are fitted with a modulating circulating pump. The pump head available for the heating system is shown in figure 3.10.

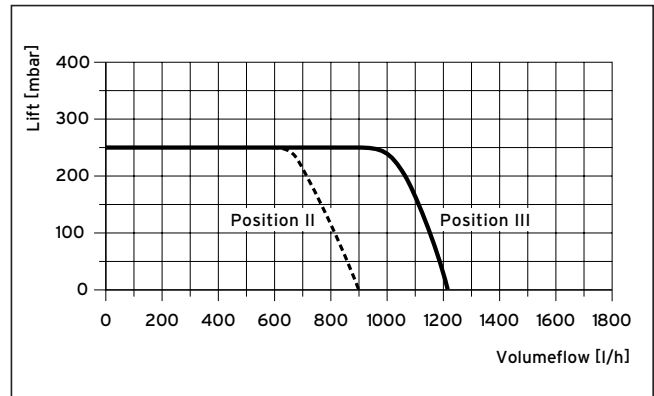

Fig. 3.9 Pump specifications ecoMAX 613/2, 618/2, 622/2, 824/2, 828/2

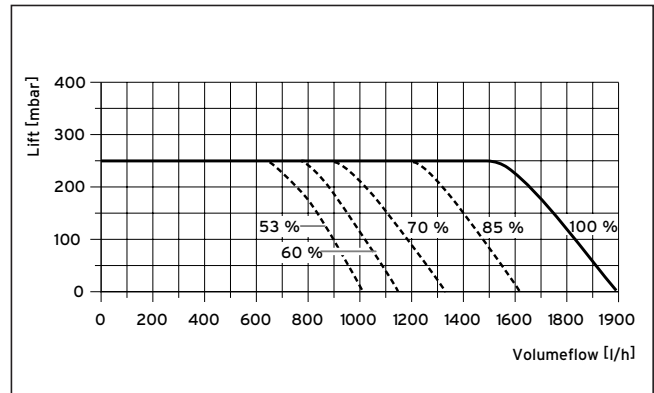

Fig. 3.10 Pump specifications ecoMAX 635, 835

3.12.2 System by-pass

An automatic system by-pass is included within the boiler. The boiler is suitable for use in systems with thermostatic radiator valves and no additional by-pass is required.

3.12.3 Venting

The boiler is fitted with an automatic air vent. Additional provision should be made to enable the heating system to be vented during filling and commissioning either by automatic air vents or manually.

3.13 Condensate trap

The boiler is fitted with a condensate trap incorporating a water trap of 75 mm.

4 Boiler installation sequence

4 Boiler installation sequence

4.1 General

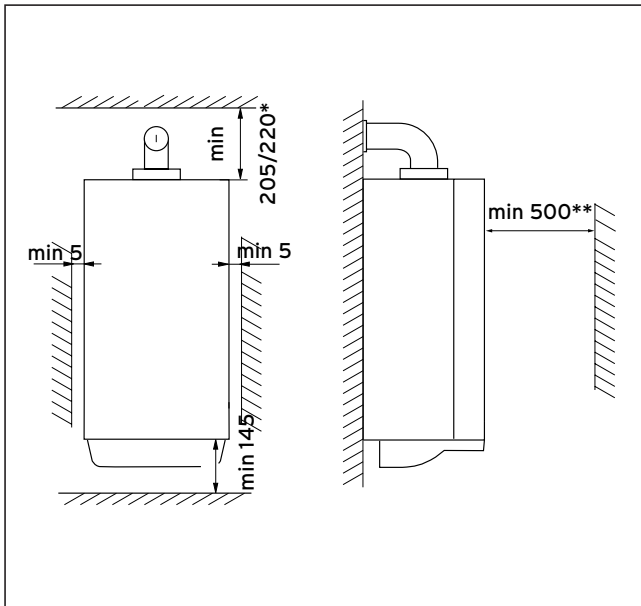

Fig. 4.1

The boiler should be mounted on a flat and vertical area of wall of sufficient area for the boiler plus the required clearances for installation and servicing (fig. 3.8). These are shown on the installation template supplied with the boiler and are:

- 5 mm either side of the boiler
- 145 mm below the boiler
- 205 mm* above the boiler when utilising the 100 mm outside diameter flue
- 220 mm* above the boiler when utilising the 125 mm outside diameter flue
- 500 mm in front of the boiler**

Note:
If the boiler is to be fitted in a timber framed building, it should be fitted in accordance with British Gas publication DM2 'Guide for gas installations in timber framed housing'.

4.1.1 Select position of boiler

Refer to section 'Boiler location' for information regarding siting the appliance. In general the boiler must be positioned such that:

- There is adequate space around the boiler for service and maintenance
- The boiler can be correctly flued, i.e. the flue terminal position is sited in accordance with these instructions and the air/flue duct can be installed in accordance with the flue installation instructions supplied.
- All necessary pipework can be connected, including the pressure relief valve and condensate drain.

4.1.2 Unpack the boiler

To unpack the boiler, cut both plastic carton straps, open box and lift out the polystyrene top packing. Lift the cardboard box upwards.

Note:
Care should be taken not to scratch the white surface of the boiler casing.

Packed in the boiler carton are the following:

- Boiler
- Flow and return central heating service valves
- Gas service valve
- Pressure relief valve and double check valve (ecoMAX 800)
- Pre-formed copper pipework (for central heating flow and return, gas and pressure relief valve connections)
- Boiler installation template
- Boiler hanging bracket
- Fixing screws, wall plugs and washers
- Installation and user instructions
- Flue installation instructions
- Guarantee card, envelope and Benchmark log book.

4.1.3 Using boiler template

Fix the paper template to the wall ensure that the template is vertical.

The template shows:

- The position of the fixing holes for the boiler mounting bracket (1).
- The position of the connections.
- The position of the flue exit hole.

Mark the position of the hanging bracket fixing holes (1). Drill 2 holes \varnothing 8 mm for the hanging bracket.

Note:
Use alternative fixing holes where necessary.

** This clearance is only required to enable easier access to the boiler for servicing and may be provided by an openable door, etc.

4.2 Rear flue exit

Mark the position of the air/flue duct and its circumference.

4.3 Other flue options

Flue instructions for other flue systems such as vertical RSF flues, flues run to the side of the boiler and the use of additional bends etc. are detailed in the flue installation instructions provided with the boiler. Remove the template from the wall and plug the drilled holes using the wallplugs supplied.

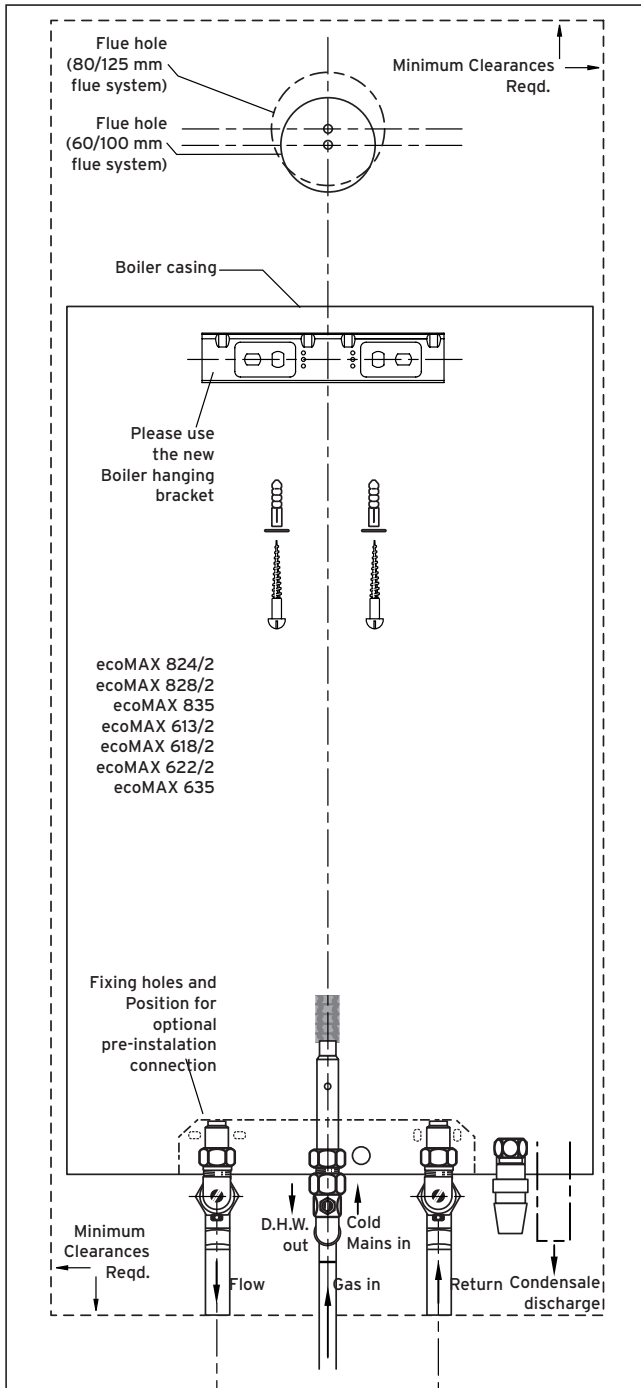

Fig. 4.2 Using Boiler template

4.4 Fitting the boiler hanging bracket

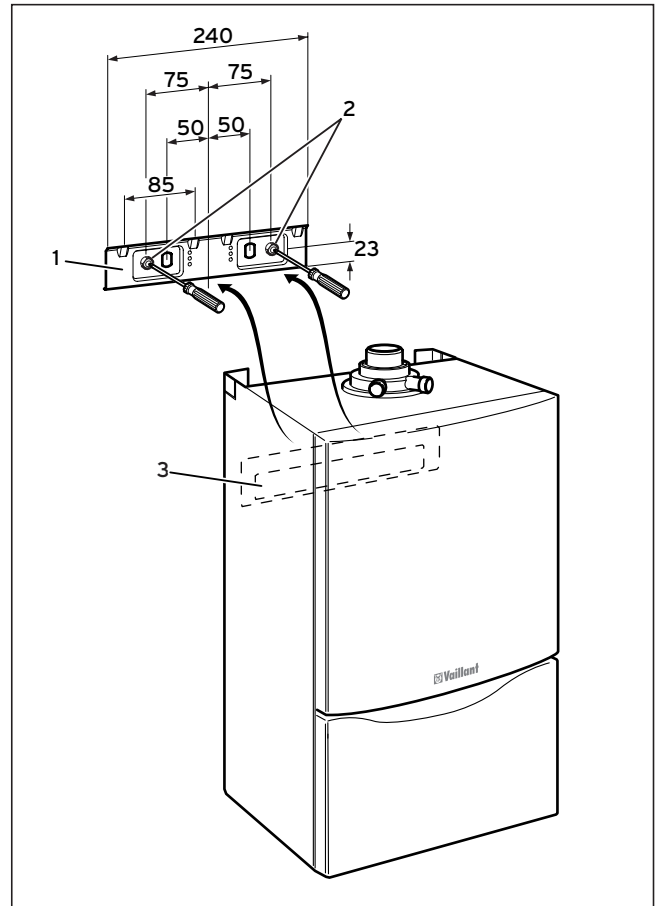

Fig. 4.3 Fitting the boiler

Fix the hanging bracket (2) to the wall using the screws supplied. (it may be necessary to use additional or alternative fixings to ensure adequate support).

Note:
If the boiler is to be fitted in a timber framed building ensure that the bracket is secured to a substantial part of the timber frame capable of taking the weight of the boiler.

4.5 Install the flue system

Install the flue system (refer to separate air/flue duct installation instructions)

4 Boiler installation sequence

4.6 Fitting the boiler

- Lift the boiler (3) up to the wall so that it is slightly above the hanging bracket (1).

 **Note:**
Lift the boiler from either side at the bottom edge.

- Lower the boiler slowly onto the hanging bracket so that the cross member at the rear of the boiler fully engages onto the hanging bracket.

4.7 Removing the front case

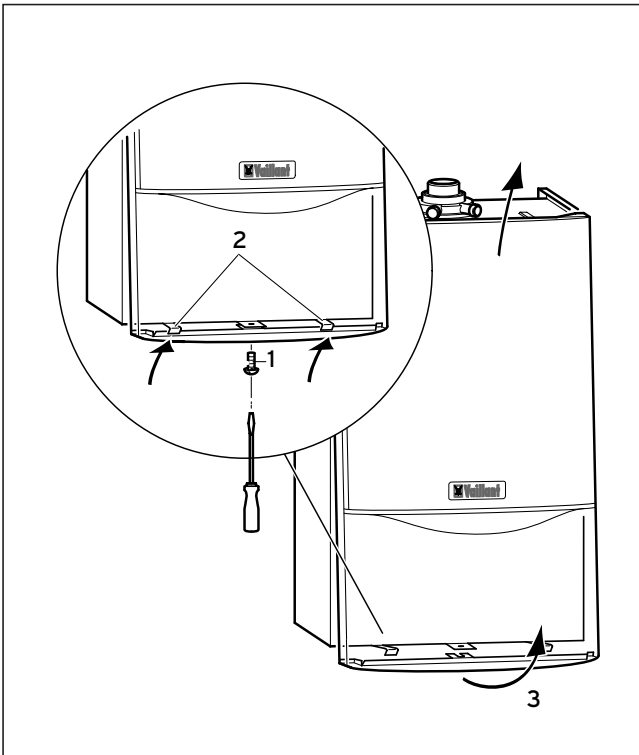

Fig. 4.4 Removing/Refitting the case

To remove the front section of the case, proceed as follows:

- Loosen the screw (1) on the bottom of the unit.
- Push in the two retaining clips (2) on the bottom of the appliance until the case is released.
- Grasp the front case (3) by its bottom edge, pull it towards the front and remove it by lifting it off the unit.

4.8 Cold water mains inlet and hot water outlet (ecoMAX 800)

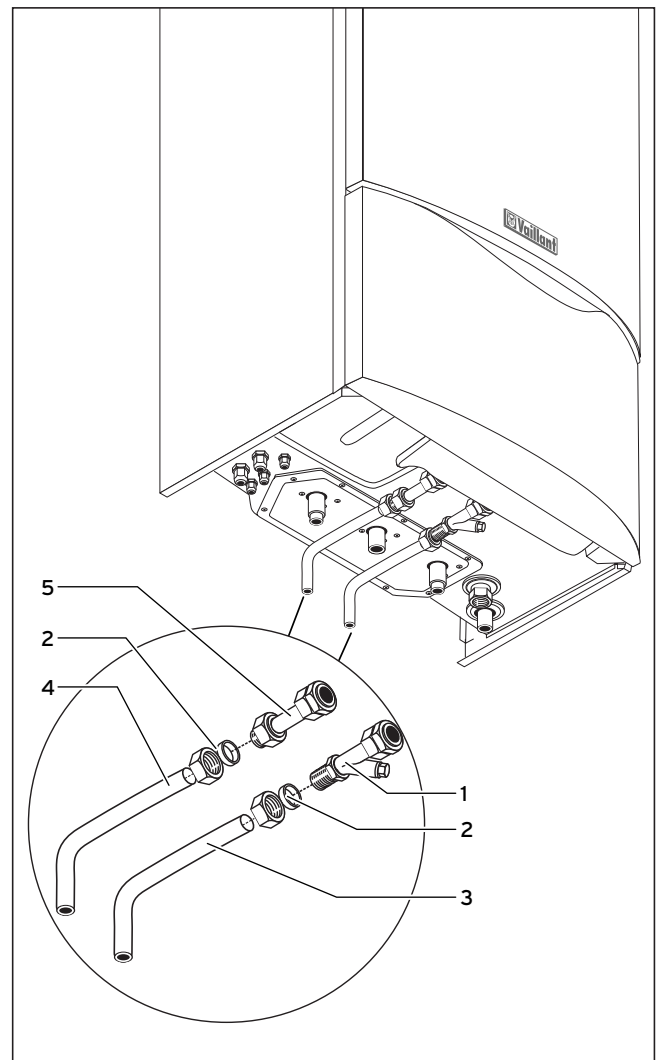

Fig. 4.5 Fitting hot and cold water connections ecoMAX 800

Flush all foreign matter from the mains supply before connecting to the boiler.

- Connect the cold water service valve (1) to the cold inlet water connection of the appliance with the washer provided and tighten.
- Connect a 15mm cold water inlet copper pipe (3) to the cold water service valve (1) and tighten.
- Connect a 15 mm hot water outlet pipe (4) to the outlet connection (5) of the appliance.

4.9 Gas supply

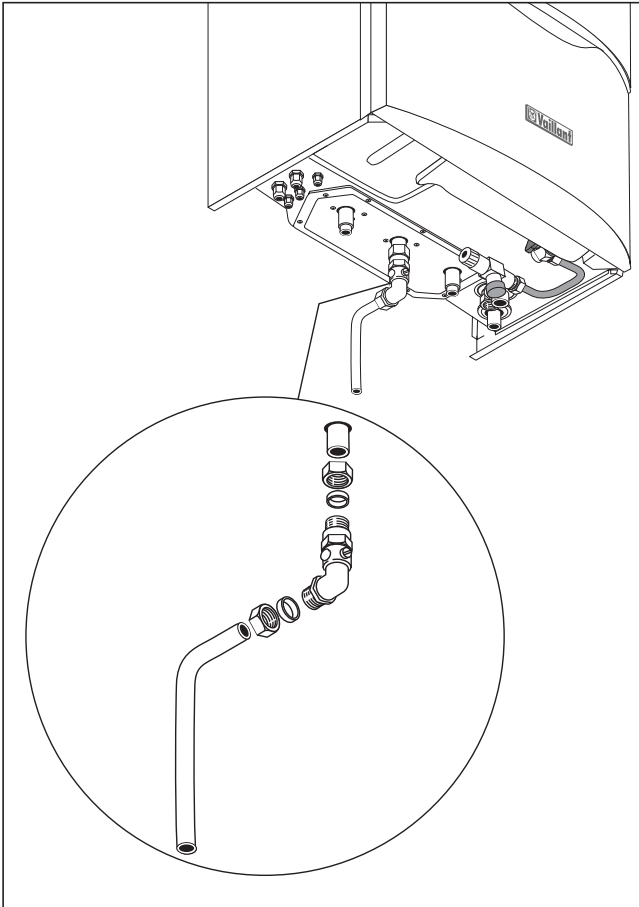

Fig. 4.6 Fitting the gas connection ecoMAX 800
(picture shows ecoMAX 800)

- Connect the compression gas service cock and 15 mm copper outlet tail as supplied with the appliance and tighten.
- Connect a gas supply pipe of not less than 15 mm diameter to the copper tail.
- Tighten all connections.
(Ensure the gas supply pipework is adequately sized such that a 20 mbar gas pressure is available at the boiler inlet at full flow rate).

Important note (ecoMAX 835 boiler only):
The gas supply pipe must not be less than 22 mm diameter.

4.10 Central heating flow and return pipework

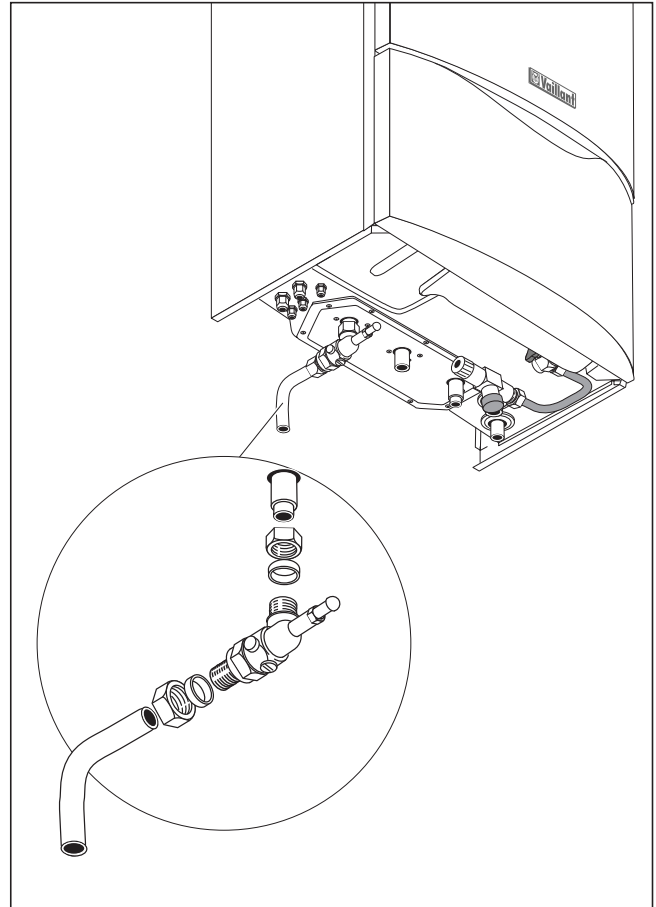

Fig. 4.7 Central heating flow and return pipework
(picture shows ecoMAX 800)

- Before connecting the heating circuit to the boiler, all pipework and radiators must be thoroughly flushed to remove any installation debris.
- Connect the central heating flow and return service valves to the appliance.
 - Connect the 22 mm copper pipe tails to the service valves as shown in the illustration and tighten the nuts.
 - Connect the central heating pipework to the flow and return tails.

Two additional tubes are supplied with the appliance for top connection of the flow and return pipework within the casing.

4 Boiler installation sequence

4.11 Pressure Relief Valve (ecoMAX 800)

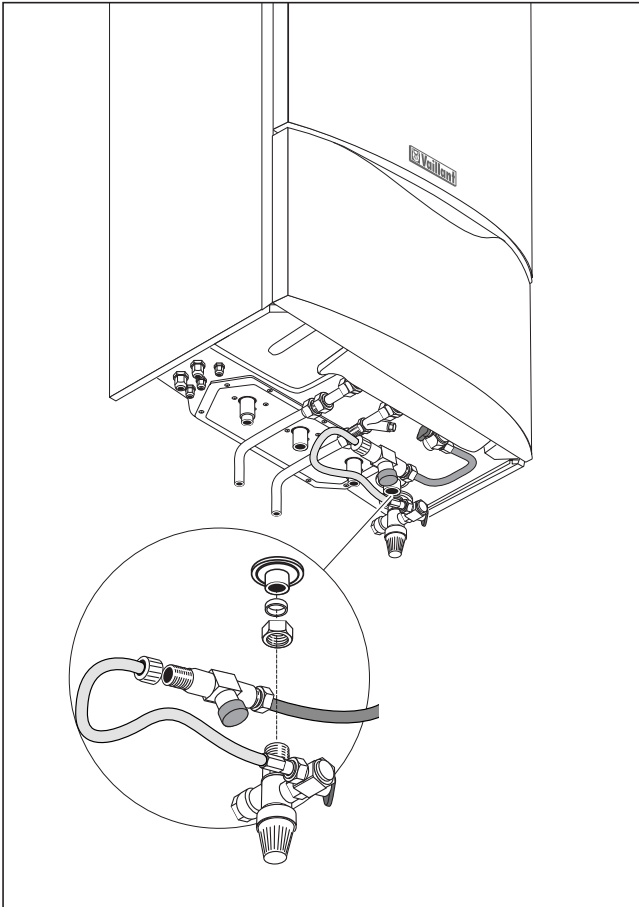

Fig. 4.8 Fitting the pressure relief valve (ecoMAX 800)

The pressure relief valve and filling loop connection is provided within the boiler cardboard box and should be assembled as shown below.

- Remove plug from connection (1).
- Fit and install the complete unit "pressure relief valve, filling valve and flexible connection" (2) to the connection (1).
- Connect the corrugated hose (3) to the double check valve (2a).
- Connect the discharge pipe (4) to the pressure relief valve.

The discharge pipework should be as short as possible and installed with a continuous fall away from the boiler. The pipe should terminate in a position which ensures that any discharge of water or steam from the valve cannot create a hazard to persons in or about the premises, or cause damage to any electrical components or external wiring, and the point of discharge should be clearly visible.

4.12 Pressure Relief Valve (ecoMAX 600)

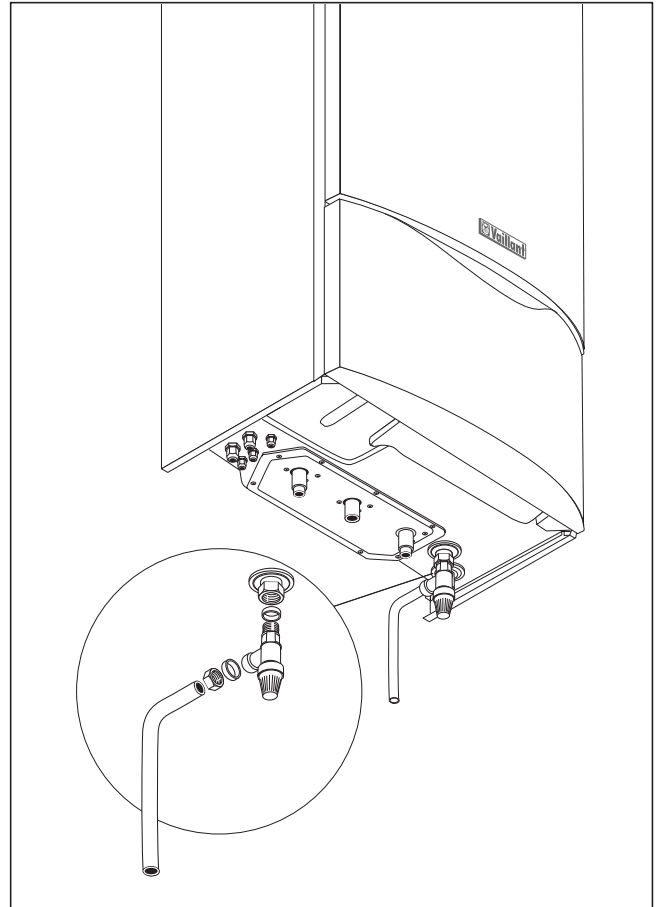

Fig. 4.9 Fitting the pressure relief valve (ecoMAX 600)

A pressure relief valve is provided within the boiler cardboard box and should be assembled as shown below. Connect a discharge pipe not less than 15 mm diameter to the outlet of this valve.

The discharge pipework should be as short as possible and installed with a continuous fall away from the boiler. The pipe should terminate in a position which ensures that any discharge of water or steam from the valve cannot create a hazard to persons in or about the premises, or cause damage to any electrical components or external wiring, and the point of discharge should be clearly visible.

4.13 Condensate drain (fig. 4.10)

Connect the boiler condensate drain (1) to the condensate discharge pipe (2) the condensate discharge pipe should be minimum of 19mm internal diameter (22mm external diameter for any pipework installed external to the property) and be made of an acid resistant material (e.g. plastic overflow pipe).

The discharge pipe from the boiler condensate drain must have a continuous fall (45mm per metre) and preferably be installed and terminated within the building to prevent freezing. The condensate discharge pipe must terminate in a suitable position, e.g.:

a) preferably the discharge pipe should be run and terminate internally to the house soil and vent stack (at least 450mm above the invert of the stack). A trap giving a water seal of at least 75mm (3) should be incorporated into the pipe run, and there must be an air break (4) in the discharge pipe upstream of the trap. This should be designed so that the condensate cannot be discharged into the house if the condensate pipe becomes blocked.

b) connecting into the internal discharge branch (e.g. sink waste or washing machine) with an external termination, the condensate discharge pipe should have a minimum diameter of 22mm with no length restriction and should incorporate a trap with a 75mm (3) seal. The connection should preferably be made down stream of the sink waste trap. If the connection is only possible upstream, then a air break is needed between the two traps. This is normally provided by the sink waste. c) terminating in a gully (5) below grid level (6) and above the water level. The external pipe length should be kept as short as possible to minimize the risk of freezing and should not be more than 3m.

d) At a condensate absorption point (soakaway) (7). The external pipe length should not be more than 3m

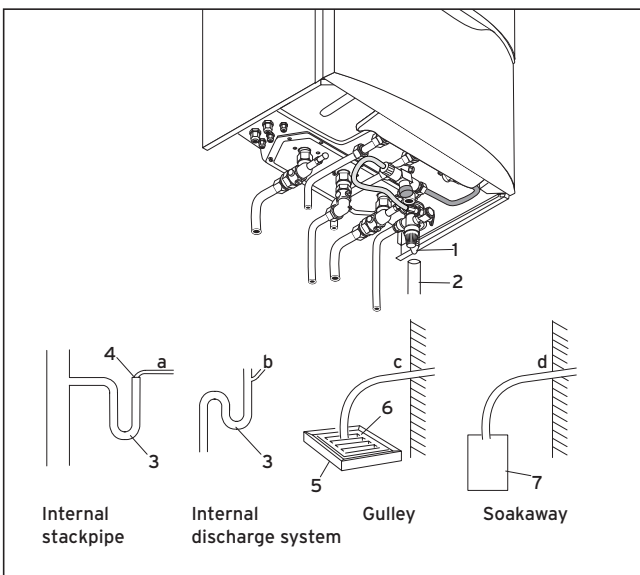

Fig. 4.10

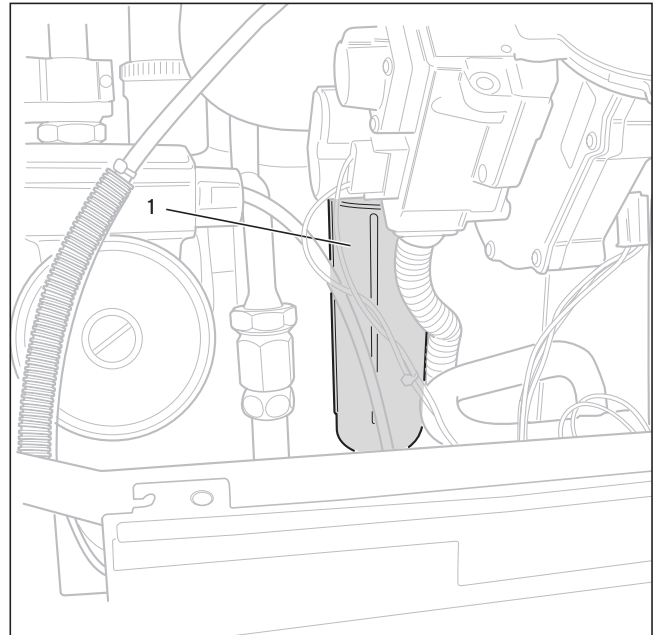

Fig. 4.11

Note:
 If it is necessary to install any condensate discharge pipework externally, then it should be kept as short as possible to a maximum length of 3m, be insulated with waterproof insulation and have a continuous fall of a least 2.50 (i.e. 45mm for every metre length).

An optional siphon condensate discharge accessory is available (Art. No. 2370104) and is for use where external discharge pipework is very exposed and at risk of freezing. This accessory is for installation within the condensate discharge pipework immediately below the boiler. Refer to 'BS 6798 Specification for installation of gas-fired boilers of rated input not exceeding 70 kW net' for further information. Before operating the boiler the condensate trap (1, fig.4.11) must be filled with water as described in relevant section.

4.14 Connection to a VANTAGE cylinder (ecoMAX 600)

- For connecting a Vaillant VANTAGE cylinder please refer to the VANTAGE installation instructions provided with the cylinder.

4.15 Connect the flue system to the boiler

- Refer to separate air/flue duct installation instructions included with the boiler.

4 Boiler installation sequence

4.16 Electrical installation

4.16.1 General requirements

All electrical work shall be carried out by a competent person and shall comply with BS7671 (IEE Regulations). In IE, reference should be made to the current edition of the ETCI rules. The boiler is supplied for connection to 230 V, ~ 50 Hz supply fused at 3 A rating. Connection to the mains supply shall be made via a fused 3 pin plug to an unswitched shuttered socket, both complying to the requirements of BS1363.

(Alternatively, connection may be made via a 3 A fused double pole isolator having a contact separation of at least 3 mm in all poles and supplying the boiler and controls only). The point of connection to the mains supply must allow complete electrical isolation of the boiler and its ancillary controls. It should be readily accessible and adjacent to the boiler. A 3 core flexible cord according to BS6500 tables 6, 8 or 16 (3 x 0.75 to 3 x 1.5 mm²) should be used.



Warning:

This appliance must be earthed.



Note:

DO NOT use boiler terminal connections 7-8-9.



Important:

Ensure that all cords pass through the cable clamps in the rear of the control box and are securely fixed. Ensure that the power supply is connected such that the current carrying conductors become taut before the earth conductor should the supply cord slip from the cable clamp.



Caution:

Mains connection terminals L and N remain live even when the boiler on/off control is switched off.

4.16.2 Connection to the main supply

- Remove the front case and lower the control panel.
- Unclip the bottom of the terminal box cover and hinge back to reveal the connection plugs.
- Pull out the power L, N and earth plug.
- Feed the power supply flex into the appliance and the control panel through the cable clamps provided and tighten.
- Connect the flex to the L,N and earth plug, reconnect plug to terminal block.

Green/yellow (earth) wire - boiler terminal Earth sign
Blue (neutral) wire - boiler terminal N
Brown (live) wire - boiler terminal L



Note:

DO NOT use boiler terminal connections 7-8-9.

- Refit the terminal box cover by pushing into place until it clips back into position.
- Raise the control panel.

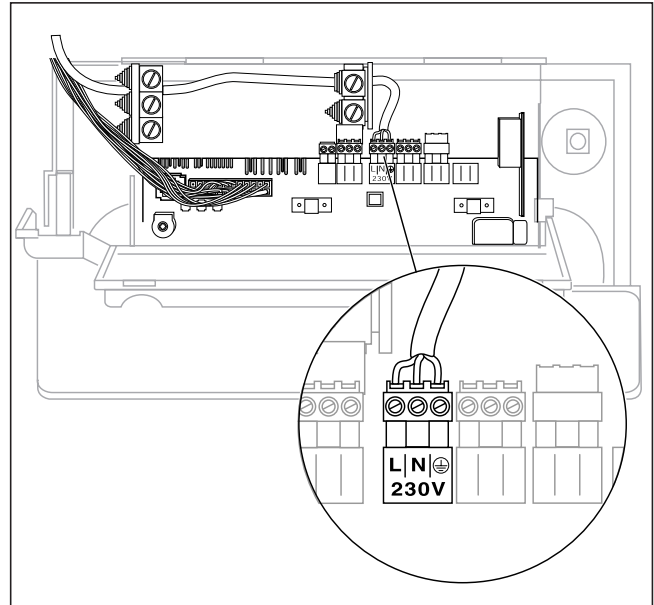

Fig. 4.12 Wiring system

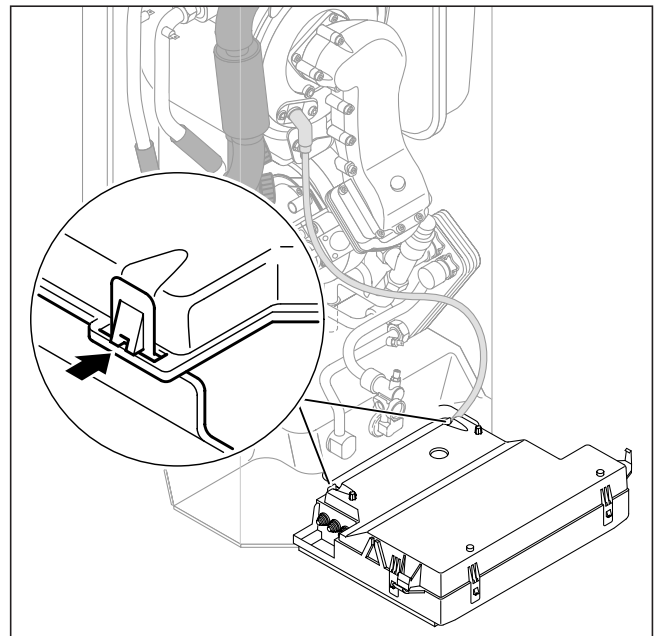

Fig. 4.13 Exposed rear view of electronic box

4.16.3 Electronic board layout

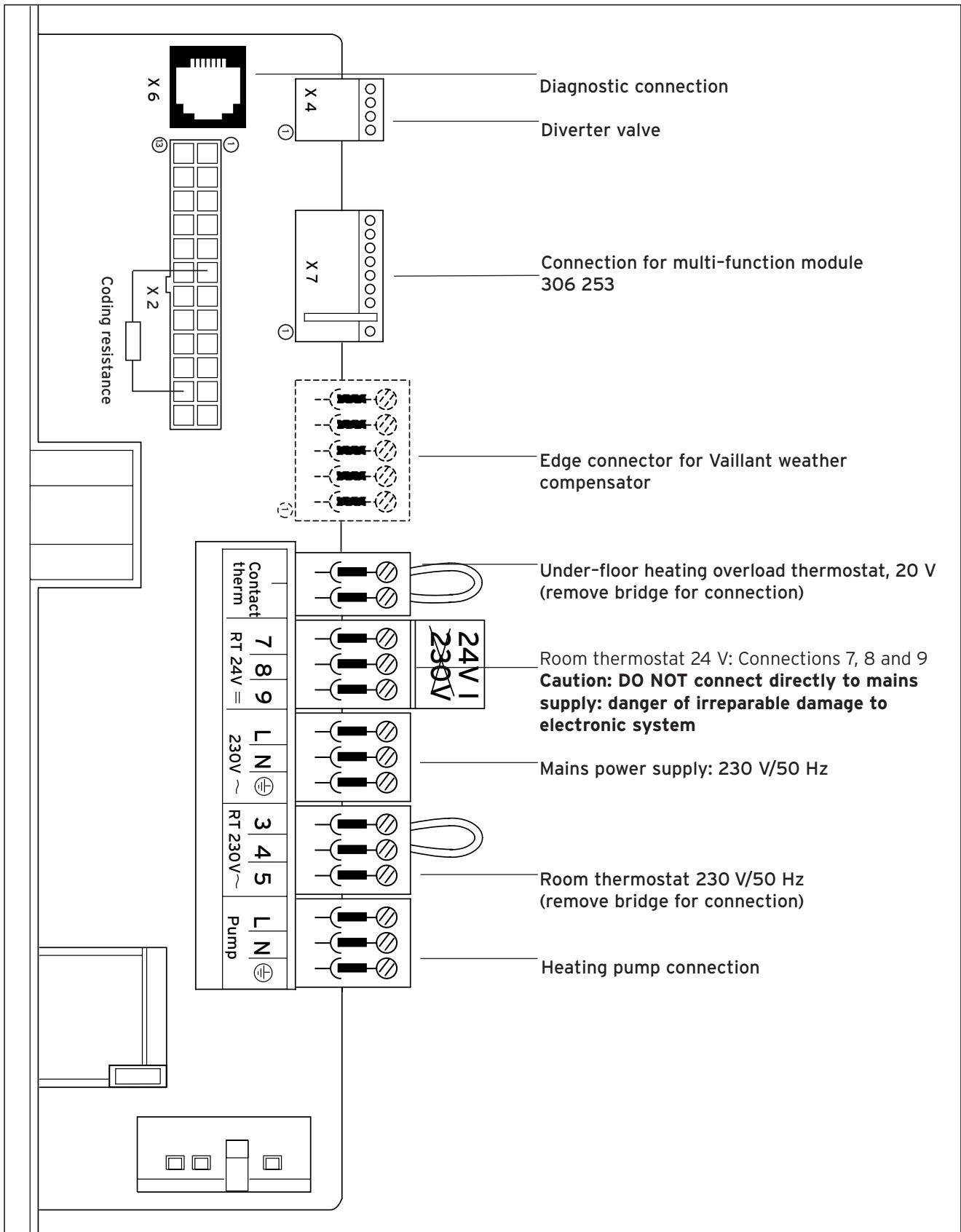

Fig. 4.14: Connection wiring ecoMAX 613/2, 618/2, 622/2, 824/2, 828/2

4 Boiler installation sequence

4.16.3 Electronic board layout (continued)

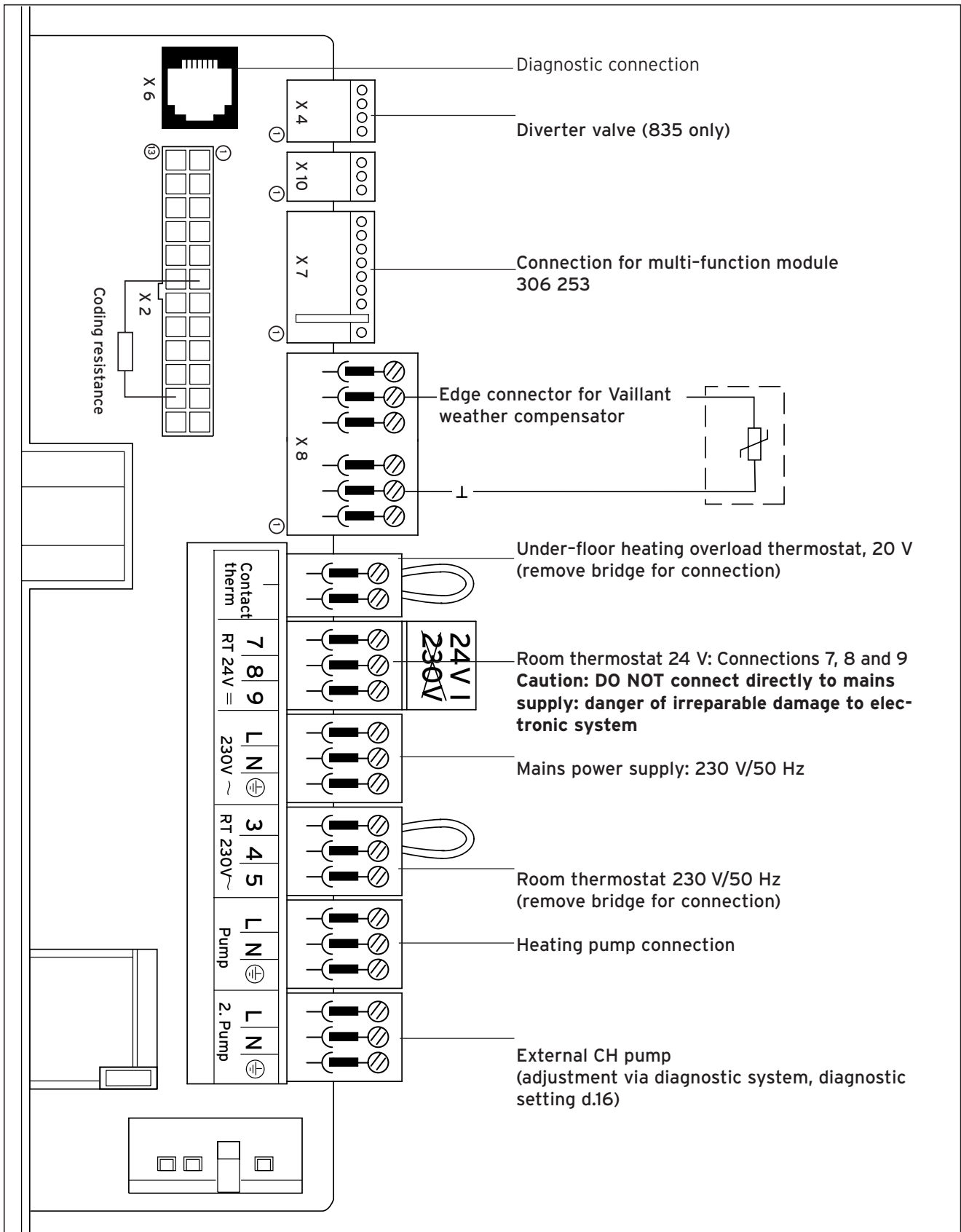

Fig. 4.15: Connection wiring ecoMAX 635, 835

4.16.3 Electronic board layout (continued)

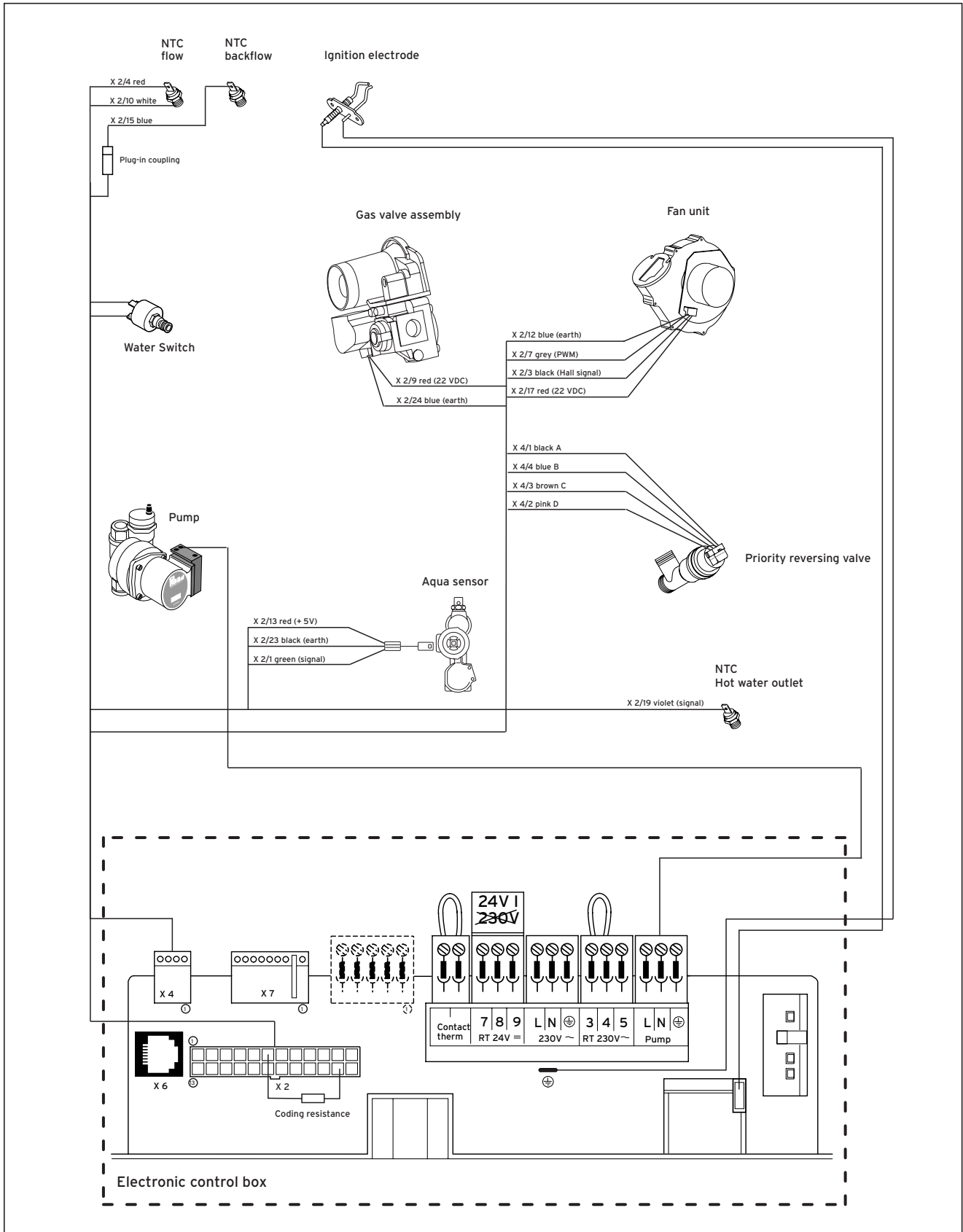

Fig. 4.16 Connection wiring ecoMAX 824/2, 828/2

4 Boiler installation sequence

4.16.3 Electronic board layout (continued)

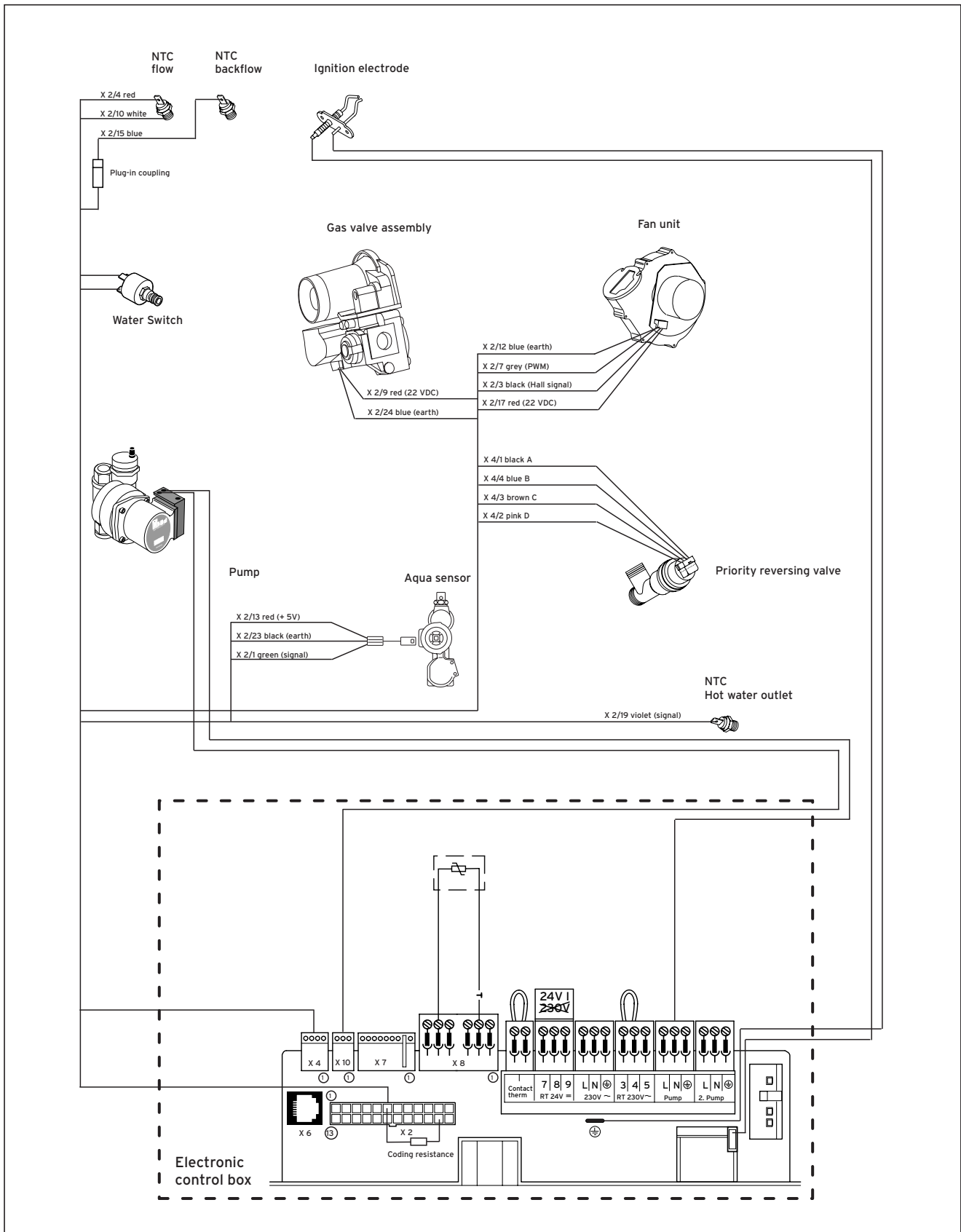

Fig. 4.17: Connection wiring ecoMAX 835

4.16.3 Electronic board layout (continued)

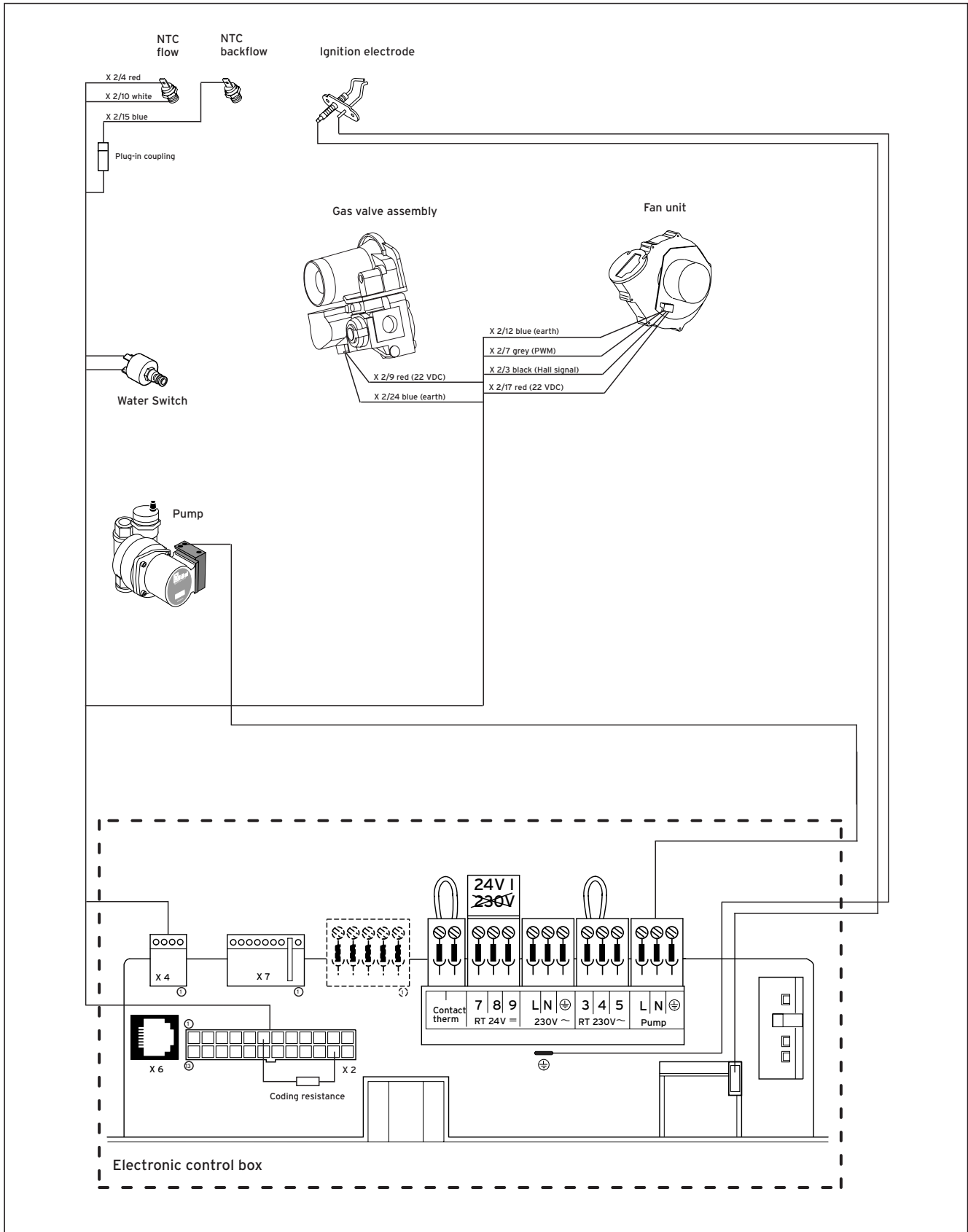

Fig. 4.18 Connection wiring ecoMAX 613/2, 618/2, 622/2

4 Boiler installation sequence

4.16.3 Electronic board layout (continued)

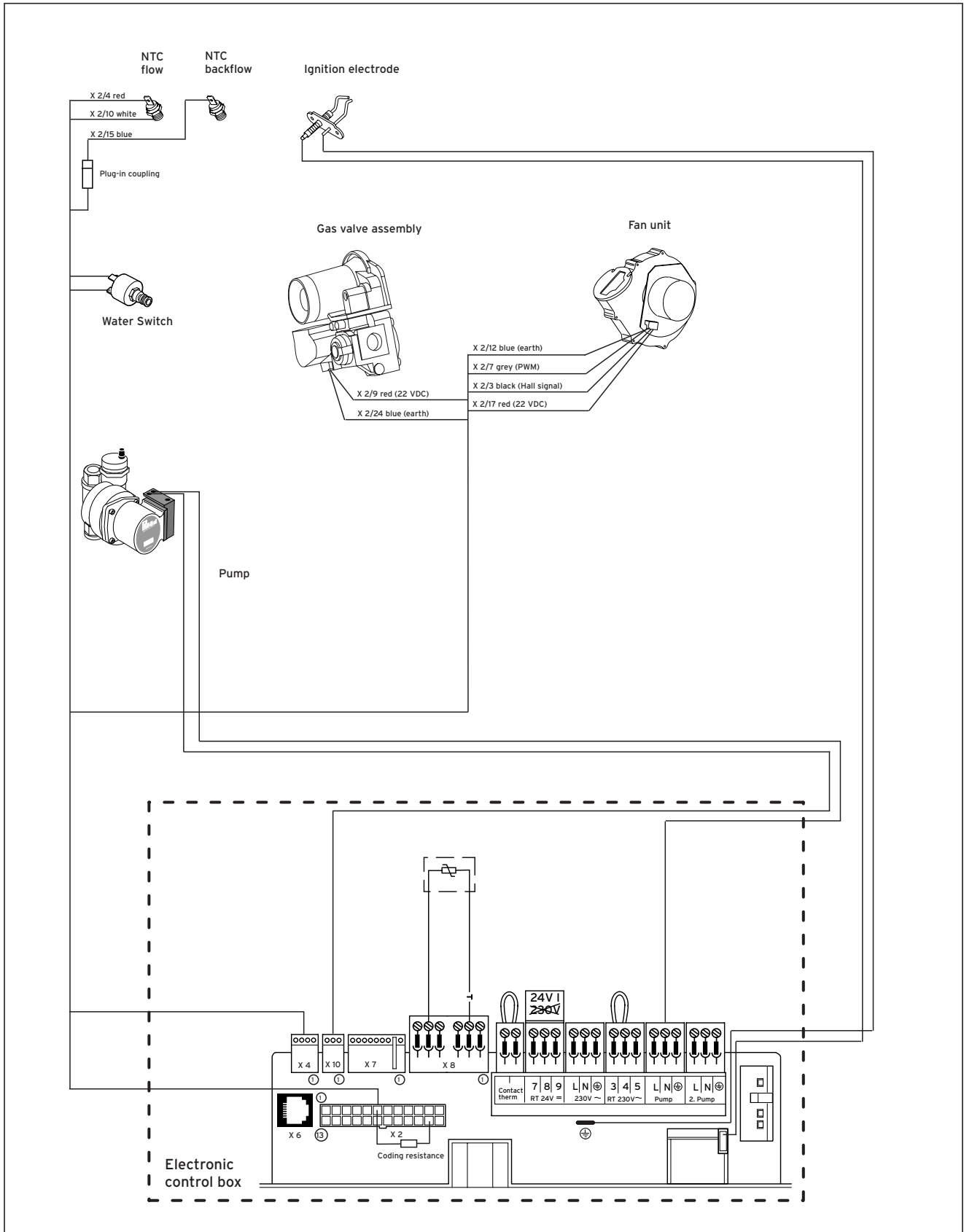

Fig. 4.19: Connection wiring ecoMAX 635

4.16.4 Connection details for programmable thermostats

ACL Drayton Lyfestyle PT271, PT371	
ACL Drayton Digistat 2, 3, 4	
ACL Drayton Digistat RF - SCR Receiver	
Danfoss Randall TP4, TP5, TP5E	
Danfoss Randall TP5E RF with receiver RX1	
Danfoss Randall TP75	
Grässlin Towerchron RTC7	
Honeywell CM61, CM67, CM31, CM37	
Horstmann Centaurstat 1, 7	
Landis & Staefa REV 11, REV 15, REV 22	
Smiths Timeguard ProgramaSTAT PRT11, PRT17	
Sunvic TLX 6501	
Sunvic TLX RFP, TLX RFD	
Vaillant VRT 230, 220	

Fig. 4.20

4.17 Controls (ecoMAX 800)

4.17.1 External electrical controls

The boiler terminals 3, 4 and 5 are for connecting external electrical controls such as a time switch and/or room thermostat. Terminals 3 and 4 are linked together when the boiler is supplied. If external controls are used, this link must be removed, and the controls connected across terminals 3 and 4. Terminal 5 is an additional neutral connection for external neutrals such as from the anticipator of a room thermostat.

4.17.2 Connection of external controls

4.17.3 Connection details for programmable room thermostats

Fig. 4.19 shows the connection details where a programmable room thermostat (time switch with built in room thermostat) is used to control the boiler.

Important:
 The arrowed numbers indicate connection into the relevant terminal in the boiler terminal strip.

4 Boiler installation sequence

4.17.4 Connection details for time switch

ACL Drayton Tempus 1, Tempus 2 Lyfestyle LP111, LP711	<table border="1"> <tr><td>L</td><td>N</td><td>1</td><td>2</td><td>3</td><td>4</td></tr> <tr><td>↓</td><td>↓</td><td>↓</td><td>↓</td><td>↓</td><td>↓</td></tr> <tr><td>L</td><td>N</td><td>3</td><td>4</td><td></td><td></td></tr> </table>	L	N	1	2	3	4	↓	↓	↓	↓	↓	↓	L	N	3	4																							
L	N	1	2	3	4																																			
↓	↓	↓	↓	↓	↓																																			
L	N	3	4																																					
ACL Drayton Switchmaster SM300	<table border="1"> <tr><td>L</td><td>N</td><td>1</td><td>2</td><td>3</td><td>4</td></tr> <tr><td>↓</td><td>↓</td><td>↓</td><td>↓</td><td>↓</td><td>↓</td></tr> <tr><td>L</td><td>N</td><td>4</td><td></td><td>3</td><td></td></tr> </table>	L	N	1	2	3	4	↓	↓	↓	↓	↓	↓	L	N	4		3																						
L	N	1	2	3	4																																			
↓	↓	↓	↓	↓	↓																																			
L	N	4		3																																				
ACL Drayton Switchmaster 980	<table border="1"> <tr><td>L</td><td>N</td><td>1</td><td>2</td><td>A</td><td>B</td><td>C</td><td>3</td><td>4</td></tr> <tr><td>↓</td><td>↓</td><td>↓</td><td>↓</td><td>↓</td><td>↓</td><td>↓</td><td>↓</td><td>↓</td></tr> <tr><td>L</td><td>N</td><td>4</td><td></td><td></td><td></td><td></td><td>3</td><td></td></tr> </table>	L	N	1	2	A	B	C	3	4	↓	↓	↓	↓	↓	↓	↓	↓	↓	L	N	4					3													
L	N	1	2	A	B	C	3	4																																
↓	↓	↓	↓	↓	↓	↓	↓	↓																																
L	N	4					3																																	
Danfoss Randall 103 Series	<table border="1"> <tr><td>1</td><td>2</td><td>3</td><td>6</td><td>5</td><td>E</td></tr> <tr><td>↓</td><td>↓</td><td>↓</td><td>↓</td><td>↓</td><td>↓</td></tr> <tr><td>4</td><td></td><td>3</td><td>L</td><td>N</td><td>E</td></tr> </table>	1	2	3	6	5	E	↓	↓	↓	↓	↓	↓	4		3	L	N	E																					
1	2	3	6	5	E																																			
↓	↓	↓	↓	↓	↓																																			
4		3	L	N	E																																			
Danfoss Randall Set 1E, TS975	<table border="1"> <tr><td>L</td><td>N</td><td>E</td><td>1</td><td>2</td><td>3</td><td>4</td><td>5</td><td>6</td></tr> <tr><td>↓</td><td>↓</td><td>↓</td><td>↓</td><td>↓</td><td>↓</td><td>↓</td><td>↓</td><td>↓</td></tr> <tr><td>L</td><td>N</td><td>E</td><td></td><td></td><td></td><td>4</td><td>3</td><td></td></tr> </table>	L	N	E	1	2	3	4	5	6	↓	↓	↓	↓	↓	↓	↓	↓	↓	L	N	E				4	3													
L	N	E	1	2	3	4	5	6																																
↓	↓	↓	↓	↓	↓	↓	↓	↓																																
L	N	E				4	3																																	
Danfoss Randall TS715	<table border="1"> <tr><td>L</td><td>N</td><td>1</td><td>2</td><td>3</td><td>4</td></tr> <tr><td>↓</td><td>↓</td><td>↓</td><td>↓</td><td>↓</td><td>↓</td></tr> <tr><td>L</td><td>N</td><td>3</td><td></td><td></td><td>4</td></tr> </table>	L	N	1	2	3	4	↓	↓	↓	↓	↓	↓	L	N	3			4																					
L	N	1	2	3	4																																			
↓	↓	↓	↓	↓	↓																																			
L	N	3			4																																			
Grässlin Towerchron QE1, QM1	<table border="1"> <tr><td>L</td><td>N</td><td>1</td><td>2</td><td>3</td><td>4</td></tr> <tr><td>↓</td><td>↓</td><td>↓</td><td>↓</td><td>↓</td><td>↓</td></tr> <tr><td>L</td><td>N</td><td></td><td></td><td>3</td><td>4</td></tr> </table>	L	N	1	2	3	4	↓	↓	↓	↓	↓	↓	L	N			3	4																					
L	N	1	2	3	4																																			
↓	↓	↓	↓	↓	↓																																			
L	N			3	4																																			
Honeywell ST610A, ST6100C	<table border="1"> <tr><td>L</td><td>N</td><td>1</td><td>2</td><td>3</td><td>4</td></tr> <tr><td>↓</td><td>↓</td><td>↓</td><td>↓</td><td>↓</td><td>↓</td></tr> <tr><td>L</td><td>N</td><td>3</td><td></td><td></td><td>4</td></tr> </table>	L	N	1	2	3	4	↓	↓	↓	↓	↓	↓	L	N	3			4																					
L	N	1	2	3	4																																			
↓	↓	↓	↓	↓	↓																																			
L	N	3			4																																			
Horstmann Channel Plus H11, H17, 425 Coronet	<table border="1"> <tr><td>L</td><td>N</td><td>E</td><td>1</td><td>2</td><td>3</td><td>4</td><td>5</td><td>6</td></tr> <tr><td>↓</td><td>↓</td><td>↓</td><td>↓</td><td>↓</td><td>↓</td><td>↓</td><td>↓</td><td>↓</td></tr> <tr><td>L</td><td>N</td><td>E</td><td></td><td></td><td></td><td>4</td><td>3</td><td></td></tr> </table>	L	N	E	1	2	3	4	5	6	↓	↓	↓	↓	↓	↓	↓	↓	↓	L	N	E				4	3													
L	N	E	1	2	3	4	5	6																																
↓	↓	↓	↓	↓	↓	↓	↓	↓																																
L	N	E				4	3																																	
Horstmann Centaur Plus C11, C17	<table border="1"> <tr><td>L</td><td>N</td><td>E</td><td>1</td><td>2</td><td>3</td><td>4</td></tr> <tr><td>↓</td><td>↓</td><td>↓</td><td>↓</td><td>↓</td><td>↓</td><td>↓</td></tr> <tr><td>L</td><td>N</td><td>E</td><td></td><td>3</td><td></td><td>4</td></tr> </table>	L	N	E	1	2	3	4	↓	↓	↓	↓	↓	↓	↓	L	N	E		3		4																		
L	N	E	1	2	3	4																																		
↓	↓	↓	↓	↓	↓	↓																																		
L	N	E		3		4																																		
Landis & Staefa RWB7, RWB30	<table border="1"> <tr><td>L</td><td>N</td><td>1</td><td>2</td><td>3</td><td>4</td></tr> <tr><td>↓</td><td>↓</td><td>↓</td><td>↓</td><td>↓</td><td>↓</td></tr> <tr><td>L</td><td>N</td><td></td><td>3</td><td></td><td>4</td></tr> </table>	L	N	1	2	3	4	↓	↓	↓	↓	↓	↓	L	N		3		4																					
L	N	1	2	3	4																																			
↓	↓	↓	↓	↓	↓																																			
L	N		3		4																																			
Potterton Myson EP 4002, EP 5002	<table border="1"> <tr><td>N</td><td>A</td><td>B</td><td>C</td><td>D</td><td>L</td><td>N</td><td>1</td><td>2</td><td>3</td><td>4</td><td>5</td><td>E</td></tr> <tr><td>↓</td><td>↓</td><td>↓</td><td>↓</td><td>↓</td><td>↓</td><td>↓</td><td>↓</td><td>↓</td><td>↓</td><td>↓</td><td>↓</td><td>↓</td></tr> <tr><td></td><td></td><td></td><td></td><td></td><td>L</td><td>N</td><td></td><td></td><td></td><td>4</td><td>3</td><td>E</td></tr> </table>	N	A	B	C	D	L	N	1	2	3	4	5	E	↓	↓	↓	↓	↓	↓	↓	↓	↓	↓	↓	↓	↓						L	N				4	3	E
N	A	B	C	D	L	N	1	2	3	4	5	E																												
↓	↓	↓	↓	↓	↓	↓	↓	↓	↓	↓	↓	↓																												
					L	N				4	3	E																												
Smiths Timeguard SupplyMASTER FST11, FST17	<table border="1"> <tr><td>1</td><td>2</td><td>3</td><td>4</td><td>6</td><td>5</td><td>E</td><td>mains supply</td></tr> <tr><td>↓</td><td>↓</td><td>↓</td><td>↓</td><td>↓</td><td>↓</td><td>↓</td><td>↓</td></tr> <tr><td>4</td><td>3</td><td>2/L</td><td>1/N</td><td>L</td><td>N</td><td>E</td><td></td></tr> </table>	1	2	3	4	6	5	E	mains supply	↓	↓	↓	↓	↓	↓	↓	↓	4	3	2/L	1/N	L	N	E																
1	2	3	4	6	5	E	mains supply																																	
↓	↓	↓	↓	↓	↓	↓	↓																																	
4	3	2/L	1/N	L	N	E																																		
Sunvic Select 107	<table border="1"> <tr><td>L</td><td>N</td><td>1</td><td>2</td><td>3</td><td>4</td></tr> <tr><td>↓</td><td>↓</td><td>↓</td><td>↓</td><td>↓</td><td>↓</td></tr> <tr><td>L</td><td>N</td><td>3</td><td></td><td></td><td>4</td></tr> </table>	L	N	1	2	3	4	↓	↓	↓	↓	↓	↓	L	N	3			4																					
L	N	1	2	3	4																																			
↓	↓	↓	↓	↓	↓																																			
L	N	3			4																																			

Fig. 4.21

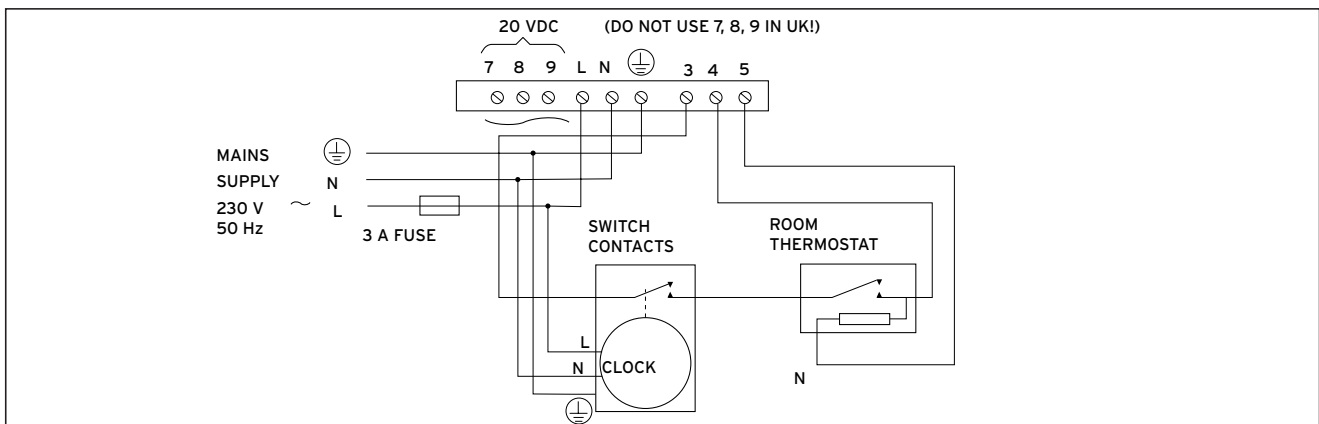

Fig. 4.22

4.17.5 Connection details for external time switches and boiler terminal strip

Fig. 4.20 shows the connection details where a time switch is used without a room thermostat to control the boiler.

 **Important:**
The arrowed numbers indicate connection into the relevant terminal in the boiler terminal strip.

If a room thermostat is to be connected in addition to a time switch the wire between the time switch "ON" terminal and boiler terminal 4 should be broken by the contacts of the room thermostat (see schematic layout, Fig. 4.21).

4.17.6 Vaillant optional plug in timer accessories

Refer to the instructions supplied with the optional accessories for connection details. Upon completion of all electrical connections refit the terminal box cover by pushing into place. The cover is secured by two locking clips.

4.18 Controls (ecoMAX 600)

4.18.1 External electrical controls

The boiler terminals 3, 4 and 5 are for connecting external electrical controls such as a programmer, room thermostat, etc. Terminals 3 and 4 are linked together when the boiler is supplied. If external controls are used, this link must be removed, and the controls connected across terminals 3 and 4. Terminal 5 is an additional neutral connection for external controls.

4.18.2 Connection of external electrical controls

4.18.3 Connection details using an external wiring centre

The boiler should be connected to the system controls using an external wiring centre. Fig. 4.22, 4.23 shows connection details for a system utilising a 3 port mid position motorised valve, figure 4.24, 4.25 shows the connection details for a system utilising two 2 port motorised valves (Important: the arrowed numbers indicate connection into the relevant terminal of the external wiring centre).

4.19 Thermostatic radiator valves

The boiler has a built in automatic bypass valve making it ideal for use in systems with thermostatic radiator valves (no separate system bypass is required). For optimum fuel economy where TRV's are used they must be used in conjunction with a boiler control interlock. A programmable room thermostat or separate timer and room thermostat will ensure complete boiler shut down when the heating demand is satisfied. (The radiator in the room containing the room thermostat should not be fitted with a TRV).

4.20 Frost protection

The boiler has an integral frost thermostat which is designed for protection of the boiler. To protect remote or exposed parts of the heating system or property additional frost protection measures must be taken such as the installation of an external frost thermostat. This frost thermostat should be connected across the boiler terminals 3 and 4, in parallel with any external heating controls.

 **Note:**
External frost protection cannot be used when plug in timers are utilised.

4.21 Circulating pump

The boiler incorporates a built in circulating pump that is fully prewired (no additional wiring is necessary). The pump incorporates an automatic overrun period after the boiler switches off.

4.22 Anti-cycling 'economiser' control

The boiler incorporates a built in anti-cycling control to ensure that energy wasteful short cycling of the boiler cannot occur. This control prevents the boiler from re-igniting for a preset period after central heating operation (the hot water operation is unaffected by this control and hot water can be drawn at any time).

 **Note:**
To temporarily override the anti-cycling control turn the main boiler on/off switch to the off position "O" and then back to the on position "I" after a few seconds.

4.23 Automatic pump spin control (APS)

The boiler incorporates a built in control which will spin the built in circulating pump and operate the diverter valve (ecoMAX 800) once in a 23 hour period. This control helps to prevent seizure when the boiler is not operated for a period of time. This control is not active when the power supply to the appliance is turned off.

4 Boiler installation sequence

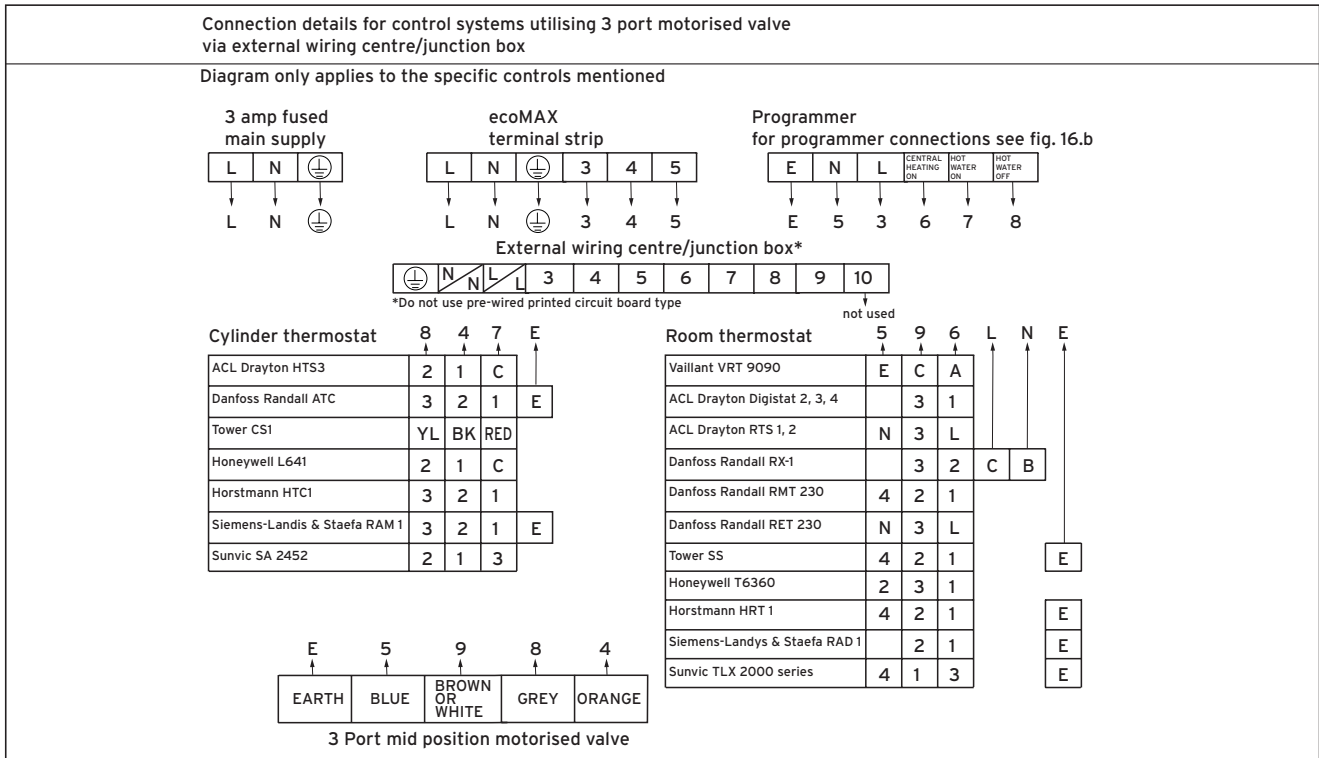

Fig. 4.23

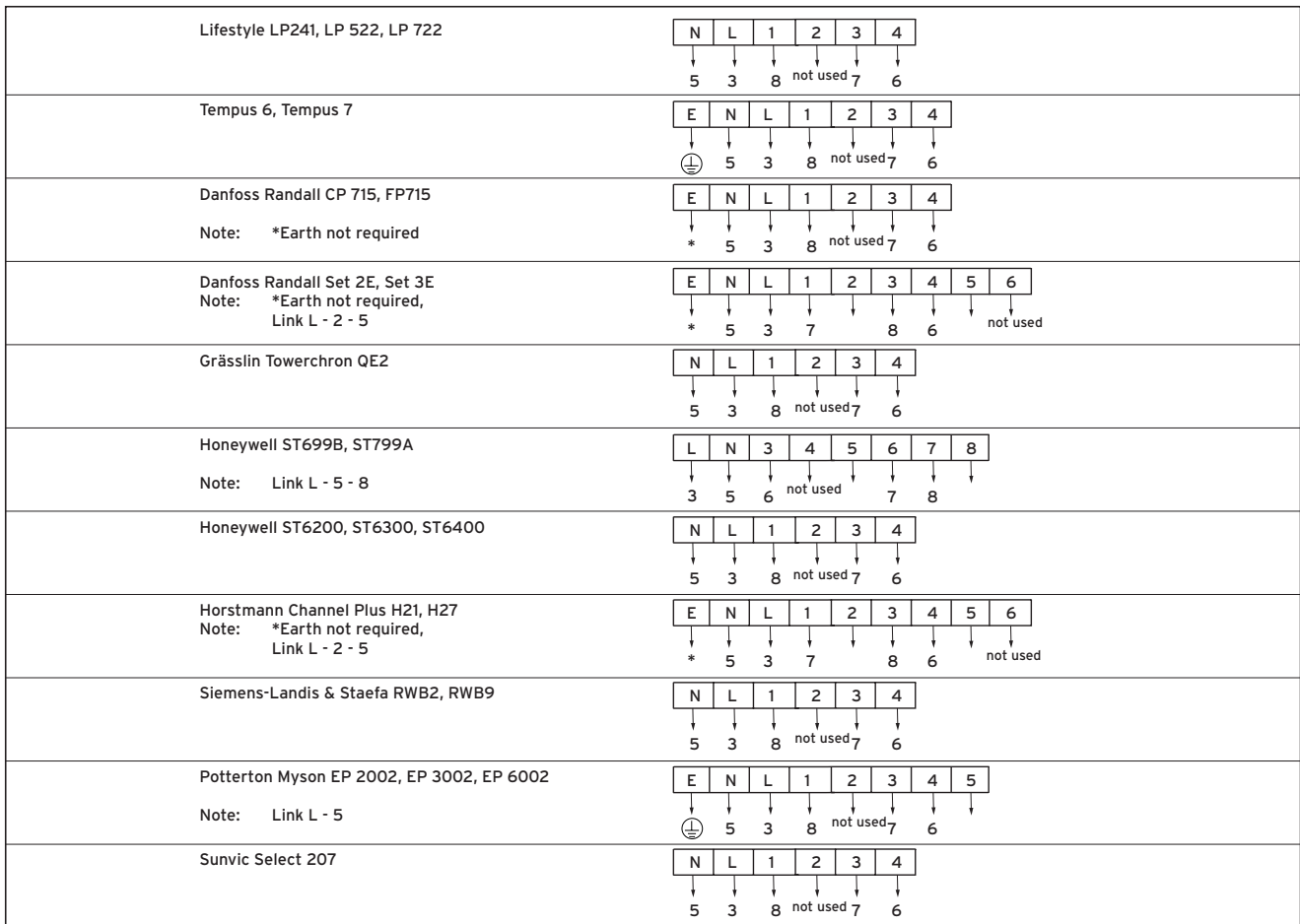

Fig. 4.24

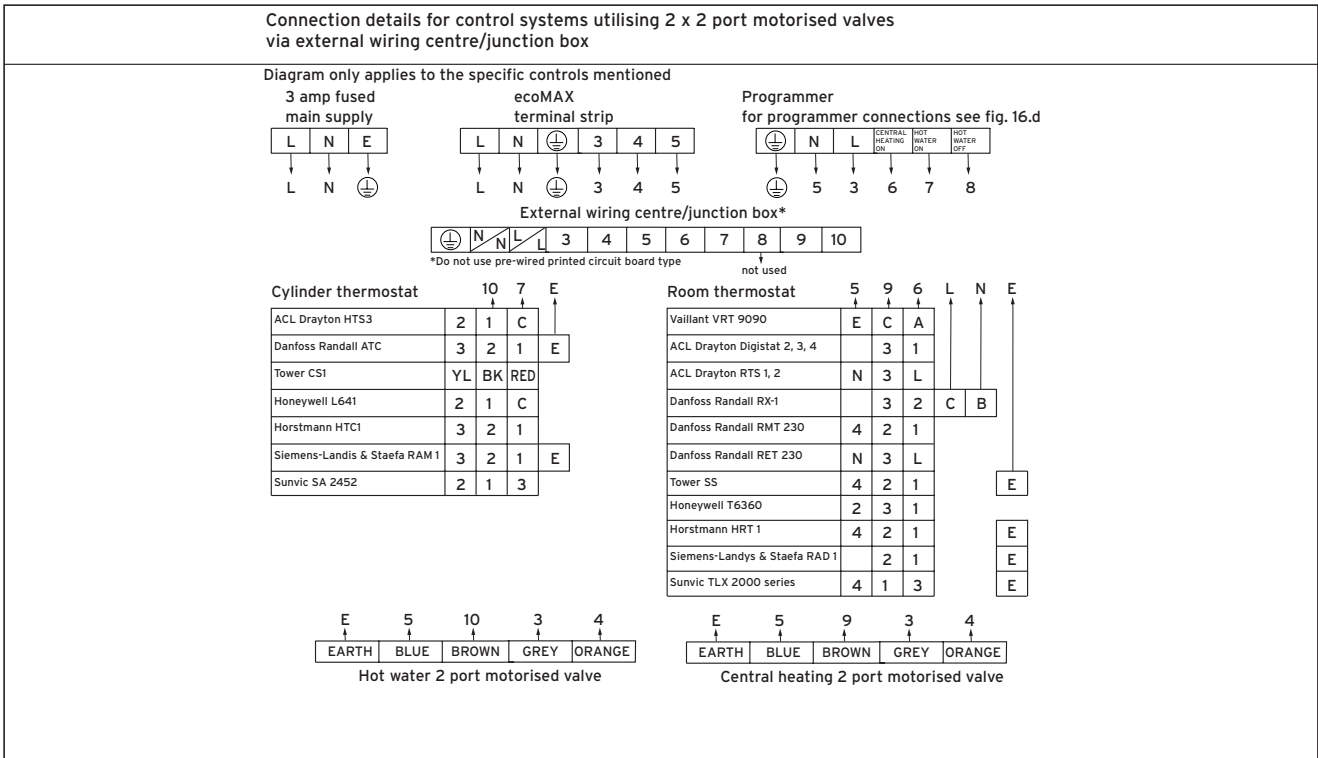

Fig. 4.25

Lifestyle LP241, LP 522, LP 722	
Tempus 6, Tempus 7	
Danfoss Randall CP 715, FP715 Note: *Earth not required	
Danfoss Randall Set 2E, Set 3E Note: *Earth not required, Link L - 2 - 5	
Grässlin Towerchron QE2	
Honeywell ST699B, ST799A Note: Link L - 5 - 8	
Honeywell ST6200, ST6300, ST6400	
Horstmann Channel Plus H21, H27 Note: *Earth not required, Link L - 2 - 5	
Siemens-Landis & Staefa RWB2, RWB9	
Potterton Myson EP 2002, EP 3002, EP 6002 Note: Link L - 5	
Sunvic Select 207	

Fig. 4.26

5 Commissioning Part I

5 Commissioning Part I

5.1 Preliminary electrical checks

Check the electrical installation by carrying out short circuit, earth continuity and resistance to earth tests and a check for correct polarity.

5.2 Gas supply

The complete gas installation including the gas meter must be inspected, tested for soundness and purged in accordance with BS 6891. In IE the current edition of IS 813. The gas supply to the boiler can be purged by slackening the gas service valve beneath the boiler. Ensure that there is adequate ventilation, extinguish all naked flames and do not smoke whilst purging. After purging, the gas service valve connection must be retightened and tested for soundness. (The boiler itself does not require purging as this will be done by the automatic burner sequence control).

5.3 Cold water supply (ecoMAX 800)

Open all domestic hot water taps supplied by the boiler, turn on the mains water supply to the boiler and open the mains water isolating valve below the boiler. Water will now flow through the boiler to the hot taps. Starting with the lowest tap supplied, turn the hot taps off one at a time until the hot water pipework is purged of air. Check all hot and cold water pipework for leaks. Insert drawing showing 2 filling valve positions

5.4 Filling the heating system (ecoMAX 800)

Proceed as follows to fill the system:

- Open all radiator valves on the system.
- Ensure that the boiler CH service valves are open.
- Check the flexible filling loop is connected.
- Locate the filling valve handle (1) and open.
- Locate the filling valve handle (2) and open to allow water to enter the system. Starting with the lowest radiator, open the radiator air release until water (clear of bubbles) is emitted.
- Repeat this at all radiators until the complete system is full, all air locks have been cleared and the boiler pressure gauge reads 1.5 bar. Release any air from the pump by slackening the centre screw. Turn off the filling valve (2) and fully close filling valve (1).
- The boiler is equipped with an automatic air release valve. To allow this to vent the boiler, the cap on the top must be slackened by 1-2 turns (This cap must be left slackened during boiler operation to ensure any residual air or system gases are released).
- Check the heating system and boiler connections are sound.

5.5 Initial system flush ("Cold")

The whole of the heating system must be flushed out at least twice: once cold, and once hot as instructed later on page 68. Open all radiator or heating valves and the boiler CH service valves and drain the heating system and boiler completely from the lowest points of the

system via 1/2" BSP drain taps (opened full bore to remove any installation debris prior to lighting the boiler). Refill the heating system. Check the operation of the pressure relief valve by rotating the knob on the valve. Now check the water pressure in the unit again (and add more water if necessary). Close both filling valves and disconnect the temporary connection.

5.6 Filling the heating system (ecoMAX 600)

The boiler and the heating system should be filled using a filling method as described on page 15.

- Ensure that the boiler CH service valves are open.
- Partially open the filling valve and allow water to enter the system. Starting with the lowest radiator, open the radiator air release until water (clear of bubbles) is emitted.
- Repeat this at all radiators until the complete system is full, all air locks have been cleared and the boiler pressure gauge reads 1.5 bar. Release any air from the pump by slackening the centre screw.
- The boiler is equipped with an automatic air release valve. To allow this to vent the boiler, the cap on the top must be slackened by 1 - 2 turns. (This cap must be left slackened during boiler operation to ensure any residual air or system gases are released).
- Check the heating system and boiler connections are sound.

5.7 Initial system flush ("Cold")

The whole of the heating system must be flushed out at least twice: once cold, and once hot as instructed later on page 40.

- Open all radiator or heating valves and the boiler CH service valves and drain the heating system and boiler completely from the lowest points of the system via 1/2" BSP drain taps (opened full bore to remove any installation debris prior to lighting the boiler).
- Refill the heating system.
- Check the operation of the pressure relief valve by rotating the knob on the valve.

5.8 Filling condensate trap

Remove the lower part of the condensate trap (1, fig. 5.1) by unscrewing and fill with water to about 10 mm from the top.

Refit to boiler.

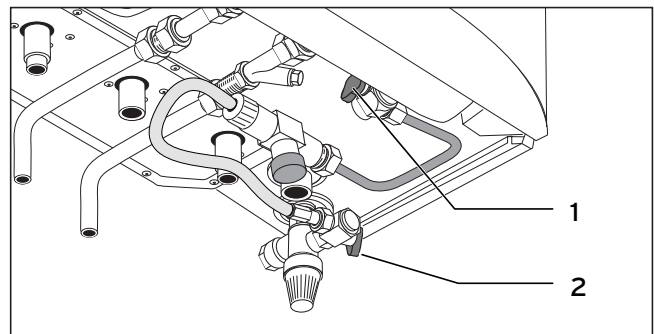

Fig. 5.1 Filling the heating system (ecoMAX 800)

5.9 Adjusting pump speed

5.9.1 ecoMAX 613/2, 618/2, 622/2, ecoMAX 824/2, 828/2

The units are fitted with a two-speed pump. The pump is delivered with the switch (1) set to position III.

Important note (ecoMAX 824/828 only):
 The boiler should only be operated at pump setting III as the heating capacity for hot water is reduced when operated at pump setting II. It is possible, however, to change the pump setting from Level III to Level II manually when there is noise coming from the heating system.

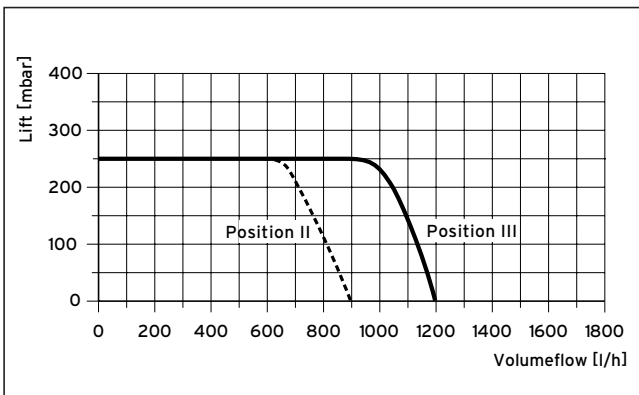

Fig. 5.2 Pump specifications ecoMAX 613/2, 618/2, 622/2, 824/2, 828/2

5.9.2 ecoMAX 635, 835

The ecoMAX 635, 835 are fitted with an automatic modulating pump which regulates according to the resistance of the heating circuit. Within the diagnostic system (see next page) it is possible to preset the pump to five resistance percentage steps up to the maximum available output in 53, 60, 70, 85 and 100 %. Therefore when using this selection option the automatic modulation is switched off.

Note:
 Where a mixing valve is fitted in the heating circuit (underfloor heating circuit) the pump setting in the diagnostic mode (d.14) should be set to 100%.

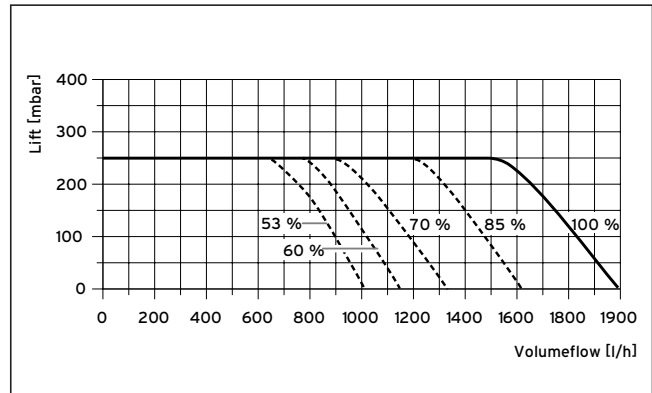

Fig. 5.3 Pump specifications ecoMAX 635, 835

Modulating pump settings (ecoMAX 635, 835 only)

In order to set the pump from modulating to a number of fixed percentage output values, please follow the instruction below.

- Open the appliance to obtain access to the diagnostic display.
- Turn the appliance "on/off"-control to the "I"-position ("on").

- 1 Press the "i" and "+" buttons below the display simultaneously. The display will now show "d.0". Use the "+" button to scroll up to "d.14".

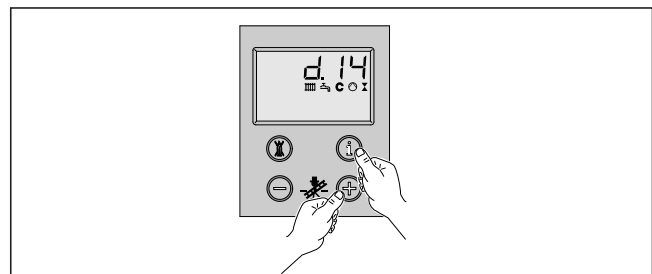

- 2 Press the "i"-button to display the diagnostic information (e. g. factory setting "auto" = pump modulation on).

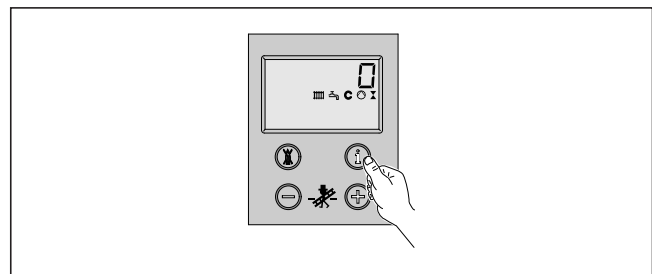

- 3 Press the "+" or "-" button to select the pump resistance value (0 = auto, 1 = 53%, 2 = 60%, 3 = 70%, 4 = 85%, 5 = 100% these figures represent the percentages of the maximum pump output).

5 Commissioning Part I

When altering values the display will flash.

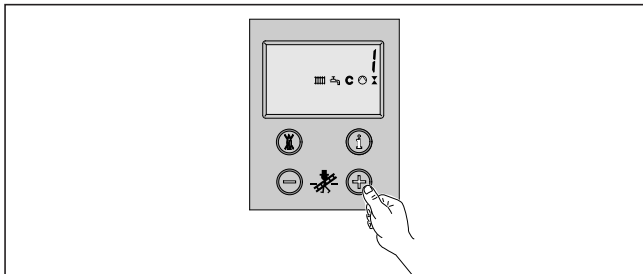

4 Press and hold the "i"-button to save the required value to memory. When the value is saved, the display will stop flashing.

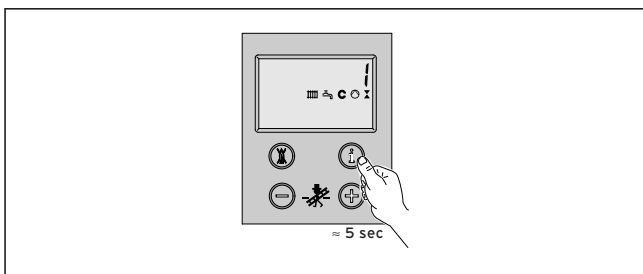

5 Diagnostic mode is cancelled as follows:
Press the "i" and "+"-buttons simultaneously
or Do not press any key for approximately four minutes. The display will now return to its normal state (current heating-system flow temperature, e.g. 45°C).

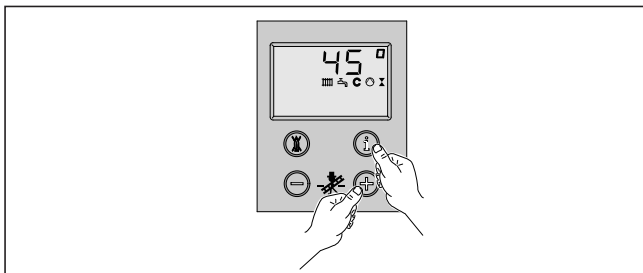

Appliance	Maximum net heat input in kW	Maximum gas rate Natural gas in m ³ /h	Maximum gas rate Propane in kg/h
ecoMAX 613/2 E	13.5	1.43	1.05
ecoMAX 618/2 E	18.4	1.95	1.43
ecoMAX 622/2 E	22.4	2.37	1.74
ecoMAX 635	34.9	3.70	2.70
ecoMAX 824/2 E	23.0	2.43	1.78
ecoMAX 828/2 E	28.0	2.96	2.18
ecoMAX 835 E	35.0	3.70	2.70

Tab. 5.1 Maximum gas rates.

5.10 Checking the gas supply settings

5.10.1 Factory-adjusted gas settings

Caution:
 Before operating the boiler check the data badge and ensure that the correct gas type appliance has been installed.

The boiler is supplied ready adjusted and no further gas adjustments are necessary, however both the gas inlet working pressures and maximum gas rates should be checked as detailed in 5.10.2 and 5.10.3.

5.10.2 Gas inlet working pressure

Check the inlet pressure as described below:

- Remove the front case from the boiler.
- Close the gas shutoff valve fitted to the boiler.
- Loosen the sealing screw marked "in" (1) on the gas valve assembly (Fig. 5.4).
- Connect a digital or a U gauge (2).
- Open the gas shutoff valve fitted to the boiler.
- Put the boiler into service (refer to the Instructions for Use supplied with the boiler).
- Check the U gauge reading and ensure the inlet gas pressure is between the pressures detailed below.

Natural gas:
 DO NOT proceed with adjustment or attempt to put the unit into service if the inlet working pressure lies outside the 17-25 mbar range.

LPG:
 DO NOT proceed with adjustment or attempt to put the unit into service if the inlet working pressure is lower than 37 mbar.

- Turn off the appliance, remove U gauge.
- Tighten the test point screw and test for soundness.
- Record appliance working gas inlet pressure (mbar) in the Benchmark Installation, Commissioning and Service Log Book

5.10.3 Check gas rate

The boiler is fitted with a fully modulating automatic gas valve which ensures that the precise air/gas ratio is provided under all operating conditions.

The gas rate has been set during production and does not require adjustment.

The gas rate of the boiler should be checked with the front case fitted as follows:

- Activate full gas rate mode by simultaneously pressing the "+" and "-" buttons on the display system (ecoMAX 800, fully open the hot water tap to maximum water flow rate).
- Wait at least 5 minutes, or until the boiler has reached its operating temperature
- With all other gas appliances turned off measure the gas rate at the gas meter. Check that the gas rate is as stated in Table 5.1.

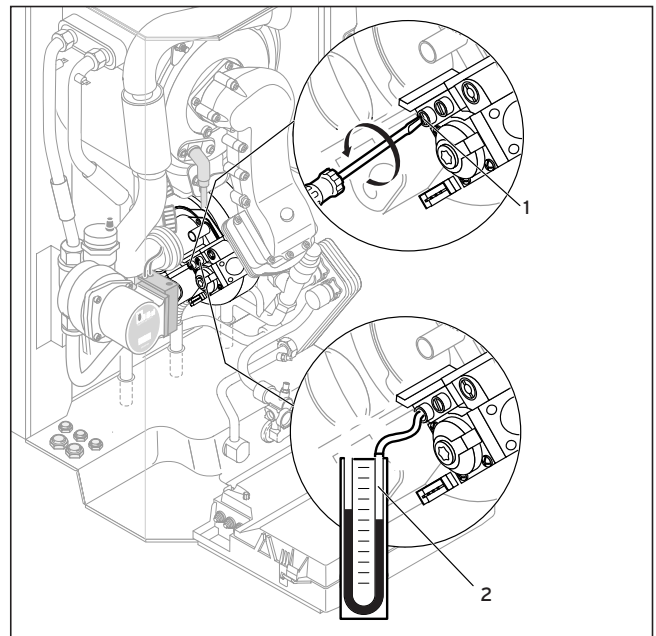

Fig. 5.4 Measuring the inlet working pressure

5 Commissioning Part I

5.11 Refitting the case

Note:
Ensure that the front panel retaining cords are positioned such that they will not become trapped in the casing.

- Hook the top of the front casing (4) over the lip on the top of the boiler chassis and push the bottom of the front casing (3) into place.
- Ensure the spring retaining clips (2) engage correctly.
- Tighten case securing screw (1).

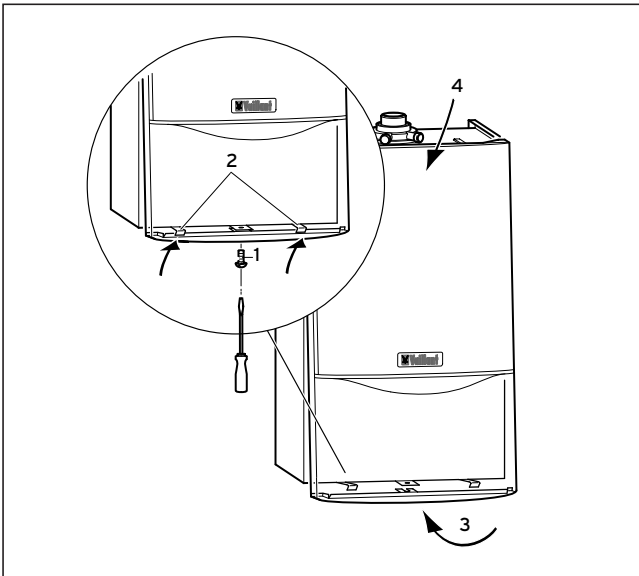

Fig. 5.5 Removing/Refitting the case

5.12 Adjusting the central heating output (range rating)

The boilers are fully modulating for central heating, and it is therefore not necessary to range rate the boiler. However, if desired, it is possible to range rate the boiler, as follows:

- 1 Press the "i" and "+" buttons simultaneously.

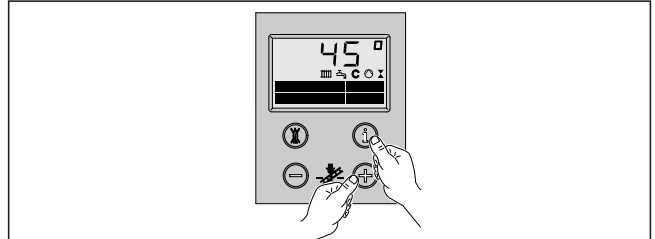
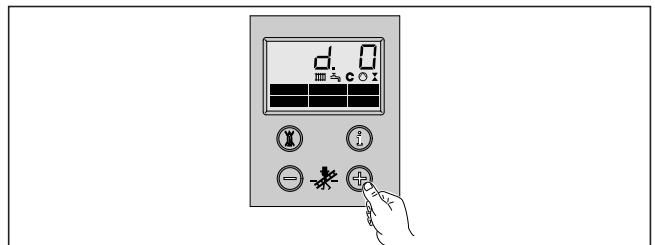
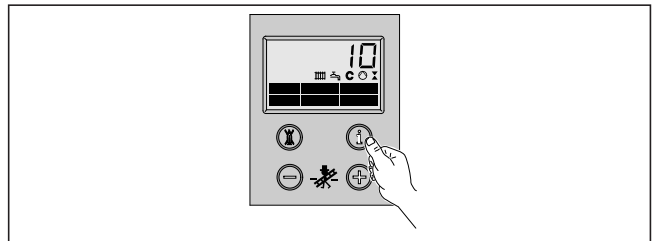

Fig. 5.6 ff Adjusting the central heating output

- 2 Keep the "+" button pressed until "d.0" is displayed. The display runs from "d.0" to "d.99" before restarting at "d.0".



- 3 Press the "i" button. The "=" symbol is displayed. The part-load setting is now displayed in kW.



- 4 Use the "+" and "-" buttons to increase or decrease the value in steps of 1 kW. The displayed value will flash while the adjustment procedure is being carried out. The available ranges of settings are given in Tab. 5.2 on page 39.

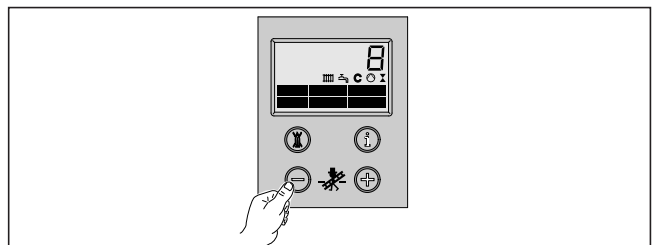

5 Finally, keep the "i" button pressed for about five seconds, or until the display stops flashing. The value is now saved to memory. The display will now return to its normal state (current heating-system flow temperature, e.g. 45 °C).

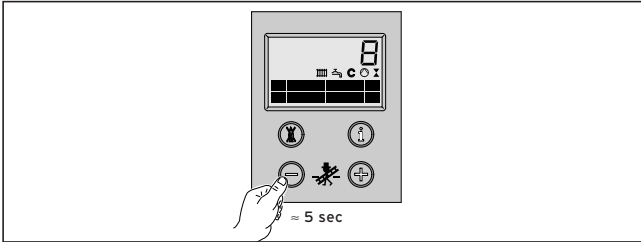

Fig. 5.7 Adjusting the central heating output

6 Press the "i" and "+" buttons simultaneously to cancel adjustment mode. Adjustment mode is also cancelled if no button is operated for a period of 4 minutes.

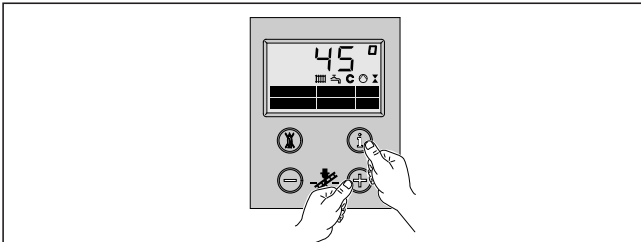

Fig. 5.8 Adjustment of heating system part-load

Appliance	Heating Output in kW
ecoMAX 613/2 E	5 to 14
ecoMAX 618/2 E	11 to 19
ecoMAX 622/2 E	13 to 23
ecoMAX 635	10 to 35
ecoMAX 824/2 E	11 to 19
ecoMAX 824/2 E	13 to 23
ecoMAX 835 E	10 to 27

Tab. 5.2 Heating system part-load adjustment ranges

6 Functional checks (commissioning part II)

6.1 Functional checks

6.1.1 Procedure

Once the unit has been installed and the gas supply has been checked, operate the system to ensure that it is working correctly.

- Operate the system, following the operating instructions supplied with the boiler.
- Check the system for water leaks and escaping gas.
- Check that the flue has been correctly installed, according to the fitting instructions supplied with the flue assembly.
- Check the burner for correct ignition and flame picture.
- ecoMAX 800: Check the hot water system for correct operation.
- Check the heating system for correct operation.

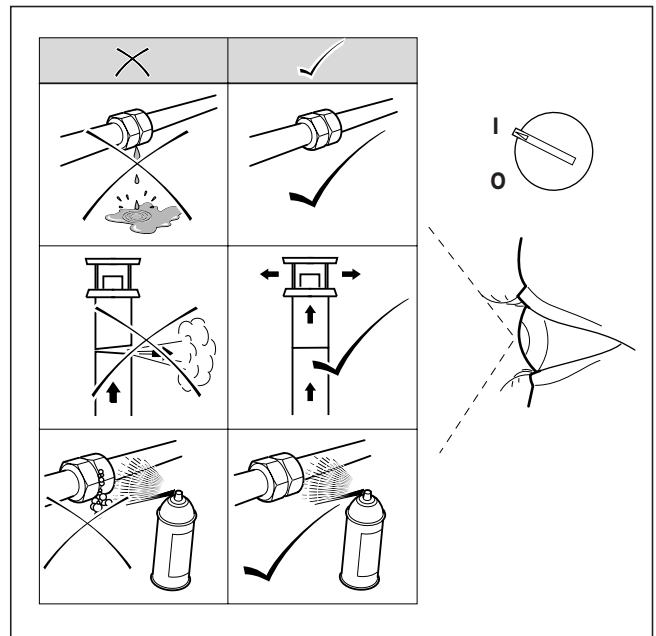

Fig. 6.1 Test for correct functioning

6 Functional checks (commissioning part II)

6.1.2 Hot-water supply (ecoMAX 800)

- Switch the unit on.
- Fully open one of the hot water taps in the system.
- Press the "i" button

Status code "S.14" appears on the display to indicate that the hot-water supply is functioning correctly.

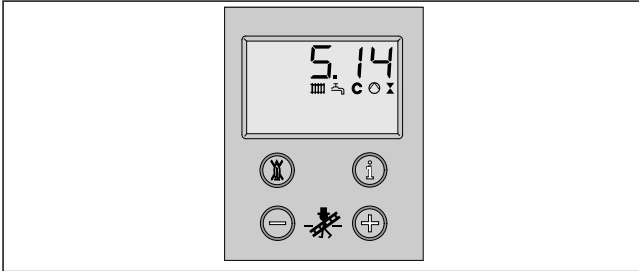

Fig. 6.2 Hot-water supply display messages (ecoMAX 800)

6.1.3 Heating system

- Switch the unit on.
- Ensure that there is a heating demand.
- Press the "i" button.

Status code "S.4" appears on the display to indicate that the heating system is functioning correctly.

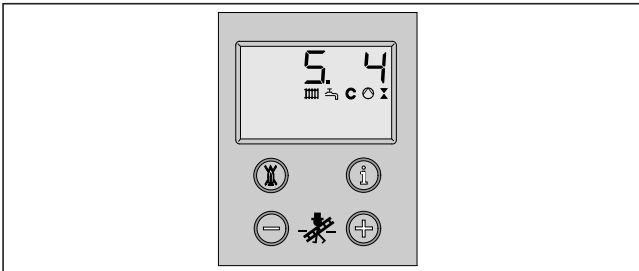

Fig. 6.3 Heating mode display messages

6.1.4 Final system flush ("Hot")

- Turn on the boiler for central heating and allow the boiler and system to reach temperature.
- Check that the heating system is watertight.
- Turn the boiler off and rapidly drain both boiler and system while still hot
- Refill the system and release all air.
- Release water from the system until the system design pressure of 1.0 bar is attained. (The actual reading on the pressure gauge should ideally be 0.5 bar plus an additional pressure corresponding to the highest point of the system above the base of the boiler - 10 m head equals an additional 1 bar reading on the pressure gauge. The minimum pressure should not be less than 1 bar in any installation.) If the system is to be treated with an inhibitor it should be applied at this stage in accordance with the manufacturer's instructions. Further information can be obtained from Sentinel, Betz Dearborn Ltd., Tel: 0151 4951861, or Fernox, Alpha-Fry technologies. Tel: 0870 6015000.
- Disconnect the temporary filling connection.

- Refit the boiler casing.
- Attach the bottom cover to the boiler by sliding the front edge of the cover into the lip at the bottom front edge of the appliance chassis.
- Carefully push the rear of the bottom cover upwards until the spring retaining clips engage at the side of the appliance. It may be necessary to adapt the bottom cover by removing the easy break sections.

6.1.5 Handing over to the user

- Set the maximum radiator temperature control to the desired setting.
- Set the maximum hot water temperature control to the desired setting.
- Instruct the user in the safe and efficient operation of the boiler, in particular the function of
 - the boiler on/off control
 - the maximum radiator temperature control
 - the maximum hot water temperature control (ecoMAX 800)
 - the pressure gauge
- Show the user how to operate any external controls.
- Explain to the user the importance of having the boiler regularly serviced by a competent servicing company. To ensure regular servicing, it is strongly recommended that arrangements are made for a Maintenance Agreement. Please contact Vaillant Service Solutions (0870 6060 777) for further details.
- Record central heating operating pressure in the Benchmark Log Book along with the heat input (kW) and temperature difference between flow and return. Failure to install and commission this appliance to the manufacturers instructions may invalidate the warranty (Note: This does not affect your statutory rights).
- Leave the users instructions, installation instructions and log book with the user.



Danger:

Note that if the boiler is run with an empty condensate trap there is a danger that fumes might escape. Into the room and cause poisoning. For this reason, it is important to ensure that the trap is topped up each time the unit is cleaned.

7. Servicing

7.1 Inspection and servicing

To ensure the continued safe and efficient operation of the boiler it is recommended that it is checked and serviced as necessary at regular intervals. The frequency of servicing will depend upon the particular installation conditions and usage, but in general the boiler should be inspected once per year and serviced every second year. We therefore recommend that a service contract be taken out for the boiler. It is law that all servicing work is carried out by a competent person (CORGI registered).

For safety reasons only genuine Vaillant spare parts should be used when servicing the boiler.

 **Important**
Failure to carry out work in accordance with these instructions could result in personal injury or damage to the property

7.2 Initial inspection

Every year the boiler should be inspected to check its general condition. This inspection should include the boiler, flue, pipework and electrical connections for any indications of damage or deterioration. A gas rate check of the boiler and a visual inspection of the combustion should also be carried out.

Every second year the compact thermal module should be removed and the burner and heat exchanger cleaned.

All inspection and servicing work should be performed in the order as per Table 7.1

No	Description	Inspection	Service
1	Carry out functional check of boiler	X	X
2	Remove the compact thermal module		X
3	Clean primary heat exchanger		X
4	Clean burner		X
5	Refit compact thermal module, replace burner seals (Spare part number 98 1046)		X
6	Check general condition of boiler and clean as necessary	X	X
7	Check electrical plugs and connections	X	X
8	Check/re-pressurise expansion vessel as necessary		X
9	Check and clean condensate trap and connection pipes	X	X
10	Check ignition and burner flame picture	X	X
11	Check boiler for any leaks	X	X
12	Check air/gas flue system	X	X
13	Complete benchmark logbook	X	X

Table 7.1

 **Note:**
The boiler is fitted with a combustion analysis test point. A suitable combustion analyser can

be connected to this point to establish the combustion performance of the boiler.

It is not necessary to check the CO₂ content or adjust the air ratio of the boiler during inspection or annual service.

This value requires checking and adjusting only in the following instances: replacement of gas valve, conversion to or from Natural Gas/ LPG or if incorrect combustion is suspected.

 **Important**
Before starting any maintenance work:

- Isolate the mains electricity supply by disconnecting the plug at the socket outlet (if there is only an isolating switch remove the fuse from the switch).
- Turn OFF the gas supply at the gas service valve fitted to the boiler.
- When removing any water carrying components ensure that water is kept away from all electrical components.
- Always use new seals and O-rings when replacing parts.
- Always test for gas soundness and always carry out functional checks after any service work and after exchanging any gas carrying component.
- Always check earth continuity, polarity and resistance to earth with a multimeter after any service work and after exchanging any electrical component.

Before commencing any servicing or maintenance work, carry out an initial inspection of the system as follows:

- Inspect the flue, pipework and electrical connections for indications of damage or deterioration.
- Inspect the air supply and ventilation arrangements of the installation.
- Check the heating and water system, in particular the condition of radiator valves, evidence of leakage from the heating system and dripping hot water taps.

7.2.1 Removing the compact thermal module

Turn off the boiler

- Isolate the electrical supply to the boiler.
- Remove boiler bottom cover by releasing the two spring retaining lugs and lowering the rear of the bottom cover.
- Gently pull the bottom cover backwards to remove from the appliance. Turn off the gas service valve.
- Turn off the boiler CH service valves.
- Loosen case retaining screw and release the front case spring retaining clips located beneath the front edge of the appliance.
- Remove the front casing by easing forward the bottom edge and gently lifting.
- Lower electronic control box.

7 Servicing

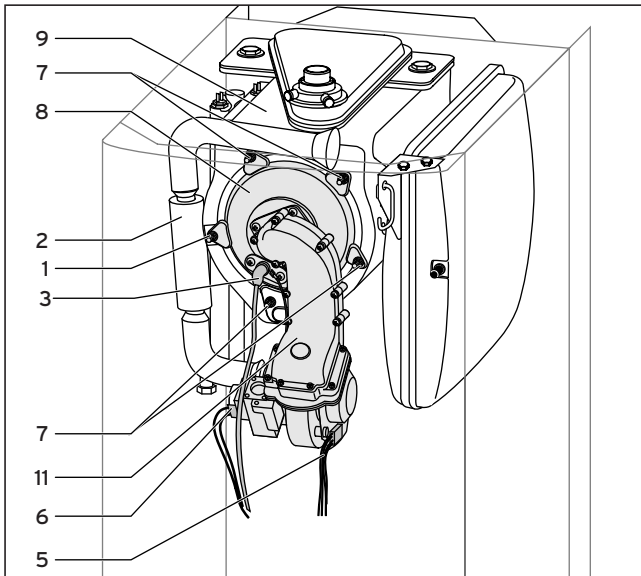

Fig. 7.1 Removing the compact thermal module

Remove burner assembly

- Remove screw (1) and disconnect air inlet pipe (2).
- Disconnect gas supply from gas valve by undoing union (4).

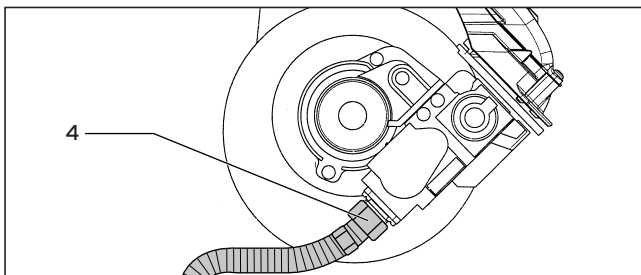

Fig. 7.2 Disconnecting gas supply from the gas valve assembly

- Disconnect HT lead and earth lead (3) from spark electrode.
- Remove five nuts (7) from burner manifold.
- Pull forward complete burner, gas valve and fan assembly.
- Disconnect two electrical connections (5 and 6) from fan and gas valve.
- Remove burner, gas valve and fan assembly (8) from boiler (9).

Note:

The compact thermal module may be very hot and care should be taken when removing the module. The compact thermal module must not be suspended from the corrugated gas tube.

Important:

Under no circumstances should the venturi tube be removed and dismantled from the gas valve as this part is sealed and gas checked during production.

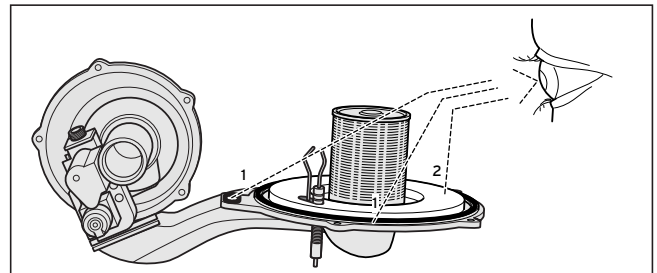

Fig. 7.3 Renewing the seals (1) and checking the burner flange insulation (2)

7.2.2 Inspect main heat exchanger

With the burner and fan assembly removed it is now possible to inspect the main heat exchanger. Remove any loose deposits from the heat exchanger using a soft brush and jet of water (ensure that water is kept away from all electrical components. Any water used to clean the main heat exchanger will drain through the condensate trap).

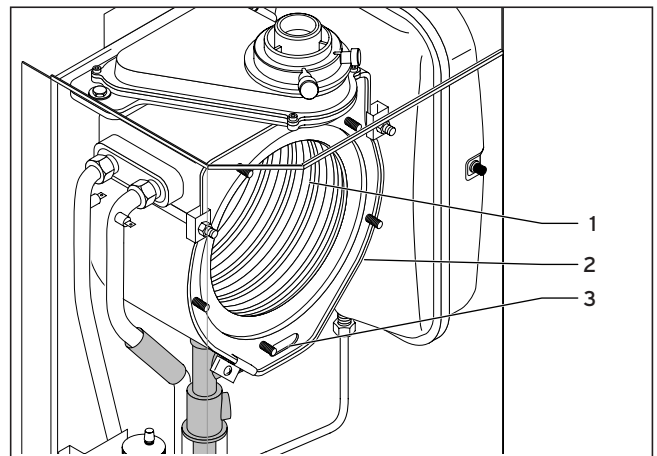

Fig. 7.4 Inspecting the main heat exchanger

7.2.3 Inspect burner

- Visually inspect burner for signs of damage or deterioration.
- Ensure a gap of 4 mm exists between the spark electrode and earth probe.
- Check that the burner manifold sealing gasket is in good condition.
- The burner is maintenance-free and does not require cleaning. The burner must be replaced if its outer surface shows any signs of damage (fig. 7.5).

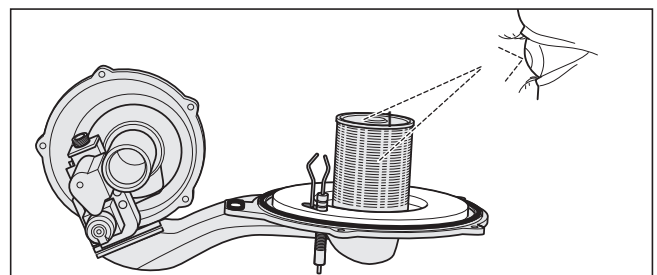

Fig. 7.5 Inspecting the burner

7.2.4 Refitting the compact thermal module

- Renew the silicone gaskets (1) (see Fig 7.3)
- Loosely position the burner, fan and gas valve assembly in place and reconnect the two electrical connections to the fan.
- Refit the burner, fan and gas valve assembly. Ensure that the burner manifold gasket is correctly fitted and that a good seal is obtained.
- Reconnect the gas supply to the gas valve, ensuring that a new sealing washer is used and correctly located.
- Turn on the gas supply and test for soundness.
- Reconnect the HT lead and earth lead to the spark electrode.
- Refit the air inlet pipe.



Danger:

The two silicone seals (1 - fig. 7.3) on the compact thermal module ((SP no. 98-1046) must be replaced each time the module is removed (for example during maintenance). The burner flange insulation (2 - fig. 7.3) on the compact thermal module (SP no. 21-0734) may not show any signs of damage; otherwise it must also be replaced.

7.2.5 Cleaning the condensate trap

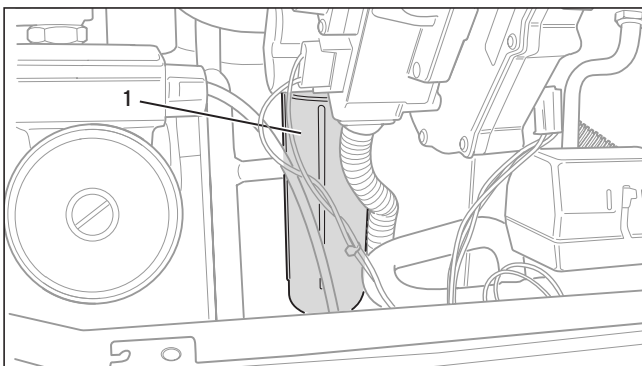

Fig. 7.6 Cleaning the condensate trap

- Unscrew the bottom section (1) of the condensate trap (see fig. 7.6).
- Clean the bottom section of the trap by rinsing it out with water.
- Refill with water to about 10 mm from the top.
- Screw the bottom section back onto the condensate trap.



Danger:

Note that if the boiler is run with an empty condensate trap there is a danger that fumes might escape into the room and cause poisoning. For this reason, it is important to ensure that the trap is topped up each time the unit is cleaned.

7.2.6 Check expansion vessel

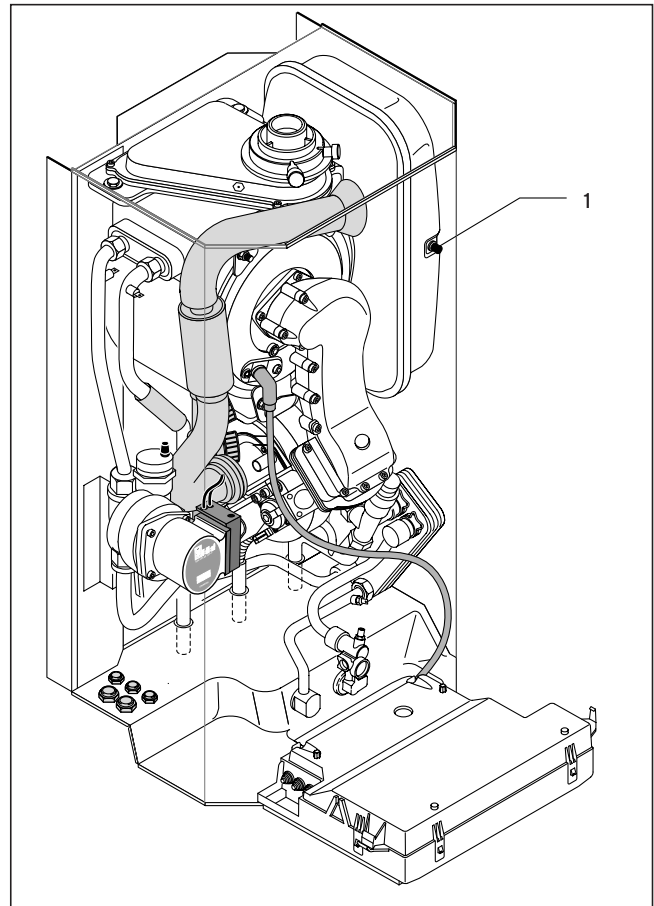

Fig. 7.7 Checking expansion vessel admission pressure



Note:

It is not necessary to perform this check every year - a check every three years is sufficient.

- Ensure the boiler CH service valves are closed.
- Release the pressure from the boiler.
- Remove valve cap from expansion vessel charge point.
- Check that the internal charge pressure of the expansion vessel is between 0.75 and 0.9 bar.
If the pressure is lower than this the vessel should be repressurised using an air pump.
- Refit the valve cap.
- Repressurise boiler and heating system.

7 Servicing

8 Troubleshooting

7.3 Recommissioning the boiler

- Carry out electrical safety checks.
- Turn on the electrical supply.
- Open the boiler CH service valves.
- Carry out function checks of boiler operation as previously detailed.
- Check gas rate as previously detailed.
- Check water soundness.
- Refit case, ensuring that a good seal is obtained.

7.4 Test

Carry out the following checks once the maintenance tasks have been completed:

- Start the unit up according to the instructions supplied with the appliance.
- Check the unit for any signs of escaping gas or water leaks.
- Check the air/flue duct system for leaks and correct attachment.
- Check for excess ignition and ensure that the flame burns regularly and smoothly.
- Check the heating system and hot-water supply for correct functioning.
- Complete the Benchmark log book.

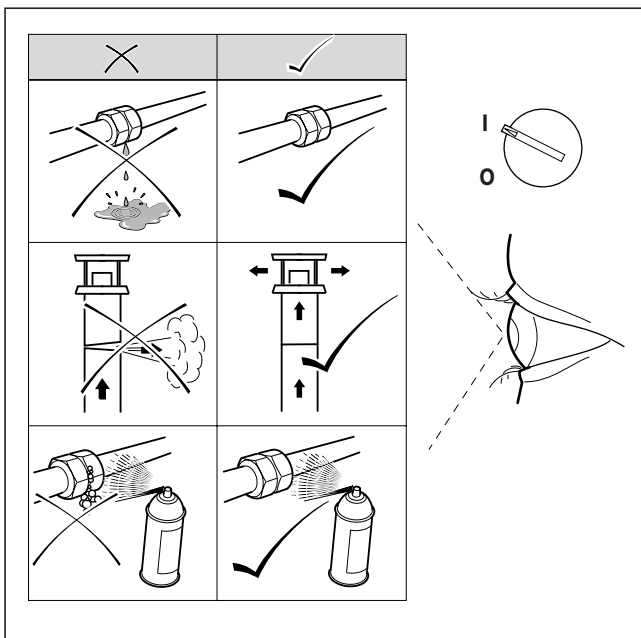

Fig. 7.8 Test for correct functioning

8 Troubleshooting

8.1 Logical fault finding procedure

These checks must be carried out before attempting to use the fault finding guide.

1. Carry out electrical safety checks (See Section 'Preliminary Electrical Checks').
2. Check that the external electricity supply to the boiler is on, and a supply of 230 V~ is present between boiler terminals 'L' and 'N'.
3. Check that the gas supply to the boiler is on, that it has been correctly purged and that an inlet pressure of 20 mbar is available at the gas valve. (See Section 'Gas Supply').
4. Ensure the heating system is full of water and charged to between 1 and 1.5 bar. If not, refill and vent the system. (See Section 'Filling the heating system'). Ensure boiler flow and return service valves are open.
5. Check that the main on/off control is set to the 'on' position.
6. Set the central heating temperature to maximum.
7. Set the domestic hot water temperature to maximum (ecoMAX 800).
8. Check that all external controls are on and calling for heat (if, no external controls are fitted, boiler terminals 3 and 4 must be linked). Check that the boiler anti-cycling economiser is not engaged.

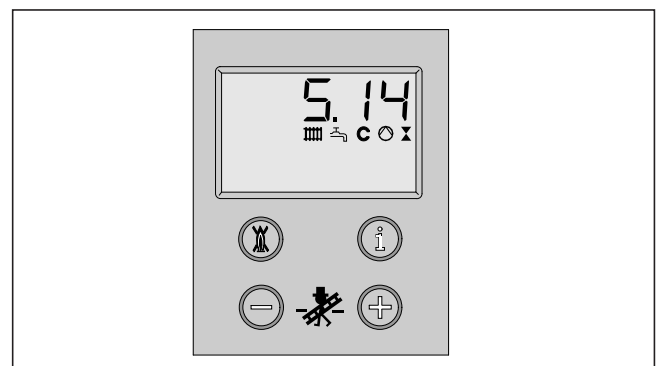

Fig. 8.1 Displaying of status codes

8.1.1 Status mode

The status mode provides information about the current operating status of the boiler.

To display status mode proceed as follows:

- Press the "i" button below the display, and a status code will appear in the display indicating the current operational status of the boiler (see table 8.1).

To cancel the status code mode proceed as follows:

- Press the "i" button below the display or
- Do not press any key for approximately four minutes. The display will now revert back to showing the current flow temperature.

Key to status codes

Code	Meaning	ecoMAX 600	ecoMAX 800
S.0	No heat demand (heating operation)	X	X
S.1	Pump running (heating operation)	X	X
S.2	Pump running - pre ignition (heating operation)	X	X
S.3	Ignition sequence (heating operation)	X	X
S.4	Burner ignited (heating operation)	X	X
S.5	-		
S.6	Heating system fan over run	X	X
S.7	Pump over run (heating operation)	X	X
S.8	Anti cycling mode (heating operation)	X	X
S.10	Hot water demand (hot water operation)		X
S.11	Pump and fan running (hot water operation)		X
S.13	Ignition sequence (hot water operation)		X
S.14	Burner ignited (hot water operation)		X
S.15	-		
S.16	Fan over run (hot water operation)		X
S.17	Pump over run (hot water operation)		X
S.20	Warmstart demand (warm start)		X
S.21	Pump and fan running (warm start)		X
S.23	Ignition sequence (warm start)		X
S.24	Burner ignited (warm start)		X
S.25	-		
S.26	Hot-water fan over run		X
S.27	Pump over run (warm start)		X
S.28	Anti cycling mode (warm start)		X
S.30	No heating demand from external controls	X	X
S.32	Fan unit waiting period	X	X
S.34	Frost protection mode	X	X
S.36	No heating demand from low voltage controls	X	X
S.37	Fan unit waiting period	X	X
S.39	Contact thermostat has been activated (under floor systems)	X	X
S.53	Delay mode due to lack of water in system (~20 mins.)	X	X
S.54	Low water-level waiting period	X	X

Table 8.1 Status codes

8 Troubleshooting

8.1.2 Diagnosis modes

In order to assist with the pinpointing of a particular fault it is possible to use the boiler display in a diagnostic mode to interrogate the boiler about the status of certain components (Table 8.2).

- Press the "i" and "+" buttons below the display simultaneously. The display will now show "d.0".
- Use "+" or "-" buttons to scroll up or down to the desired diagnostic number.
- Press "i" button to display the corresponding diagnostic information.
- If necessary, you can now alter the value by pressing "+" or "-" buttons. (When altering values display will flash). Press and hold the "i" button to save the value to memory, when the value is saved the display will stop flashing.

Diagnostic mode is cancelled as follows:

- Press the "i" and "+" buttons simultaneously or
- Do not press any key for approximately four minutes. The display will now revert back to showing the current flow temperature.

Key to diagnosis codes

Code	Meaning	Displayed/Adjustable values
d.0	Part load setting	Adjustable values in kW
d.1	Water pump over run	1 - 60 min (factory-adjusted to 5 min)
d.2	Maximum burner anti cycling period at 20 °C flow temperature	2 - 60 min (factory-adjusted to 20 min)
d.5	Flow temperature setting	Target value in °C
d.7	Warmstart temperature setting (ecoMAX 800)	Target value in °C
d.8	External controls heat demand	0 = room thermostat open (no demand) 1 = room thermostat closed (demand)
d.i0	Pump status	1 = ON 0 = OFF
d.i1	External pump status	1 = ON 0 = OFF
d.i3	External circulation pump when fitted (ecoMAX 835)	1 = ON 0 = OFF
d.i4	Pump speed (ecoMAX 635, 835)	Set value for built-in pump. Factory setting: "auto"; possible adjustments: 0 = auto, 1 = 53%, 2 = 60%, 3 = 70%, 4 = 85%, 5 = 100%
d.i6	2 nd pump	1 = DHW circulating pump 2 = external CH pump 3 = vantage loading pump 4 = solar pump
d.22	Domestic hot water demand	1 = ON 0 = OFF
d.23	Summer/Winter function (control knob)	1 = Winter 0 = Summer
d.24	Not applicable in GB	-
d.25	Hot-water activation via warm-start clock	1 = yes 0 = no
d.34	Current fan speed value	Current value in rpm/10
d.35	Diverter valve position (ecoMAX 800)	0 = heating system 1 = hot water 2 = mid position
d.40	Actual flow temperature	Current value in °C
d.41	Actual return temperature	Current value in °C
d.44	Actual ionisation-current value	Current value /100 in →A
d.46	Outside-temperature correction (only when VRC 410s is fitted)	Correction value in K
d.47	Actual outside temperature (only when VRC 410s is fitted)	Current value in °C
d.60	Number over heat cut off operations	Number
d.61	Number of lock outs	Number of unsuccessful ignition operations at last attempt
d.67	Remaining anti cycling period	in min
d.68	No first start	Number of unsuccessful attempted 1 st ignitions
d.69	No second start	Number of unsuccessful attempted 2 nd ignitions
d.71	Maximum target value for heating system (ecoMAX 800) (factory-adjusted to 75 °C)	Max. target value for heating-system flow temp. flow temperature adjustable value 40-85 °C
d.72	Pump over run (for loading warmstart) (ecoMAX 800) warm-start and filling via C1- C2); factory-adjusted to 80 s	Pump over run period, in seconds, after filling of an electronically-controlled hot-water tank (incl.
d.73	Offset warmstart temperature value For solar applications: Switching difference for the solar pump	Range: -15 K to +15 K Factory-adjusted to -5 K (ecoMAX 800). Recommended setting for solar applications: +7 °C
d.80	Number of heating system operating hours (Total) (ecoMAX 800)	in h
d.81	Number of hot water system operating hours (Total) (ecoMAX 800)	in h
d.82	Number of heating system cycles (Total)	
d.83	Number of hot water system cycles (Total)	

Table 8.2 Diagnosis codes

8 Troubleshooting

8.1.3 Fault codes

Fault codes take priority over all other display functions in the event of a system fault occurring (Table 8.3). If multiple faults occur, the corresponding fault codes are displayed alternately for about two seconds each.

8.1.4 Fault memory

The fault memory stores details of the ten most recent faults.

- Press the "i" and "-" buttons simultaneously.
- Use the "+" button to scroll back through the list of memorised errors.

To cancel fault error memory display mode, proceed as follows:

- Press the "i" button below the display or
- Do not touch any key for about four minutes. The display will now revert back to showing the current flow temperature.

Key to Fault codes

Code	Meaning	Cause
F.0	Flow-NTC: - NTC broken - NTC cable broken - Defective connection at NTC - Defective connection at electronics	Flow-NTC cable defective/broken NTC faulty
F.1	Return-NTC: - NTC broken - NTC cable broken - Defective connection at NTC - Defective connection at electronics	Return-NTC cable defective/broken NTC faulty
F.10	Short circuit - flow-NTC (< 130 °C)	NTC- plug shorted to casing, NTC defective
F.11	Short circuit - return-NTC (< 130 °C) NTC defective	NTC- plug shorted to casing
F.13	Short circuit in tank sensor	NTC defective, earth leak/short circuit in cable loom, damp plug connection
F.20	Over heat cut off activated	Maximum temperature exceeded
F.22	Low water or no water in appliance	No water in system Pump defective Pump lead defective
F.23	Water level low Temperature range too wide	Pump obstructed, pump running at lower capacity, Air in appliance, system pressure too low, flow and backflow NTC reversed
F.24	Water level low Temperature rises too fast	Pump obstructed, pump running at lower capacity, ir in appliance, system pressure too low, flow and backflow NTC reversed
F.25	Water Switch System pressure too low	Water Switch - plug disconnected Waterswitch activated
F.27	No demand to gas valve	Electronic board defective Gas valve defective
F.28	Boiler goes to lock out	No gas Insufficient gas Incorrect gas valve adjustment Electrode defective Ignition lead defect Electronic igniter defective Check air inlet duct
F.29	Flame extinguished re-ignition unsuccessful	Gas supply absent or insufficient Check flue duct
F.32	Fan turning-speed malfunction (too fast at start-up)	Fan unit obstructed, plug-in fan connector not correctly inserted, Hall sensor defective, fault in cable loom, defective electronic control system
F.60	Gas-valve control + defective	Short circuit/earth (ground) leak in cable loom to gas valves, gas valve assembly defective (earth/ground leak from coils), electronic control system defective
F.61	Gas-valve control - defective	Short circuit/earth (ground) leak in cable loom to gas valves, gas valve assembly defective (earth/ground leak from coils), electronic control system defective
F.62	Defective gas-valve closure mechanism	Leak in gas valve assembly, electronic fault
F.63	EEPROM error	Electronic fault
F.64	Electronic system/sensor fault	Short circuit in flow or backflow NTC, electronic fault
F.65	Electronic system temperature too high	Electronic system affected by external heat source, electronic fault
F.67	Electronic fault in flame system (non-plausible flame signal)	Electronic fault

Table 8.3

8 Troubleshooting

8.2 Test programs

The use of different test programs permits the activation of a range of special unit functions. Please refer to Table 8.4 (below) for detailed information.

- Test programs P.1 to P.6 are activated by operating the Power ON switch and pressing the "+" button at the same time (and keeping it pressed for five seconds). "P.1" will now appear on the display
- Press the "+" button to increase the test number
- Now press the "i" button to start up the unit and activate the test program
- Test programs can be aborted by pressing the "i" and "+" buttons at the same time. Test programs are also cancelled if no button is operated for 15 minutes.

Display	Meaning
P.1	Test program used when the unit runs at full load after successful ignition
P.2	Test program used when the unit runs with minimum gas consumption after successful ignition
P.3	not applicable
P.4	not applicable
P.5	Program for STB (safety temperature limiter) testing; the device heats up, bypassing the regulator shutdown procedure, until it reaches the STB shutdown temperature of 97 °C
P.6	not applicable

Table 8.4 Test programs

9 Parts replacement

Ensure that ALL regulations are observed.

9.1 Safety instructions

The following safety instructions are to be followed when installing replacement parts!

Important:
 Before starting any maintenance work: Isolate the mains electricity supply by disconnecting the plug at the socket outlet (if there is only an isolating switch remove the fuse from the switch).

- Turn off the gas supply at the gas service valve fitted to the boiler.
- When removing any water carrying components ensure that water is kept away from all electrical components.
- Always use new seals and O-rings when replacing parts.
- Always test for gas soundness and always carry out functional checks after any service work and after exchanging any gas carrying component.
- Always check earth continuity, polarity and resistance to earth with a multimeter after any service work and after exchanging any electrical component.

9.1.1 Initial preparation

- Turn off the boiler.
- Isolate the electrical supply to the boiler.
- Remove boiler bottom cover.
- Turn off the gas service valve.
- Turn off the boiler CH service valves.
- Turn off the cold water inlet service valve (ecoMAX 800).
- Remove front case
- Lower electronic control box.
- Release central heating water pressure by draining the boiler from the drain points provided. (This needs only to be carried out when detailed in these instructions).
- After installing replacement parts, recommission and check boiler function as described in commissioning section.

Note:
 The boiler is fitted with a combustion analysis test point. A suitable combustion analyser can be connected at this point to establish the combustion performance of the boiler.

9.1.2 Removal of burner assembly

- Remove screw and disconnect air inlet pipe.
- Disconnect gas supply from gas valve by undoing union.
- Disconnect HT lead and earth lead from spark electrode.
- Remove five nuts from burner manifold.
- Disconnect two electrical connections from fan and gas valve.
- Pull forward complete burner, gas valve and fan assembly.
- Remove burner, gas valve and fan assembly from boiler.

9.2 Replacement of burner

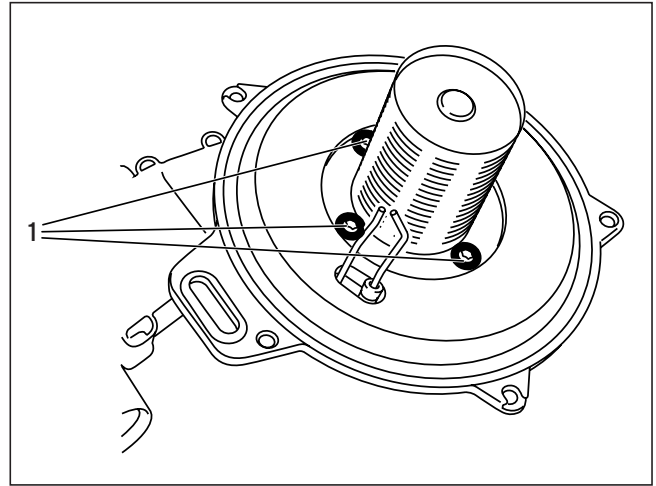

Fig. 9.1 Replacing the burner

- Turn off boiler.
- Remove front casing.
- Lower control box.
- Remove burner, gas valve and fan assembly as previously detailed.
- Remove 4 screws (1) securing burner to burner manifold.
- Fit new burner to manifold using the new sealing gasket supplied, ensuring that the notch in the burner aligns with the burner viewing window.
- Reassemble in reverse order.
- Recommission boiler as detailed.

9.3 Replacement of fan

- Turn off boiler.
- Remove front casing.
- Lower control box.
- Remove burner, gas valve and fan assembly as previously detailed.
- Remove 4 screws (1).
- Separate gas valve and fan assembly from burner manifold (2).
- Remove 2 screws (3) securing gas valve to fan.
- Fit gas valve to new fan using the new sealing gasket supplied.
- Refit gas valve and fan assembly to burner manifold using the new sealing gasket supplied. Equally tighten the four screws (1) to ensure a good seal is made.
- Reassemble burner, gas valve and fan assembly in reverse order.
- Recommission boiler as previously detailed.

9 Parts replacement

9.4 Replacement of gas valve

- Turn off boiler.
- Remove front casing.
- Lower control box.
- Remove burner, gas valve and fan assembly as previously detailed.
- Remove 4 screws (1).
- Separate gas valve and fan assembly from burner manifold (2).
- Remove 2 screws (3) securing gas valve to fan.
- Disconnect gas inlet supply connection from gas valve by removing four screws. Refit the gas inlet supply connection to the new gas valve using the new sealing gasket supplied.
- Fit new gas valve to fan using the new sealing gasket supplied.
- Refit gas valve and fan assembly to burner manifold using the new sealing gasket supplied. Equally tighten the four screws (1) to ensure a good seal is made.
- Reassemble burner, gas valve and fan assembly in reverse order.
- Recommission boiler as previously detailed. Ensure combustion analysis is carried out after part replacement as detailed in section 9.8.

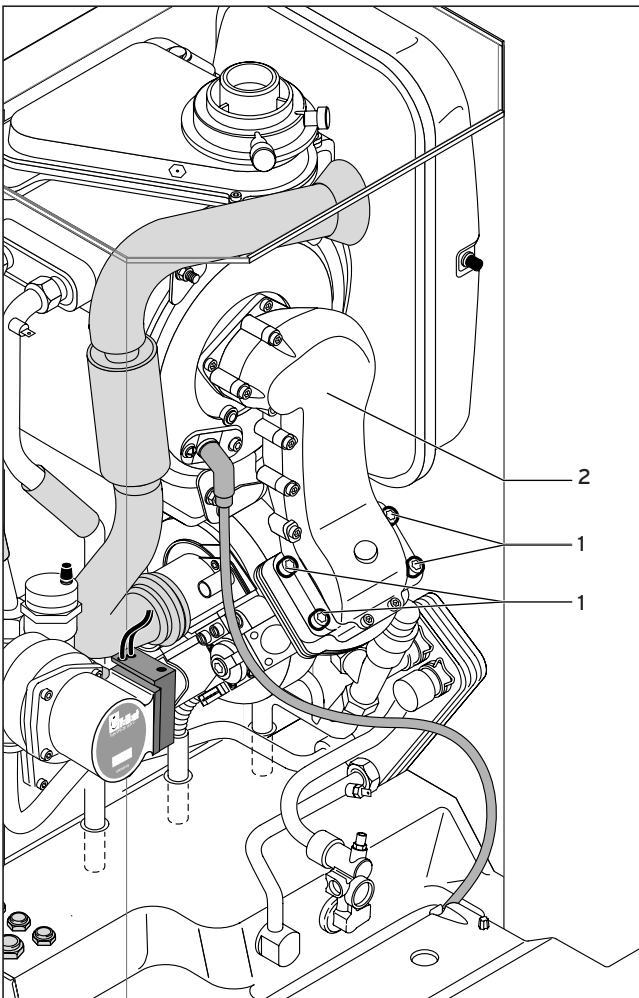

Fig. 9.2 Replacing the gas valve

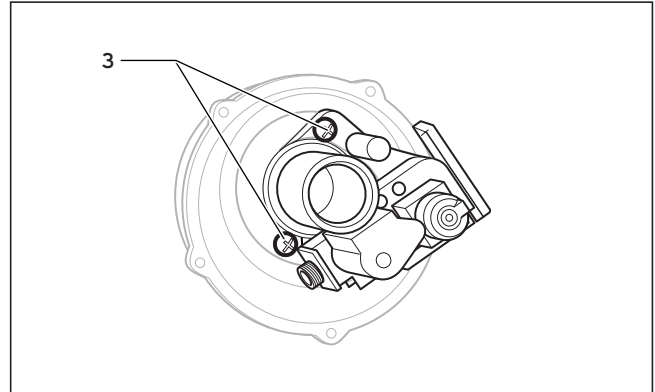

Fig. 9.3 Gas valve

9.5 Replacement of central heating expansion vessel

- Turn off boiler.
- Remove front casing.
- Lower control box.
- Drain boiler as previously described.
- Disconnect union (1) from expansion vessel.
- Remove two screws (2) and remove retaining bracket (3).
- Slide the expansion vessel forward to remove from the boiler.
- Reassemble in reverse order.
- Recommission boiler as previously detailed.

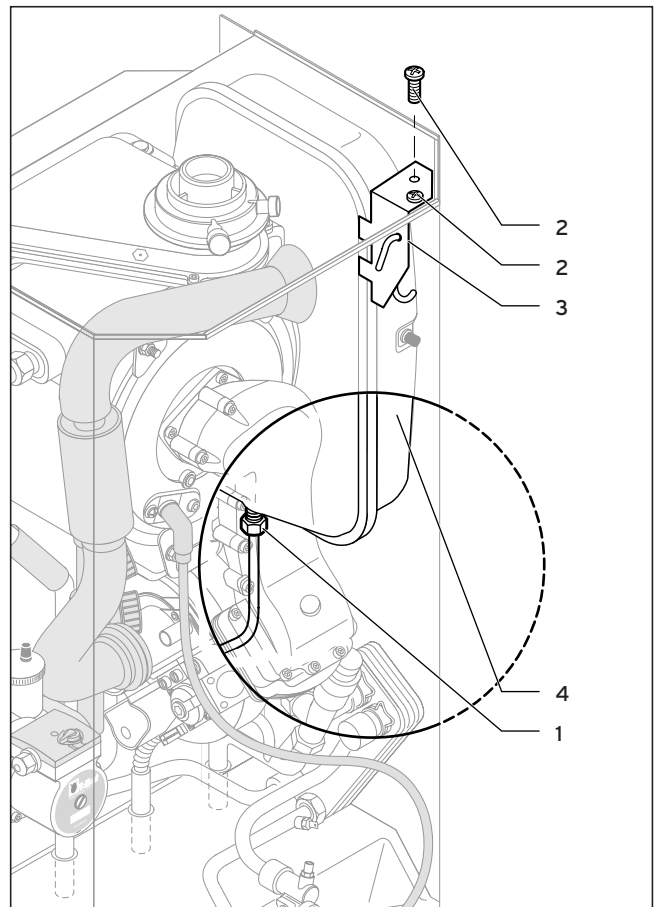

Fig. 9.4 Replacing the expansion tank

9.6 Replacement of main heat exchanger

- Turn off boiler.
- Remove front casing.
- Lower control box.
- Drain boiler as previously described.
- Remove burner, gas valve and fan assembly as previously detailed.
- Disconnect condensate drain by removing spring clip (4) and pulling condensate drain (5) downwards.
- Disconnect primary flow connection (7) from main heat exchanger. (A flexible connection has been provided in the flow pipe to allow easier access to the return connection. The flow pipe can be carefully eased out of the way by bending at the flexible connection).
- Disconnect primary return connection (6) from main heat exchanger.
- Loosen nylon nut at bottom of heat exchanger.
- Slacken the two top securing bolts (8) and rotate clamps away from heat exchanger.
- Fully remove bottom screw and securing clamp (8).
- Pull heat exchanger forwards to remove from the boiler.
- Drain any residual water from the heat exchanger.
- Reassemble in reverse order.
- Recommission boiler as previously detailed.

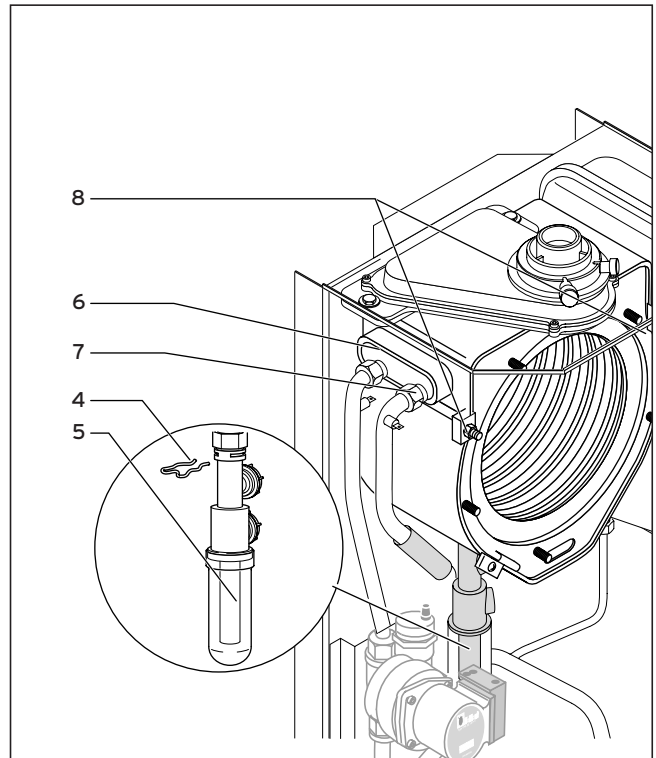

Fig. 9.6 Replacing the main heat exchanger

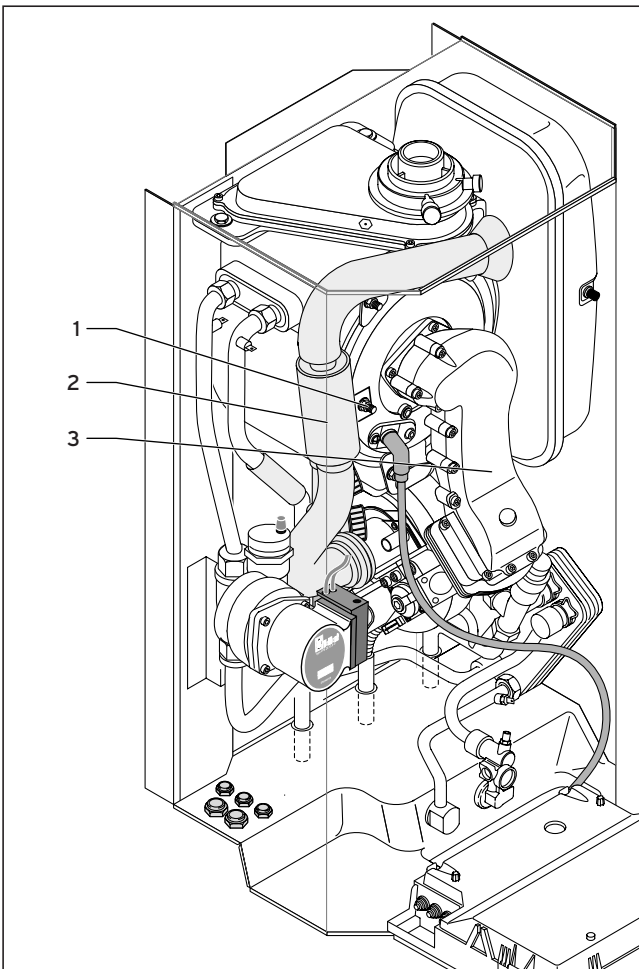

Fig. 9.5 Replacing the main heat exchanger

9 Parts replacement

9.7 Replacement of the electronic control board



Danger:

Ensure you observe the safety precautions when replacing this component.

- Turn off boiler.
- Remove front casing.
- Lower control box.
- Unclip the back cover from the electronics box and open the cover.
- Unclip the front cover from the electronics box and remove the cover.
- Disconnect all wires from the circuit board.
- Unclip the circuit board and remove.
- Remove the display unit and (if fitted) the built-in timer from the electronics box.

- Clip the new circuit board into position in the electronics box, reconnect all plug-in wires and refit back cover of the switch box by clipping the cover back into position.
- Raise the electronics box and reinstall the display unit and (if fitted) the built-in timer. The display unit and built-in timer are connected using the contact pins on the circuit board.
- Recommission boiler as previously detailed.

The new circuit board must be adapted to the heating unit and its system. To do so, carry out the adjustments to the display system of the heating unit as shown in Tab. 9.1.



Note:

The values in Tab. 9.1 that appear in bold script MUST be adjusted. All other values can be adjusted as required, or the circuit board default values can be retained

Code	Meaning	Displayed/Adjustable values	Circuit board setting (default)	Setting for ecoMAX 600	Setting for ecoMAX 800
d.0	Heating system part load	Adjustable values in kW	45 kW	system-dep.	system-dep.
d.1	Heating system pump over run	1 - 60 min	5 min	system-dep.	system-dep.
d.2	Heating system max. off-period	1 - 60 min	20 min	system-dep.	system-dep.
d.14	Pump speed	Set value for built-in pump 0 (= auto), 53, 60, 70, 85, 100 %	0 = (auto)	system-dep.	system-dep.
d.16	External CH pump	1, 2, 3, or 4	1	-	2
d.71	Max. target value for heating-system flow temperature	40 - 85 °C	82 °C	system-dep.	system-dep.
d.72	Hot-water pump over run	0 - 250 s	80 s	system-dep.	system-dep.
d.73	Difference between warm start and hot-water outlet target value	-15 K to +15 K	-9K	-	-

Tab. 9.1 Values to be programmed in after installation of a new circuit board

9.8 Check CO₂ content and adjust if necessary (air-ratio adjustment)



Note:

Checking/adjustment of this value is required in the following instances: replacement of gas valve, conversion to or from Natural Gas/ LPG or if incorrect combustion is suspected!

- Remove the case from the unit.
- Activate full gas rate mode by simultaneously pressing the "+" and "-" buttons on the display system (ecoMAX 800, fully open the hot water tap to maximum water flow rate).
- Wait at least five minutes, or until the unit has reached its operating temperature.
- Measure the level of CO₂ content at the exhaust-fume test outlet (3) (Fig. 9.12). Check the reading against the corresponding value in tab. 9.2.

- If the exhaust-fume setting requires adjustment, remove the screw (4) and swivel the air suction pipe (5) forwards through 90° (Fig. 9.12). DO NOT remove the air suction pipe.
- Adjust the corresponding setting as required (see Table 5.2, p. 39) by turning the screw (6) (see Fig. 9.13).



Natural gas:

Adjust in steps of no more than 1/8 of a turn, and wait for each new value to stabilise (about one minute).



LPG:

Adjust in small steps of no more than 1/16 of a turn, and wait for each new value to stabilise (about one minute).

- Turn anti-clockwise to increase level of CO₂ content.
- Turn clockwise to reduce level of CO₂ content.
- Once the adjustment procedure is complete, swivel the air suction pipe upwards and back into position.
- Re-check the level of CO₂ content.
- The adjustment procedure may have to be repeated.
- Press the "+" and "-" buttons simultaneously to deactivate full gas rate mode. Measurement mode is also cancelled if no control button is operated for 15 minutes.
- Reposition air suction pipe and tighten screw (4).
- Raise control panel.

Adjustment settings	Natural gas (H)	Propane Tolerance	Unit Tolerance
CO ₂ after 5 min. operation at full load	9,0 ± 1,0	10,0 ± 0,5	Vol.-%
Adjusted for Wobbe index Wo	15	22,5	kWh/m ³

Tab. 9.2 Factory-adjusted gas settings

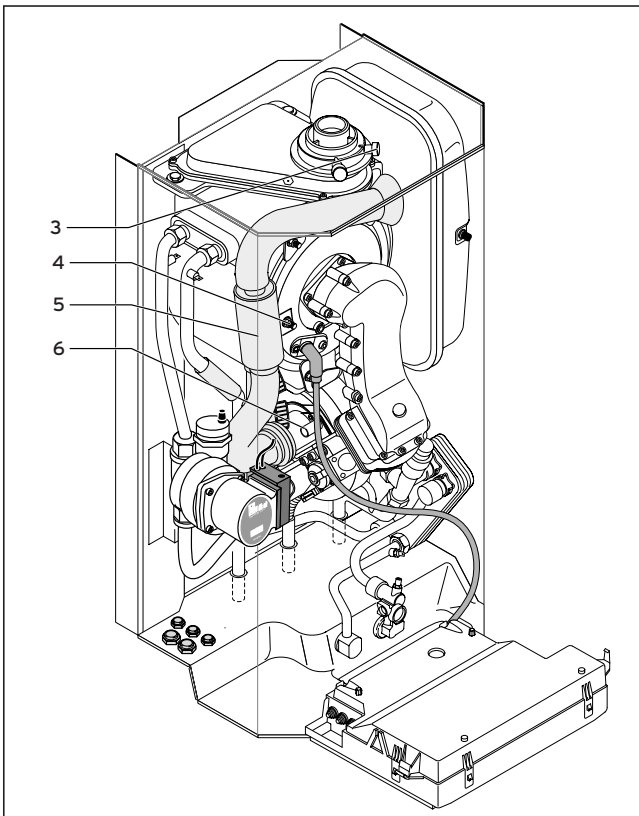

Fig. 9.12 Carrying out measurement of CO₂ levels, preparing for air-ratio adjustment

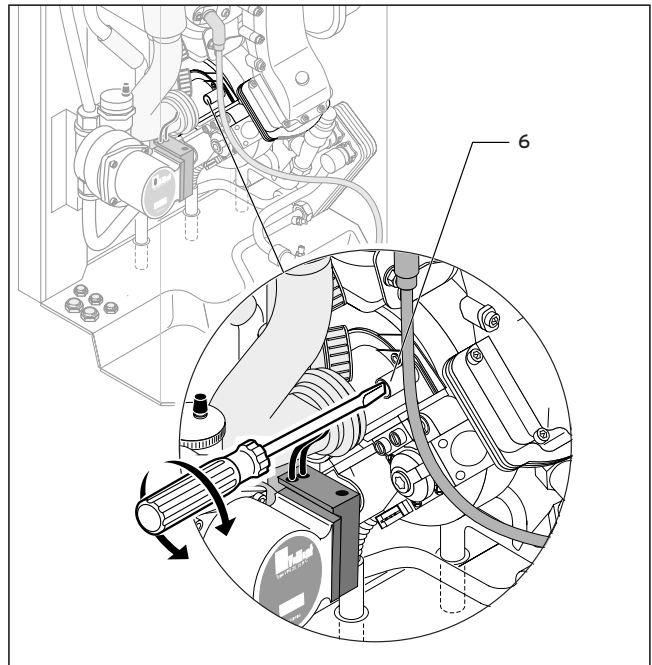

Fig. 9.13 Carrying out air-ratio adjustment (gas supply settings)

10. Recycling and eventual scrapping

The design of all Vaillant products takes into account the subsequent recycling and/or eventual safe scrapping of each component used. Vaillant's in-house rules set strict standards in this respect. The selection process used for choosing raw materials includes full consideration of their recycling characteristics, and of the breakdown and separation properties of subassemblies. We also take fully into account the environmental and health hazards involved in recycling and in the disposal of non-reusable waste items.

10.1 The appliance

The Vaillant ecoMAX consists largely (92 %) of metal components designed for eventual recycling by incorporation into the smelting process of a steelworks. This gives these parts virtually unlimited scope for subsequent re-use. All plastic materials are duly identified to facilitate sorting and separation when the time comes to recycle the unit.

10.2 Packing

Vaillant endeavours to keep the amount of transport packaging used for its equipment to the bare minimum necessary. Subsequent re-use is taken into account when selecting packaging materials. High-quality cardboard has long been a valuable secondary raw material for the card and paper industry. The sections of EPS (Styropor®) are required in order to protect equipment in transit. EPS is 100 % recyclable and CFC-free. The foil-wrapping and securing straps are likewise made of recyclable plastic.

Vaillant Ltd

Vaillant House ■ Medway City Estate ■ Trident Close ■ Rochester ■ Kent ME2 4EZ
Telephone 01634 292300 ■ Fax 01634 290166 ■ www.vaillant.co.uk ■ info@vaillant.co.uk