

**REZMOR<sup>®</sup>**

**RADIANT  
HEATER  
CATALOG**

**Form C-IR (Version D)**

## BACKGROUND

Reznor was founded in 1888 to manufacture the “Reznor” reflector heater, which used a luminous flame gas burner developed by George Reznor. This technological breakthrough was an immediate success and hastened the expansion of gas heating in residential and commercial applications. Technological development and innovation have been the hallmark of Reznor products through the years. The development of the forced air gas unit heater, the modular Thermocore® heat exchanger, and the high-efficiency, sealed-draft Venturion® unit heater have kept Reznor products at the forefront of technological advances in commercial and industrial gas heating. As a result of this pioneering role in the heating, makeup air, and ventilating equipment field, the products offered today are the most advanced in engineering design to satisfy a wide variety of applications.

## FACILITIES

Reznor heaters were first manufactured and sold in Mercer, Pennsylvania (70 miles north of Pittsburgh) in 1888. Over the years, the company has grown and expanded. Today, with sales worldwide, Reznor products are being manufactured at six different facilities throughout North America and Europe.

## PRODUCT SCOPE

Well-equipped engineering laboratories for both product development and testing can be found at many of the manufacturing sites. All domestic lab sites are agency approved.

Reznor Products include a complete line of heating, makeup air and ventilating systems, using gas, oil, hot water/steam, or electric heat sources. Reznor heater catalogs are designed to aid the engineer, architect or contractor in specifying the correct equipment for all standard and special applications. Complete data is presented on unit heaters, duct furnaces, infrared heaters, makeup air systems, pre-engineered custom-designed systems, and evaporative cooling modules. Consult your local Reznor Sales Representative for further assistance in specifying Reznor Equipment for your specific application.

## SERVICES

Product service requirements are handled through contractors and/or distributors, with backup from local representatives and factory-based service team. Replacement parts inventories for both warranty and non-warranty requirements are maintained at service centers throughout the country and at the manufacturing facilities.

For the Reznor Representative in your area, call 800-695-1901.

# REZNOR®

# Infrared Heating Catalog

## Low-Intensity Infrared

Model VR - Modular Tubular Radiant Heater



## TABLE OF CONTENTS

Page No.

### LOW INTENSITY INFRARED

#### Model VR

Description/Standard Features/Optional Features .....	2
Technical/Dimensional Data .....	3
Reflector End Covers/Side Shields .....	3
Dimensions .....	4
5 Foot Heat Exchanger .....	4
Venting Requirements & Outside Air Combustion .....	5
Heater Configurations .....	7
Clearance to Combustibles .....	8
Location and Mounting Height .....	8
Installation/Assembly .....	9
Packaging Scheme .....	10
Sample Specifications .....	11
Warranty .....	11

## High-Intensity Infrared

Model RIHN/RIHVN/RIHL/RIHVL - Surface Combustion Radiant Heaters



### HIGH INTENSITY INFRARED

#### Models RIHN/RIHVN/RIHL/RIHVL

Description/Standard and Optional Features .....	12
Technical/Dimensional Data .....	13
Mounting Location/Installation/Coverage .....	14
Chain Hanging Kit .....	15
Sample Specifications .....	16
Warranty .....	16

**NOTE:** Due to continuing design improvements, all specifications in this catalog are subject to change without notification. These heaters are not approved for residential use.

**WARNING:** Improper installation, adjustment, alteration, service or maintenance can cause property damage, injury or death. Read the installation operation and service/maintenance manual thoroughly before servicing or servicing this equipment.

Gas-fired appliances are not designed for hazardous atmospheres containing flammable vapors or combustible dust, or atmospheres containing chlorinated or halogenated hydrocarbons.

**For your safety:** The use and storage of gasoline or other flammable vapors and liquids in the vicinity of this appliance is hazardous.

Installations must be in accordance with enforcing authorities, the National Fuel Gas Code NFPA 54/ANSI Z223.1 (latest edition) in the United States, and the Natural Gas and Propane Installation Code CAN/CSA-B149.1 (latest edition) in Canada. In addition installations must meet NFPA 88A (latest edition) for parking structures, NFPA 88B (latest edition) for repair garages, and NFPA 409 (latest edition) for aircraft hangars.

**NOTE:** Reznor infrared heaters are not approved for residential use.

**IMPORTANT:** Specifications are subject to change without notice. This guide is intended to provide specifications and technical information only.

This guide is not intended to be an instruction manual. When installing heating and ventilating equipment, you must check and conform to all local and national building codes. Improper installation of heating and ventilating equipment could be dangerous. Consult manufacturer's installation manual for instructions and important warnings.

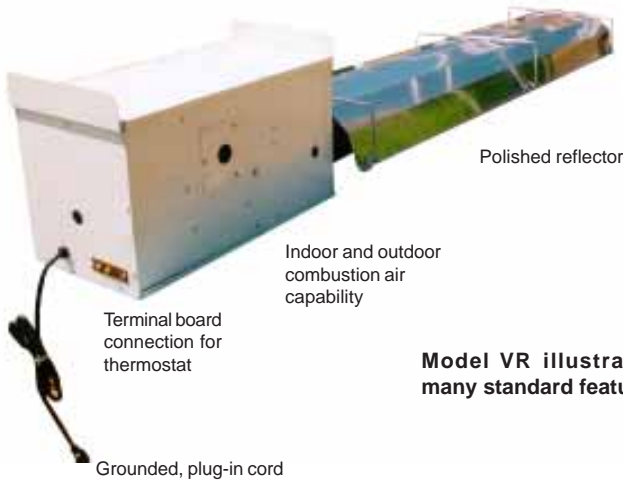
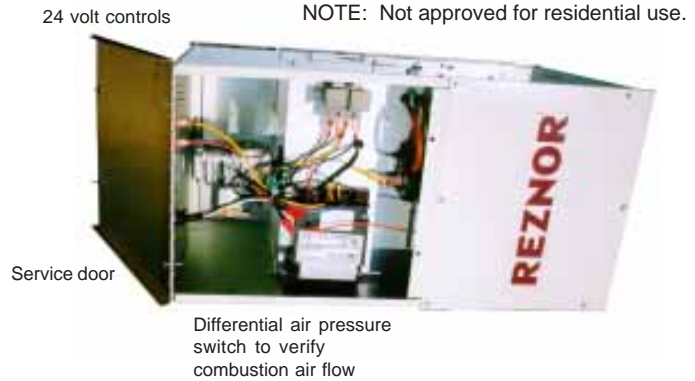
**REZNOR®****Model VR Gas-Fired Tubular Radiant, Low Intensity Heater for Indoor Commercial-Industrial Use****Model VR illustrating many standard features.****ANSI Z83.20****DESCRIPTION**

Model VR tubular radiant heaters are available in BTUH inputs of 50,000 to 200,000 and in tube lengths from 20 to 70 feet (see the Technical Data Table for BTUH/length combinations). All sizes are available for use with natural gas or optional propane gas. Model VR heaters provide full input rate heating capacity to 2,000 feet elevation. Tubular radiant heaters are engineered to provide quiet, reliable, energy-efficient, comfort level heating for both spot and space applications.

Model VR is designed with a burner/control box housing a power burner that fires into a 4" diameter tube, 20 to 70 feet in length. The burner is equipped with a blower for supplying combustion air and a multi-try direct ignition with 100% lockout. Controls include a single-stage gas valve and a pressure switch to verify combustion air flow.

The tubes are in 10-foot sections with each section having a polished reflector. The tube attached to the burner is the combustion chamber, all other sections are highly emissive heat exchanger tubes. The standard configuration is straight, but optional "L" shaped, "U" shaped and 5-foot straight heat exchanger tubes are available to change the configuration to adapt to various applications. A tubular system including an optional "U" tube provides the best balance of radiant emission over the length of any system. For maximum efficiency, the exhaust end of all systems is equipped with an aluminized steel turbulator strip.

Combustion air can either come from the heated space or be piped from the outside. Outside combustion air should be supplied (1) if the building atmosphere has negative pressure; (2) if the building atmosphere is dirty or dusty; (3) if the building atmosphere contains substances that will cause toxic gas when combined with flame or flue products; or (4) if the heater is being installed in a tightly closed room that does not provide required air for combustion.

Venting may be either vertical or horizontal. Dual venting of two units is permissible when using a Reznor Optional Dual Vent Kit.

Model VR tubular heater systems are shipped in modular packages requiring field assembly and installation. Standard features, such as wire form hangers for chain suspension, compression coupling tube connections, and terminal board thermostat connection, are designed to facilitate installation.

These heaters are approved for use in the United States and Canada by the Canadian Standards Association (CSA). Reznor provides a five-year limited warranty on the burner and a ten-year limited warranty on all tubes.

**STANDARD FEATURES**

- Natural gas operation
- Full input rate for elevations to 2,000 ft.
- 115/1 supply voltage
- Multi-try direct ignition with 100% lockout
- Single-stage combination gas valve (field adjustable for operation to 10,000 ft. elevation)
- Pre-purge and post-purge
- Differential air pressure switch to verify combustion air flow
- Diagnostic indicator light
- Sight glass for burner observation
- External terminal board connection for 24-volt thermostat
- Grounded, plug-in cord
- 16-gauge aluminized steel combustion chamber (10 ft. length)
- High emissivity radiant tubes, 16-gauge HRS (10 ft. lengths)
- Compression coupling tube connections
- Wire form hangers
- Polished aluminum reflectors (10 ft. lengths) that overlap for continuous reflector system
- Aluminized steel flue gas turbulators for maximum efficiency
- Horizontal or vertical venting
- Painted Cabinet
- Transformer for 24-volt controls

**OPTIONAL FEATURES - Factory Installed**

- Single stage propane gas valve (field adjustable for operation to 10,000 ft. elevation)
- 208/1 Supply Voltage (Models 50 - 175)
- 230/1 Supply Voltage (Models 50 - 175)

**OPTIONAL FEATURES - Field Installed**

- "U" Heat Exchanger Tube with Reflector
- "L" Heat Exchanger Tube(s) with Reflector
- 5-ft. Heat Exchanger Tube with Reflector
- Reflector End Covers
- Side Shield
- Hanger Kit
- Outdoor Combustion Air Inlet Kit
- Dual Vent Kit
- Multiple Heater Control for zoning up to 6 units
- Flexible Gas Connector
- High Altitude Field Conversion Kits (6,000 - 10,000 ft.)
- Unit-Mounted Thermostat Bracket
- Gas conversion kits (natural & propane)
- Vent Cap
- Manual shutoff valve & union
- Thermostat

## Model VR

### TECHNICAL DATA

Model No.		50-20	50-30	50-40	75-20	75-30	75-40	100-30	100-40	100-50	125-30	125-40	125-50	125-60	
Heating Capacity Input	BTUH	50,000			75,000			100,000			125,000				
	kW	14.7			22.0			29.3			36.6				
No. of 10-ft (3m) Tubes		2	3	4	2	3	4	3	4	5	3	4	5	6	
Gas Supply Pressure	Natural	"w.c."	4.5"-14"			4.5"-14"			4.5"-14"			4.5"-14"			
		mbar	11.2 - 34.9			11.2 - 34.9			11.2 - 34.9			11.2 - 34.9			
	Propane	"w.c."	11"-14"			11"-14"			11"-14"			11"-14"			
		mbar	27.4 - 34.9			27.4 - 34.9			27.4 - 34.9			27.4 - 34.9			
Gas Manifold Pressure	Natural	"w.c."	3.5"			3.5"			3.5"			3.5"			
		mbar	8.72			8.72			8.72			8.72			
	Propane	"w.c."	10"			10"			10"			10"			
		mbar	24.9			24.9			24.9			24.9			
Voltage/Phase		115/1			115/1			115/1			115/1				
Frequency (hertz)		60			60			60			60				
Control Amps (24V)		0.8			0.8			0.8			0.8				
Full Load Amps (115V)		1.1			1.1			1.1			0.8				
Net Weight	lbs	121	154	200	121	154	200	154	200	241	154	200	241	274	
	kg	55	70	91	55	70	91	70	91	109	70	91	109	124	
Ship Weight	lbs	153	186	255	153	186	255	186	255	293	186	255	293	326	
	kg	69	84	116	69	84	116	84	116	133	84	116	133	148	

Model No.		150-40	150-50	150-60	175-40	175-50	175-60	175-70	200-50	200-60	200-70	
Heating Capacity Input	BTUH	150,000			175,000			200,000				
	kW	44.0			51.3			58.6				
No. of 10-ft (3m) Tubes		4	5	6	4	5	6	7	5	6	7	
Gas Supply Pressure	Natural	"w.c."	4.5"-14"			6"-14"			6"-14"			
		mbar	11.2 - 34.9			14.9 - 34.9			14.9 - 34.9			
	Propane	"w.c."	11"-14"			11"-14"			11"-14"			
		mbar	27.4 - 34.9			27.4 - 34.9			27.4 - 34.9			
Gas Manifold Pressure	Natural	"w.c."	3.5"			5"			5"			
		mbar	8.72			12.5			125			
	Propane	"w.c."	10"			10"			10"			
		mbar	24.9			24.9			24.9			
Voltage/Phase		115/1			115/1			115/1				
Frequency (hertz)		60			60			60				
Control Amps (24V)		0.8			0.8			0.8				
Full Load Amps (115V)		0.8			1.2			1.2				
Net Weight	lbs	200	241	274	200	241	274	312	241	274	312	
	kg	91	109	124	91	109	124	142	109	124	142	
Ship Weight	lbs	255	293	326	255	293	326	390	293	326	390	
	kg	116	133	148	116	133	148	177	133	148	177	

## OPTIONS

### Reflector End Covers

End caps vertically "close" both the combustion chamber end and the exhaust end heat exchanger of the reflector system.

### Side Shield

An optional side shield may be added to Model VR heaters. With an optional side shield installed along one side of the length of a straight tubular system, the heater may be installed with much less clearance to combustibles.

The aluminum side shield is a modular design with two sections per 10-ft. tube. The modular sections hang from the tube reflector brackets. Reflector brackets, reflectors, and optional side shield are designed for easy installation.

## Dimensions

### Model VR

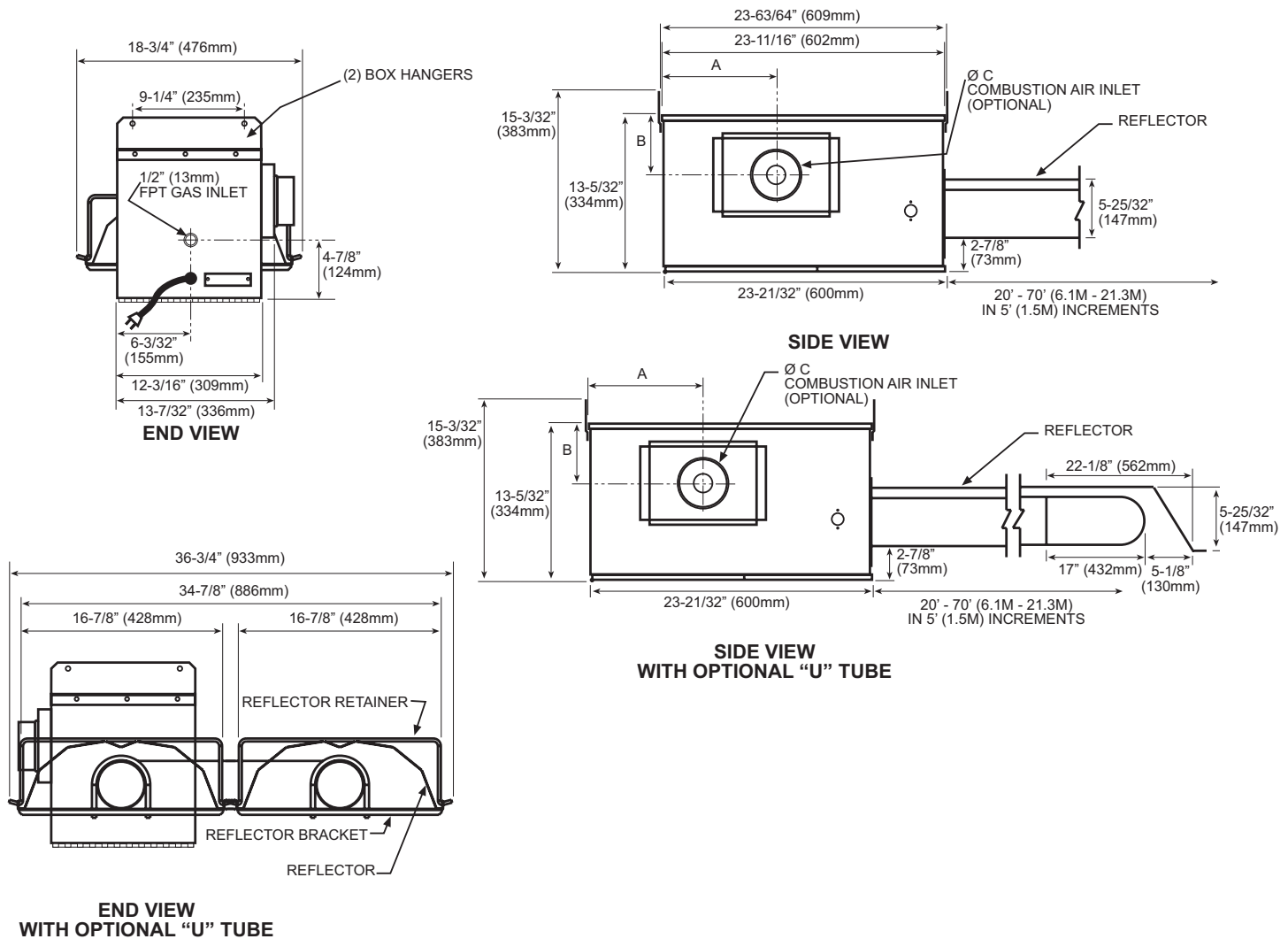

Size	A		B		C	
	in.	mm	in.	mm	in.	mm
50, 75, 100	9 17/32	242	5 1/32	128	4	102
125, 150	9 5/8	244	5 1/16	129	4	102
175, 200	9 5/8	244	5 1/16	129	5	127

### 5-Foot Heat Exchanger

Five-foot heat exchanger tubes are available to customize a tubular system to "fit" the area needing heat.

Overall minimum and maximum lengths by size do not change:

Order the shorter length system plus the needed quantity of 5-ft. heat exchanger tubes (Option UA1); or, see the "Ordering Methods" section of this catalog for information on how to order and stock the components to build a modular system. Whether ordered as an option or a part, the 5-ft. tube, its reflector, and hardware will arrive in a separately-marked carton.

**Note: A 10 ft. tube must always be placed at the exhaust end of the unit.**

Size	Alternate Tube Lengths							
	Feet	20	25	30	35	40	--	--
50	Meters	6.1	7.6	9.1	10.7	12.2	--	--
	Feet	20	25	30	35	40	--	--
75	Meters	6.1	7.6	9.1	10.7	12.2	--	--
	Feet	20	25	30	35	40	--	--
100	Meters	9.1	10.7	12.2	13.7	15.2	--	--
	Feet	30	35	40	45	50	--	--
125	Meters	9.1	10.7	12.2	13.7	15.2	16.8	18.3
	Feet	30	35	40	45	50	55	60
150	Meters	12.2	13.7	15.2	16.8	18.3	--	--
	Feet	40	45	50	55	60	--	--
175	Meters	12.2	13.7	15.2	16.8	18.3	19.8	21.3
	Feet	40	45	50	55	60	65	70
200	Meters	15.2	16.8	18.3	19.8	21.3	--	--
	Feet	50	55	60	65	70	--	--

# Venting Requirements

## Model VR

- Compliance with National and Local Codes
- 4” Vent Pipe (26-gauge single-wall galvanized metal)
- Terminal Vent Cap - use Reznor vent cap or equivalent
- Vent Length - see table below

### SINGLE WALL METAL VENT PIPE

Model No.		50					75					100					125						
Length	Feet	20	25	30	35	40	20	25	30	35	40	30	35	40	45	50	30	35	40	45	50	55	60
	Meters	6.1	7.6	9.1	10.7	12.2	6.1	7.6	9.1	10.7	12.2	9.1	10.7	12.2	13.7	15.2	9.1	10.7	12.2	13.7	15.2	16.8	18.3
Vent Diameter		in.	4					4					4					4					
		mm	102					102					102					102					
Vent Length	Minimum	Feet	5					5					5					5.0					
		Meters	1.5					1.5					1.5					1.5					
	Maximum	Feet	20					45	35	20	45	35	20	60									
		Meters	6.1					13.7	10.7	6.1	13.7	10.7	6.1	18.3									
Equivalent Length for	90° Elbow	Feet	3					6	5	3	6	5	3	12									
		Meters	0.9					1.8	1.5	0.9	1.8	1.5	0.9	3.7									
	45° Elbow	Feet	1.5					3.0	2.5	1.5	3.0	2.5	1.5	6									
		Meters	0.5					0.9	0.8	0.5	0.9	0.8	0.5	1.8									
	Dual Vent Adapter*	Feet	3					6	5	3	6	5	3	12									
		Meters	0.9					1.8	1.5	0.9	1.8	1.5	0.9	3.7									

Model No.		150					175						200					
Length	Feet	40	45	50	55	60	40	45	50	55	60	65	70	50	55	60	65	70
	Meters	12.2	13.7	15.2	16.8	18.3	12.2	13.7	15.2	16.8	18.3	19.8	21.3	15.2	16.8	18.3	19.8	21.3
Vent Diameter		in.	4					4						4				
		mm	102					102						102				
Vent Length	Minimum	Feet	5					5						5				
		Meters	1.5					1.5						1.5				
	Maximum	Feet	60					60						60				
		Meters	18.3					18.3						18.3				
Equivalent Length for	90° Elbow	Feet	12					12						12				
		Meters	3.7					3.7						3.7				
	45° Elbow	Feet	6.0					6.0						6.0				
		Meters	1.8					1.8						1.8				
	Dual Vent Adapter*	Feet	12					12						12				
		Meters	3.7					3.7						3.7				

- Vent Terminal Direction - Horizontal or Vertical
- Dual Venting - with Optional Dual Vent Kit only\*\*
- Unvented - Approved for Unvented Operation

#### Factors to Consider for Unvented Operation

- Check local codes
- Fresh Air Requirements - Natural gas, 4 CFM/1000 BTUH; Propane gas, 5 CFM/1000 BTUH
- Unvented operation may cause excessive condensation inside the building
- Do not operate unvented in dusty or dirty atmosphere
- Do not operate unvented in a building where contaminants in the air will produce a toxic gas when burned or exposed to high temperature
- Do not operate unvented with outside combustion air
- Reznor **STRONGLY** recommends venting to the outdoors in any application that do not have independent exhaust systems and/or high volumes of dilution with outside air. See installation manuals for unvented operation requirements.

\*\* Technical data for these options is found elsewhere in this catalog.

# Venting Requirements and Outside Air Combustion

## Model VR

### Dual Venting

This design (U.S. Patent No. 5,421,774) allows dual venting of two Model VR heaters. The concentric design of the vent allows each of the two heaters to be safely operated totally independent of the other. Heaters vented through the optional dual vent do not have to match in capacity, length, or configuration and may be controlled by the same or different thermostats.

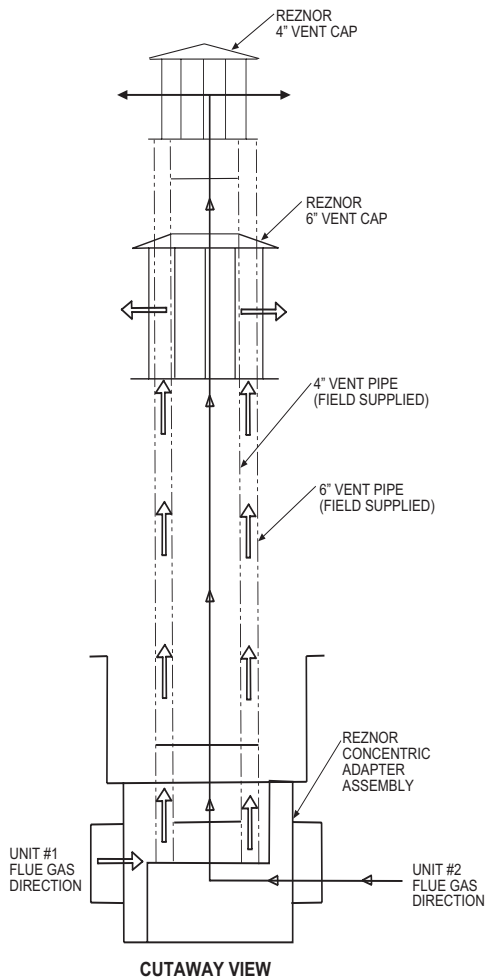

### Outside Combustion Air

Model VR heaters may be operated with combustion air from the heated space or with combustion air piped from outside. If outside combustion air is selected, a Reznor outside combustion air kit must be installed. Outside combustion air may be supplied in any vented application but should always be supplied (1) if the building atmosphere has negative pressure; (2) if the building atmosphere is dirty or dusty; (3) if the building atmosphere contains substances that will cause toxic gas when combined with flame or flue products; (4) if the heater is installed in a tightly closed room that does not provide required air for combustion.

The outside combustion air kit for Model VR heaters includes a section of 4" (5" on sizes 175 & 200) flexible pipe expandable to three feet, a special designed inlet air cap, an air inlet cover with collar, relay with wiring, and two clamps. The maximum length of the field-supplied combustion air pipe depends on the size and length of heater and the type of pipe.

### Combustion Air Inlet Length Table

**NOTE:** Do not install an outside combustion air inlet on an unvented heater.

MAXIMUM LENGTH OF OUTSIDE COMBUSTION AIR INLET PIPE							
TYPE OF INLET PIPE	SIZE MBH	MAXIMUM LENGTH		EQUIVALENT LENGTH FOR			
		Feet	Meters	90° Elbow		45° Elbow	
				Feet	Meters	Feet	Meters
Smooth Wall <sup>A</sup>	50	80	24.4	10	3.0	5	1.5
	75						
	100	60	18.3	10	3.0	5	1.5
	125						
	150						
Corrugated or Flexible	175	40	12.2	N/A	N/A	N/A	N/A
	200						
	50	30	9.1	N/A	N/A	N/A	N/A
	75						
	100						
		125	30	9.1	N/A	N/A	N/A
150							
175							
	200						

<sup>A</sup> Assumes the use of three feet of flexible pipe at the combustion air inlet on the burner/control box



# Heater Configurations

## Model VR

An advantage of tubular infrared heating is its versatility in configuration layout. A booklet illustrating all permissible configurations, is available for designing applications. See sample diagrams below. For even harder-to-fit areas, 5-ft. Heat Exchanger Tubes (Option UA1) are available. All configurations require a modular turbulator strip (  ).

### Straight-Standard Configuration for All Sizes and Lengths

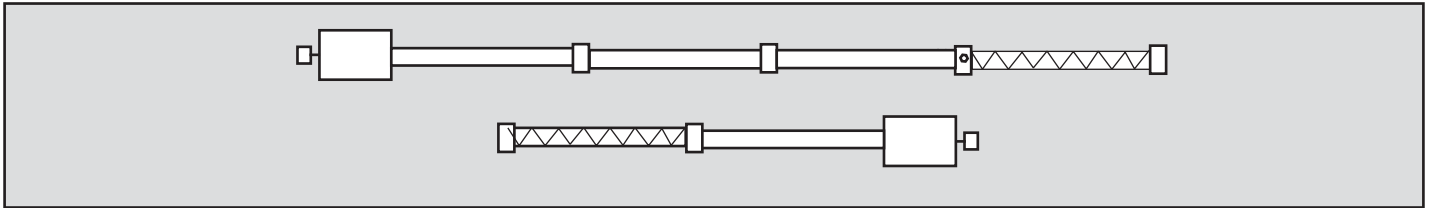

### "U"-Model VR with a "U" Heat Exchanger Tube, Option UB3

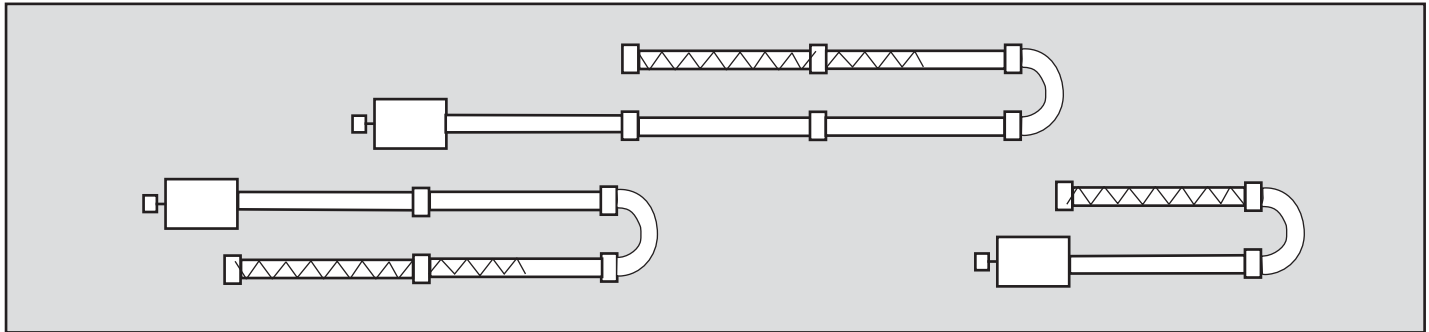

### "L"-Model VR with one or two "L" Heat Exchanger Tube(s), Option UC2

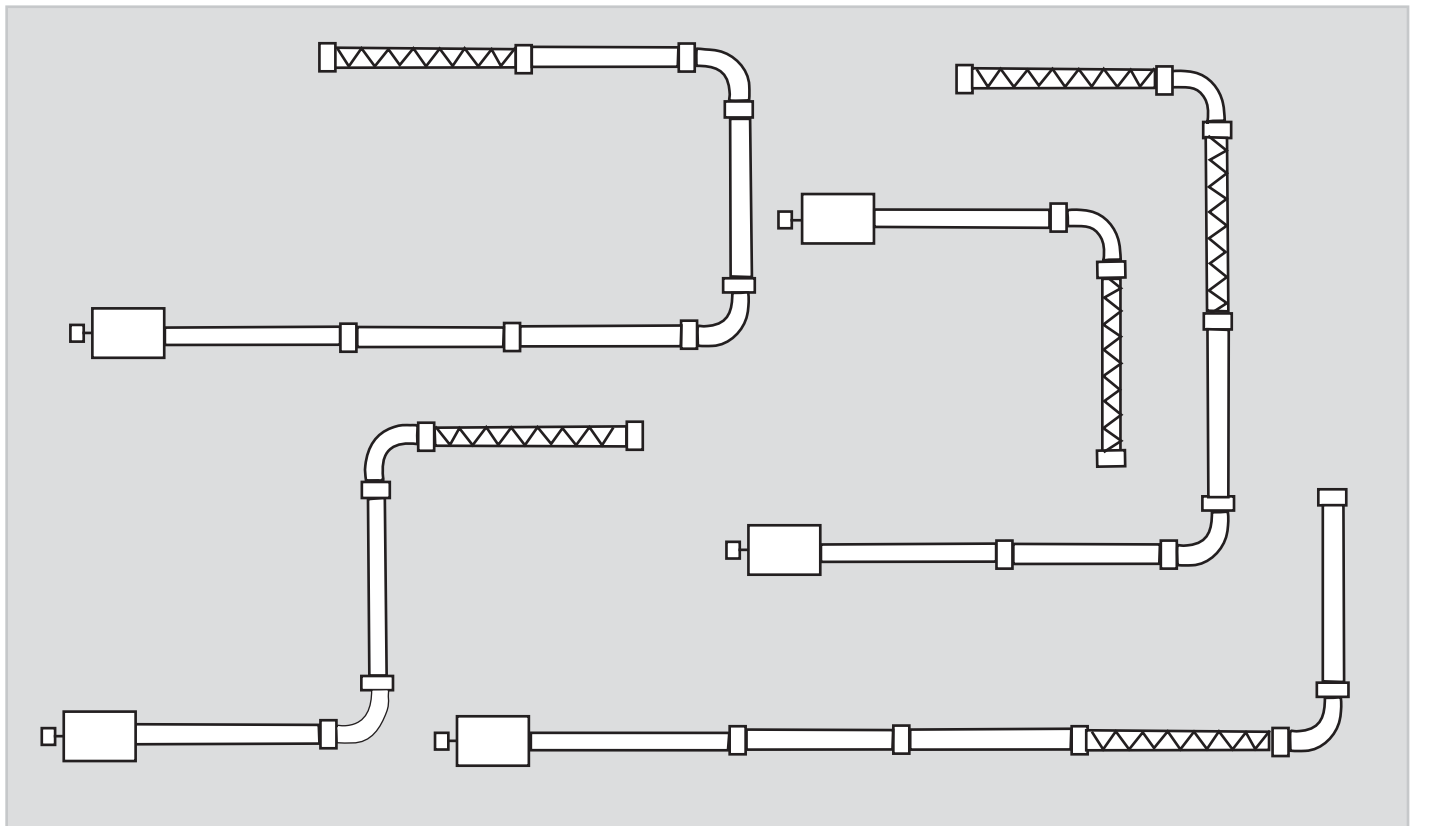

**IMPORTANT:** Do not install an Model VR tubular radiant heater in any configuration other than those intended. For more information, see your Reznor Representative.

Required clearances depend on the size of the heater (BTUH input), the position of the reflector, and the addition of an optional side shield. The side shield is a field-installed, modular shield (2 pieces per 10 ft. tube length). The shield hangs vertically on the “rear” side only, along the entire length of a straight tubular system. Refer to Clearance Orientation Illustrations to define “Top”, “Below”, “Front”, and “Rear” clearances. The clearances listed are installation requirements. In addition, ANSI Z-223.1, Section 6.18, requires that signs be posted specifying the maximum permissible stacking heights to assure that the required clearances from the heater to combustibles are maintained.

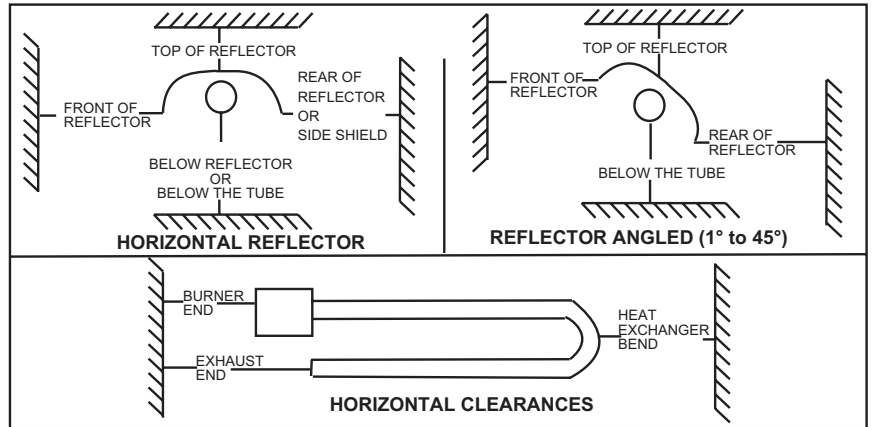

**Location Recommendations for Efficient Application**

When selecting the installation location, major factors to consider are (1) Personal and Property Safety, (2) Personal Comfort, and (3) Heating Efficiency. Because of the unique features of radiant heat transfer, selecting the most efficient location for infrared equipment depends on the “floor” coverage of the emitted heat rays. Floor coverage distance can be figured as approximately two times the mounting height of the unit. However, comfort level heating depends on the infrared intensity and on the balance of the radiant emission over the length of the system. Infrared intensity decreases with higher mounting heights and greater floor coverage. **IMPORTANT: Another factor when locating the heater in relation to people is that the heat emitted**

		CLEARANCES TO COMBUSTIBLES								
SIZE			50	75	100	125	150	175	200	
ALL HEATERS	BELOW	in.	66	66	66	78	78	84	84	
		mm	1,676	1,676	1,676	1,981	1,981	2,134	2,134	
	TOP*	in.	12	12	12	12	12	12	12	
		mm	305	305	305	305	305	305	305	
	HORIZONTAL CLEARANCES	BURNER END	in.	24	24	24	30	30	30	30
			mm	610	610	610	762	762	762	762
			HEAT EXCHANGER	in.	36	36	36	48	48	48
		EXHAUST END	mm	914	914	914	1,219	1,219	1,219	1,219
			in.	24	24	24	24	24	24	24
			mm	610	610	610	610	610	610	610
VENT		in.	6	6	6	6	6	6	6	
		mm	152	152	152	152	152	152	152	
WITH REFLECTOR POSITIONED	0 - 30°	FRONT	in.	30	30	30	42	42	54	54
			mm	762	762	762	1,067	1,067	1,372	1,372
		REAR	in.	30	30	30	42	42	54	54
			mm	762	762	762	1,067	1,067	1,372	1,372
	31 - 45°	FRONT	in.	48	48	48	66	66	78	78
			mm	1,219	1,219	1,219	1,676	1,676	1,981	1,981
		REAR	in.	18	18	18	32	32	36	36
			mm	457	457	457	813	813	914	914
	0 - 30° WITH SIDE SHIELD	FRONT	in.	36	36	36	42	42	54	54
			mm	914	914	914	1,067	1,067	1,372	1,372
		REAR	in.	12	12	12	12	12	12	12
			mm	305	305	305	305	305	305	305

\* If Model VR is unvented, top clearance is 18 inches (457mm).

from the burner/combustion chamber end of a tubular infrared heater is more intense than the heat emitted from the exhaust end. Configurations including an optional “U” tube provide the best balance of radiant emission over the length of the system.

**For space heating** infrared applications, the location of the unit must be evaluated as part of the heater size selection. In order to select the proper heater size, determine the total BTUs required, the floor coverage required, and the mounting height. From this information, design a heater size and location plan that will provide the most complete floor coverage without excessive overlapping. In most cases, perimeter heaters should be located parallel to the wall. The distance from the wall to the unit is determined by whether the reflectors will be angled, horizontal, or with side shields.

**For spot heating** applications, the tubular system should be located to direct the rays toward the area requiring heat. Depending on the installation, this can be done from directly overhead or reflector angled from the side. U-tube configurations are often best suited to overhead spot heating applications. Use the mounting height, the size of the heater, the heater configuration, and the application conditions to determine the most efficient location for the heater.

**WARNING: GAS-FIRED APPLIANCES ARE NOT DESIGNED FOR USE IN HAZARDOUS ATMOSPHERES CONTAINING FLAMMABLE VAPORS OR COMBUSTIBLE DUST, OR ATMOSPHERES CONTAINING CHLORINATED OR**

**HALOGENATED HYDROCARBONS. INSTALLATIONS IN PUBLIC GARAGES OR AIRPLANE HANGARS ARE PERMITTED WHEN IN ACCORDANCE WITH ANSI Z83.6B AND NFPA-408 AND 88 CODES OR CANI-B149 CODES AND ENFORCING AUTHORITIES.**

Installations of Model VR heaters in the United States must be in accordance with the National Fuel Gas Code ANSI Z-223.1 (latest edition) and all local codes. In Canada, installations must be in accordance with the latest edition of CAN/CSA B149.1 and B149.2 and any local authorities having jurisdiction.

To allow for thermal expansion, Model VR heaters must be suspended with chain and must have flexible gas and electric connections.

Chain must have a minimum load-carrying capacity of 200 lbs. Depending on the type of building construction, the installer may either attach the chain support directly to the building or attach and extend a support to the location needed (all chain supporting tube sections must be plumb). SUPERSTRUT® brackets or a comparable metal strut material is well suited as a support structure that requires numerous suspension points. Model VR heaters must be level. The use of turnbuckles is not required but is recommended to assist in leveling the heater. If used, turnbuckles must be of steel or malleable iron. Optional chain kits and turnbuckle kits are available from Reznor.

Each burner/control box is equipped with a grounded, plug-in electrical cord. Gas connection must be with either an expansion coil or an approved stainless steel flexible connector. Optional flexible connectors are available from Reznor. Flexible connectors do affect gas pressure. Pressure drops for flexible connectors available from Reznor are listed below. (Required gas pressures found in Technical Data Tables.)

RECOMMENDED MINIMUM MOUNTING HEIGHTS								
Reflector Position		Model (000 BTUH Input)						
		50	75	100	125	150	175	200
Horizontal	Feet	11	12	13	15	16	17	18
	Meters	3.4	3.7	4.0	4.6	4.9	5.2	5.5
30° Angle	Feet	9	10	11	13	14	15	16
	Meters	2.7	3.0	3.4	4.0	4.3	4.6	4.9
45° Angle	Feet	8	9	10	11	13	14	15
	Meters	2.4	2.7	3.0	3.4	4.0	4.3	4.6

GAS PRESSURE DROP ("W.C.) THROUGH 24" STAINLESS STEEL FLEXIBLE CONNECTORS AVAILABLE FROM REZNOR								
Size		50	75	100	125	150	175	200
13 mm (1/2") I.D.	in. w.c.	0.25	0.25	0.25	0.50	0.75	0.80	0.90
	mbar	0.62	0.62	0.62	1.25	1.87	1.99	2.24
19 mm (3/4") I.D.	in. w.c.	0.05	0.05	0.10	0.15	0.20	0.40	0.50
	mbar	0.12	0.12	0.25	0.37	0.50	1.00	1.25

## Model VR heaters are designed with these installation advantages:

### -Modular turbulator strips with interlocking connections

All tube packages include a field-installed turbulator strip. The turbulator strip is slid into the tube in small, easy-to-handle sections. By interlocking the sections as they are installed, the required number of sections can be slid into the tube creating the full-sized turbulator strip.

### -Reflector retainers/hangers

Reflectors are required to direct radiant heat. Reflectors, reflector brackets, and hardware "kits" are included in the tube packages. The reflector retainers extend over the installed reflectors securing the reflector to the tube and act as a hanger connection.

### -Terminal strip for thermostat connection

The burner/control box is equipped with a terminal strip for connection of a remote thermostat, or the thermostat may be attached to the heater by using an optional thermostat bracket. Up to six heaters may be controlled by one thermostat or time clock by installing a multiple heater control option.

### - Tube connections

All tubes are joined by a compression coupling. All required parts for each tube connection are shipped in the tube carton.

#### Step 1

Align tubes and insert into compression coupler.



#### Step 2

Tighten bolts on compression coupler.



#### Step 3

Install self-drilling screws in holes provided in coupler opposite the bolts.

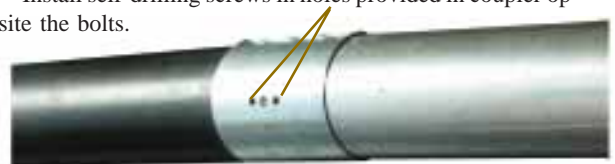

## Model VR

### Burner Box Packaging Scheme

- **Ordering for a Specific Job** - Burner boxes are factory-built and shipped in the sizes indicated in the table below. Tube lengths ordered should match the capacity of the heater ordered.
- **Ordering Burner Boxes for Stock** - Burner boxes are designed for convenience of the stocking distributor.

Tubes for any standard length of heater are packaged in a maximum of only four carton types. The Packaging Scheme allows the stocking distributors to inventory the tube packages in whatever lengths meets their most frequent requirements.

By matching the burner/control boxes and the tube packaging scheme, a variety of heater sizes and lengths are “in stock” with minimum inventory.

Desired MBH Input	Model Number	Heater Tube Length Range
50	VR50	20 - 40 ft.
75	VR75/100	20 - 40 ft.
100	VR75/100 <sup>A</sup>	30 - 50 ft.
125	VR125/150	30 - 60 ft.
150	VR125/150 <sup>B</sup>	40 - 60 ft.
175	VR175/200	40 - 70 ft.
200	VR175/200 <sup>C</sup>	50 - 70 ft.

<sup>A</sup> VR75/100 - is factory-built as 75 MBH and includes a conversion kit to field-convert to 100 MBH.

<sup>B</sup> VR125/150 - is factory-built as 125 MBH and includes a conversion kit to field-convert to 150 MBH.

<sup>C</sup> VR175/200 - is factory-built as 175 MBH and includes a conversion kit to field-convert to 200 MBH.

### Tube Packaging Scheme

All cartons include the hardware required for assembly. Each tube package includes the equipment necessary to assemble that section including reflectors, reflector brackets, compression couplings, and turbulator strips.

**Packaging of Burner/Control Boxes** - Burner/control boxes are shipped in individual cartons. Each carton is identified by the Order No. and the Model and Serial No. of the heater.

**Packaging Scheme for Tubes** - A maximum of only three-packages is required to “build” any standard length of straight tubular system. All packages are identified by No. and contents. Cartons are engineered and packaged to allow for normal freight handling.

#### Packaging Scheme by Size for Straight Tubes

Contents of Tube Packages				
Part Number	205204	205205	205206	205151
10 ft. (3M) Combustion Chamber Tube	(1)	(1)	-	-
10 ft. (3M) Heat Exchanger Tube	(1)	(2)	(2)	(3)
Turbulators	(4)	(3)	(1)	(2)

Optional tubes are shipped separately in individually labeled cartons.

Shape	Option Number
5 ft. Straight	UA1
"U" Bend	UB3
"L" Bend	UC2

Reznor’s packaging scheme keeps the number and variety of packages to a minimum. By limiting the number of different cartons, the packaging scheme is designed to be beneficial for both maintaining inventory and ordering for a specific job.

All Model VR Heaters require a burner/control box, and a combustion chamber tube. The “length” of the system is determined by the number of straight heat exchanger tubes that are positioned after the combustion chamber tube. Refer to the installation manual to determine correct number of turbulator strips to be installed.

TOTAL SYSTEM LENGTH		REQUIRED COMPONENTS		REQUIRES THE FOLLOWING PART NUMBERS	
Feet	Meters	COMBUSTION CHAMBER	HEAT EXCHANGERS	1 EACH	2 EACH
20	6.1	1	1	205204	-
30	9.1	1	2	205205	-
40	12.2	1	3	205204 & 205206	-
50	15.2	1	4	205204 & 205151	-
60	18.3	1	5	205205 & 205151	-
70	21.3	1	6	205205	205056

Provide gas-fired tubular radiant heaters manufactured as Reznor brand units. The heaters shall be the Reznor Model VR Series, radiant tubular heaters with a power burner housed in a burner/control box firing into a 4" diameter combustion chamber tube. The burner/control box and tubular system shall be designed for horizontal suspension from field-supplied hanging chains.

Size 50,000 - 175,000 BTUH units shall be equipped for use with natural (propane) gas and 115/1 (208/1) (230/1) volt supply voltage and will operate a full input rate at elevations to 2,000 ft. Size 200,000 BTUH units shall be equipped for use with natural gas (propane) and 115/1 and will operate at full input rate at elevations to 2000 ft.

The burner control system shall have a 24-volt transformer; a multi-try direct spark ignition with 100% lockout; single-stage combination gas valve; LED diagnostic light; sight glass for observing flame; a power burner with pre-purge and post purge; a differential air pressure switch to measure combustion air; and a terminal board for connection of remote (unit mounted) thermostat. Electrical supply connection is with a grounded, plug-in cord. Gas connection to the valve must be with field-supplied expansion coil or approved flexible connector.

The tubular system shall include a 16-gauge aluminized steel combustion chamber, high emissivity radiant 10' (5') straight ("U") ("L") heat exchanger tubes, turbulator strips, wire form suspension hangers, compression coupling tube connections, and polished aluminum overlapping reflectors with reflector retainers. Heater may be individually (or dual) vented horizontally or vertically and may operate on either inside (or outside) combustion air. Reflectors may be positioned from horizontal to 45° angle. Horizontal reflectors may include optional side shield, and optional end covers. All connection hardware kits shall be packaged in individual bags and include illustrated instructions.

These units must be approved for use in The United States and Canada by the Canadian Standards Association (CSA). The manufacturer shall provide a 5-year limited warranty on the burner and all electrical and mechanical operating components and a 10-year limited warranty on the tubes.

(Capacities, lengths, illustration, and additional field-installed options as described in this catalog.)

### **Limited Warranty**

#### **Model VR Tubular Radiant Heaters**

Reznor warrants to the original owner-user that this Reznor product will be free from defects in material or workmanship. This warranty is limited to twelve (12) months from the date of original installation, whether or not actual use begins on that date, or eighteen (18) months from date of shipment by Reznor, whichever occurs first.

#### **Extended Limited Warranty**

Extended 9-year, non-prorated, limited warranty on all tubes.

Extended 4-year, non-prorated, limited warranty on the burner and all electrical and mechanical operating components.

#### **Limitations and Exclusions**

Thomas & Betts Corporation's obligations under this warranty and the sole remedy for its breach are limited to repair, at its manufacturing facility, of any part or parts of its Reznor products which prove to be defective; or, in its sole discretion, replacement of such products. All returns of defective parts or products must include the product model number and serial number, and must be made through an authorized Reznor distributor or arranged through Reznor Customer Service. Authorized returns must be shipped prepaid. Repaired or replacement parts will be shipped by Thomas & Betts F.O.B. shipping point.

1. The warranty provided herein does not cover charges for labor or other costs incurred in the troubleshooting, repair, removal, installation, service or handling of parts or complete products.
2. All claims under the warranty provided herein must be made within ninety (90) days from the date of discovery of the defect. Failure to notify Thomas & Betts of a warranted defect within ninety (90) days of its discovery voids Thomas & Betts's obligations hereunder.
3. The warranty provided herein shall be void and of no effect in the event that (a) the product has been operated outside its designed output capacity (heating, cooling, airflow); (b) the product has been subjected to misuse, neglect, accident, improper or inadequate maintenance, corrosive environments, environments containing airborne contaminants (silicone, aluminum oxide, etc.), or excessive thermal shock; (c) unauthorized modifications are made to the product; (d) the product is not installed or operated in compliance with the manufacturer's printed instructions; (e) the product is not installed and operated in compliance with applicable building, mechanical, plumbing and electrical codes; or (f) the serial number of the product has been altered, defaced or removed.
4. The warranty provided herein is for repair or replacement only. Thomas & Betts Corporation shall not be liable for any loss, cost, damage, or expense of any kind arising out of a breach of the warranty. Further, Thomas & Betts Corporation shall not be liable for any incidental, consequential, exemplary, special, or punitive damages, nor for any loss of revenue, profit or use, arising out of a breach of this warranty or in connection with the sale, maintenance, use, operation or repair of any Reznor product. In no event will Thomas & Betts be liable for any amount greater than the purchase price of a defective product. The disclaimers of liability included in this paragraph 4 shall remain in effect and shall continue to be enforceable in the event that any remedy herein shall fail of its essential purpose.
5. THIS WARRANTY IS THE SOLE AND EXCLUSIVE WARRANTY FOR REZNOR PRODUCTS, AND IS IN LIEU OF ALL OTHER EXPRESS AND IMPLIED WARRANTIES. THOMAS & BETTS CORPORATION SPECIFICALLY DISCLAIMS ALL OTHER EXPRESS AND IMPLIED WARRANTIES, INCLUDING, BUT NOT LIMITED TO, ALL IMPLIED WARRANTIES OF MERCHANTABILITY AND FITNESS FOR A PARTICULAR PURPOSE. No person or entity is authorized to bind Thomas & Betts Corporation to any other warranty, obligation or liability for any Reznor product. Installation, operation or use of the Reznor product for which this warranty is issued shall constitute acceptance of the terms hereof.

**RIH, RIHV Gas Fired High Intensity Infrared Heaters for Indoor Commercial-Industrial Use**



RIHN30



RIHVN200



ANSI Z83.19



CAN 2.35

NOTE: Not approved for outdoor use.

**DESCRIPTION**

Reznor High Intensity Infrared Models RIH, RIHV are designed to provide personal comfort heating with reduced energy cost. Units are available in sizes from 30,000 through 200,000 BTUH gas input for use with natural gas and sizes from 50,000 through 120,000 BTUH gas input for use with propane.

Infrared heaters can best be compared to the sun in how they heat. On a bright sunny day, you can feel the infrared rays of the sun heating your skin surface. The same infrared rays are also heating the concrete sidewalks and buildings. Infrared heating equipment works the same way - it warms people, heats floors, walls, machinery and other surfaces, without heating the air between. The “infrared heated” objects in turn warm the surrounding air. Eliminated are the costly ceiling heat losses and discomforts of cold air stratification that are so familiar with conventional forced air heating systems. Infrared heat assures floor level comfort with fuel savings up to 50%. Electrical energy is also saved because there is no need for a fan or blower.

In addition to the gas and electric energy savings, infrared heaters have other economical installation and operational features. Model RIH, RIHV heaters can be suspended by chains from a joist or mounted to a wall, making them well suited for space or spot heating. Direct venting is not required. Operational service and maintenance requirements are minimal due to the absence of moving parts.

Some sizes can be ordered with optional 2-stage heating. The first stage will fire at 1/2 or 2/3 of total capacity. If more heat is required second stage will fire for full capacity. A 2-stage thermostat **must** be used with 2-stage heaters. Two-stage operation provides fewer on/off cycles for improved comfort and longer life.

Model RIH, RIHV high intensity infrared units are design certified for use in The United States and Canada by the Canadian Standards Association (CSA).

**STANDARD FEATURES**

- 115 volt operation for single-stage models, 24 volt operation for 2-stage models
- Direct spark ignition, 100% safety shut-off
- Solenoid gas valve, 1/2” NPT inlet
- Ceramic combustion surface temperature up to 1850°F, capable of reaching full intensity temperature in less than 30 seconds
- Seamless aluminized steel plenum chamber with stainless steel ceramic tile retainer clips
- Venturi mixer of spun metal construction for precision metering of air/gas mixture
- Highly polished aluminum reflector
- Balanced suspension holes, 3/8” diameter

**OPTIONAL FEATURES**

- Limited lifetime warranty available on burner
- Parabolic reflector
- Wire grid for increased radiant efficiency
- Protective screens for standard reflector or parabolic reflector
- AlumiLens, includes aluminum grid, parabolic reflector and heat shield
- Heat deflector shield (to reduce required clearance above the heater) only available on 60 and 100 sizes
- 120/24V Thermostat (50° - 90°F)
- 2-Stage heating on sizes 90, 100, 120, 150
- 2-Stage 24V thermostat for use with 2-stage heaters only.
- Stainless steel flexible connector (24”) with manual valve
- Chain (50 ft.) with 14 “S” hooks
- Chain mounting kit (pre-assembled for one heater) for mounting heater at a 30° angle

**VENTILATION REQUIREMENTS**

- Natural Gas** - 4 CFM of positive air displacement per 1,000 BTUH
- Propane Gas** - 5 CFM of positive air displacement per 1,000 BTUH

## TECHNICAL DATA

MODELS		NATURAL GAS						PROPANE GAS			
		RIHN 30 <sup>A</sup>	RIHN 60 <sup>B</sup>	RIHVN 100 <sup>C</sup>	RIHVN 150 <sup>C</sup>	RIHVN 160	RIHVN200 <sup>C</sup>	RIHL 50	RIHVL 90 <sup>C</sup>	RIHVL 120 <sup>C</sup>	
HEATING INPUT	MBH	30	60	100	150	160	200	50	90	120	
	kW	8.8	17.6	29.3	44.0	46.9	58.6	14.7	26.4	35.2	
INLET GAS PRESSURE	MINIMUM	" w.c.	7	7	7	7	7	7	11	11	12
		mbar	17	17	17	17	17	17	27	27	30
	MAXIMUM	" w.c.	14	14	14	14	14	14	14	14	15
		mbar	35	35	35	35	35	35	35	35	37
ALLOWABLE MOUNTING ANGLE (in degrees)		0 - 30 deg.	0 - 30 deg.	5 - 30 deg.	0 - 30 deg.	5 - 30 deg.	5 - 30 deg.	10 - 30 deg.	10 - 30 deg.	30 deg. ONLY	
GAS CONNECTION	in.	1/2	1/2	1/2	1/2	1/2	1/2	1/2	1/2	1/2	
	mm	13	13	13	13	13	13	13	13	13	
SHIPPING WEIGHT	Lbs.	30	30	36	49	62	62	30	36	49	
	Kg	14	14	16	22	28	28	14	16	22	

<sup>A</sup> MODEL RIHN30 is not available in Canada.

<sup>B</sup> MODEL RIHN60 in Canada requires addition of a wire grid, Option DN2.

<sup>C</sup> These sizes are available in two-stage operation see explanation below.

## DIMENSIONAL DATA

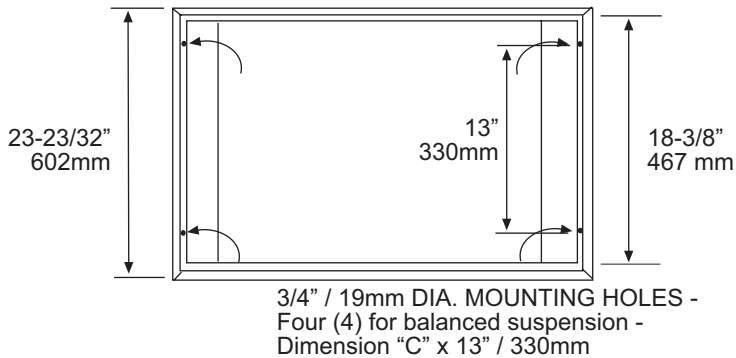

TOP VIEW

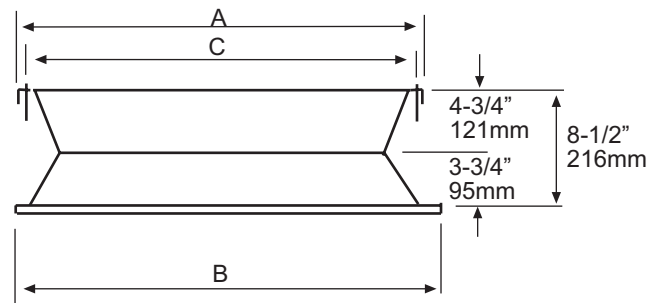

FRONT VIEW

DIMENSIONS ACCURATE TO WITHIN 3mm or 1/8 in.

SIZE	A		B		C	
	in.	mm	in.	mm	in.	mm
30, 50, 60	15 5/16	389	16 5/8	422	14 5/8	371
90, 100	23 15/16	608	25 1/4	641	23 1/4	591
120, 150, 160	32 9/16	827	33 7/8	860	31 7/8	810
200	41 13/16	1,062	42 1/2	1,080	40 1/2	1,029

## 2-STAGE OPERATION

Model Size	Fuel	MBH	
		First Stage	Full Capacity
RIHVL90	Propane	45	90
RIHVN100	Natural Gas	50	100
RIHVL120	Propane	80	120
RIHVN150	Natural Gas	100	150
RIHVN200	Natural Gas	100	200



Heater shown with AlumiLens aluminum grid

**Clearance from Combustibles (See diagram below)**

		Natural Gas Models						Propane Gas Models		
		RIHN 30 <sup>A</sup>	RIHN 60 <sup>B</sup>	RIHVN 100 <sup>C</sup>	RIHVN 150	RIHVN 160 <sup>C</sup>	RIHVN 200	RIHL 50 <sup>C</sup>	RIHVL 90 <sup>C</sup>	RIHVL 120 <sup>C</sup>
<b>Side Clearance</b>	<b>inches</b>	30	30	36	46	48	48	30	36	46
	<b>mm</b>	762	762	914	1,168	1,219	1,219	762	914	1,168
<b>Back Clearance</b>	<b>inches</b>	30	30	30	33	33	33	30	30	33
	<b>mm</b>	762	762	762	838	838	838	762	762	838

**Top Clearance**

Mounted 0-29° (no heat deflector)	<b>inches</b>	60	60	62	64	68	68	60	62	N/A
	<b>mm</b>	1,524	1,524	1,575	1,626	1,727	1,727	1,524	1,575	
Mounted 30° only (no heat deflector)	<b>inches</b>	48	48	50	58	68	68	48	50	58
	<b>mm</b>	1,219	1,219	1,270	1,473	1,727	1,727	1,219	1,270	1,473
Mounted 0-30° with Heat Deflector, Option DO2 or DN4	<b>inches</b>	28	34	38	N/A	N/A	N/A	28	38	N/A
	<b>mm</b>	711	864	965				711	965	

**Below Clearance**

Standard Reflector	<b>inches</b>	80	80	105	125	140	140	80	105	125
	<b>mm</b>	2,032	2,032	2,667	3,175	3,556	3,556	2,032	2,667	3,175
With Parabolic Reflector, Option DM2 or DN4	<b>inches</b>	110	110	135	165	180	180	110	135	165
	<b>mm</b>	2,794	2,794	3,429	4,191	4,572	4,572	2,794	3,429	4,191

<sup>A</sup> Model RIHN 30 is not available in Canada.

<sup>B</sup> Model RIHN60 in Canada requires addition of wire grid, Option DN2.

<sup>C</sup> See allowable mounting angles on previous page.

**INSTRUCTIONS:**

1. Hang full length chains at desired height and attach to back of heater (C) with S-hooks.
2. Attach one end of the 1' length chains with S-hooks to front of heater (D).
3. Place other end of chains with S-hooks in loop (B) on the full length chain.
4. Check degree of angle mounting. Adjust degree of mounting angle by moving "S" hooks at point B.
5. Check to be sure unit is level. Crimp all "S" hooks closed.

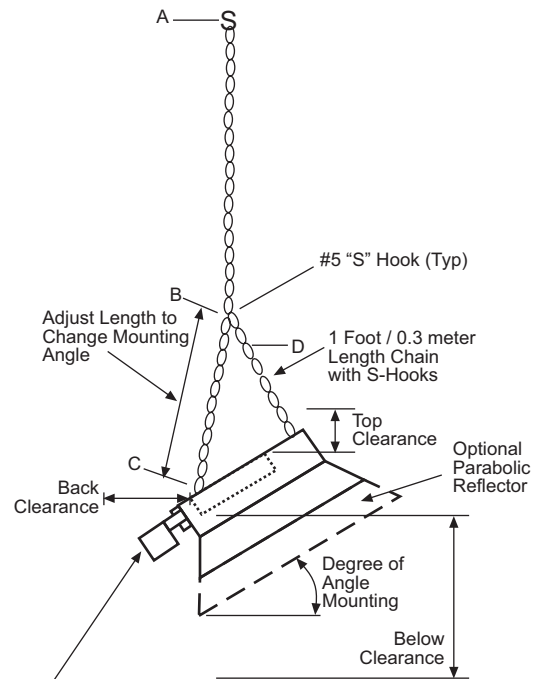

**IMPORTANT:** Gas manifold must be located on low side of heater.

**COVERAGE -** For complete space heating coverage, maximum distance between heaters is two times the mounting height.

Recommended Distance from a Wall for Units Mounted HORIZONTALLY		
Model	With Standard Reflector	With Parabolic Reflector, Option DM2 or DN4
RIHN 30	8 ft (2.4M)	5 ft (1.5M)
RIHN 60	12 ft (3.7M)	9 ft (2.7M)
RIHVN 150	20 ft (6.1M)	15 ft (4.6M)
RIHVN 200	24 ft (7.3M)	20 ft (6.1M)



## Location/Installation

### Models RIH/RIHV - High Intensity Infrared Heaters

**MOUNTING ANGLE MUST BE WITHIN THE RANGE ALLOWED**

MODEL	ALLOWABLE MOUNTING ANGLE RANGE	IMPORTANT
RIHN 30	HORIZONTAL TO 30 deg.	When angle mounted, all RIHV Models must be installed with the gas manifold on the lower end. When angle mounted, RIH Models must be installed with the gas valve on the high side. Do not angle heaters more than 30°.
RIHL 50	10 - 30 deg.	
RIHN 60	HORIZONTAL TO 30 deg.	
RIHVL 90	10 - 30 deg.	
RIHVN 100	5 - 30 deg	
RIHVL 120	30 deg. ONLY	
RIHVN 150	HORIZONTAL TO 30 deg.	
RIHVN 160	5 - 30 deg	
RIHVN 200	HORIZONTAL TO 30 deg.	

**MINIMUM MOUNTING HEIGHT**

Model	With Standard Reflector				With Parabolic Reflector, Option DM2 or DN4			
	HORIZONTAL		30°		HORIZONTAL		30°	
	ft	M	ft	M	ft	M	ft	M
RIHN 30	11.0 - 13.0	3.4 - 4	10.0 - 12.0	3 - 3.7	N/A		N/A	
RIHL 50*	13.5 - 15.5	4.1 - 4.7	12.5 - 14.5	3.8 - 4.4	15.5 - 18.5	4.7 - 5.6	14.0 - 17.0	4.3 - 5.2
RIHN 60	14.5 - 16.5	4.4 - 5	13.0 - 15.0	4 - 4.6	16.0 - 20.0	4.9 - 6.1	15.0 - 18.0	4.6 - 5.5
RIHVL 90*	16.0 - 18.5	4.9 - 5.6	14.5 - 17.0	4.4 - 5.2	19.5 - 22.5	5.9 - 6.9	17.5 - 20.5	5.2 - 6.2
RIHVN 100*	17.0 - 19.5	5.2 - 5.9	15.0 - 17.5	4.6 - 5.3	20.5 - 23.5	6.2 - 7.2	18.5 - 21.5	5.6 - 6.6
RIHVL 120*	N/A		15.5 - 18.5	4.7 - 5.6	N/A		20.0 - 23.0	6.1 - 7
RIHVN 150	18.5 - 22.5	5.6 - 6.9	15.5 - 20.0	4.7 - 6.1	24.0 - 27.5	7.3 - 8.4	21.5 - 24.5	6.6 - 7.5
RIHVN 160*	19.0 - 23.0	5.8 - 7.0	17.0 - 20.5	5.2 - 6.2	25.0 - 28.5	7.6 - 8.7	22.5 - 25.5	6.9 - 7.8
RIHVN 200	20.5 - 25.0	6.2 - 7.6	18.5 - 22.5	5.6 - 6.9	27.0 - 31.0	8.2 - 9.4	24.5 - 28.0	7.5 - 8.5

\*Must be within allowable mounting angle range.

## Sample Specifications

### Models RIH/RIHV - High Intensity Infrared Heaters

Provide gas-fired, high-intensity infrared heaters manufactured as Reznor brand units. The heaters shall be equipped for use with natural (propane) gas to operate on a 115 volt supply voltage [25 volt supply voltage].

The burner control system shall have a direct spark ignition with 100% safety shut-off and a solenoid gas valve with 1/2" NPT inlet. Heater shall have single-stage [two-stage] heating.

Heaters shall be of compact modular design and rugged construction consisting of the controls; a seamless aluminized steel plenum chamber with stainless steel ceramic tile retainer clips; surface combustion ceramic burner capable of full intensity temperature in less than 30 seconds; venturi mixer of spun metal construction for precision metering of air/gas mixture; highly polished aluminum reflector; and balanced suspension holes.

The burner assembly shall be removable with a single screw for cleaning or replacement. The ceramic combustion surface shall reach temperatures up to 1850°F and be of a cordierite-based grooved design with alternating rows of precision perforations producing a shorter stable flame.

These units must be approved for installation in The United States and Canada by the Canadian Standards Association (CSA). (Capacities, dimensions, and additional field-installed options as described in this catalog.)

## Limited Warranty

### Model RIH/RIHV Heaters

Thomas & Betts warrants to the original owner-user that this Reznor product will be free from defects in material or workmanship. This warranty is limited to twelve (12) months from the date of original installation, whether or not actual use begins on that date, or eighteen (18) months from date of shipment by Reznor, whichever occurs first.

#### Limitations and Exclusions

Thomas & Betts Corporation's obligations under this warranty and the sole remedy for its breach are limited to repair, at its manufacturing facility, of any part or parts of its Reznor products which prove to be defective; or, in its sole discretion, replacement of such products. All returns of defective parts or products must include the product model number and serial number, and must be made through an authorized Reznor distributor or arranged through Reznor Customer Service. Authorized returns must be shipped prepaid. Repaired or replacement parts will be shipped by Thomas & Betts F.O.B. shipping point.

1. The warranty provided herein does not cover charges for labor or other costs incurred in the troubleshooting, repair, removal, installation, service or handling of parts or complete products.
2. All claims under the warranty provided herein must be made within ninety (90) days from the date of discovery of the defect. Failure to notify Thomas & Betts of a warranted defect within ninety (90) days of its discovery voids Thomas & Betts's obligations hereunder.
3. The warranty provided herein shall be void and of no effect in the event that (a) the product has been operated outside its designed output capacity (heating, cooling, airflow); (b) the product has been subjected to misuse, neglect, accident, improper or inadequate maintenance, corrosive environments, environments containing airborne contaminants (silicone, aluminum oxide, etc.), or excessive thermal shock; (c) unauthorized modifications are made to the product; (d) the product is not installed or operated in compliance with the manufacturer's printed instructions; (e) the product is not installed and operated in compliance with applicable building, mechanical, plumbing and electrical codes; or (f) the serial number of the product has been altered, defaced or removed.
4. The warranty provided herein is for repair or replacement only. Thomas & Betts Corporation shall not be liable for any loss, cost, damage, or expense of any kind arising out of a breach of the warranty. Further, Thomas & Betts Corporation shall not be liable for any incidental, consequential, exemplary, special, or punitive damages, nor for any loss of revenue, profit or use, arising out of a breach of this warranty or in connection with the sale, maintenance, use, operation or repair of any Reznor product. In no event will Thomas & Betts be liable for any amount greater than the purchase price of a defective product. The disclaimers of liability included in this paragraph 4 shall remain in effect and shall continue to be enforceable in the event that any remedy herein shall fail of its essential purpose.
5. THIS WARRANTY IS THE SOLE AND EXCLUSIVE WARRANTY FOR REZNOR PRODUCTS, AND IS IN LIEU OF ALL OTHER EXPRESS AND IMPLIED WARRANTIES. THOMAS & BETTS CORPORATION SPECIFICALLY DISCLAIMS ALL OTHER EXPRESS AND IMPLIED WARRANTIES, INCLUDING, BUT NOT LIMITED TO, ALL IMPLIED WARRANTIES OF MERCHANTABILITY AND FITNESS FOR A PARTICULAR PURPOSE. No person or entity is authorized to bind Thomas & Betts Corporation to any other warranty, obligation or liability for any Reznor product. Installation, operation or use of the Reznor product for which this warranty is issued shall constitute acceptance of the terms hereof.

## Reznor

### REZNOR SUPPORTS RADIANT HEATING

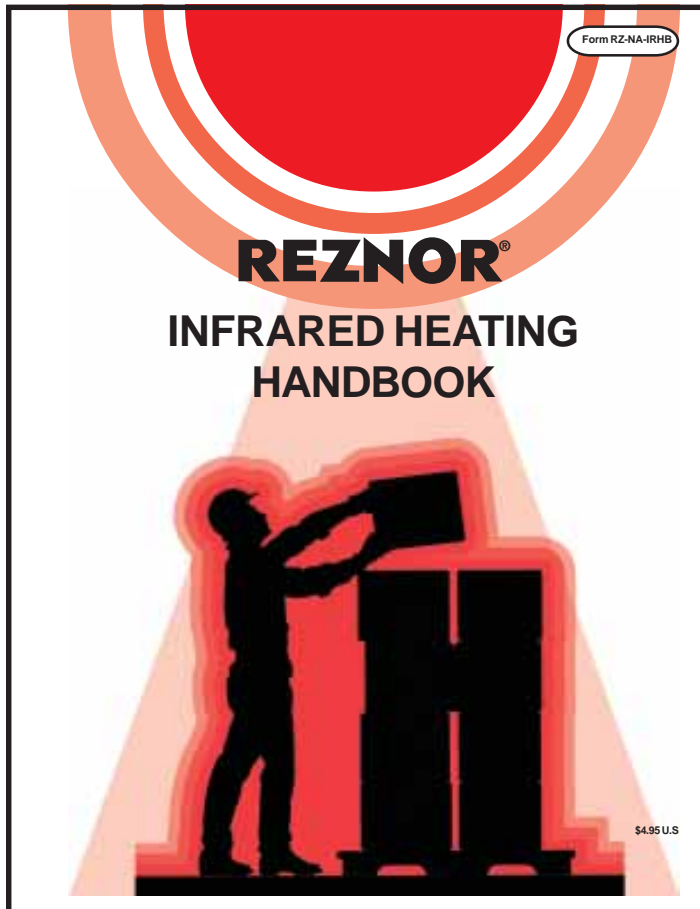

### Infrared Heating Handbook

Designed as a reference manual, Reznor's Infrared Heating Handbook begins with general information on radiant heat transfer and the development of radiant heating equipment. The information becomes more specific, explaining procedures for selecting and sizing both low-intensity and high-intensity infrared equipment. Examples illustrate equipment selection for both spot and space heating applications. Currently, this book is only available in PDF format on the Reznor web site: [www.RezSpec.com](http://www.RezSpec.com).

Contact your Reznor Representative for additional information on the Reznor Radiant Heater line of equipment. To reach your Reznor Representative, call 800-695-1901, then select option "1."

### ADVANTAGES OF HEATING WITH INFRARED

The Reznor commercial/industrial line of infrared heating equipment is designed to provide quiet, energy-efficient, comfort-level temperatures through application of radiant heat transfer. Radiant heat transfer means that heated infrared rays are radiated until those rays are absorbed by objects, such as floors, equipment, or people. Infrared heat rays do not warm the air; the air immediately surrounding the "heated" objects is warmed because of the increase in temperature of those objects. This makes infrared heating ideal for spot heating applications such as garage bays, assembly lines, loading docks, parking ramps, airplane hangars, and any other indoor loca-

tion where heat is needed in only a specific area. Since the infrared rays are absorbed by the floor, infrared heating provides warmer floor-level temperatures. Quieter, more energy-efficient operation is achieved because infrared heating equipment does not require fans or blowers. Reznor provides both low-intensity, tubular radiant heaters and high-intensity, surface combustion infrared heaters. For more detailed information on the technical applications of heating with infrared, consult the Infrared Heating Handbook found on the Reznor web site at [www.RezSpec.com](http://www.RezSpec.com). If unsure of a particular application, consult your Reznor Sales Representatives.

# Reznor<sup>®</sup> is your global source for heating, ventilating and air conditioning equipment.

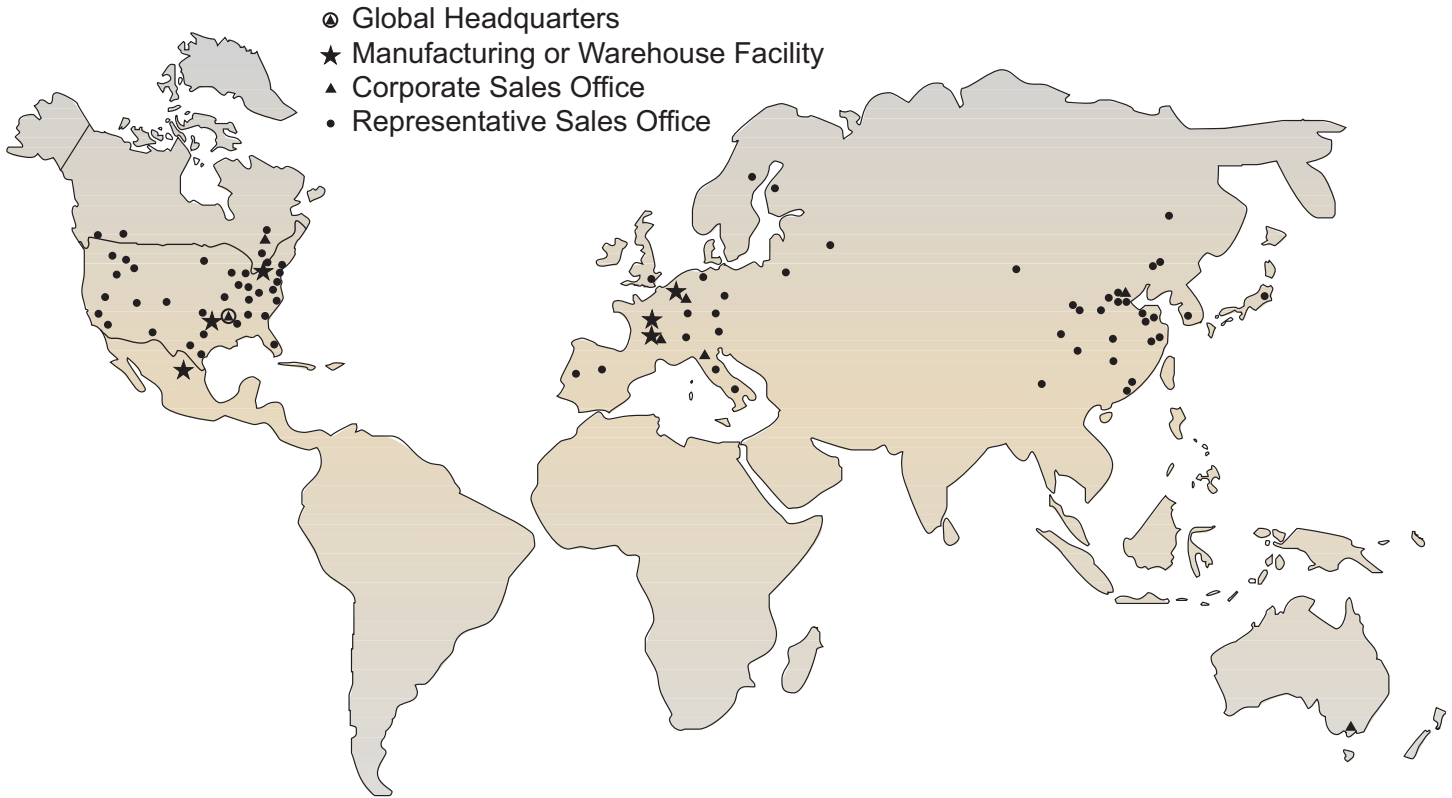

**For more information on Reznor HVAC Equipment,  
contact your local Reznor Representative by calling  
800-695-1901.**

**Or, find us on the internet at  
[www.RezSpec.com](http://www.RezSpec.com)**