

- GB** Bruciatori di gasolio
- E** Quemadores de gasóleo
- P** Queimadores a gasóleo

Two stage operation
Funcionamiento a dos llamas
Funcionamento a duas chamas



CODE - CÓDIGO	MODEL - MODELO	TYPE - TIPO
3473232	RL 28	652 T1
3473233	RL 28	652 T1
3474132	RL 38	653 T1
3474133	RL 38	653 T1
3474332	RL 38	653 T1
3474333	RL 38	653 T1
3474632	RL 50	654 T1
3474633	RL 50	654 T1

TECHNICAL DATA	page 2
Variants	2
Accessories	2
Burner description	3
Packaging - Weight	3
Max. dimensions	3
Standard equipment	3
Firing rates	4
Test boiler	4
INSTALLATION	5
Boiler plate	5
Blast tube length	5
Securing the burner to the boiler	5
Choice of nozzles per il 1° e 2° stadio	5
Nozzle assembly	6
Combustion head setting	6
Hydraulic system	7
Electrical system	8
Pump	10
Burner calibration	11
Burner operation	12
Final checks	13
Maintenance	13
Burner start-up cycle diagnostics	14
Resetting the control box and using diagnostics	14
Fault - Probable cause - Suggested remedy	15
Status (optional)	16

N.B.

Figures mentioned in the text are identified as follows:

- 1)(A) = part 1 of figure A, same page as text;
- 1)(A)p.3 = part 1 of figure A, page number 3.

NOTE

In conformity with Efficiency Directive 92/42/EEC the application of the burner on the boiler, adjustment and testing must be carried out observing the instruction manual of the boiler, including verification of the CO and CO₂ concentration in the flue gases, their temperatures and the average temperature of the water in the boiler.

TECHNICAL DATA

MODEL			RL 28	RL 38	RL 38	RL 50
TYPE			652 T1	653 T1	653 T1	654 T1
OUTPUT ⁽¹⁾	2nd stage	kW	166 - 332	237 - 450	237 - 450	296 - 593
DELIVERY ⁽¹⁾		Mcal/h	143 - 286	204 - 387	204 - 387	255 - 510
		kg/h	14 - 28	20 - 38	20 - 38	25 - 50
	1st stage	kW	95 - 166	118 - 237	118 - 237	148 - 296
		Mcal/h	82 - 143	102 - 204	102 - 204	127 - 255
		kg/h	8 - 14	10 - 20	10 - 20	12,5 - 25
FUEL			LIGHT OIL			
- Net calorific value		kWh/kg	11,8			
		Mcal/kg	10,2 (10.200 kcal/kg)			
- Density		kg/dm ³	0,82 - 0,85			
- Viscosity at 20 °C		mm ² /s max	6 (1,5 °E - 6 cSt)			
OPERATION			<ul style="list-style-type: none"> Intermittent (min. 1 stop in 24 hours). Two-stage (high and low flame) and single-stage (all - nothing). 			
NOZZLES		number	2			
STANDARD APPLICATIONS			Boilers: water, steam, diathermic oil			
AMBIENT TEMPERATURE		°C	0 - 40			
COMBUSTION AIR TEMPERATURE		°C max	60			
ELECTRICAL SUPPLY		V	230 ~ +/-10%		230 - 400 with neutral ~ +/-10%	
		Hz	50 - single-phase		50 - three-phase	
ELECTRIC MOTOR		rpm	2800	2800	2800	2800
		W	300	420	450	650
		V	220 - 240	220 - 240	220/240 - 380/415	220/240 - 380/415
		A	2,4	2,8	2,0 - 1,2	3,0 - 1,7
MOTOR CAPACITOR		µF/V	12,5/450	16/450		
IGNITION TRANSFORMER		V1 - V2	230 V - 2 x 5 kV			
		I1 - I2	1,9 A - 30 mA			
PUMP delivery (at 20 bar)		kg/h	45	67	67	88
pressure range		bar	10 - 18	4 - 18	4 - 18	4 - 18
fuel temperature		°C max	60	60	60	60
ELECTRICAL POWER CONSUMPTION		W max	370	600	560	750
ELECTRICAL PROTECTION			IP 44			
IN CONFORMITY WITH EEC DIRECTIVES			89/336 - 73/23 - 92/42 - 98/37			
NOISE LEVELS ⁽²⁾		dBA	68,0	70,0	70,0	75,0

(1) Reference conditions: Ambient temperature 20°C - Barometric pressure 1000 mbar - Altitude 100 m a.s.l.

(2) Sound pressure measured in manufacturers combustion laboratory, with burner operating on test boiler and at maximum rated output.

VARIANTS

Model	Code	Electrical supply	Blast tube length mm
RL 28	3473232	single-phase	216
	3473233	single-phase	351
RL 38	3474132	single-phase	216
	3474133	single-phase	351
	3474332	three-phase	216
	3474333	three-phase	351
RL 50	3474632	three-phase	216
	3474633	three-phase	351

ACCESSORIES (optional):

- **STATUS** (see page 16): code **3010321**

- **DEGASSING UNIT**

It may occur that a certain amount of air is contained in the light oil sucked up by the pump. This air may originate from the light oil itself as a consequence of depressurization or air leaking past imperfect seals.

In double-pipe systems, the air returns to the tank from the return pipe; in single-pipe systems, the air remains in circulation causing pressure variations in the pump and burner malfunctions.

For this reason, we advise installing a degassing unit near the burner in single-pipe installations.

Degassing units are provided in two versions:

CODE **3010054** without filter

CODE **3010055** with filter

Degassing unit characteristics

- Burner delivery : 80 kg/h max
- Light oil pressure : 0,7 bar max
- Ambient temperature : 40 °C max
- Light oil temperature : 40 °C max
- Attachment connectors : 1/4 inch

BURNER DESCRIPTION (A)

- 1 Ignition electrodes
- 2 Combustion head
- 3 Screw for combustion head adjustment
- 4 Photocell for flame presence control
- 5 Screw for fixing fan to flange
- 6 Slide bars for opening the burner and inspecting the combustion head
- 7 Hydraulic cylinder for regulation of the air gate valve in 1st and 2nd stage positions. When the burner is not operating the air gate valve is fully closed in order to reduce heat dispersion from the boiler due to the flue draught which draws air from the fan suction inlet.
- 8 Safety solenoid valve (RL 38 - RL 50)
- 9 Pump
- 10 Plate prearranged to drill 4 holes for the passage of hoses and electrical cables.
- 11 Air inlet to fan
- 12 Fan pressure test point
- 13 Boiler mounting flange
- 14 Flame stability disk
- 15 Flame inspection window
- 16 Extensions for slide bars 6)
- 17 Motor contactor and thermal cut-out reset button (RL 38 three-phase - RL 50)
- 18 Motor capacitor (RL 28 - RL 38 single-phase)
- 19 Control box with lock-out pilot light and lock-out reset button
- 20 Two switches:
 - one "burner off - on"
 - one for "1st - 2nd stage operation"
- 21 Plugs for electrical connections
- 22 Air gate valve
- 23 Pump pressure adjustment
- 24 1st and 2nd stage valve assembly

Two types of burner failure may occur:
Control box lock-out: if the control box 19)(A) pushbutton (red led) lights up, it indicates that the burner is in lock-out.
 To reset, hold the pushbutton down for between 1 and 3 seconds.
Motor trip (RL 38 three-phase - RL 50): release by pressing the pushbutton on thermal cutout 17)(A).

PACKAGING-WEIGHT (B)

Approximate measurements

- The burner is shipped in cardboard box with the maximum dimensions shown in table (B).
- The weight of the burner complete with packaging is indicated in table (B).

MAX. DIMENSIONS (C)

Approximate measurements.

The maximum dimensions of the burner are given in (C).

Bear in mind that inspection of the combustion head requires the burner to be opened and the rear part withdrawn on the slide bars.

The maximum dimension of the burner, without casing, when open is give by measurement H.

STANDARD EQUIPMENT

- 2 - Flexible hoses
- 2 - Gaskets for flexible hoses
- 2 - Nipples for flexible hoses
- 1 - Thermal insulation screen
- 2 - Extensions 16)(A) for slide bars 6)(A) (for model with 351 mm blast tube)
- 4 - Screws to secure the burner flange to the boiler: M 8 x 25
- 3 - Fairleads for electrical connections (RL 28 and 38 single-phase)
- 4 - Fairleads for electrical connections (RL 38 three-phase and RL 50)
- 1 - Instruction booklet
- 1 - Spare parts list

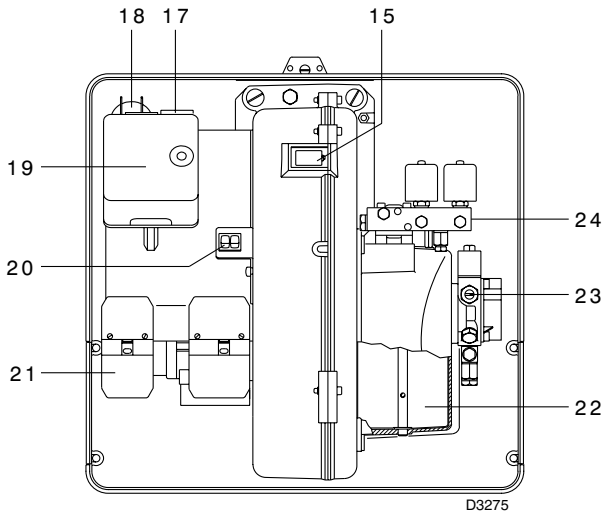
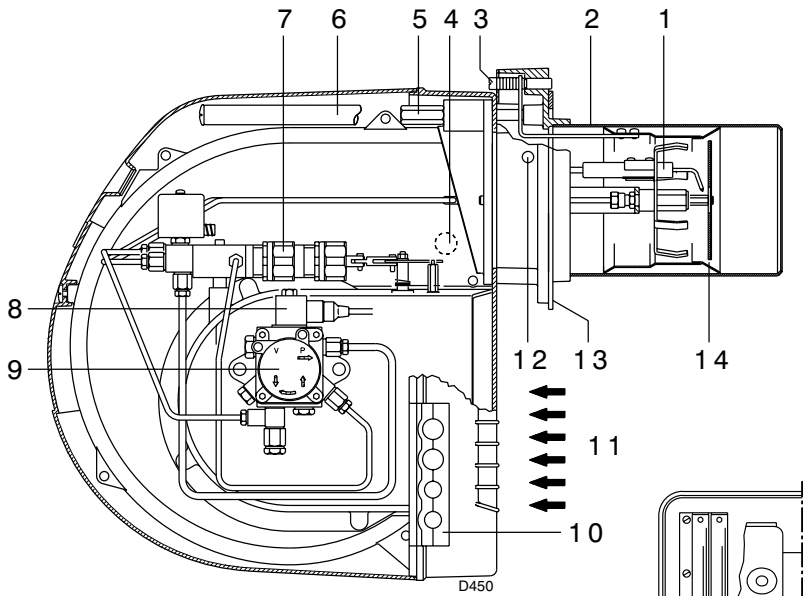

(A)

mm	A	B	C	kg
RL 28	1010	620	495	36
RL 38	1010	620	495	38
RL 50	1010	620	495	39

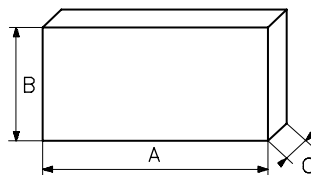

(B)

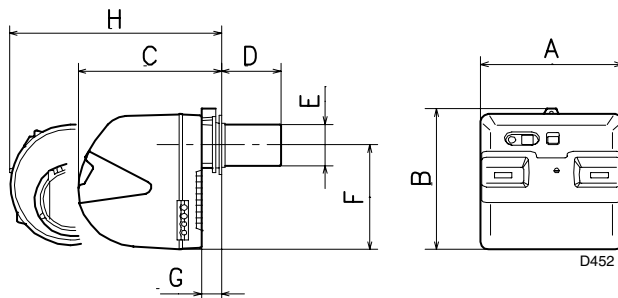

mm	A	B	C	D (1)	E	F	G	H (1)
RL 28	476	474	468	216 - 351	140	352	52	672 - 807
RL 38	476	474	468	216 - 351	140	352	52	672 - 807
RL 50	476	474	468	216 - 351	152	352	52	672 - 807

(1) Blast tube: short-lang

(C)

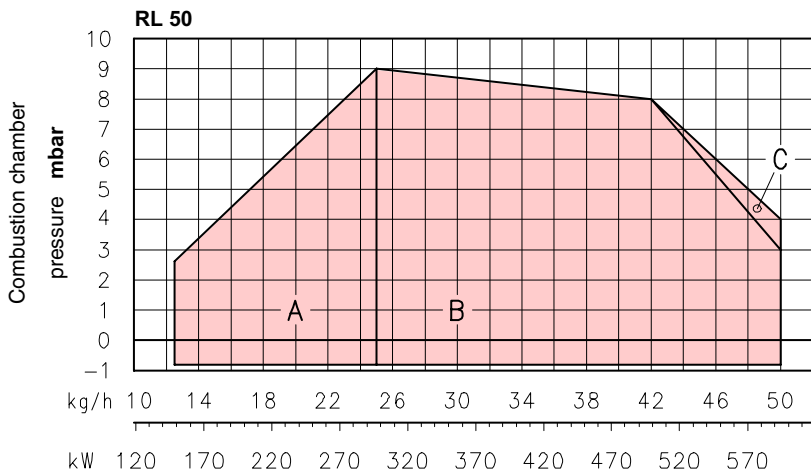
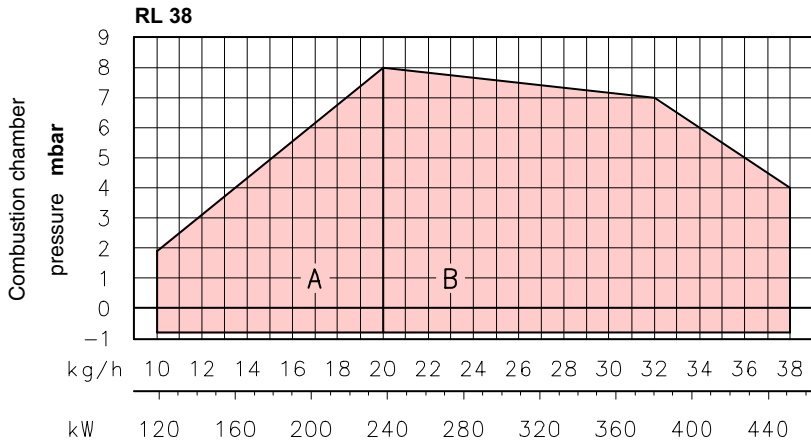
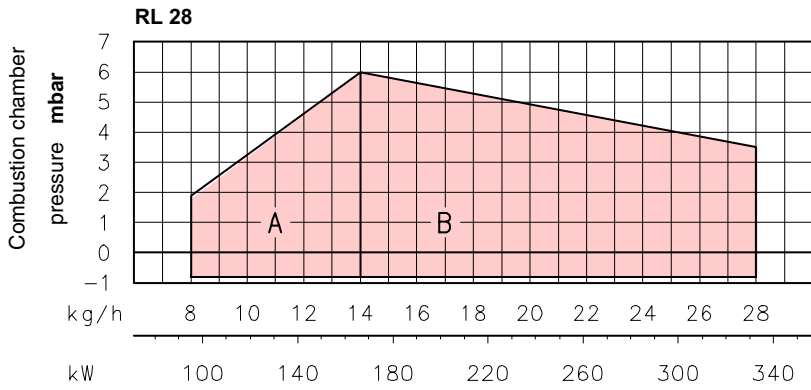

FIRING RATES (A)

The RL 28 - 38 - 50 Model burners can work in two ways: one-stage and two-stage.

1st stage DELIVERY must be selected within area A of the adjacent diagrams.

2nd stage DELIVERY must be selected within area B (and C for model RL 50). This area provides the maximum delivery of the burner in relation to the pressure in the combustion chamber.

The work point may be found by plotting a vertical line from the desired delivery and a horizontal line from the pressure in the combustion chamber. The intersection of these two lines is the work point which must lie within area B. In order to utilize also area C (RL 50) it is necessary to perform the calibration of the combustion head as explained on page 5.

Important

The FIRING RATE area values have been obtained considering a surrounding temperature of 20 °C, and an atmospheric pressure of 1000 mbar (approx. 100 m above sea level) and with the combustion head adjusted as shown on page 6.

TEST BOILER (B)

The firing rate was set in relation to special test boilers in accordance with the methods defined in EN 267 standards.

Figure (B) indicates the diameter and length of the test combustion chamber.

Example:

delivery 35 kg/hour:
diameter = 50 cm; length = 1,5 m.

Whenever the burner is operated in a much smaller commercially-available combustion chamber, a preliminary test should be performed.

(A)

D453

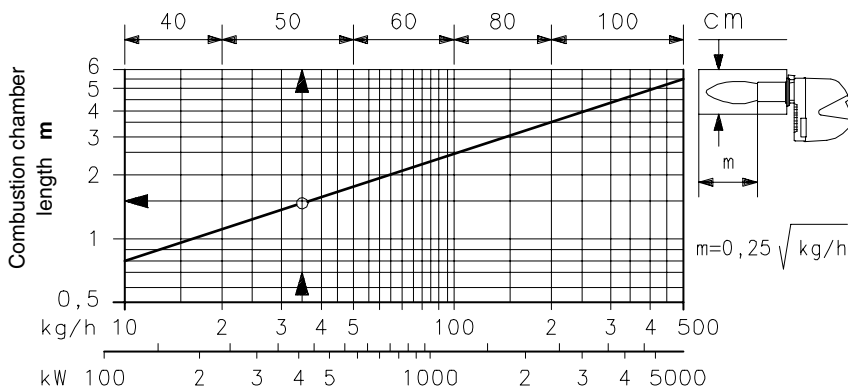

(B)

D454

INSTALLATION

BOILER PLATE (A)

Drill the combustion chamber locking plate as shown in (A).

The position of the threaded holes can be marked using the thermal screen supplied with the burner.

BLAST TUBE LENGTH (B)

The length of the blast tube must be selected according to the indications provided by the manufacturer of the boiler, and in any case it must be greater than the thickness of the boiler door complete with its fettling. The range of lengths available, L, is as follows:

Blast tube 7):	RL 28	RL 38	RL 50
• short	216	216	216
• long	351	351	351

For boilers with front flue passes 10) or flame inversion chambers, protective fettling in refractory material 8) must be inserted between the boiler's fettling 9) and the blast tube 7).

This protective fettling must not compromise the extraction of the blast tube.

For boilers having a water-cooled front the refractory fettling 8)-9)(B) is not required unless it is expressly requested by the boiler manufacturer.

SECURING THE BURNER TO THE BOILER (B)

Disassemble the blast tube 7) from the burner 4) by proceeding as follows:

- Remove the screws 2) from the two slide bars 3).
- Remove the screw 1) fixing the burner 4) to the flange 5).
- Withdraw the blast tube 7) complete with flange 5) and slide bars 3).

COMBUSTION HEAD CALIBRATION

At this point check, for model RL 50, whether the maximum delivery of the burner in 2nd stage operation is contained in area B or in area C of the firing rate. See page 4.

If it is in area B then no operation is required.

If, on the other hand, it is in area C:

- Unscrew the screws 1)(C) and disassemble the blast tube 2).
- Move the fixing of the rod 3)(C) from position A to position B, thereby causing the shutter 4) to retract.
- Now refit the blast tube 2)(C) and the screws 1).

Once this operation has been carried out (if it was required), secure flange 5)(B) to the boiler plate interposing the supplied gasket 6). Use the 4 supplied screws provided after having protected the thread with anticruffing products (high-temperature grease, compounds, graphite).

The burner-boiler seal must be airtight.

CHOICE OF NOZZLES FOR 1st AND 2nd STAGE

Both nozzles must be chosen from among those listed in Table (D).

The first nozzle determines the delivery of the burner in the 1st stage.

The second nozzle works together with the 1st nozzle to determine the delivery of the burner in the 2nd stage.

The deliveries of the 1st and 2nd stages must be contained within the value range indicated on page 2. Use nozzles with a 60° spray angle at the recommended pressure of 12 bar

The two nozzles usually have equal deliveries, but the 1st stage nozzle may have the following specifications if required:

- a delivery less than 50% of the total delivery whenever the back-pressure peak must be reduced at the moment of firing;
- a delivery higher than 50% of the total delivery whenever the combustion during the 1st stage must be improved.

mm	A	B	C
RL 28	160	224	M 8
RL 38	160	224	M 8
RL 50	160	224	M 8

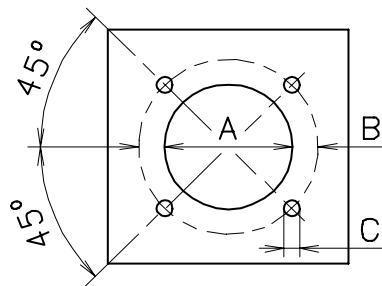

(A)

D455

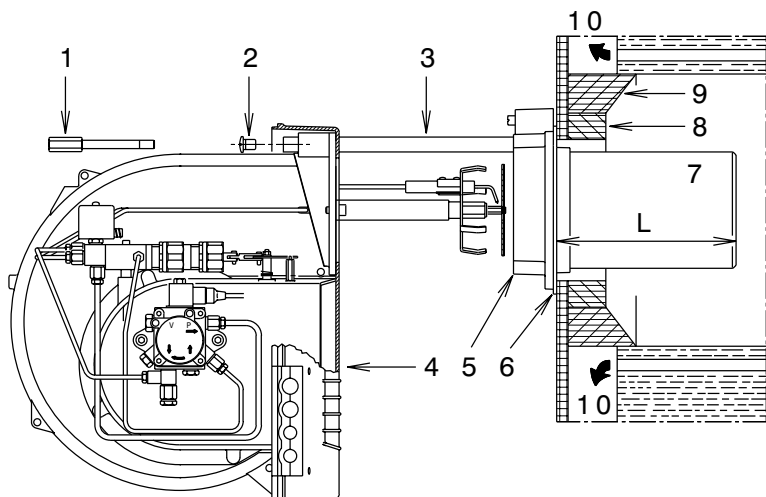

(B)

D456

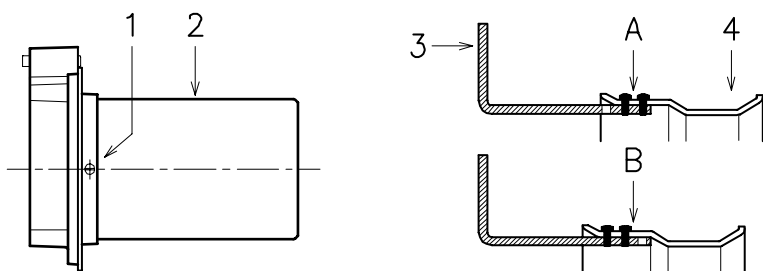

(C)

D457

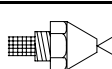
 60	GPH	kg/h (1)			kW 12 bar
		10 bar	12 bar	14 bar	
RL 28	2,00	7,7	8,5	9,2	100,8
	2,25	8,6	9,5	10,4	112,7
	2,50	9,6	10,6	11,5	125,7
	3,00	11,5	12,7	13,8	150,6
	3,50	13,5	14,8	16,1	175,5
RL 38	2,50	9,6	10,6	11,5	125,7
	3,00	11,5	12,7	13,8	150,6
	3,50	13,5	14,8	16,1	175,5
	4,00	15,4	17,0	18,4	201,6
	4,50	17,3	19,1	20,7	226,5
RL 50	5,00	19,2	21,2	23,0	251,4
	3,00	11,5	12,7	13,8	150,6
	3,50	13,5	14,8	16,1	175,5
	4,00	15,4	17,0	18,4	201,6
	4,50	17,3	19,1	20,7	226,5
	5,00	19,2	21,2	23,0	251,4
	5,50	21,1	23,3	25,3	276,3
	6,00	23,1	25,5	27,7	302,4

(1) light oil: density 0,84 kg/dm³
viscosity 4,2 cSt/20 °C
temperature 10 °C

(D)

(D)

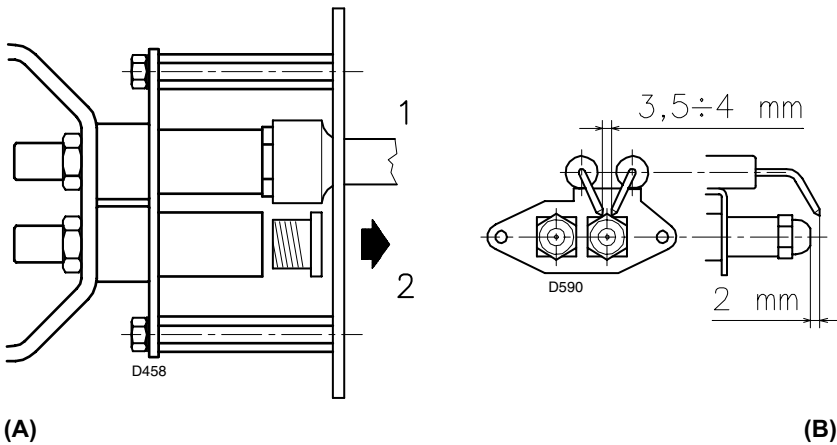

(A)

(B)

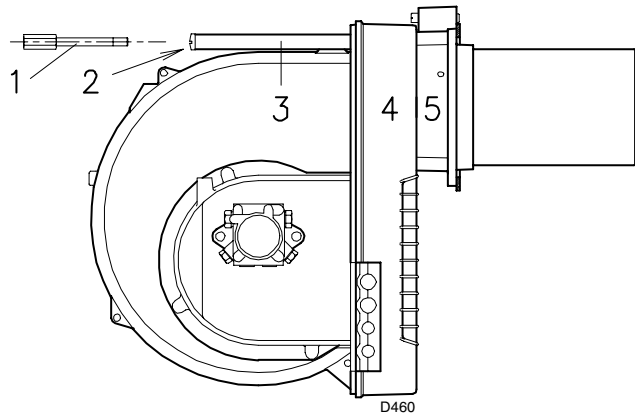

(C)

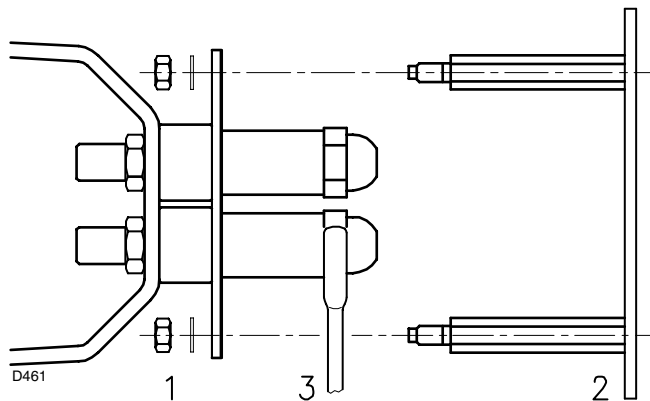

(D)

COMBUSTION HEAD SETTING

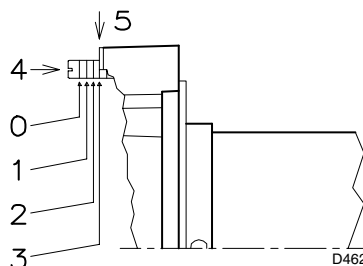

(E)

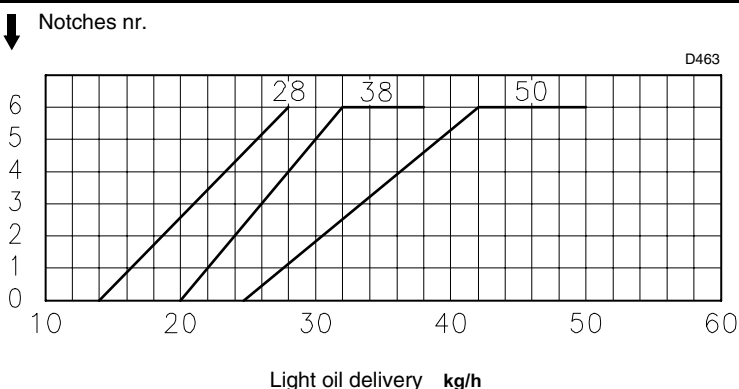

(F)

Example with RL 38

Boiler output = 270 kW - efficiency 90 %

Output required by the burner =

$$270 : 0,9 = 300 \text{ kW}$$

$$300 : 2 = 150 \text{ kW per nozzle}$$

therefore, two equal, 60°, 12 bar nozzles are required:

$$1^\circ = 3,00 \text{ GPH} - 2^\circ = 3,00 \text{ GPH},$$

or the following two different nozzles:

$$1^\circ = 2,50 \text{ GPH} - 2^\circ = 3,50 \text{ GPH},$$

or:

$$1^\circ = 3,50 \text{ GPH} - 2^\circ = 2,50 \text{ GPH}.$$

NOZZLE ASSEMBLY

At this stage of installation the burner is still disassembled from the blast tube; it is therefore possible to fit two nozzles with the box spanner 1)(A) (16 mm), after having removed the plastic plugs 2)(A), fitting the spanner through the central hole in the flame stability disk. Do not use any sealing products such as gaskets, sealing compound, or tape. Be careful to avoid damaging the nozzle sealing seat. The nozzles must be screwed into place tightly but not to the maximum torque value provided by the wrench.

The nozzle for the 1st stage of operation is the one lying beneath the firing electrodes fig. (B).

Make sure that the electrodes are positioned as shown in fig. (B).

Finally remount the burner 4)(C) to the slide bars 3) and slide it up to the flange 5), keeping it slightly raised to prevent the flame stability disk from pressing against the blast tube.

Tighten the screws 2) on the slide bars 3) and screw 1) that attaches the burner to the flange.

If it proves necessary to change a nozzle with the burner already fitted to the boiler, proceed as outlined below:

- Retract the burner on its slide bars as shown in fig. (B)p.5.
- Remove the nuts 1)(D) and the disk 2).
- Use spanner 3)(D) to change the nozzles.

COMBUSTION HEAD SETTING

The setting of the combustion head depends exclusively on the delivery of the burner in the 2nd stage - in other words, the combined delivery of the two nozzles selected on page 6.

Turn screw 4)(E) until the notch shown in diagram (F) is level with the front surface of flange 5)(E).

Example:

The RL 38 Model with two 3.00 GPH nozzles and 12 bar pump pressure.

Find the delivery of the two 3.00 GPH nozzles in table (D), page 5:

$$12,7 + 12,7 = 25,4 \text{ kg/h}.$$

Diagram (F) indicates that for a delivery of 25.4 kg/h the RL 38 model requires the combustion head to be set to approx. three notches, as shown in fig. (E).

HYDRAULIC SYSTEM

FUEL SUPPLY

Double-pipe circuit (A)

The burner is equipped with a self-priming pump which is capable of feeding itself within the limits listed in the table at the side.

The tank higher than the burner A

The distance "P" must not exceed 10 meters in order to avoid subjecting the pump's seal to excessive strain; the distance "V" must not exceed 4 meters in order to permit pump self-priming even when the tank is almost completely empty.

The tank lower than the burner B

Pump depression values higher than 0.45 bar (35 cm Hg) must not be exceeded because at higher levels gas is released from the fuel, the pump starts making noise and its working life-span decreases.

It is good practice to ensure that the return and suction lines enter the burner from the same height; in this way it will be less probable that the suction line fails to prime or stops priming.

The loop circuit

A loop circuit consists of a loop of piping departing from and returning to the tank with an auxiliary pump that circulates the fuel under pressure. A branch connection from the loop goes to feed the burner. This circuit is extremely useful whenever the burner pump does not succeed in self-priming because the tank distance and/or height difference are higher than the values listed in the table.

Key (A)

H = Pump/Foot valve height difference

L = Piping length

Ø = Inside pipe diameter

1 = Burner

2 = Pump

3 = Filter

4 = Manual on/off valve

5 = Suction line

6 = Foot valve

7 = Rapid closing manual valve remote controlled (only Italy)

8 = On/off solenoid valve (only Italy)

9 = Return line

10 = Check valve (only Italy)

HYDRAULIC CONNECTIONS (B)

The pumps are equipped with a by-pass that connects return line with suction line. The pumps are installed on the burner with the by-pass closed by screw 6(B)p.12.

It is therefore necessary to connect both hoses to the pump.

The pump will break down immediately if it is run with the return line closed and the by-pass screw inserted.

Remove the plugs from the suction and return connections of the pump.

Insert the hose connections with the supplied seals into the connections and screw them down.

Take care that the hoses are not stretched or twisted during installation.

Route the hoses through the holes in the plate, preferably using those on the rh side, fig. (B): unscrew the screws 1), now divide the insert piece into its two parts 2) and 3) and remove the thin diaphragm blocking the two passages 4).

Install the hoses where they cannot be stepped on or come into contact with hot surfaces of the boiler.

Now connect the other end of the hoses to the supplied nipples, using two wrenches, one to hold the nipple steady while using the other one to turn the rotary union on the hose.

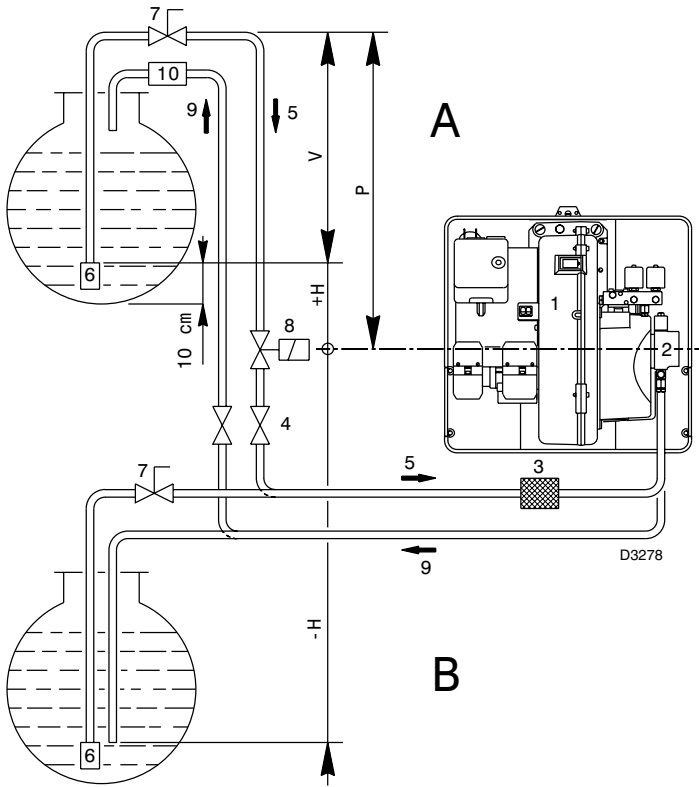

+ H - H (m)	L (m)								
	RL 28 Ø (mm)			RL 38 Ø (mm)			RL 50 Ø (mm)		
	8	10	12	8	10	12	10	12	14
+ 4,0	52	134	160	35	90	152	63	144	150
+ 3,0	46	119	160	30	80	152	55	127	150
+ 2,0	39	104	160	26	69	152	48	111	150
+ 1,0	33	89	160	21	59	130	40	94	150
+ 0,5	30	80	160	19	53	119	37	86	150
0	27	73	160	17	48	108	33	78	150
- 0,5	24	66	144	15	43	97	29	70	133
- 1,0	21	58	128	13	37	86	25	62	118
- 2,0	15	43	96	9	27	64	17	45	88
- 3,0	8	28	65	4	16	42	10	29	58
- 4,0	-	12	33	-	6	20	-	12	28

(A)

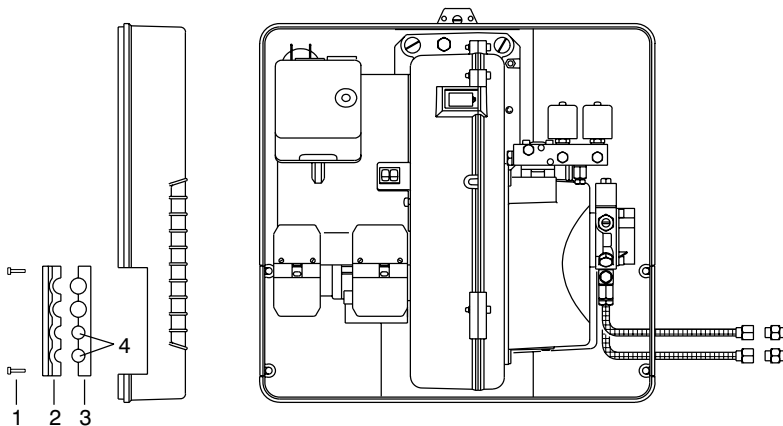

(B)

D3279

ELECTRICAL EQUIPMENT FACTORY-SET
RL 28

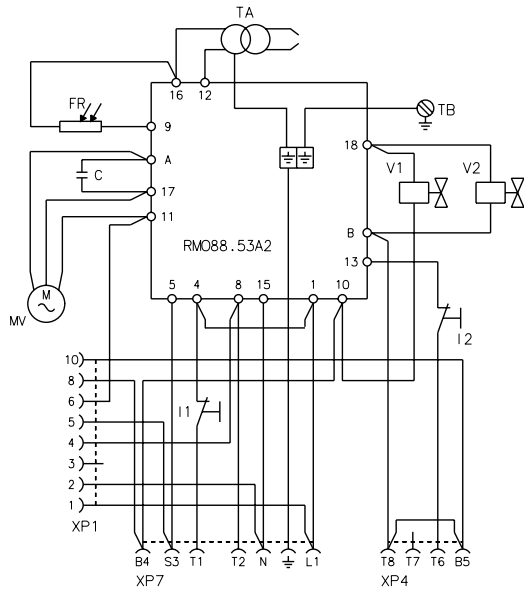

(A)

D3231

ELECTRICAL EQUIPMENT FACTORY-SET
RL 38 single-phase

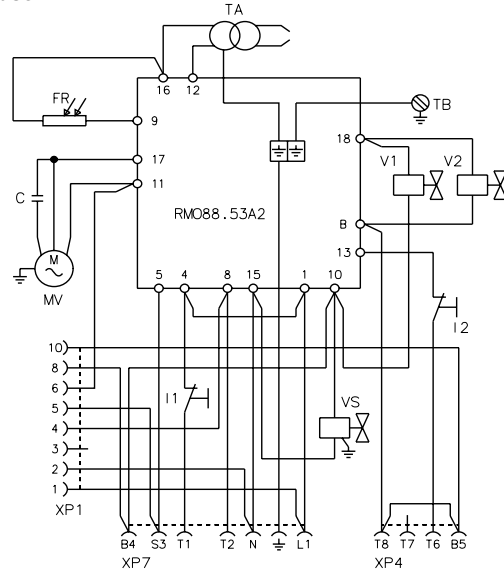

(B)

D3230

ELECTRICAL EQUIPMENT FACTORY-SET
RL 38 three-phase - RL 50

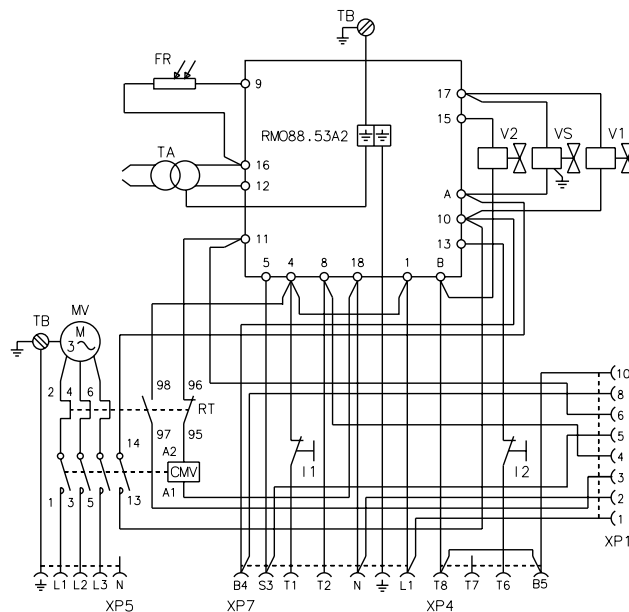

(C)

D3227

ELECTRICAL SYSTEM

ELECTRICAL SYSTEM as set up by the manufacturer

LAYOUT (A)
Burner RL 28 (single-phase)

LAYOUT (B)
Burner RL 38 (single-phase)

LAYOUT (C)
Burners RL 38 - 50 (three-phase)

- Models RL 38 three-phase and RL 50 leave the factory preset for **400 V** power supply.
- If **230 V** power supply is used, change the motor connection from star to delta and change the setting of the thermal cut-out as well.

Key to Layouts (A) - (B) - (C)

- | | |
|------------|--|
| C | - Capacitor |
| CMV | - Motor contactor |
| FR | - Photocell |
| I1 | - Switch:
burner off - on |
| I2 | - Switch:
1st - 2nd stage operation |
| MV | - Fan motor |
| RMO88.53A2 | - Control box |
| RT | - Thermal cut-out |
| TA | - Ignition transformer |
| TB | - Burner ground (earth) connection |
| V1 | - 1st stage solenoid valve |
| V2 | - 2nd stage solenoid valve |
| VS | - Safety solenoid valve |
| XP1 | - Connector for STATUS |
| XP4 | - 4 pole socket |
| XP5 | - 5 pole socket |
| XP7 | - 7 pole socket |

NOTE

For remote-reset, connect a push-button switch (NO) between terminal 4 and neutral of the control box (terminals 15, 16, 17 and 18).

ELECTRICAL CONNECTIONS

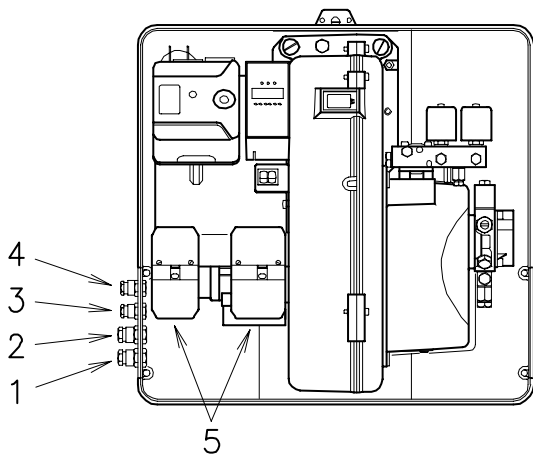

(A)

D465

ELECTRICAL CONNECTIONS
RL 28 - RL 38 single-phase

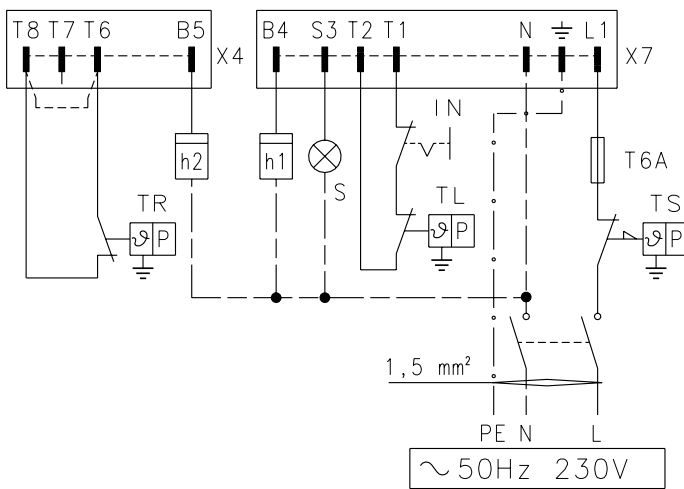

(B)

D3232

ELECTRICAL CONNECTIONS
RL 38 three-phase - RL 50

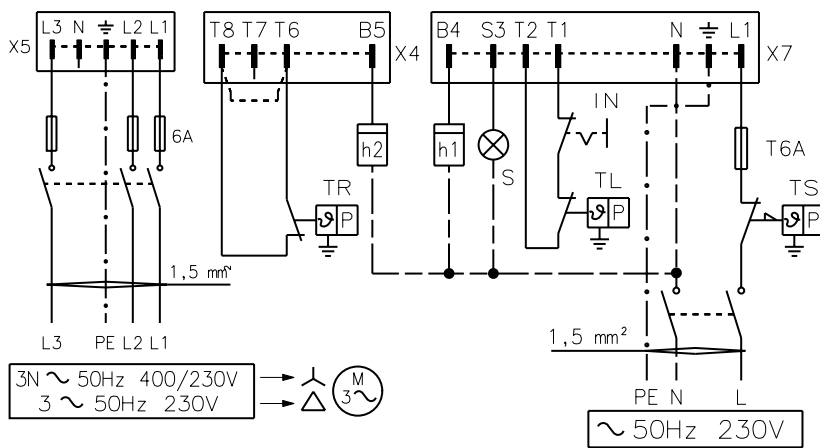

(C)

D3228

RL 38 - RL 50 three-phase CALIBRATION OF THERMAL RELAY

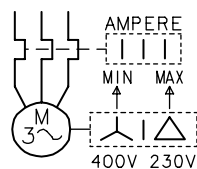

(D)

D867

ELECTRICAL CONNECTIONS (A)

set up by the installer
Use flexible cables according to regulation EN 60 335-1:

- if in PVC boot, use at least H05 VV-F
- if in rubber boot, use at least H05 RR-F.

All the cables to be connected to the burner sockets 5)(A) must be routed through the fair-leads, supplied by the manufacturer for insertion into the holes in the plate, preferably those on the left side, after having removed the thin diaphragm effectively closing the aperture, as already explained above.

- 1 - Pg 11 Three-phase power supply
- 2 - Pg 11 Single-phase power supply
- 3 - Pg 9 Control device TL
- 4 - Pg 9 Control device TR

LAYOUT (B)

The RL 28 - 38 Models electrical connection single-phase 230V power supply

Cable section not indicated: 1,5 mm²

LAYOUT (C)

The RL 38 - 50 Models electrical connection three-phase 230/400 V power supply with neutral phase wire

Cable section not indicated: 1,5 mm²

Key to wiring layouts (B) - (C)

- h1 - 1st stage hourcounter
- h2 - 2nd stage hourcounter
- IN - Manual burner stop switch
- X4 - 4 pole plug
- X5 - 5 pole plug
- X7 - 7 pole plug
- S - Remote lock-out signal
- TL - Limit control device system:
This shuts down the burner when the boiler temperature or pressure exceeds the set-point value.
- TR - High-low mode control device system:
This controls operating stages 1 and 2 and is necessary only for two-stage operation.
- TS - Safety control device system:
This operates when TL is faulty.

Important: the burner is factory set for two-stage operation and it must therefore be connected to the TR remove control device to command light oil valve V2. Alternatively, if single stage operation is required, instead of control device TR install a jumper lead between terminals T6 and T8 of connector X4.

LAYOUT (D)

Calibration of thermal cut-out 17)(A)p.3

This is required to avoid motor burn-out in the event of a significant increase in power absorption caused by a missing phase.

- If the motor is star-powered, **400 V**, the cursor should be positioned to "MIN".
- If the motor is delta-powered, **230 V**, the cursor should be positioned to "MAX".

Even if the scale of the thermal cut-out does not include rated motor absorption at 400 V, protection is still ensured in any case.

NOTES

- Burners RL 38 three-phase and RL 50 leave the factory preset for 400 V power supply. If 230 V power supply is used, change the motor connection from star to delta and change the setting of the thermal cutout as well.
- The RL 28 - 38 - 50 burners have been type-approved for intermittent operation. This means they should compulsorily be stopped at least once every 24 hours to enable the control box to perform checks of its own efficiency at start-up. Burner halts are normally provided for automatically by the boiler load control system.

WARNING:
Do not invert the neutral with the phase wire in the electricity supply line.

RL 28:
SUNTEC AN 57 C

RL 38: SUNTEC AL 65 C
RL 50: SUNTEC AL 75 C

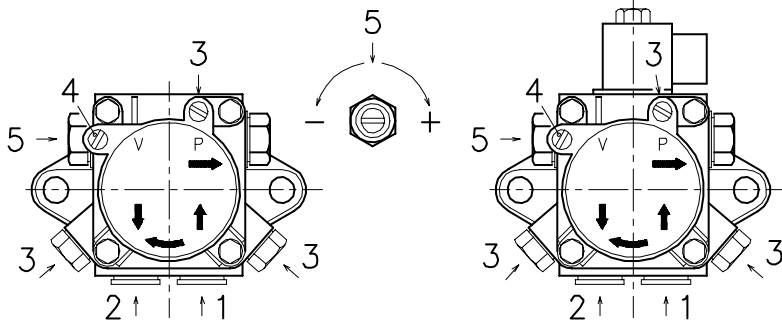

D481

PUMP (A)

- 1 - Suction G 1/4"
- 2 - Return G 1/4"
- 3 - Pressure gauge attachment G 1/8"
- 4 - Vacuum meter attachment G 1/8"
- 5 - Pressure adjustment screw

- A - Min. delivery rate at 12 bar pressure
- B - Delivery pressure range
- C - Max. suction depression
- D - Viscosity range
- E - Light oil max. temperature
- F - Max. suction and return pressure
- G - Pressure calibration in the factory
- H - Filter mesh width

PUMP PRIMING

- Before starting the burner, make sure that the tank return line is not clogged. Obstructions in the line could cause the sealing organ located on the pump shaft to break. (The pump leaves the factory with the by-pass closed).
- In order for self-priming to take place, one of the screws 3)(A) of the pump must be loosened in order to bleed off the air contained in the suction line.
- Start the burner by closing the control devices and with switch 1)(B)p.11 in the "ON" position. The pump must rotate in the direction of the arrow marked on the cover.
- The pump can be considered to be primed when the light oil starts coming out of the screw 3). Stop the burner: switch 1)(B)p.11 set to "OFF" and tighten the screw 3).

The time required for this operation depends upon the diameter and length of the suction tubing. If the pump fails to prime at the first starting of the burner and the burner locks out, wait approx. 15 seconds, reset the burner, and then repeat the starting operation as often as required. After 5 or 6 starting operations allow 2 or 3 minutes for the transformer to cool. Do not illuminate the photocell or the burner will lock out; the burner should lock out anyway about 10 seconds after it starts.

Important: the a.m. operation is possible because the pump is already full of fuel when it leaves the factory. If the pump has been drained, fill it with fuel through the opening on the vacuum meter prior to starting; otherwise, the pump will seize. Whenever the length of the suction piping exceeds 20-30 meters, the supply line must be filled using a separate pump.

PUMP		AN 57 C	AL 65 C	AL 75 C
A	kg/h	45	67	88
B	bar	10 - 18	4 - 18	4 - 18
C	bar	0,45	0,45	0,45
D	cSt	2 - 75	2 - 12	2 - 12
E	°C	60	60	60
F	bar	2	2	2
G	bar	12	12	12
H	mm	0,150	0,150	0,150

(A)

BURNER CALIBRATION

FIRING

Set switch 1)(B) to "ON".
 During the first firing, during the passage from the 1st to the 2nd stage, there is a momentary lowering of the fuel pressure caused by the filling of the 2nd stage nozzle tubing. This lowering of the fuel pressure can cause the burner to lock-out and can sometimes give rise to pulsations. Once the following adjustments have been made, the firing of the burner must generate a noise similar to the noise generated during operation. If one or more pulsations or a delay in firing in respect to the opening of the light oil solenoid valve occur, see the suggestions provided on p. 15: causes 34 to 42.

OPERATION

The optimum calibration of the burner requires an analysis of the flue gases at the boiler outlet and interventions on the following points:

• 1st and 2nd nozzles

See the information listed on page 5.

• Combustion head

The adjustment of the combustion head already carried out need not be altered unless the 2nd stage delivery of the burner is changed.

• Pump pressure

12 bar: This is the pressure calibrated in the factory which is usually sufficient for most purposes. Sometimes, this pressure must be adjusted to: **10 bar** in order to reduce fuel delivery. This adjustment is possible only if the surrounding temperature remains above 0°C. Never calibrate to pressures below 10 bar, at which pressures the cylinders may have difficulty in opening; **14 bar** in order to increase fuel delivery or to ensure firings even at temperatures of less than 0°C.

In order to adjust pump pressure, use the screw 5)(A), p. 10.

• 1st stage fan air gate valve

Keep the burner operating at 1st stage by setting the switch 2)(B) to the 1st stage position. Opening of the air gate valve 1)(A) must be adjusted in proportion to the selected nozzle: the index 7)(A) must be aligned with the specified in table (C). This adjustment is achieved by turning the hex element 4):

- in rh direction (- sign) the opening is reduced;
- in lh direction (+ sign) the opening increases.

Example RL 38 - 1st stage nozzle 3.00 GPH:

18° notch aligned with index 7)(A).

When the adjustment is terminated lock the hex element 4) with the ring nut 3).

• 2nd stage fan air gate valve

Set switch 2)(B) to the 2nd stage position and adjust the air gate valve 1)(A) by turning the hex element 6)(A), after having loosened the ring nut 5)(A).

Air pressure at attachment 1)(D) must be approximately the same as the pressure specified in table (D) plus the combustion chamber pressure measured at attachment 2). Refer to the example in the adjacent figure.

NOTE: in order to facilitate adjustment of hex elements 4) and 6)(A), use a 3 mmc Allen key 8)(A).

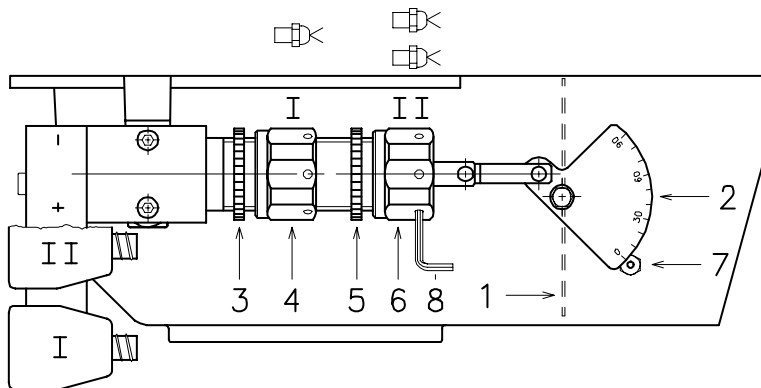

(A)

D468

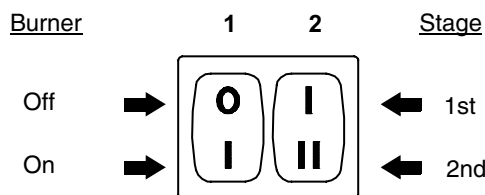

(B)

D469

1st STAGE

α = Notch Nr.

RL 28		RL 38		RL 50	
GPH	α	GPH	α	GPH	α
2,00	14	2,50	12	3,00	12
2,25	17	3,00	18	3,50	15
2,50	20	3,50	20	4,00	18
3,00	22	4,00	22	4,50	21
3,50	24	4,50	23	5,00	23
		5,00	26	5,50	27
				6,00	28

(C)

2nd STAGE

mbar = air pressure in 1) with zero pressure in 2)

(1) With shutter 4)(C)p.5 retracted

RL 28		RL 38		RL 50	
kg/h	mbar	kg/h	mbar	kg/h	mbar
14	6,0	20	7,0	25	6,1
16	6,3	22	7,0	29	6,2
18	6,6	24	7,0	33	6,4
20	6,8	26	7,0	37	6,5
22	7,1	29	7,0	41	6,6
24	7,6	32	7,0	45	8,0
26	8,4	35	8,0	50	10,1
28	8,8	38	9,4	50	9,1 (1)

(D)

BURNER OPERATION

BURNER STARTING (A) - (B)

Starting phases with progressive time intervals shown in seconds:

- Control device TL closes.
- After about 3s:
- 0 s : The control box starting cycle begins.
- 2 s : The fan motor starts.
- 3 s : The ignition transformer is connected.

The pump 3) sucks the fuel from the tank through the piping 1) and the filter 2) and pumps it under pressure to delivery. The piston 4) rises and the fuel returns to the tank through the piping 5) - 7). The screw 6) closes the by-pass heading towards suction and the solenoid valves 8) - 11) - 16), de-energized, close the passage to the nozzles.

The hydraulic cylinder 15), piston A, opens the air gate valve: pre-purging begins with the 1st stage air delivery.

- 22 s : Solenoid valves 8) and 16) open and the fuel passes through the piping 9) and filter 10) and is then sprayed out through the nozzle, igniting when it comes into contact with the spark. This is the 1st stage flame.
- 29 s : The ignition transformer switches off.
- 36 s : If the control device TR is closed or has been replaced by a jumper wire, the 2nd stage solenoid valve 11) is opened and the fuel enters the valve 12) and raises the piston which opens two passages: one to piping 13), filter 14), and the 2nd stage nozzle, and the other to the cylinder 15), piston B, that opens the fan air gate valve in the 2nd stage. The starting cycle comes to an end.

STEADY STATE OPERATION

System equipped with one control device TR
Once the starting cycle has come to an end, the command of the 2nd stage solenoid valve passes on to the control device TR that controls boiler temperature or pressure.

- When the temperature or the pressure increases until the control device TR opens, solenoid valve 11) closes, and the burner passes from the 2nd to the 1st stage of operation.
- When the temperature or pressure decreases until the control device TR closes, solenoid valve 11) opens, and the burner passes from the 1st to the 2nd stage of operation, and so on.
- The burner stops when the demand for heat is less than the amount of heat delivered by the burner in the 1st stage. In this case, the control device TL opens, and solenoid valves 8)-16) close, the flame immediately goes out. The fan's air gate valve closes completely.

Systems not equipped with control device TR (jumper wire installed)

The burner is fired as described in the case above. If the temperature or pressure increase until control device TL opens, the burner shuts down (Section A-A in the diagram).

When the solenoid valve 11) de-energizes, the piston 12) closes the passage to the 2nd stage nozzle and the fuel contained in the cylinder 15), piston B, is discharged into the return piping 7).

FIRING FAILURE

If the burner does not fire, it goes into lock-out within 5 s of the opening of the 1st nozzle valve and 30 s after the closing of control device TL.

The control box red pilot light will light up.

UNDESIRED SHUTDOWN DURING OPERATION

If the flame goes out during operation, the burner shuts down automatically within 1 second and automatically attempts to start again by repeating the starting cycle.

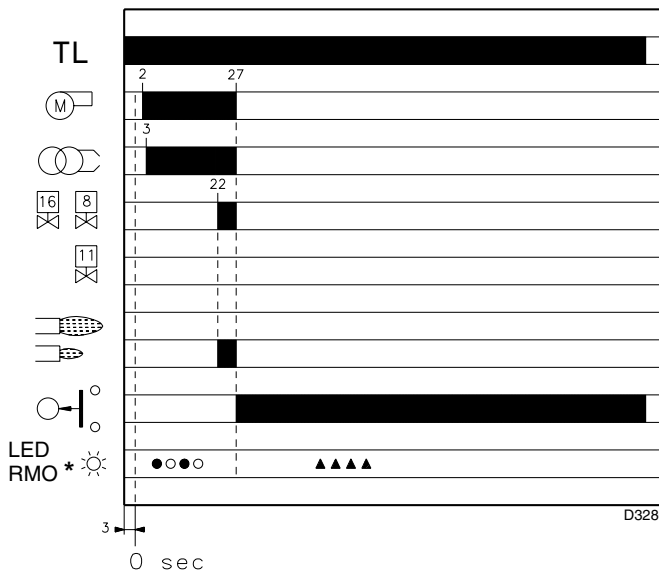
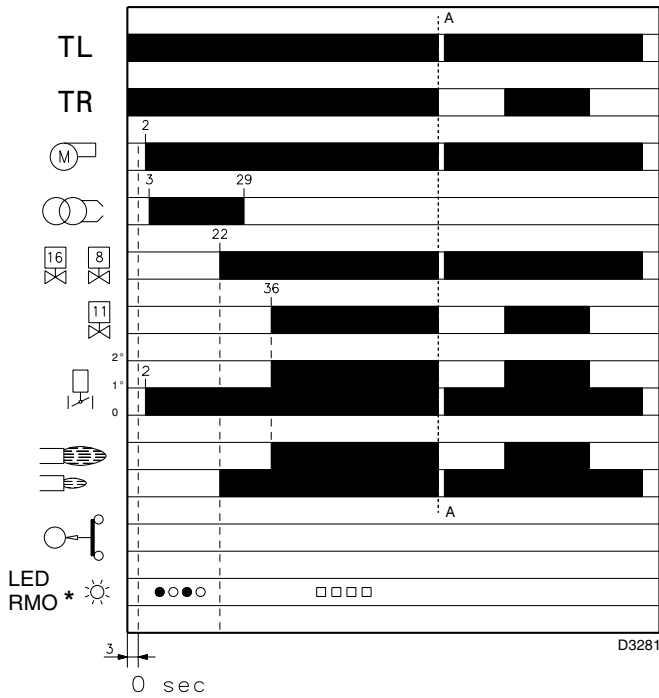

(A)

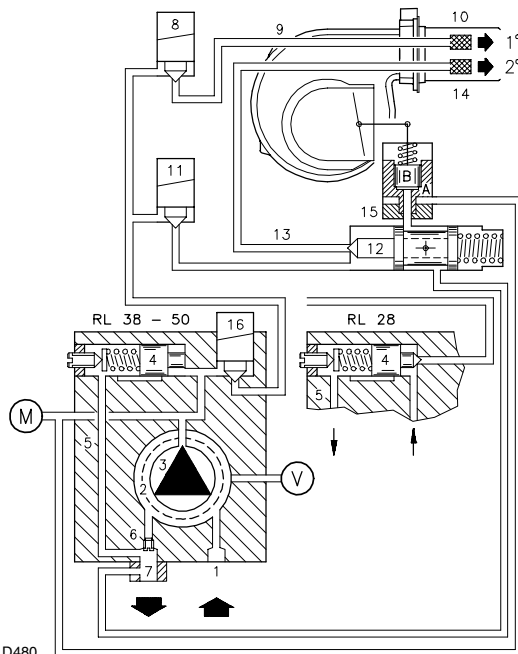

(B)

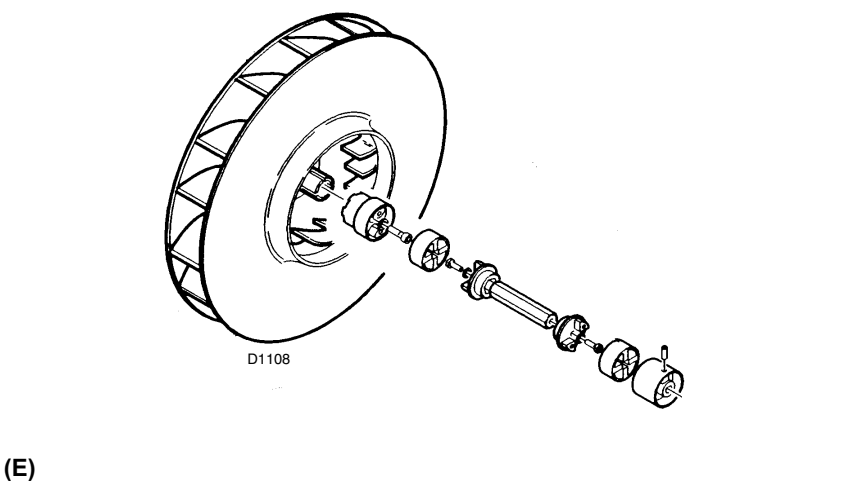
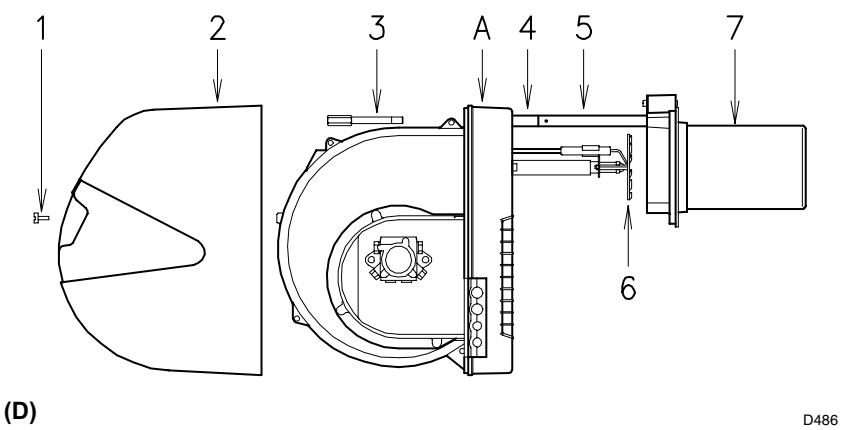
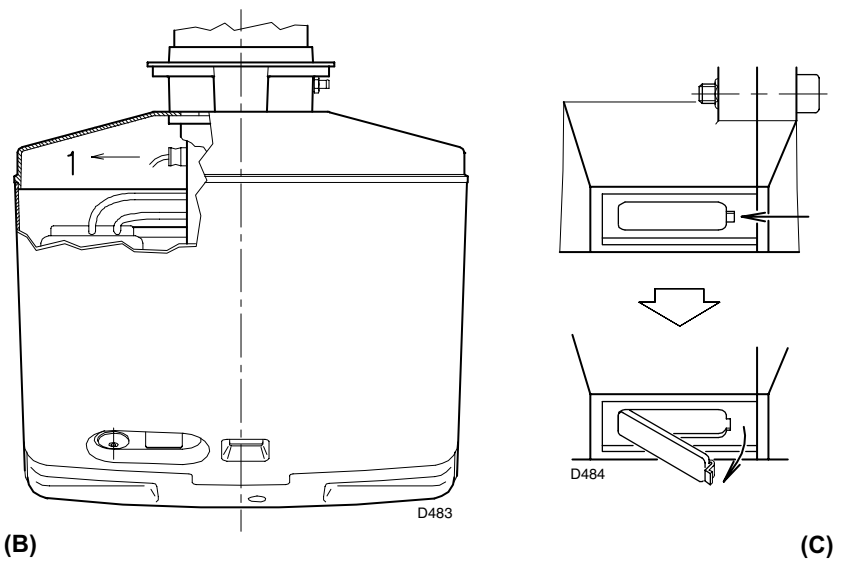
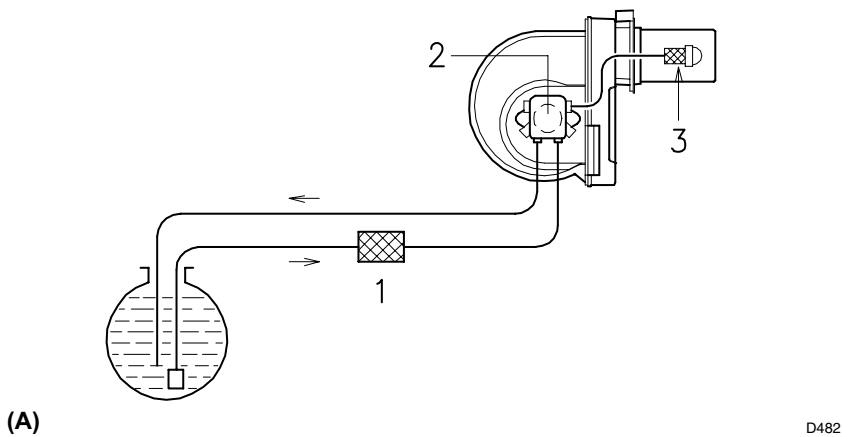

FINAL CHECKS

- Obscure the photocell and switch on the control devices: the burner should start and then lock-out about 5 s after opening of the 1st nozzle operation valve.
- Illuminate the photocell and switch on the control devices: the burner should start and then go into lock-out after about 10 s.
- Obscure the photocell while the burner is in 2nd stage operation, the following must occur in sequence: flame extinguished within 1 s, pre-purging for about 20 s, sparking for about 5 s, burner goes into lock-out.
- Switch off control device TL followed by control device TS while the burner is operating: the burner should stop.

MAINTENANCE

Combustion

The optimum calibration of the burner requires an analysis of the flue gases. Significant differences with respect to the previous measurements indicate the points where more care should be exercised during maintenance.

Pump

The delivery pressure must be stable at 12 bar.

The depression must be less than 0.45 bar.

Unusual noise must not be evident during pump operation.

If the pressure is found to be unstable or if the pump runs noisily, the flexible hose must be detached from the line filter and the fuel must be sucked from a tank located near the burner. This measure permits the cause of the anomaly to be traced to either the suction piping or the pump.

If the pump is found to be responsible, check to make sure that the filter is not dirty. The vacuum meter is installed upstream from the filter and consequently will not indicate whether the filter is clogged or not.

Contrarily, if the problem lies in the suction line, check to make sure that the filter is clean and that air is not entering the piping.

Filters (A)

Check the following filter boxes:

- on line 1) • in the pump 2) • at the nozzle 3), and clean or replace as required.

If rust or other impurities are observed inside the pump, use a separate pump to lift any water and other impurities that may have deposited on the bottom of the tank.

Then clean the insides of the pump and the cover sealing surface.

Fan

Check to make sure that no dust has accumulated inside the fan or on its blades, as this condition will cause a reduction in the air flow rate and provoke polluting combustion.

Combustion head

Check to make sure that all the parts of the combustion head are in good condition, positioned correctly, free of all impurities, and that no deformation has been caused by operation at high temperatures.

Nozzles

Do not clean the nozzle openings; do not even open them. The nozzle filters however may be cleaned or replaced as required.

Replace the nozzles every 2-3 years or whenever necessary.

Photocell (B)

Clean the glass cover from any dust that may have accumulated. Photocell 1) is held in position by a pressure fit and can therefore be removed by pulling it outward forcefully.

Flame inspection window (C)

Clean the glass whenever necessary.

Flexible hoses

Check to make sure that the flexible hoses are still in good condition and that they are not crushed or otherwise deformed.

Fuel tank

Approximately every 5 years, or whenever necessary, suck any water or other impurities present on the bottom of the tank using a separate pump.

Boiler

Clean the boiler as indicated in its accompanying instructions in order to maintain all the original combustion characteristics intact, especially the flue gas temperature and combustion chamber pressure.

TO OPEN THE BURNER (D)

- Switch off the electrical power
- Remove screw 1 and withdraw the casing 2)
- Unscrew screw 3)
- Fit the two extensions 4) supplied with the burner onto the slide bars 5) (model with 351 mm blast tube)
- Pull part A backward keeping it slightly raised to avoid damaging the disk 6) on blast tube 7).

Fuel pump and/or couplings replacement (E)

In conformity with fig. (E).

BURNER START-UP CYCLE DIAGNOSTICS

During start-up, indication is according to the following table:

COLOUR CODE TABLE	
Sequences	Colour code
Pre-purging	● ○ ● ○ ● ○ ● ○ ●
Ignition phase	● ○ ● ○ ● ○ ● ○ ●
Operation, flame ok	□ □ □ □ □ □ □ □ □
Operating with weak flame signal	□ ○ □ ○ □ ○ □ ○ □
Electrical supply lower than ~ 170V	● ▲ ● ▲ ● ▲ ● ▲ ●
Lock-out	▲ ▲ ▲ ▲ ▲ ▲ ▲ ▲ ▲
Extraneous light	▲ □ ▲ □ ▲ □ ▲ □ ▲
Key:	○ Off ● Yellow □ Green ▲ Red

RESETTING THE CONTROL BOX AND USING DIAGNOSTICS

The control box features a diagnostics function through which any causes of malfunctioning are easily identified (indicator: **RED LED**). To use this function, you must wait at least 10 seconds once it has entered the safety condition (**lock-out**), and then press the reset button. The control box generates a sequence of pulses (1 second apart), which is repeated at constant 3-second intervals. Once you have seen how many times the light pulses and identified the possible cause, the system must be reset by holding the button down for between 1 and 3 seconds.

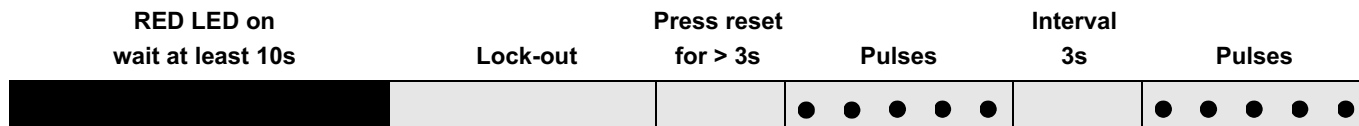

The methods that can be used to reset the control box and use diagnostics are given below.

RESETTING THE CONTROL BOX

To reset the control box, proceed as follows:

- Hold the button down for between 1 and 3 seconds.
The burner restarts after a 2-second pause once the button is released.
If the burner does not restart, you must make sure the limit thermostat is closed.

VISUAL DIAGNOSTICS

Indicates the type of burner malfunction causing lock-out.

To view diagnostics, proceed as follows:

- Hold the button down for more than 3 seconds once the red LED (burner lock-out) remains steadily lit.
A yellow light pulses to tell you the operation is done.
Release the button once the light pulses. The number of times it pulses tells you the cause of the malfunction, according to the coding system indicated in the table on page 15.

SOFTWARE DIAGNOSTICS

Reports burner life by means of an optical link with the PC, indicating hours of operation, number and type of lock-outs, serial number of control box etc ...

To view diagnostics, proceed as follows:

- Hold the button down for more than 3 seconds once the red LED (burner lock-out) remains steadily lit.
A yellow light pulses to tell you the operation is done.
Release the button for 1 second and then press again for over 3 seconds until the yellow light pulses again.
Once the button is released, the red LED will flash intermittently with a higher frequency: only now can the optical link be activated.

Once the operations are done, the control box's initial state must be restored using the resetting procedure described above.

BUTTON PRESSED FOR	CONTROL BOX STATUS
Between 1 and 3 seconds	Control box reset without viewing visual diagnostics.
More than 3 seconds	Visual diagnostics of lock-out condition: (LED pulses at 1-second intervals).
More than 3 seconds starting from the visual diagnostics condition	Software diagnostics by means of optical interface and PC (hours of operation, malfunctions etc. can be viewed)

The sequence of pulses issued by the control box identifies the possible types of malfunction, which are listed in the table on page 15.

SIGNAL	FAULT	PROBABLE CAUSE	SUGGESTED REMEDY
No blink	The burner does not start	1 - No electrical power supply 2 - A limit or safety control device is open 3 - Control box lock-out 4 - Pump is jammed 5 - Erroneous electrical connections 6 - Defective control box 7 - Defective electrical motor 8 - Defective capacitor (RL 28 - RL 38 single-phase)	Close all switches - Check fuses Adjust or replace Reset control box (no sooner than 10 s after the lock-out) Replace Check connections Replace Replace Replace
4 x blinks ● ● ● ●	The burner starts and then goes into lock-out	9 - Photocell short-circuit 10 - Light is entering or flame is simulated	Replace photocell Eliminate light or replace control box
2 x blinks ● ●	After pre-purge and the safety time, the burner goes to lock-out at the end of the safety time	11 - No fuel in tank; water on tank bottom 12 - Inappropriate head and air damper adjustments 13 - Light oil solenoid valves fail to open (1st stage or safety) 14 - 1st nozzle clogged, dirty, or deformed 15 - Dirty or poorly adjusted firing electrodes 16 - Grounded electrode due to broken insulation 17 - High voltage cable defective or grounded 18 - High voltage cable deformed by high temperature 19 - Ignition transformer defective 20 - Erroneous valves or transformer electrical connections 21 - Control box defective 22 - Pump unprimed 23 - Pump/motor coupling broken 24 - Pump suction line connected to return line 25 - Valves up-line from pump closed 26 - Filters dirty: line - pump - nozzle 27 - Defective photocell or control box 28 - Dirty photocell 29 - 1st stage operation of cylinder is faulty 30 - Motor protection tripped (RL 38 three-phase - RL 50) 31 - Defective motor command control device (RL 38 three-phase - RL 50) 32 - Missing phase (RL 38 three-phase - RL 50) 33 - Incorrect motor rotation direction	Top up fuel level or suck up water Adjust, see page 6 and 11 Check connections; replace coil Replace Adjust or clean Replace Replace Replace and protect Replace Check Replace Prime pump and see "Pump unprimed" Replace Correct connection Open Clean Replace photocell or control box Clean Change the cylinder Reset thermal cut-out Replace Reset thermal cut-out when third phase is re-connected Change motor electrical connections
7 x blinks ● ● ● ● ● ● ●	Flame detachment	34 - Poorly adjusted head 35 - Poorly adjusted or dirty firing electrodes 36 - Poorly adjusted fan air gate: too much air 37 - 1st nozzle is too big (pulsation) 38 - 1st nozzle is too small (flame detachment) 39 - 1st nozzle dirty, or deformed 40 - Inappropriate pump pressure 41 - 1st stage nozzle unsuited to burner or boiler 42 - Defective 1st stage nozzle	Adjust, see page 6, fig. (F) Adjust, see page 6, fig. (B) Adjust Reduce 1st nozzle delivery Increase 1st nozzle delivery Replace Adjust to between 10 and 14 bar See Nozzle Table, page 5; reduce 1st stage Replace
	The burner does not pass to 2nd stage	43 - Control device TR does not close 44 - Defective control box 45 - 2nd stage sol. valve coil defective 46 - Piston jammed in valve unit	Adjust or replace Replace Replace Replace entire unit
	Fuel passes to 2nd stage but air remains in 1st	47 - Low pump pressure 48 - 2nd stage operation of cylinder is faulty	Increase Change cylinder
	Burner stops at transition between 1st and 2nd stage. Burner repeats starting cycle.	49 - Nozzle dirty 50 - Photocell dirty 51 - Excess air	Renew nozzle Clean Reduce
	Uneven fuel supply	52 - Check if cause is in pump or fuel supply system	Feed burner from tank located near burner
	Internally rusted pump	53 - Water in tank	Suck water from tank bottom with separate pump
	Noisy pump, unstable pressure	54 - Air has entered the suction line - Depression value too high (higher than 35 cm Hg): 55 - Tank/burner height difference too great 56 - Piping diameter too small 57 - Suction filters clogged 58 - Suction valves closed 59 - Paraffin solidified due to low temperature	Tighten connectors Feed burner with loop circuit Increase Clean Open Add additive to light oil
	Pump unprimed after prolonged pause	60 - Return pipe not immersed in fuel 61 - Air enters suction piping	Bring to same height as suction pipe Tighten connectors
	Pump leaks light oil	62 - Leakage from sealing organ	Replace pump
	Smoke in flame - dark Bacharach - yellow Bacharach	63 - Not enough air 64 - Nozzle worn or dirty 65 - Nozzle filter clogged 66 - Erroneous pump pressure 67 - Flame stability spiral dirty, loose, or deformed 68 - Boiler room air vents insufficient 69 - Too much air	Adjust head and fan gate, see page 6 and 11 Replace Clean or replace Adjust to between 10 - 14 bar Clean, tighten in place, or replace Increase Adjust head and fan gate, see page 6 and 11
	Dirty combustion head	70 - Nozzle or filter dirty 71 - Unsuitable nozzle delivery or angle 72 - Loose nozzle 73 - Impurities on flame stability spiral 74 - Erroneous head adjustment or not enough air 75 - Blast tube length unsuited to boiler	Replace See recommended nozzles, page 5 Tighten Clean Adjust, see page 11; open gate valve Contact boiler manufacturer
10 x blinks ● ● ● ● ● ● ● ● ● ●		76 - Connection or internal fault	

STATUS (optional)

Assembly

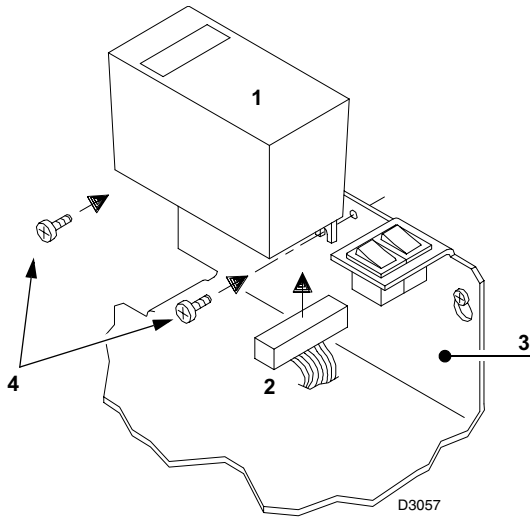

- 1 Status
- 2 Connector
- 3 Bracket of the burner
- 4 Fixing screws

D3057

A

B

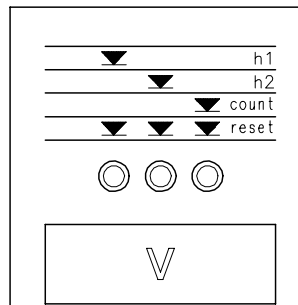
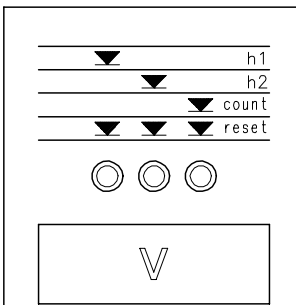

	POWER	(M)	Flame	Flame	Flame	Power	
1	●						0
2	●						0
3	●						S 1-2....
4	●					S....
5	●			●	●	S
6	●			●	●		
7	●					S
8	●						

	POWER	(M)	Flame	Flame	Flame	Power	
1	●						S
2	●			☀			S
3	●			☀			S

- ☀ = Led flashing
- = Led illuminated
- S = Time in seconds
- |||| = Burner start cycle terminated

(A)

STATUS

Accessory available on request.
See page 2.

ASSEMBLY

The burners are preset to accept the Status. To assemble, proceed as follows:

- Connect Status 1) using connector 2) fitted on the bracket 3).
- Fasten Status to the bracket using the screws 4) supplied with the kit.

The STATUS unit has three functions:

1 - BURNER OPERATING HOURS AND THE NUMBER OF FIRINGS ARE SHOWN ON DISPLAY V

Total operating hours

Press button "h1".

2nd stage operating hours

Press button "h2".

1st stage operating hours

Total hours - 2nd stage operating hours

Number of firings

Press button "count".

Resetting operating hours and number of firings

Press the three "reset" buttons simultaneously.

Non-volatile memory

The operating hours and the number of firings will remain in the memory even in the case of electrical power failures.

2 - INDICATES THE TIMES RELATIVE TO THE FIRING STAGE

The leds illuminate in the following sequence, see fig. A:

WITH CONTROL DEVICE TR CLOSED:

- 1 - Burner off, TL open
- 2 - Control device TL closed
- 3 - Motor start:

seconds count starts on read-out V

- 4 - 1st stage valve energized
- 5 - 2nd stage valve energized:

seconds count stops on read-out V

- 6 - 10 seconds after stage 5 the code |||| will appear on the read-out: this indicates that the starting phase is terminated.

WITH CONTROL DEVICE TR OPEN:

- 1 - Burner off, TL open
- 2 - Control device TL closed
- 3 - Motor start:

seconds count starts on read-out V

- 4 - 1st stage valve energized
- 7 - 30 seconds after stage 4:

seconds count stops on read-out V

- 8 - 10 seconds after stage 7 the code |||| will appear on the read-out: this indicates that the starting phase is terminated.

The times, in seconds, shown on read-out V, indicate the succession of the various starting stages described on page 12.

3 - IN THE CASE OF BURNER MALFUNCTIONS, THE STATUS PANEL INDICATES THE EXACT TIME AT WHICH THE FAULT OCCURRED.

There are 3 possible combinations of illuminated leds, see fig. (B).

For the causes of the malfunction refer to the numbers shown between brackets; see the legend on page 15 for interpretation of the numbers.

- 1 (9 ÷ 10)
- 2 (11 ÷ 29)
- 3 (32)

Key to symbols:

- **POWER** = Power present
- (M) = Fan motor blocked (red)
- ◀ = Burner lock-out (red)
- ◀ = Not used
- ◀ = 1st stage operation
- ◀ = Load level reached (Stand-by), led: on

D478