

Oil - kerosene burners

One stage operation

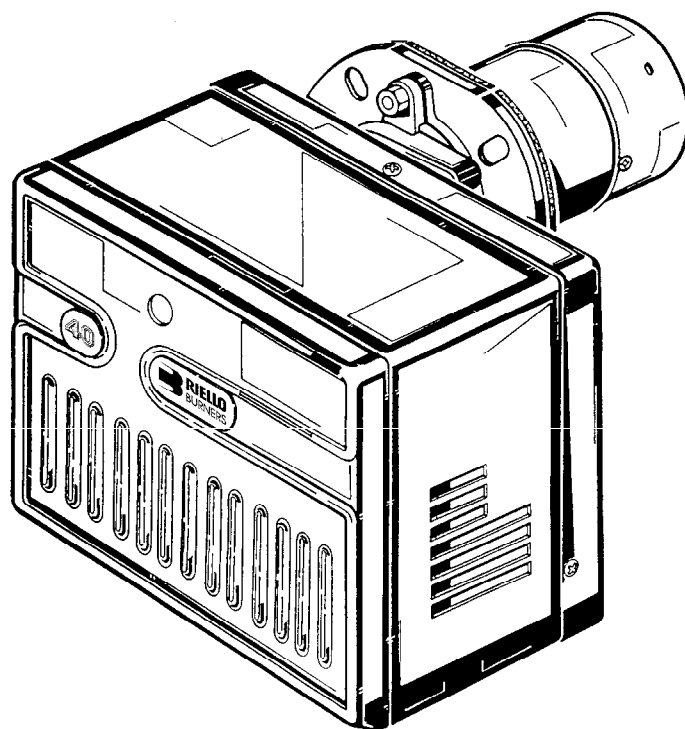

RIELLO 40

CODE	MODEL	TYPE
3746449	G10	464T50
3746457	G10	464T53

TECHNICAL FEATURES

Thermal power – output	54 – 120 kW – 4.5 – 10 kg/h
Fuel	Gas oil 35s, max. viscosity at 20 °C: 6 mm ² /s Kerosene 28s
Electrical supply	Single phase, 230V ± 10% ~ 50Hz
Motor	Run current 0.85A – 2800 rpm – 293 rad/s
Capacitor	4 µF
Ignition transformer	Secondary 8 kV – 16 mA
Pump	Maximum pressure 14 bar (203 psi)
Absorbed electrical power	0.18 kW

- Burner with CE marking in conformity with EEC directives: EMC89/336/EEC, Low Voltage 73/23/EEC, Machines 89/392/EEC and Efficiency 92/42/EEC
- The burner meets protection level of IP 40, EN 60529.

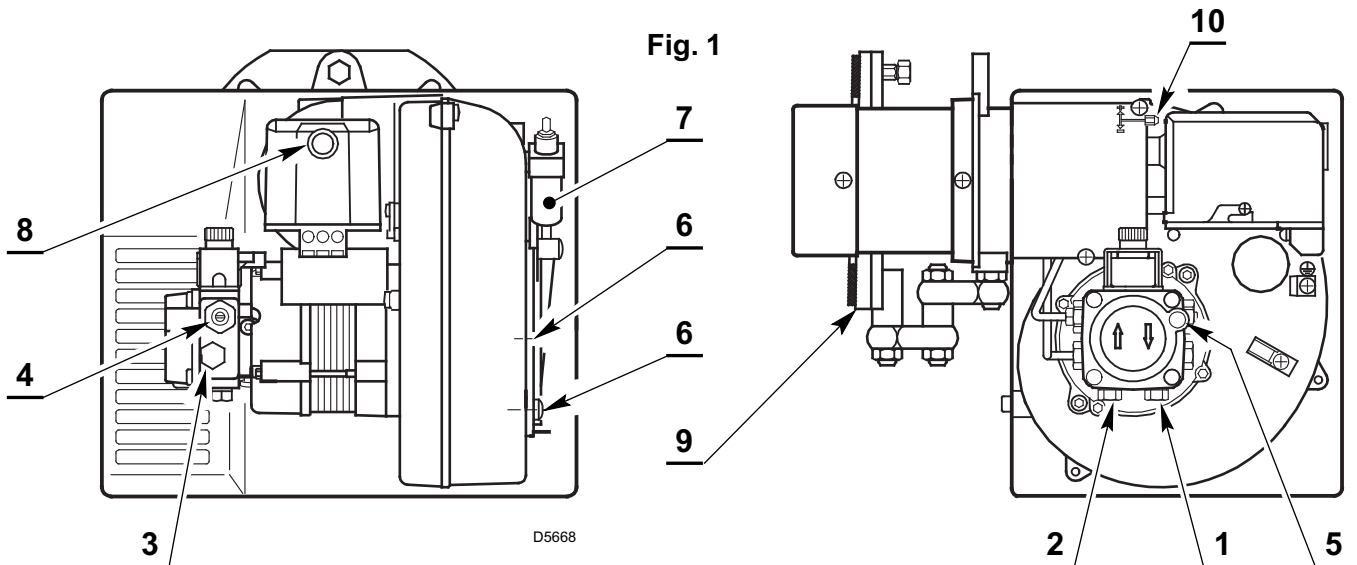

- 1 – Return line
- 2 – Suction line
- 3 – Gauge connection
- 4 – Pump pressure regulator
- 5 – Vacuum gauge connection
- 6 – Screws fixing air-damper
- 7 – Hydraulic jack with air-damper
- 8 – Lock-out lamp and reset button
- 9 – Flange with insulating gasket
- 10 – Combustion head adjustment screw

EQUIPMENT

Quantity	Description
1	Flexible pipe with nipple
1	Flange with insulating gasket
2	Screws and nuts for flange
1	Hinge
1	Screw of pump by-pass
1	Cable gland
1	Screw with two nuts for flange

WORKING RANGE

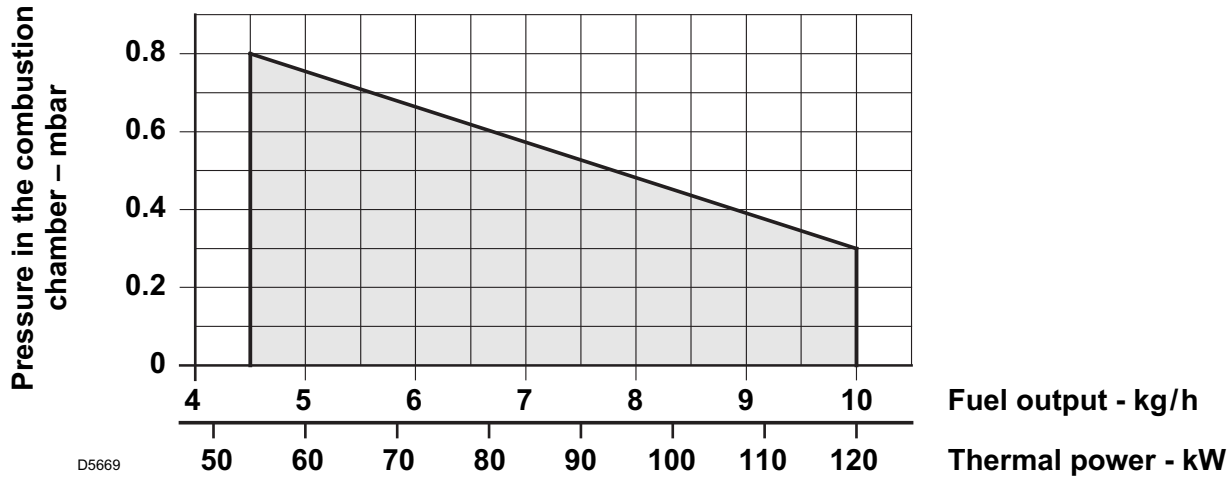

DIMENSIONS

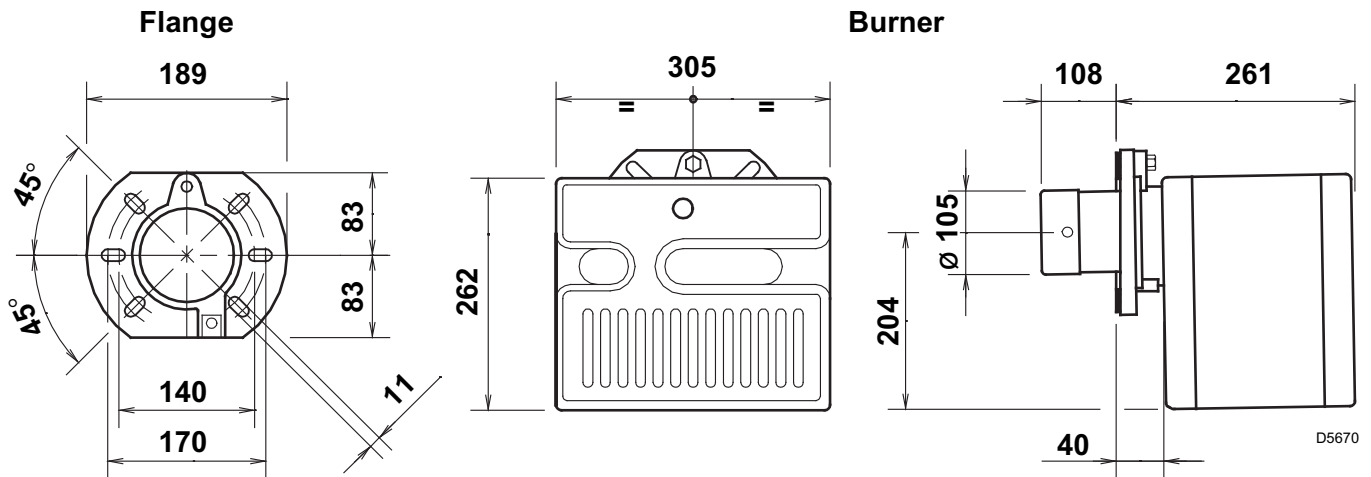

MOUNTING THE BURNER

It is necessary that the insulating gasket (9, fig. 1) is placed between the boiler door and the burner flange.

This insulating gasket has **six holes**, which, if necessary, can be modified as shown on the drawing on the right.

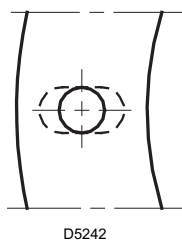

Verify that the installed burner is lightly leaned towards the button.
(See figure 2).

The burner is designed to allow entry of the flexible oil-lines on either side of the burner.

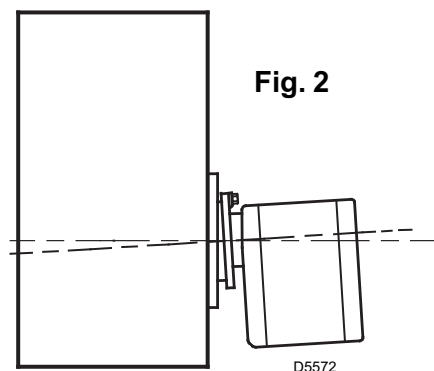

BURNER FIXING AND HINGE ASSEMBLY

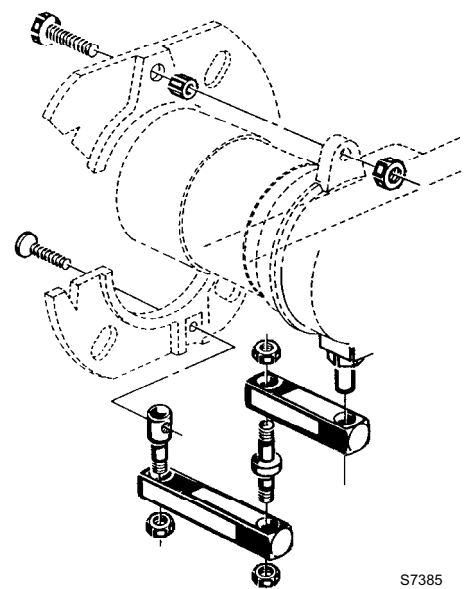

OIL LINES

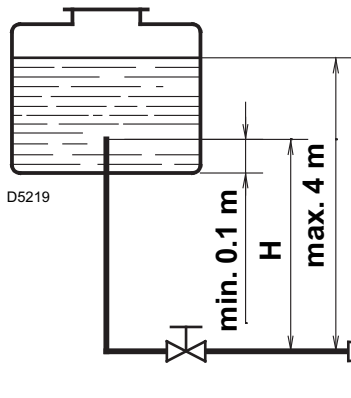

PRIMING THE PUMP

Loosen the plug of the vacuum gauge (5, fig. 1) and wait until the fuel flows out.

H meters	L meters	
	I. D. 8 mm	I. D. 10 mm
0.5	10	20
1	20	40
1.5	40	80
2	60	100

H = Difference of level.

L = Max. length of the suction line.

I.D. = Internal diameter of the oil pipes

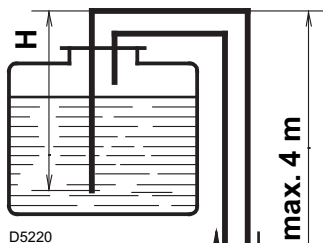

H meters	L meters	
	I. D. 8 mm	I. D. 10 mm
0	35	100
0.5	30	100
1	25	100
1.5	20	90
2	15	70
3	8	30
3.5	6	20

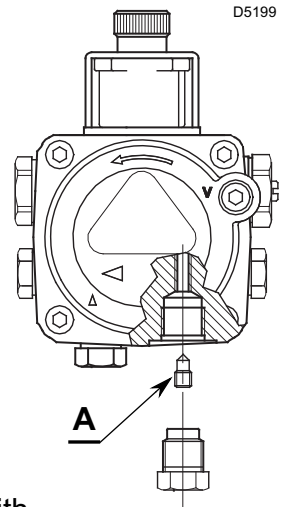

WARNING

The pump is supplied for use with a one pipe system. For use on a two pipe system, it is necessary to screw the **by-pass screw (A)** supplied as burner's accessory. (See figure).

The pump vacuum should not exceed a maximum of 0.4 bar (30 cm Hg). Beyond this limit gas is released from the oil.

Oil lines must be completely airtight.

The return line should terminate in the oil tank at the same level as the suction line; in this case a non-return valve is not required.

Should however the return line arrives over the fuel level, the non-return valve is indispensable.

This solution however is less safe than previous one, due to the possibility of leakage of the valve.

PRIMING THE PUMP:

Start the burner and wait for the priming. Should lock-out occur prior to the arrival of the fuel, await at least 20 seconds before repeating the operation.

Warning: before starting the burner make sure that the return pipe-line is not clogged: any obstruction would cause the pump seals to break.

WARNING:

- Check periodically the flexible pipes conditions. Using kerosene, they have to be replaced at least **every 2 years**.
- A metal bowl filter with replaceable micronic filter must be fitted in the oil supply pipe.

BURNER ELECTRICAL WIRING

230V ~ 50Hz

WARNING
Do not exchange the neutral with the phase.

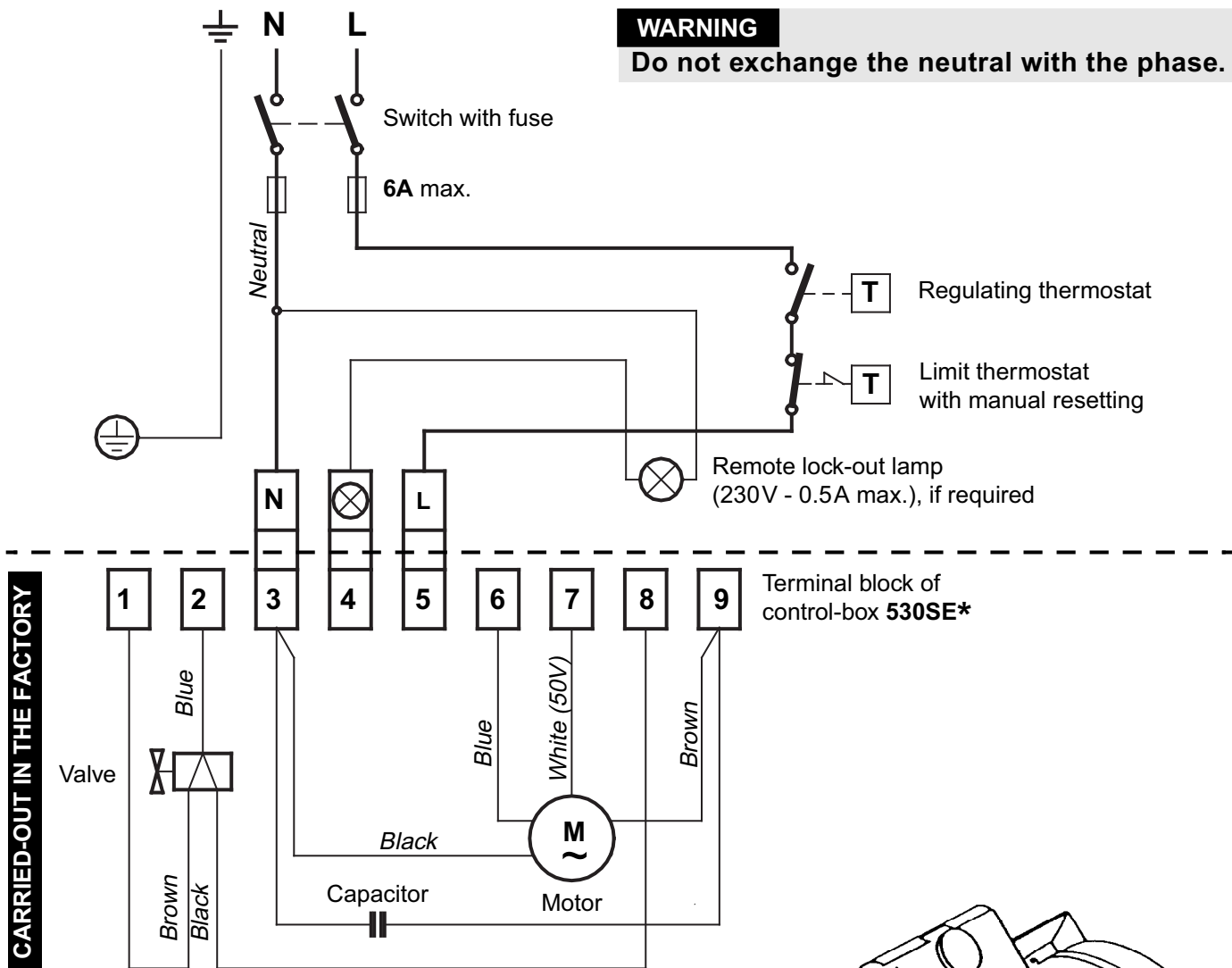

CARRIED-OUT IN THE FACTORY

D5228

NOTES

- Wires of 1 mm² section.
- The electrical wiring carried out by the installer must be in compliance with the rules in force in the Country.
- **To remove the control-box from the burner, loosen screw (A) (see figure) and pull towards the arrow.**
- The photoresistance is fitted directly into the control-box (underneath the ignition-transformer) on a plug-in support.

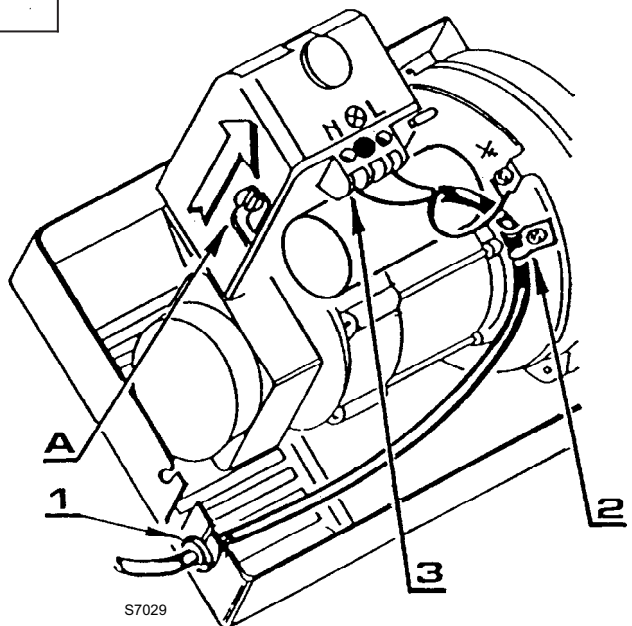

S7029

TESTING

Check the shut-down of the burner by opening the thermostats.

RUN OF THE ELECTRICAL CABLE

- | | |
|--------------------|------------------|
| 1 - Cable gland | N - Neutral |
| 2 - Cable clamp | L - Phase |
| 3 - Terminal block | ⏏ - Burner-earth |

COMBUSTION ADJUSTMENT **FUEL GAS OIL**

In conformity with Efficiency Directive 92/42/EEC the application of the burner on the boiler, adjustment and testing must be carried out observing the instruction manual of the boiler, including verification of the CO and CO₂ concentration in the flue gases, their temperatures and the average temperature of the water in the boiler.

To suit the required appliance output, fit the nozzle then adjust the pump pressure, the setting of the combustion head and the air damper opening in accordance with the following schedule.

Nozzle 1		Pump pressure 2	Burner output	Comb. head adjustment 3	Air damper adjustment 4
GPH	Angle	bar	kg/h \pm 4%	Set-point	Set-point
1.10	60°	12	4.72	2	3
1.25	60°	12	5.37	2.5	3.4
1.50	60°	12	6.44	3	3.8
1.75	60°	12	7.51	4	4
2.00	60°	12	8.59	5	5
2.25	60°	12	9.66	6	6

1 NOZZLES RECOMMENDED: Monarch type R
Delavan type W - B
Steinen type S - Q
Danfoss type S - B

2 PRESSURE: **8 bar :** the pump leaves the factory set at this value, which is suitable only for kerosene.

FOR GAS OIL INCREASE PRESSURE

12 bar : pressure suitable for gas oil in most cases.

14 bar : improves flame retention; it is therefore suitable for ignitions at low temperatures.

3 COMBUSTION HEAD SETTING: this is done when fitting the nozzle, with the blast tube removed. It depends on the output of the burner and is carried out by rotating the regulating rod, till the terminal plane of the blast tube is level with the set-point, as indicated in the schedule.

Terminal plane of the blast tube

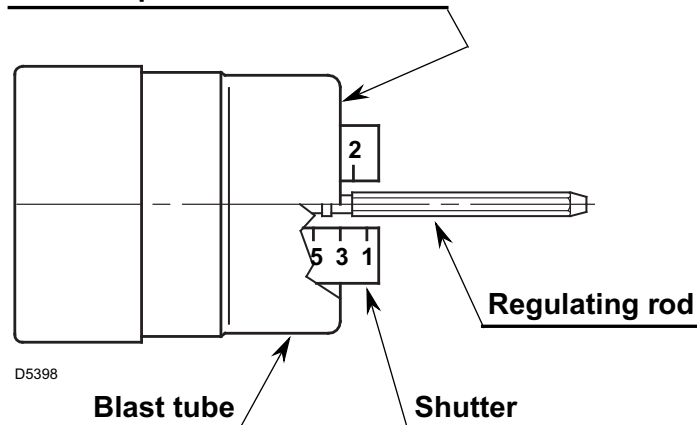

In the sketch on the left, the combustion head is set for an output of 1.50 GPH at 12 bar, while the shutter is level with set-point **3**, as required by the above schedule.

COMBUSTION ADJUSTMENT **FUEL KEROSENE**

In conformity with Efficiency Directive 92/42/EEC the application of the burner on the boiler, adjustment and testing must be carried out observing the instruction manual of the boiler, including verification of the CO and CO₂ concentration in the flue gases, their temperatures and the average temperature of the water in the boiler.

To suit the required appliance output, fit the nozzle then adjust the pump pressure, the setting of the combustion head and the air damper opening in accordance with the following schedule.

Nozzle 1		Pump pressure 2	Burner output	Comb. head adjustment 3	Air damper adjustment 4
GPH	Angle	bar	kg/h \pm 4%	Set-point	Set-point
1.50	60°	8	4.43	1.5	2.6
1.75	60°	8	5.17	2	2.9
2.00	60°	8	5.91	2.5	3.3
2.25	60°	8	6.64	3.5	3.5
2.50	60°	8	7.38	4	3.8
3.00	60°	8	8.86	5	5
3.00	60°	10	9.99	6	6

1 NOZZLES RECOMMENDED: Monarch type R
Delavan type B - W
Steinen type S - Q
Danfoss type S - B

For 2.50 - 3.00 GPH nozzles it is advisable to use, if possible, full cones.

2 PRESSURE: **8 bar :** the pump leaves the factory set at this value.
10 bar : maximum pressure for kerosene.

3 COMBUSTION HEAD SETTING: this is done when fitting the nozzle, with the blast tube removed. It depends on the output of the burner and is carried out by rotating the regulating rod, till the terminal plane of the blast tube is level with the set-point, as indicated in the schedule.

Terminal plane of the blast tube

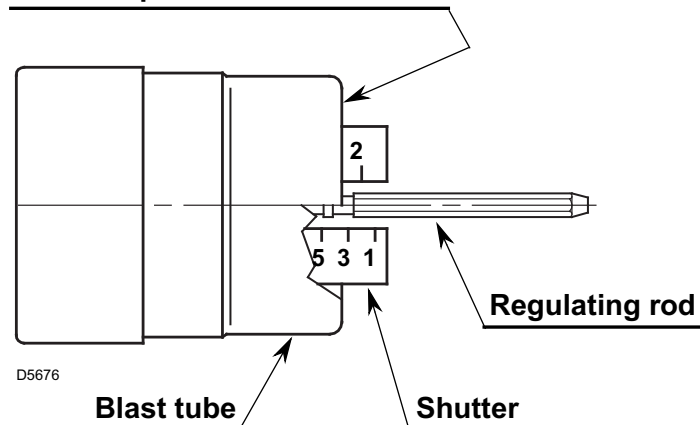

In the sketch on the left, the combustion head is set for an output of 2.25 GPH at 8 bar, while the shutter is level with set-point 3.5, as required by the above schedule.

Combustion head settings indicated in the schedule are valid for most cases.

The setting of the fan output according to the installation should normally be done only through the air damper. Should one subsequently want to retouch also the setting of the combustion head, with the burner running, operate on the rod **(1)** with a 6 mm spanner **(2)** as follows:

TURN TO THE RIGHT: (sign +)

In order to increase the volume of air entering the combustion chamber and thus diminishing its pressure.

There is a reduction of CO₂ and the adhesion of the flame to the air diffuser disc improves. *(Setting advisable for ignitions at low temperatures).*

TURN TO THE LEFT: (sign –)

In order to reduce the volume of air entering the combustion chamber and thus increasing its pressure. The CO₂ improves and the adhesion of the flame to the diffuser tends to reduce. *(This setting is not advisable for ignitions at low temperatures).*

In any case do not bring the combustion head setting more than one point away from that indicated in the schedule. One set-point corresponds to 3 turns of the rod; a hole **(3)** at its end facilitates counting the number of turns.

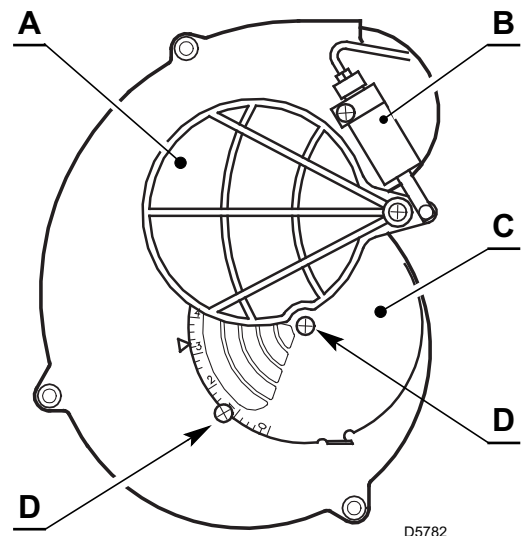
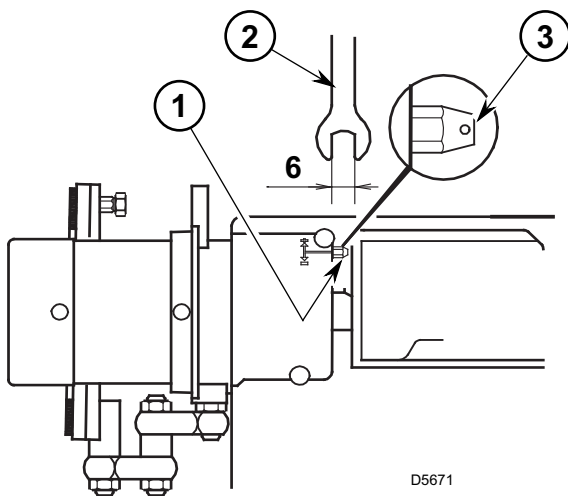

4 AIR DAMPER ADJUSTMENT:

The mobile air damper **(A)** operated by the jack **(B)** assures the complete opening of the air intake. The regulation of the air-rate is made by adjusting the fixed air damper **(C)**, after loosening the screws **(D)**. When the optimal regulation is reached, **screw tight the screws (D)** to assure a free movement of the mobile air damper **(A)**.

The settings indicated in the schedule refer to the burner with its metal cover fitted and the combustion chamber with “zero” depression.

These regulations are purely indicative.

Each installation however, has its own unpredictable working conditions: actual nozzle output; positive or negative pressure in the combustion-chamber, the need of excess air, etc. All these conditions may require a different air-damper setting.

It is important to take account of the fact that the air output of the fan differs according to whether the burner has its metal cover fitted or not.

Therefore we recommended to proceed as follows:

- adjust the air damper as indicated in the schedule (4);
- mount the cover, simply by means of the upper screw;
- check smoke number;
- should it become necessary to modify the air output, remove the cover by loosening the screw, adjust the air damper, remount the cover and finally recheck the smoke number.

NOTE: When the burner works at a firing rate higher than 9 kg/h remove the panel fitted inside the metal cover. (See figure).

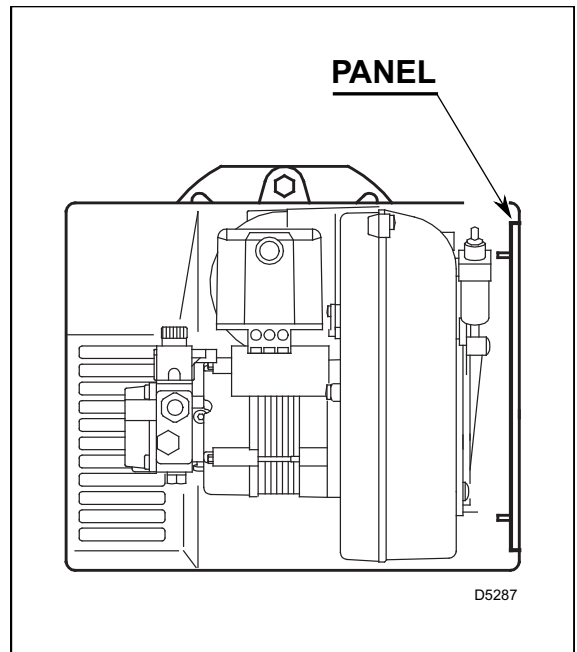

ELECTRODE SETTING

Attention:

Before assembling or removing the nozzle, loosen the screw (A) and move the electrodes ahead.

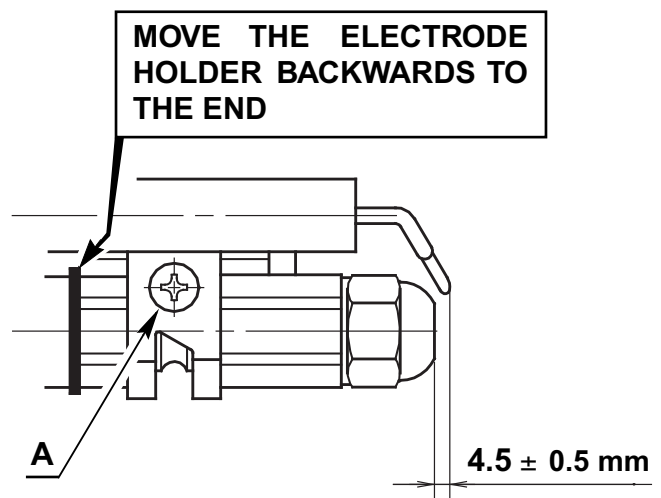
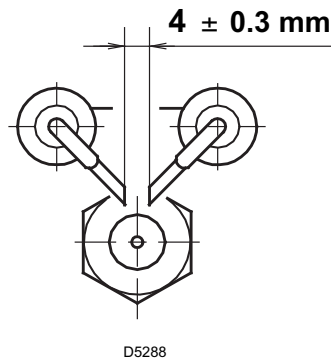

BURNER START-UP CYCLE

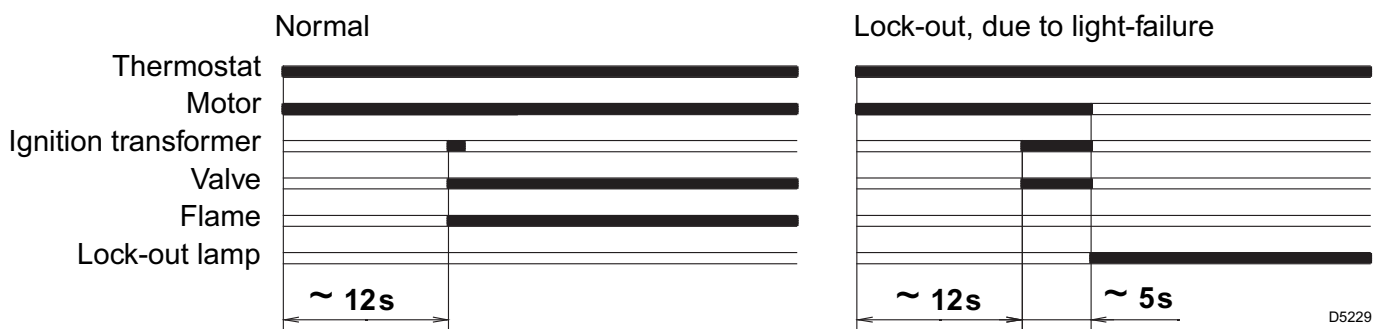

ONLY FOR GAS OIL

ADJUSTMENTS, TO AVOID FLAME - DETACHMENT, AT BURNER - IGNITION

This inconvenience can occur, when the temperature of the gas-oil decreases below + 5 °C.

1) CORRECT POSITIONING OF THE ELECTRODES

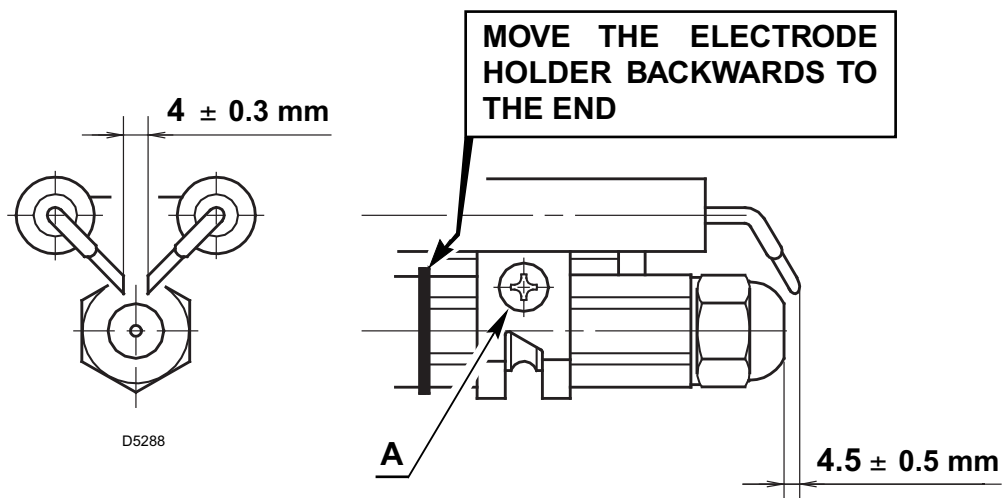

2) PUMP - SETTING

When the temperature of the gas-oil decreases below + 5 °C, increase the pressure to 14 bar.

3) COMBUSTION-HEAD SETTING

Regulate the combustion-head one set-point further ahead than indicated in the instructions.

Example: *the instructions require to set the combustion-head on set-point 3.*

Instead, the setting is made on set-point 4.

4) FAN - AIR DAMPER ADJUSTMENT

Adjust the air damper of the fan, such as to obtain a smoke-number not inferior to 1.
(i.e. a combustion with the lowest possible excess-air).