

Contents

Page	
4	Description
5	Specifications Dimensions
6	Installation Electrical Connections
7	User Keypad Programming Keypad
8	Overview Programming date and time
9	Basic and advanced operating modes Heating / Fan Only modes
10	Entering the switching program
11	Advanced operation Quick mode / temp offset
12	Menu options
14	Menu layout
16	Sensor wiring Connection diagrams
19	Fault Finding
22	Fault Finding Flow Chart
23	Notes

Installation and Users Instructions

Description

The MC100 is a high specification heating controller designed specifically to meet the demands of modern fuel efficient heating equipment and the latest environmental guidelines.

The MC100 uses optimum start technology as standard. It is continually monitoring the heating systems previous performance to determine the optimum time to turn the heating on to raise the building temperature to the required level when occupancy begins.

Optimum stop can also be selected which can save energy at the end of the heating period.

The MC100 has both a basic and advanced programming mode. The basic mode allows easy setting of the temperature and programs. In advanced mode different temperatures may be selected for different times of the day and temperatures may only be adjusted by +/- 3°C without the use of a password.

The MC100 is protected by 3 levels of password. The first will allow access to the day to day operation of the (ie. setting times and temperatures, the second allows access to parameters normally used only in the initial setting of the controller, and the third is only accessible to field service engineers for diagnostic purposes.

The 4 button user keypad allows easy selection of the heating and fan only modes, the override functions and fault reset. These may also be locked in various combinations to allow different levels of user accessibility.

The MC100 can give a readout of the hours the burner has operated, to help accessing servicing intervals and after being programmed with the correct data, can also give an indication of the running costs of the heating appliance

Specifications

General

Electricity supply
Internal Fuses

240V 50Hz Fused at 3A.
F1 20mm 6A 230V.
F2 20mm 500mA 230V.

Day set point range
Night set point range
Temperature accuracy
Overall switching differential
Sensing Element

0 - 34°C.
0 - 34°C.
0.5 °C.
Adjustable 0.5 - 3.0°C.
Internal or remotely mounted up to 100m from control.

Switching contacts ratings
Heating ON Indicator
Fault Indicator
Protection Rating

12A. 240V.ac. (resistive). All Volt Free
Red L.E.D.
Yellow L.E.D.
IP20

Time Switch

Display
Programming Instructions
Shortest switching time
Battery backup

2 line 5mm L.C.D.
3 per day
1 minute
50 hrs. after 100 hrs. connected to mains.

Dimensions

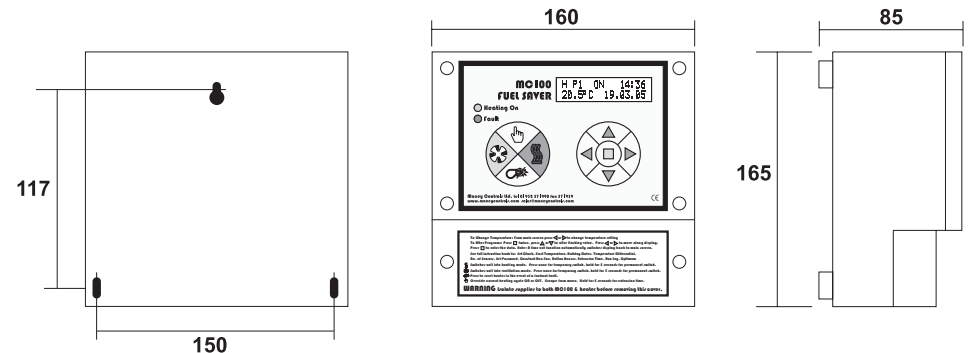

Installation

IMPORTANT

The MC100 or sensor **MUST NOT** be sited in areas of high electromagnetic fields, i.e. distribution boards, transformers or heavy duty supply cables.

MC100

Siting of the MC100 is important in that it must be fitted where the temperature will be generally representative of the area to be heated. It should be installed 1.7m above floor level and away from draughty areas or areas subjected to direct heat from sunlight, radiators etc. (Unless a remote sensor is being used)

Remote sensor (optional)

The siting of the MC100 should be no greater than 100m from the sensor and should be in a position easily accessible for programming and control. Siting of the sensor is important in that it must be fitted where the temperature will be generally representative of the area to be heated. It should be installed 1.7m above floor level and away from draughty areas or areas subjected to direct heat from sunlight, radiators etc.

Fixing

For fixing into wood use No.8 x 1¼" woodscrews, on masonry use screws together with wallplugs and on metal use M5 machine screws.

Remote sensor (optional)

Remove cover and offer the sensor up to the intended mounting position and mark two fixing holes. Fix sensor base plate to the wall.

See connection diagrams on page 16

MC100

Remove the two screws from the terminal cover and remove. Offer the unit up to the intended mounting position and mark the location of the three fixing holes using the template on the packaging box. Secure the top fixing leaving approximately 5mm protruding, hang the MC100 on the top fixing screw, line up the bottom fixing holes and secure using two screws.

Electrical Connections

IMPORTANT

Wiring external to the MC100 must be installed in accordance with I.E.E. Regulations together with any local regulations which may apply. Wiring should be completed in conduit, entry for which is provided in the bottom of the unit. See external wiring diagram. Mains supply and control circuit wiring should be completed in cables not less than 0.5mm² and fan circuit in not less than 1.5mm². The connection to the mains electrical supply can be taken from the appliance or a separate 'local' supply, but in both cases a local isolator must be fitted adjacent to the MC100. Should more than one appliance be controlled from one MC100 a relay box **MUST BE USED**.

WARNING - SENSOR WIRING

Sensor cable must be screened two core and a minimum of 0.6mm² if solid and 7 x 0.2mm² if multistrand. The screen must be grounded only at the MC100. Wiring for the temperature sensor **MUST BE RUN SEPARATELY** and apart from ALL other wiring. Failure to regard this instruction may cause the MC100 to malfunction and may render it faulty.

User keypad (4 Buttons)



A short press of either button will place the control into that respective mode until midnight of that day. (Indicated by a flashing H for heating or F for fan only, in the display)

Pressing either button for 5 secs. will permanently place the control into that respective mode. (Indicated by a 'steady' H for heating or F for fan only, in the display)



Resets the burner from lockout, (when this facility is available), and resets the run log to zero when used in the main menu.



Pressing once will activate the 'soft override' (will change the programs On or Off state until the next program step). Holding down for 5 secs will initiate or cancel the extension time. . Used as the 'escape key' in the programming menus.

Programming keypad (5 Buttons)



Use this button to enter data and move from a main screen to a sub-menu.

Holding down for 5 secs. will display the run log.

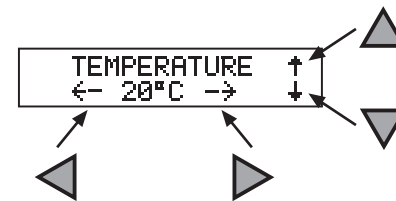

Use these two buttons to move up and down between screens.

Use these two buttons to increase/decrease the value.

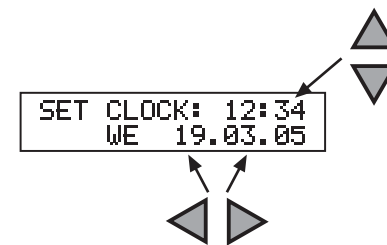

Use these two buttons to increase/decrease the selected value

Use these two buttons to move along the screen.

Overview

The MC100 comes preprogrammed with a typical heating program. After installation the minimum setup required will be to program the current time and date.

Power up



On initial power up a blank display followed by a partial display will appear for up to 15 seconds before the full display.

Programming the date and time if not correctly displayed

Note: GMT and BST will automatically be set and will change automatically twice each year.

H ON 14:36
20.5°C 19.03.05

From the main screen press



to enter the password screen

ENTER PASSWORD
0000

From the password screen press



to enter the main menu

Note: the password screen does not appear if set to the factory default 0000

PROGRAM TIMES ↓

From the program times screen press



once to enter the set clock screen

SET CLOCK ↑ ↓

From the set clock screen press



to enter the setting screen

SET CLOCK: 00:00
WE 01.01.03

Press

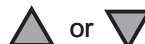

to adjust the hour

SET CLOCK: 00:00
WE 01.01.03

Press



to move to minutes

SET CLOCK: 00:00
WE 01.01.03

Press

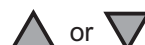

to adjust the minutes

Set date . month . year in a similar way. Note: day will be automatically set

SET CLOCK: 00:00
WE 01.01.03

Press



to enter the data and return to the set clock screen

SET CLOCK ↑ ↓

Press

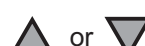

to move to another screen

Alternatively press  or wait 30secs to return to main screen

Basic & advanced operating modes

The MC100 is supplied in the BASIC operating mode: This allows easy adjustment of the temperature set point and allows entering 1 switching programs per day.

By selecting the ADVANCED operating mode, easy temperature set point adjustment is limited to +/- 3°C (in the temp offset screen) without the use of a password.

The ADVANCED mode programs allow up to 3 switching programs per day each with a different temperature set point if required.

Selecting operating mode

H ON 14:36
20.5°C 19.03.05

From the main screen press



to enter the password screen

ENTER PASSWORD
0000

From the password screen press



to enter the main menu

Note: the password screen does not appear if set to the factory default 0000

PROGRAM TIMES ↓

From the program times screen press



6 times to enter the extended menu screen

EXTENDED MENU ↑

From the extended menu screen press



to enter the password screen

ENTER PASSWORD
0000

From the password screen press



to enter the extended menu

Note: the password screen does not appear if set to the factory default 0000

OPERATION
←- BASIC -> ↓

Press



to select basic or advanced

OPERATION
←- BASIC -> ↓

Press



to move to another screen

Alternatively press  to enter selection

Heating / Fan Only modes





A short press of either button will place the control into that respective mode for the remainder of the day. (Indicated by a flashing H for heating or F for fan only, in the display) Pressing either button for 5 secs. will permanently place the control into that respective mode. (Indicated by a 'steady' H for heating or F for fan only, in the display)

Entering the switching program (BASIC OPERATION)

Individual days may be programmed with one program and a Monday to Friday block may also be set.

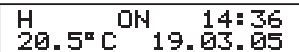
Note: A basic program of Monday to Friday on at 08:00 (8am) and off at 17:00 (5pm) and a set point temperature of 20°C is preprogrammed into the MC100.

 From the main screen press to enter the password screen

 From the password screen press to enter the main menu

Note: the password screen does not appear if set to the factory default

 From the program screen press to enter the setting screen

 Press  or  to alter the day (individual days are selectable together with MO-FR as one entry)

 Press  to move to 'ON hour'

 Press  or  to change the 'ON hour'

 Press  to move to 'ON minutes'

Set ON minutes and OFF time in a similar way

 Press  to select the day again. Work through subsequent days and program no's. as required



 Press to enter the program



 Press  or  to move to another screen

Alternatively press  or wait 30secs to return to main screen

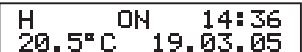
Temperature adjustment (BASIC OPERATION)

The set point temperature is carried out without entering a password

 during normal operation press  or  to enter the temperature screen

 Press  or  to adjust the temperature

Press to enter selection



Important: As the MC100 is an optimum start controller the program start time should be when occupancy begins and no pre-heat time should be allowed for.

Entering the switching program (ADVANCED OPERATION)

The ADVANCED programming is similar to BASIC operation with the addition of:

 selects the temperature for the program entry

 selects up to 3 programs per day

 select  to temporarily disable the program entry

Sample program

The screens pictured below show the settings required in the ADVANCED operation for the following program:

Monday to Friday on between 8am and 1pm controlled at 20°C
Monday to Friday on between 2pm and 5pm controlled at 20°C
Saturday on between 8.30am and 12pm controlled at 18°C

 1. Set MO-FR Program 1: Temp 20°C: On 08:00 Off 13:00
Sets these times for Monday through to Friday



 2. Set MO-FR Program 2: Temp 20°C: On 14:00 Off 17:00
Sets these times for Monday through to Friday

 3. Set SA Program 1: Temp 18°C: On 08:30 Off 12.30
Sets these times and temperature for Saturday

Temp offset (ADVANCED OPERATION)

Temp offset allows the adjustment of the set point temperature to be carried out without entering a password, allowing a limited day to day adjustment of +/- 3°C.

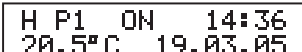
ie. If the temperature has been set to 20°C in the program and the temp offset is set to +2°C then the set point will have been adjusted to 22°C (20+2=22)

 during normal operation press  or  to enter the temp offset screen

 Press  or  to adjust the temperature by +/- 3°C

Press to enter selection

Menu options

Run Mode

RUN MODE
ON ← -> OFF ↓

Turns the controller On or OFF.

Set Temperature

TEMPERATURE ↑
←- 20°C -> ↓

Adjusts the set point temperature.

Frost Temperature

FROST TEMP ↑
←- 02°C -> ↓

Sets temperature that heater operates during fan only, heating off times and holiday periods. May be turned OFF

Holiday Dates

HOLIDAY DATES:
01.01 -> 01.01

Suspends the program while the buiding is unoccupied. Enter first day of holiday and day of return.

New Password

NEW PASSWORD:
0000

Sets a new password.

Temperature Differential

DIFFERENTIAL ↑
←- 1.0°C -> ↓

Sets the switching differential for all set points.

Night Temperature

NIGHT TEMP ↑
←- OFF -> ↓

Sets temperature that heater operates during program OFF times. May be turned OFF

No. of Sensors

No OF SENSORS ↑
←- 1 -> ↓

Sets the number of sensors connected.

Extension Time

EXTENSION TIME ↑
←- 1hour -> ↓

Extends the current program when is pressed for 5 secs. 

Button Access

BUTTON ACCESS ↑
←-ALL ACTIVE-> ↓

Sets the level of user button access.

Constant Run Fan

CONSTANT FAN ↑
←- OFF -> ↓

Heater fan runs constantly during program times in heating mode.

Optimum Stop

OPTIMUM STOP ↑
←- 0°C -> ↓

Sets the temperature differential for optimum stop to begin.

Optimum stop:

Set temperature differential (preprogrammed to 0°C).

Optimum stop will switch off the heating to save energy before the end of the program time.

Example: If the heating program calls for the building to be heated to 20°C, but it is felt that at the end of the heating program this temperature could drop to 18°C with no detrimental effect, then the optimum stop should be set to 2°C (20°C - 18°C). This 2°C will be applied to any of the programs in use.

Note: A setting of 0°C effectively turns optimum stop off.

High / Low Differential

HI/LOW DIFF ↑
←- 3°C -> ↓

Sets the temperature differential for hi / low operation. Note: Hi / low only available with add on module.

Run Log

HOURS: 00000:00
COST £0.00

Displays burner hours run and approximate running cost.

Note: Run log may also be displayed from the main display py pressing and holding  for 10 secs. (Password not required)

Power and Cost

POWER: 0000kW
COST: 0.000P/kWh

Enters data to calculate approximate running cost.

Service Date

SERVICE 01.06.03
ON 01460_256404

Displays service reminder and contact phone No.

Engineer Menu

ENGINEER ↑
MENU ↓

Menu only available to Powrmatic service engineers.

Menu Layout

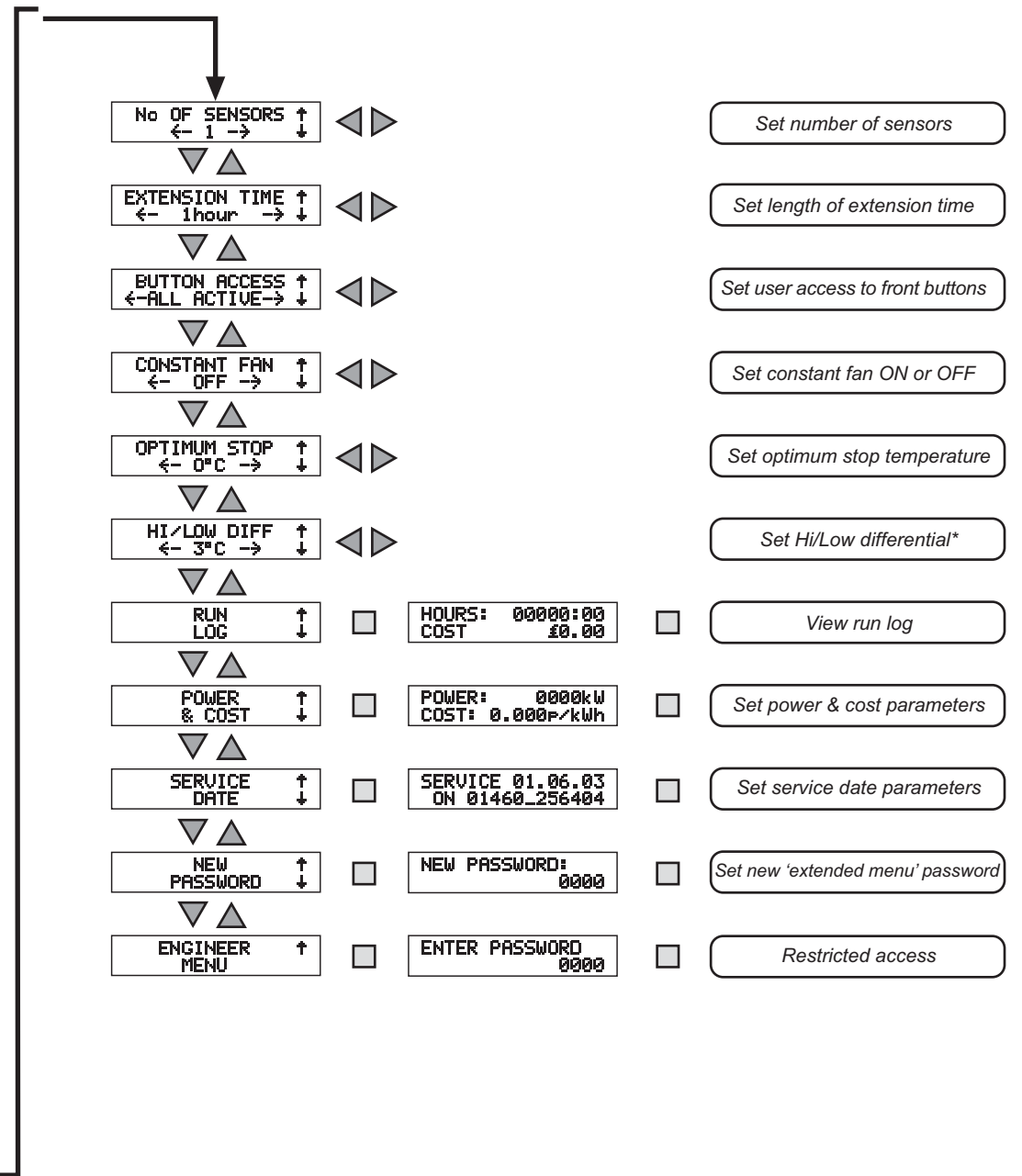
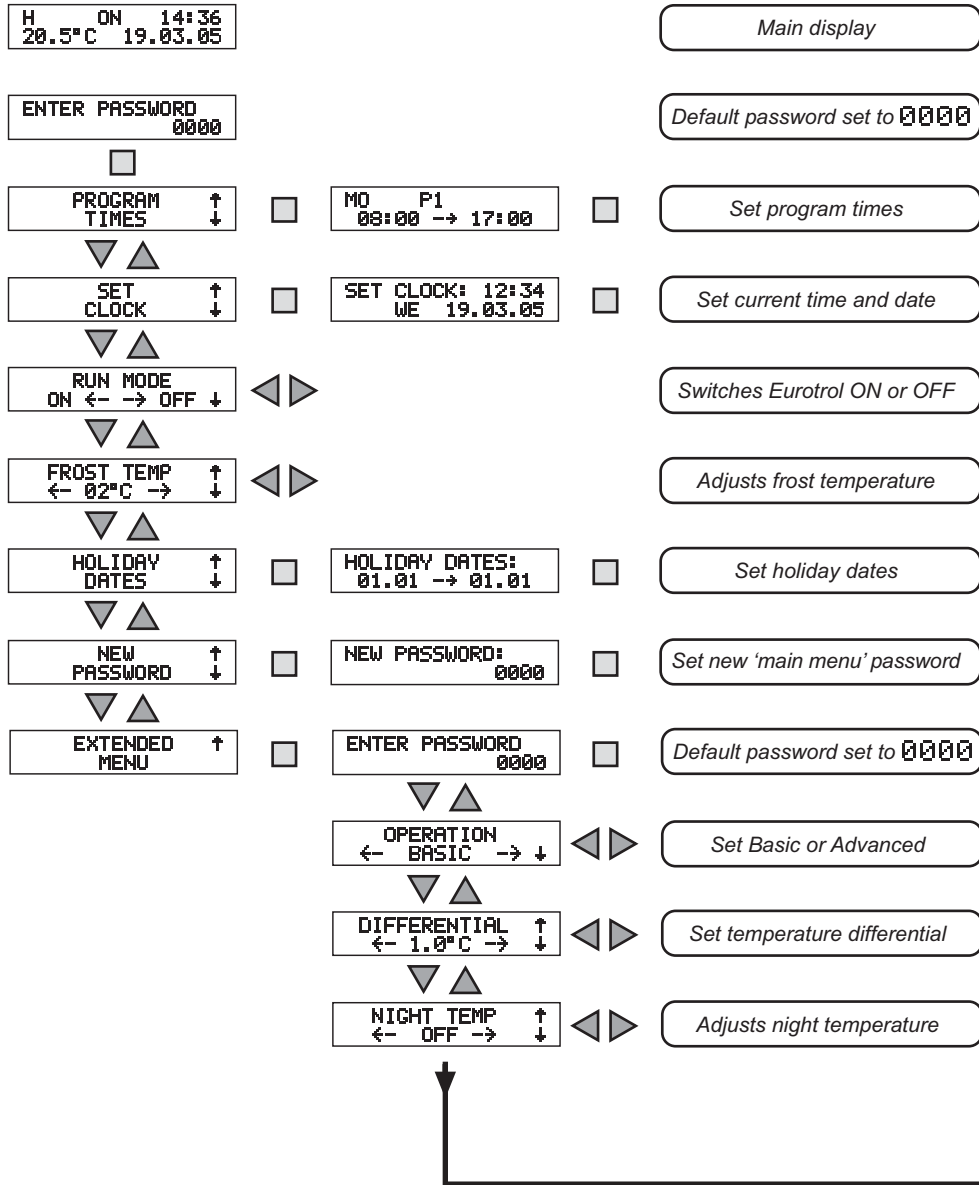

*When applicable

Sensor Wiring

A single remote sensor may be used in place of the standard internal sensor.

Two remote sensors may be used which relay an average of the two temperatures back to the MC100

Important

Sensor cable must be screened two core and a minimum of 0.6mm² if solid and 7 x 0.2mm² if multistrand. The screen must be grounded only at the MC100. Wiring for the temperature sensor **MUST BE RUN SEPARATELY** and apart from ALL other wiring. Failure to regard this instruction may cause the MC100 to malfunction and may render it faulty.

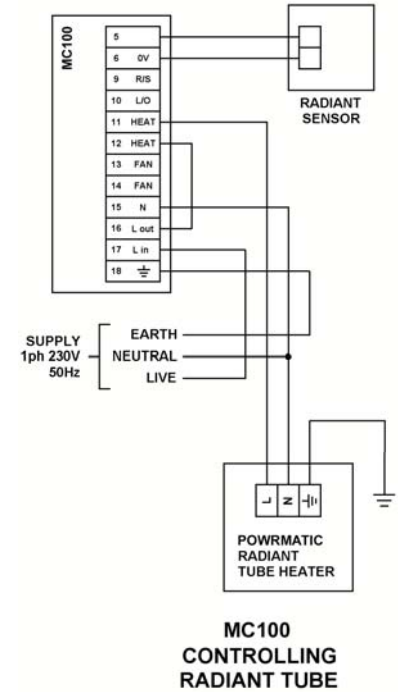
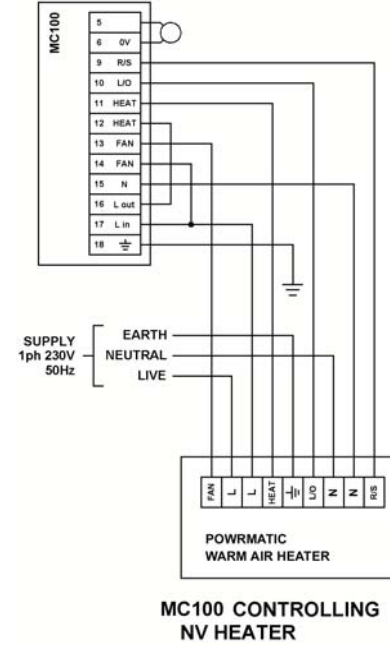
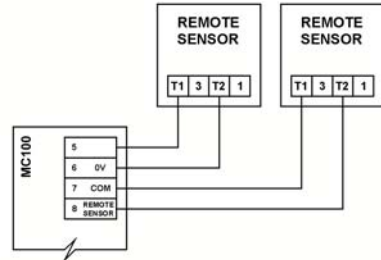
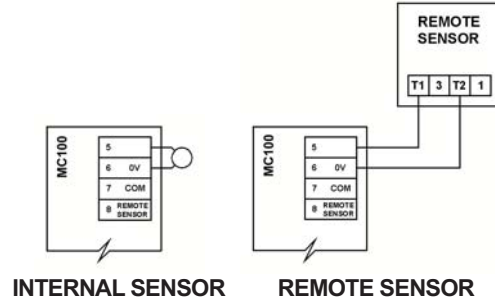

Connection Diagrams

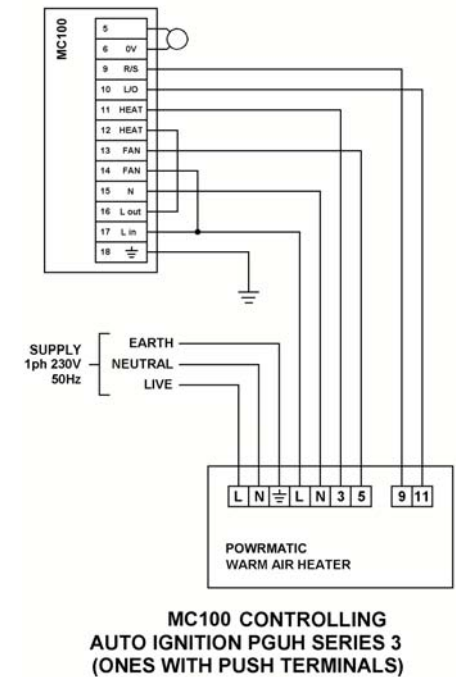
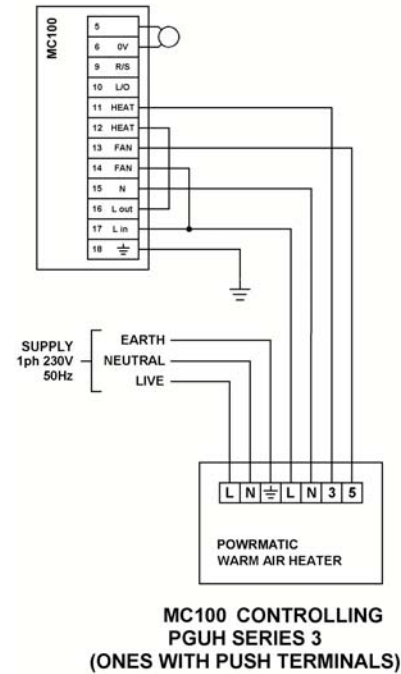
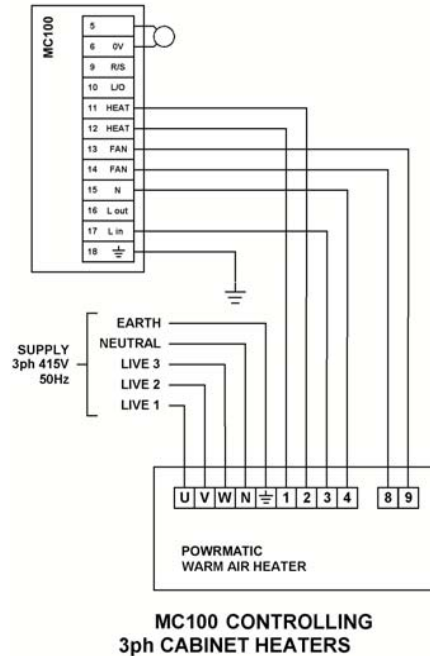
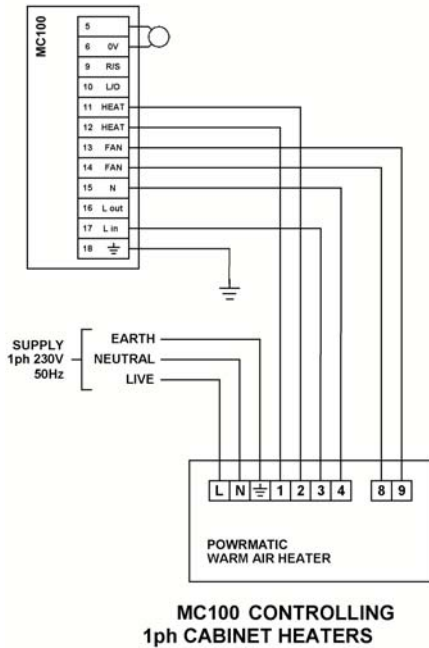

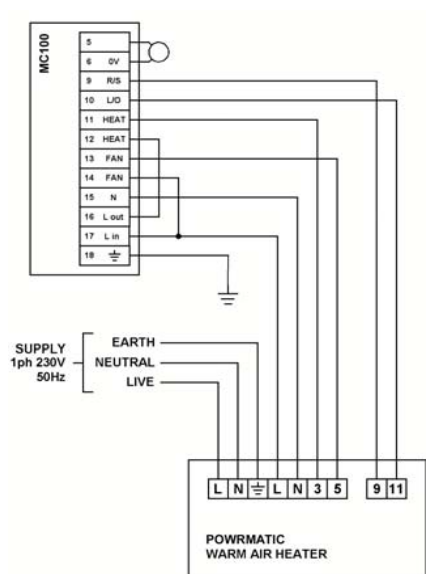

MC100 CONTROLLING EUROMATIC (ONES WITH PUSH TERMINALS)

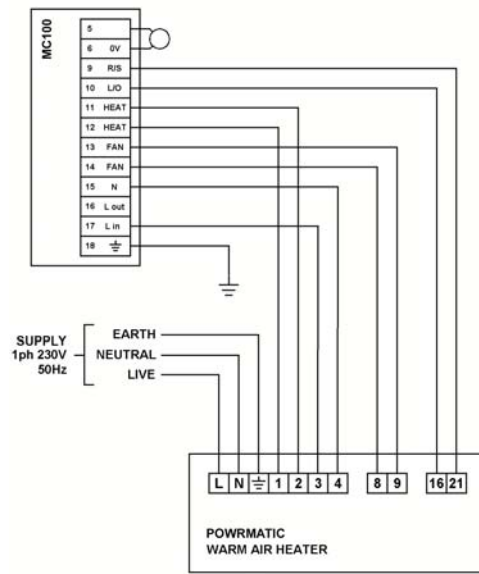

MC100 CONTROLLING 'OLD STYLE' EUROMATIC (ONES WITH SCREW TERMINALS)

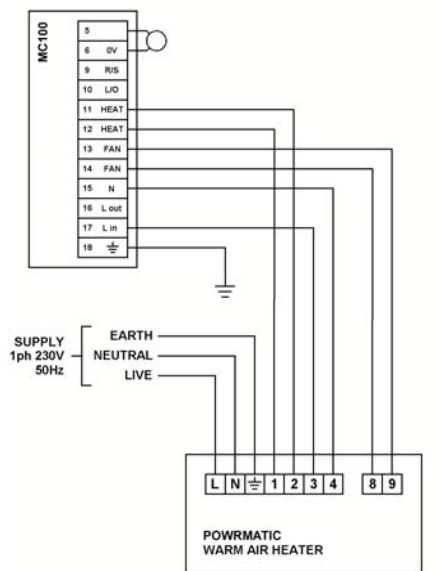

MC100 CONTROLLING 'OLD STYLE' PGUH PERMANENT PILOT (ONES WITH SCREW TERMINALS)

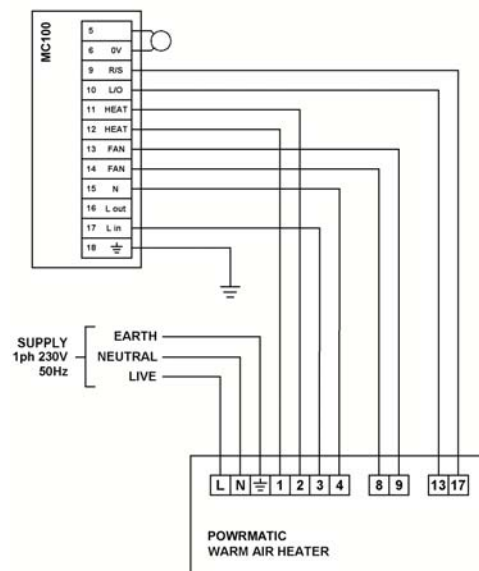

MC100 2 CONTROLLING 'OLD STYLE' PGUH AUTO IGNITION (ONES WITH SCREW TERMINALS)

Fault Finding

If the heating doesn't come on when expected



Follow this checklist to ensure correct operation. The heating should be on when the red LED is lit on the front panel. This assumes the controller is in the basic mode of operation (set in the extended menu).

- 1) Set the Run Mode to ON. Press to enter the menu and press to the run mode screen. If the 'ON' is not flashing, press the or button until it is, and then press .
 - 2) Set the controller to heating. Hold down the button for over 5 seconds. There should now be a letter 'H' in the top left corner of the display.
 - 3) Check the time & date settings are correct. The clock is in 24 hour format. When setting the date, the day of the week is also shown. Use this to double-check the correct date.
 - 4) Set the control temperature to the maximum so the heater will come on. Press the or button from the standard display screen to show the current temperature setting. Hold down the button to increase the temperature and press when it reads 34C.
 - 5) Make sure there is a program running. Press twice to enter the PROGRAM TIMES screen. Press or to change to the current day of the week that the clock is set for. Check that the current time on the clock is between the on and off times for this day. Make sure the off time is not set to 00:00 as this effectively turns the program off.
- At this point the main display screen should show "H ON" in the top left corner of the LCD and the heating should be on.
- 6) Override. Pressing the button should toggle the heating on and off.
 - 7) Holiday period. If the current date falls within the programmed holiday period the controller will not heat. This will be indicated on the standard display screen with 'H HOL OFF'. Check holiday date settings.
 - 8) Optimum stop. This feature can turn the heating off towards the end of a program. The default setting for optimum stop is off (0C). Check this setting in the Extended Menu.

If all these settings are correct and the red 'Heating on' LED doesn't light there may be a fault with the controller. If the LED is lit but the heater does not operate, there is possibly a fault with the heater itself or the wiring.

If the fan doesn't come on when expected

In fan mode the fan will operate throughout each program independent of temperature. Complete the steps above with the exception of steps 4 & 8 as these have no effect in fan mode.

For step 2, hold down the  button instead of . The display should indicate 'F' instead of 'H'.



There is no LED to indicate the fan is running so if these steps fail then there could be a problem with the fan itself or a wiring fault.

If you want the fan to run as well as the heating during the programmed times then you need to set the 'Constant Run Fan' option to on in the extended menu.

If the heating comes on when not expected

1) Check the time & date settings are correct. The clock is in 24 hour format. When setting the date, the day of the week is also shown. Use this to double-check the correct date.

2) Make sure there is not a program running. Press  twice to enter the PROGRAM TIMES screen.

Press  or  to change to the current day of the week that the clock is set for. Check that the current time on the clock is not between the on and off times for this day. You could set the off time to 00:00 as this effectively turns the program off.

3) Check the Frost Temp (main menu) and Night Temp (extended menu) settings. If either of these are set above the ambient temperature the heating could come on. The Frost Temp will be active when the run mode is OFF, or during the holiday period. The Night Temp will be active when not in a program.

4) Optimum start. This is a feature designed to bring on the heating before the program is due to start so that the correct temperature is achieved at the time the program starts. This can look like the heating has come on incorrectly which is not the case.

If the heating comes on when the red LED on the front panel is not lit then there is probably a wiring fault.

If the display flashes every second, or goes blank

This usually occurs when the controller is first installed and powered up, or if power has been removed for a long period of time. The display will 'blink' every second, or it could go completely blank for a short time. This is a result of the back-up battery being very low on charge. The problem will correct itself if the unit is left powered up. This could take from between 5 and 30 minutes.

If you suspect a wiring fault

If the red heating LED lights but the heater doesn't begin to run, or the fan doesn't run when it should follow the steps below.

- 1) Remove all connections to the heat relay on the terminal block (TB 11&12). Test for continuity between the two terminals when the heater should be on. If not the controller may be faulty. Check the fan relay in the same way (TB 13&14).
- 2) Ensure that mains live, neutral and earth are connected correctly in the terminal block.
- 3) With the power switched off, use a multi-meter to test for continuity between Live In (TB 17) and Live Out (TB 16). These are connected via a 6.3 Amp fuse. If there is no connection between the two, the fuse may need replacing.
- 4) Check that the unit is wired in accordance with the diagrams on pages 16 - 18.

Fault Finding Flow Chart

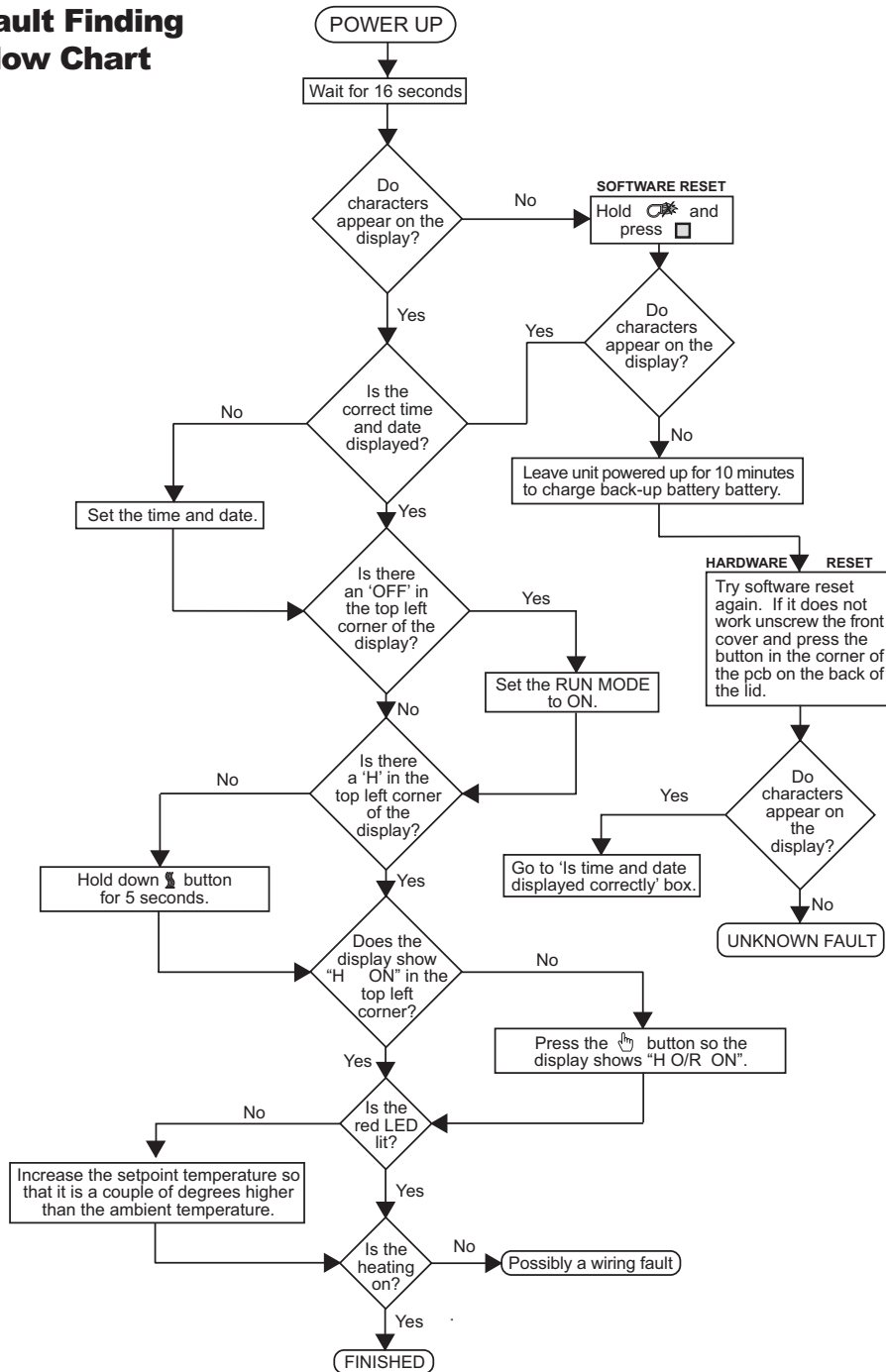

Crystal Haven House, Hanworth Lane, Chertsey, Surrey, KT16 9JX

TEL: +44 (0) 1932 571990

FAX: +44 (0) 1932 571939

E-mail: sales@maceycontrols.com

Web: maceycontrols.com

Produced by Macey Controls Ltd

Every effort is made to ensure accuracy at time of going to press. However the company reserves the right to alter specifications without prior notice.