

Installation & Servicing Instructions

Promax HE Store Range

Condensing Boilers with
Integrated Hot Water
Storage

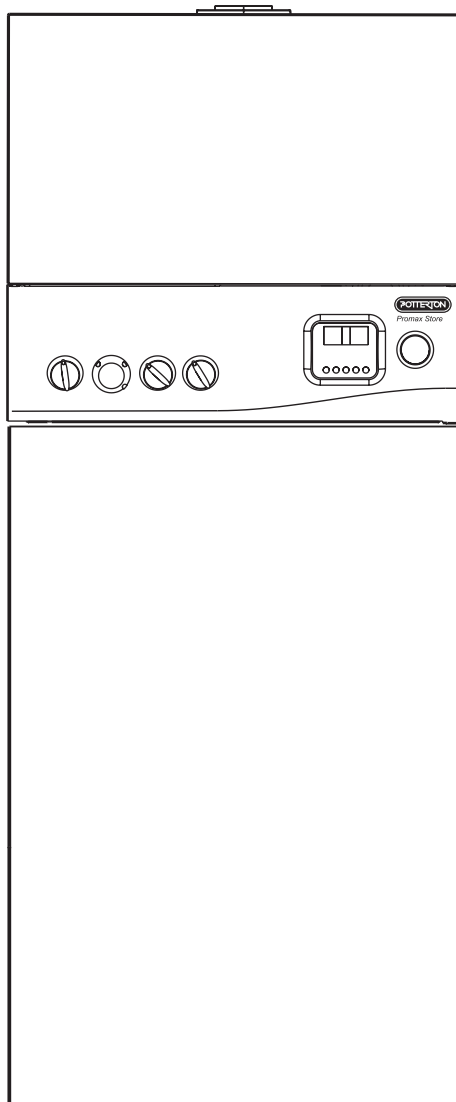

Please keep these instructions in a safe place.
If you move house, please hand them over to the next occupier

Natural Gas

Potterton HE Store

G.C.N° 41 601 24 (90 litre)

G.C.N° 41 591 76 (115 litre)

G.C.N° 41 591 77 (150 litre)

About the Boiler

See page 4 for models covered by these instructions.

This is a Floor Mounted Fan Assisted Balanced Flue Gas Boiler.

This boiler is for use with Natural Gas (G20) only at 20 mbar and for use in GB/IE only.

About Safety

The Gas Safety (Installation and Use) Regulations.

“ In your own interest, and that of safety, it is law that all gas appliances are installed by competent persons, in accordance with the above regulations. Failure to install appliances correctly could lead to prosecution.”

Installation must be in accordance with the Installation & Service Instructions and the rules in force.

**Read these Instructions before installing or lighting the boiler
These Instructions include the Benchmark Commissioning Checklist
and should be left with the user for safe keeping.**

The Benchmark Scheme

Benchmark places responsibilities on both manufacturers and installers. The purpose is to ensure that customers are provided with the correct equipment for their needs, that it is installed, commissioned and serviced in accordance with the manufacturer's instructions by competent persons and that it meets the requirements of the appropriate Building Regulations. The Benchmark Checklist can be used to demonstrate compliance with Building Regulations and should be provided to the customer for future reference.

Installers are required to carry out installation, commissioning and servicing work in accordance with the Benchmark Code of Practice which is available from the Heating and Hotwater Industry Council who manage and promote the Scheme. Visit www.centralheating.co.uk for more information.

© Baxi Heating UK Ltd 2009 All rights reserved. No part of this publication may be reproduced or transmitted in any form or by any means, or stored in any retrieval system of any nature (including in any database), in each case whether electronic, mechanical, recording or otherwise, without the prior written permission of the copyright owner, except for permitted fair dealing under Copyrights, Designs and Patents Act 1988.

Applications for the copyright owner's permission to reproduce or make other use of any part of this publication should be made, giving details of the proposed use, to the following address:

The Company Secretary, Baxi Heating UK Ltd, The Wyvern Business Park, Stanier Way, Derby, DE21 6BF.

Full acknowledgement of author and source must be given.

WARNING: Any person who does any unauthorised act in relation to a copyright work may be liable to criminal prosecution and civil claims for damages.

Building Regulations and the Benchmark Commissioning Checklist

Building Regulations (England & Wales) require notification of the installation of a heating appliance to the relevant Local Authority Building Control Department. From 1 April 2005 this can be achieved via a Competent Persons Self Certification Scheme as an option to notifying the Local Authority directly.

In England and Wales the electrical installation of an Ecogen appliance is notifiable under the current Part P building regulations.

In Scotland the electrical Installation of an Ecogen appliance requires a building warrant (legal permission from the local authority to start the work). This building warrant has to be approved by a registered electrical installer (known formally as an 'approved certifier') or be checked by the local authority.

In Northern Ireland guidance should be taken from the local authority or equivalent governing body for all electrical works.

The Health & Safety Executive operates the 'Gas Safe Register', a self-certification scheme for gas heating appliances.

These arrangements represent a change from the situation whereby compliance with Building Regulations was accepted as being demonstrated by completion of the Benchmark Logbook (which was then left on site with the customer).

With the introduction of Self Certification Schemes, the Benchmark Logbook is being withdrawn. However, a similar document in the form of a commissioning checklist and service interval record is incorporated at the back of these instructions.

This company is a member of the Benchmark initiative and fully supports the aims of the programme. Its aim is to improve the standards of installation and commissioning of central heating systems in the UK and to encourage the regular servicing of all central heating systems to ensure safety and efficiency.

Building Regulations require that installations should comply with manufacturer's instructions. It is therefore important that the commissioning checklist is completed by the installer. The relevant section of Building Regulations only relates to dwellings. Therefore the checklist only applies if the appliance is being installed in a dwelling or some related structure.

The flowchart opposite gives guidance for installers on the process necessary to ensure compliance with Building Regulations.



This product has an energy rating (A) on a scale of A to G.
For more information see www.boilers.org.uk. This is a certification mark.

Installer Notification Guidelines

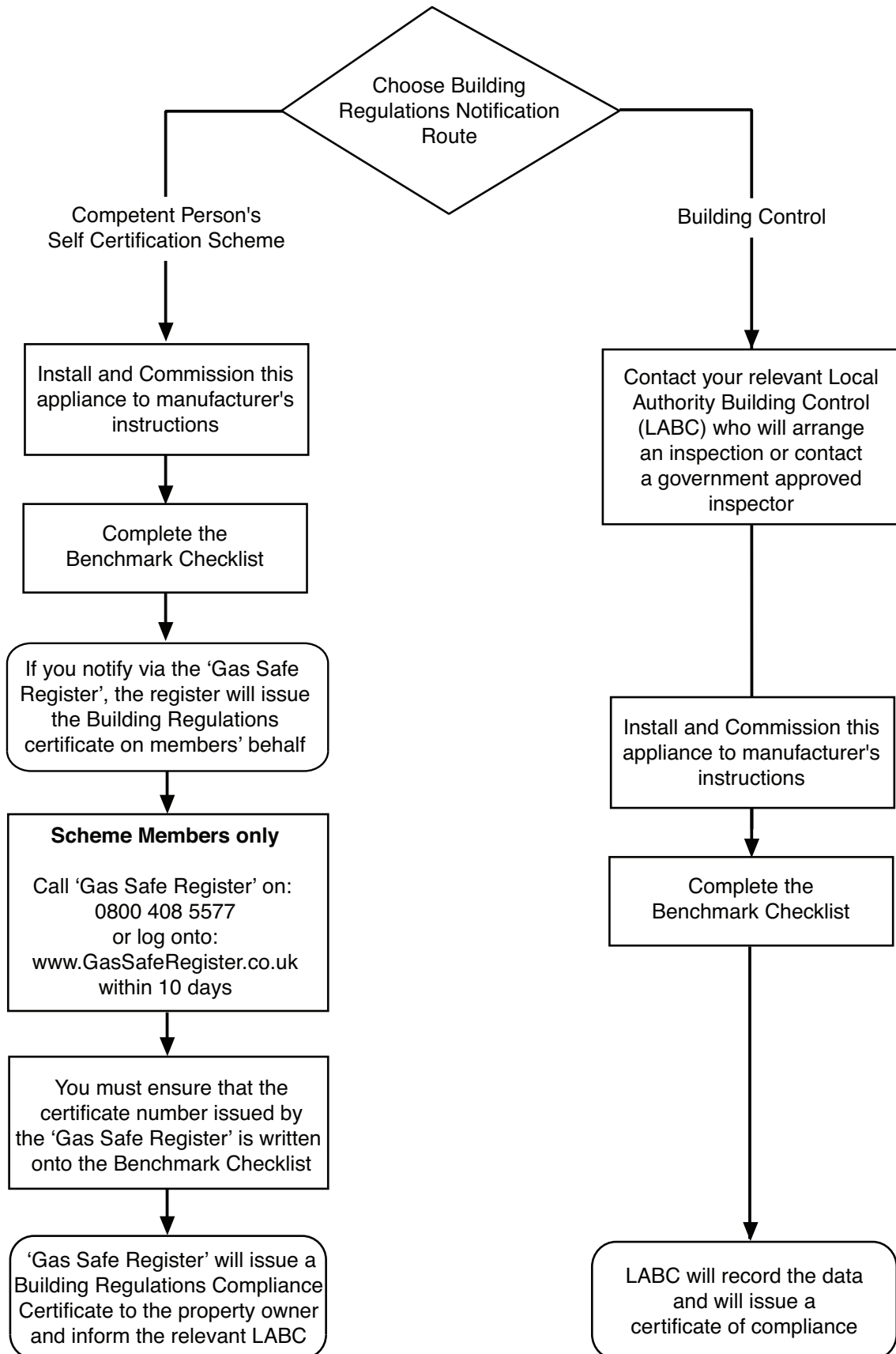

Contents

Panel Removal.....	
Technical Data.....	
Introduction.....	
Health & Safety Information.....	
Codes of Practice.....	
Storage, Unpacking and Handling.....	
1. Installation Requirements.....	
1.1 Gas Supply.....	
1.2 Electricity Supply.....	
1.3 Location of Boiler.....	
1.4 Compartment Installation & Ventilation	
1.5 Flue Systems.....	
1.6 Water Supply & Systems.....	
1.7 Discharge Pipework.....	
2. Installation.....	
2.1 Install the Boiler.....	
2.2 Connect the Flue System.....	
2.3 Connect the Gas Supply.....	
2.4 Connect the Condensate Pipe	
2.5 Connect the Water Supply	
2.6 Connect the Power Supply Cable.....	
2.7 Optional Immersion Heater.....	
2.8 How to Drain Hot Water Storage Cylinder.....	
2.9 Control Panel, Display & Diagnostics.....	
3. Commissioning.....	
3.1 Commission the Boiler.....	
3.2 Hand Over to the User.....	
4. Service & Replacement of Parts.....	
4.1 General Access.....	
4.2 Automatic Air Vent.....	
4.3 Expansion Vessel/Pump.....	
4.4 Pressure Sensor/Pressure Relief Valve.....	
4.5 Air/Gas Valve/Injector/Fan.....	
4.6 Spark Generator/Ignition Electrode.....	
4.7 Burner.....	
4.8 Boiler Control Assembly.....	
4.9 Diverter Valve Actuator.....	
4.10 Overheat Thermostat.....	
4.11 Diverter Valve Complete, Manual Air Vent and Temperature Flow, Return & Dry Fire Sensors.....	
4.12 Heat Exchanger.....	
4.13 Immersion Heater and Immersion Heater Combined Thermostat/Thermal Cut Out.....	
Gas/Air Valve Setup Procedure.....	
5. Wiring Diagrams.....	
6. Fault Finding.....	
Diagnostic Codes.....	
7. Short List of Spares.....	

The models covered by these instructions are:-

Promax HE Store	G.C. No.
90 Litres	41 601 24
115 Litres	41 591 76
150 Litres	41 591 77

Important

*Refer to Page 8 for **Storage, Unpacking and Handling Instructions.***

Benchmark Commissioning Checklist

Potterton is a member of the Benchmark initiative and fully supports the aims of the programme. Benchmark has been introduced to improve the standards of installation and commissioning of central heating systems in the UK and to encourage the regular servicing of all central heating systems to ensure safety and efficiency.

Important – Failure to install and commission this appliance to manufacturer's instructions may invalidate the warranty. This note does not affect your statutory rights.

Gas Safe

All Gas Safe registered engineers carry an ID card with their licence number and a photograph. You can check your engineer is registered by telephoning 0800 408 5500 or online at www.GasSafeRegister.co.uk

Safety, Performance & Quality

Promax HE Store boilers have been assessed by a Government appointed Notified Body and shown to meet the 'Essential Requirements' of the European Gas Appliance Directive 90/396/EEC.

The Directive lays down requirements for the safety and efficiency of the appliance, together with its design, construction, and use of materials.

It also requires the production process to be covered by an approved and monitored system of quality assurance.

Warning - The addition of anything that may interfere with the normal operation of the appliance without explicit written permission from the manufacturer or his agent could invalidate the appliance warranty. In GB this could also infringe the GAS SAFETY (Installation and Use) REGULATIONS.

Panel Removal

Important: Refer to Page 8 for Storage, Unpacking and Handling Instructions.

Top & Bottom Section

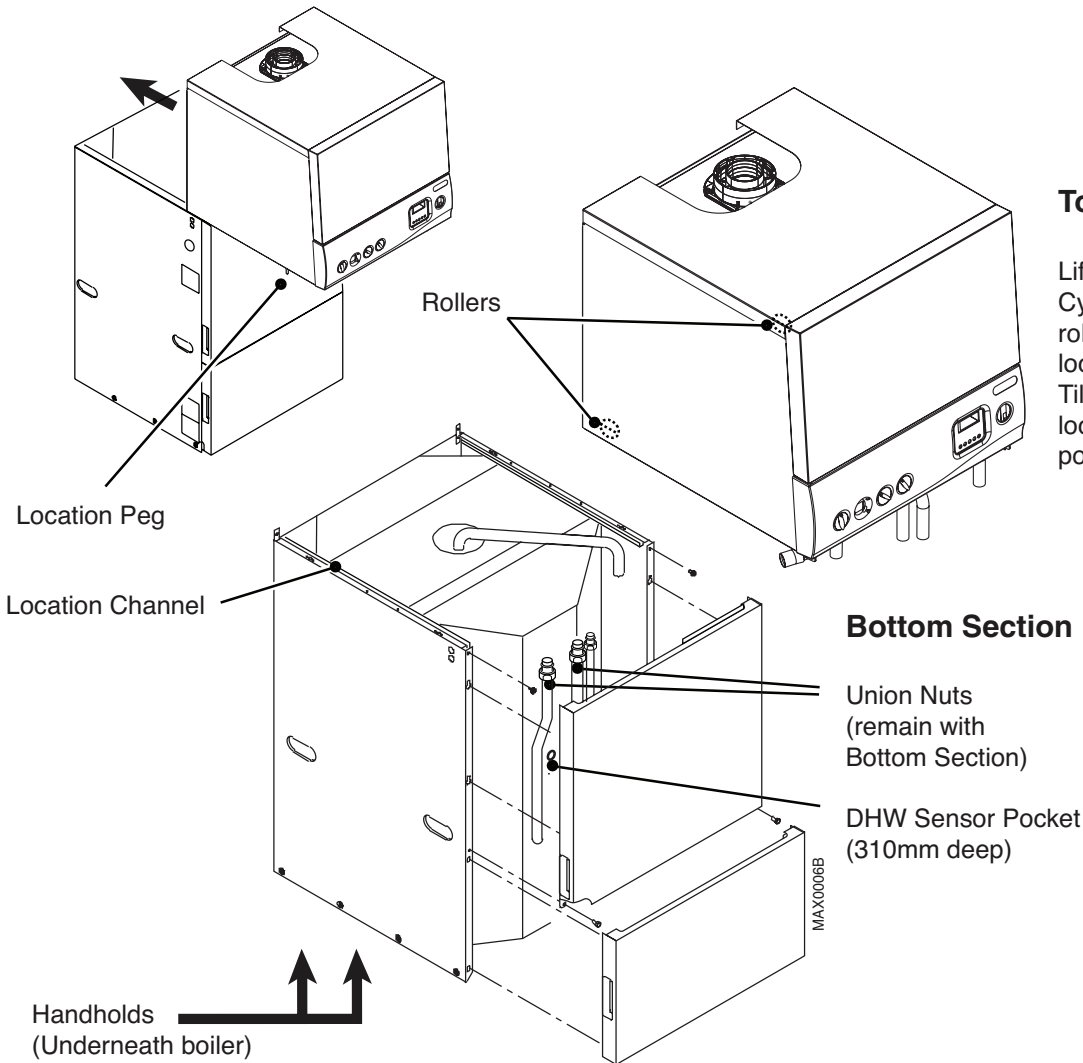

Plumbing Access

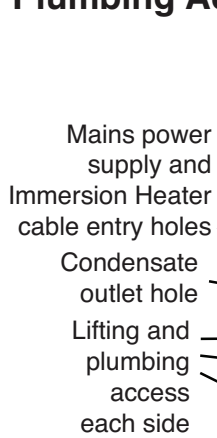

General Access

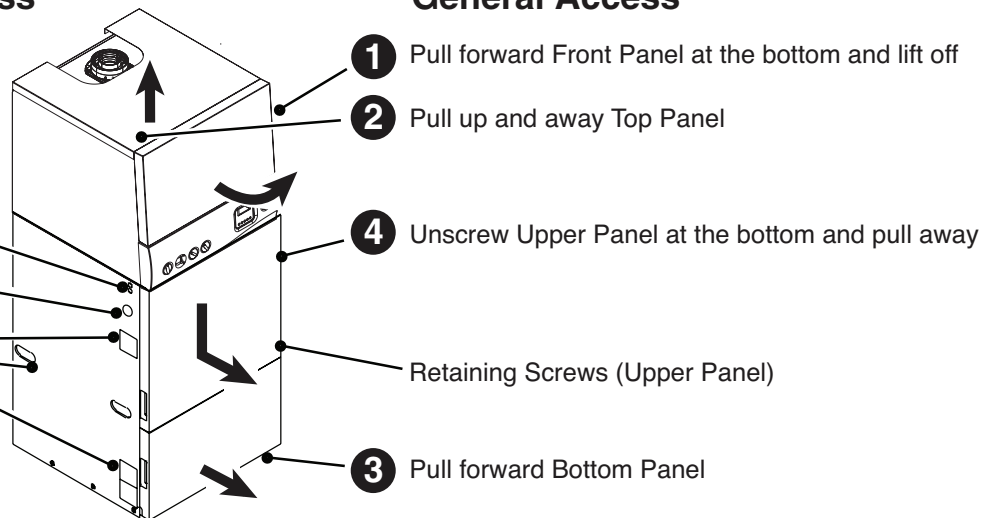

Fig. 1

Technical Data

Unless indicated, data shown relevant to all models			90 litre	115 litre	150 litre
Classifications	Appliance category Flue Type NOx Class Cylinder Insulation		CAT I ₂ H C ₁₃ - C ₃₃ - C ₅₃ (as supplied) 5 (< 70 mg/kWh) CFC, HCFC = 0%		
Input (hot water/central heating) - gross Output to CH (non-condensing) Output to CH (condensing)			7.8 - 27.4 kW 6.8 - 24.0 kW 7.6 - 25.9 kW		
Inlet pressure Gas rate (after 10 mins.)			20 mbar 2.6 m ³ /hr max.		
Gas control differential (offset) CO (average)			-3 Pa to - 8 Pa (- 0.03 to - 0.08 mbar) 70 ppm		
Ventilation Requirements:			No Compartment Ventilation Required		
Connections	CH Flow & Return DHW Inlet & Outlet Gas Temperature/Press. Relief Valve Condensate Outlet Inlet Control Group Filling Loop		22 mm 'Techtite'/compression 22 mm tube end 22 mm compression 22 mm compression from tundish. Flexible Pipe 500 mm long (fits 21.5 mm PP overflow systems) 22 mm compression inlet & outlet Set reduced pressure 2.5 bar, expansion relief valve set 8.0 bar 15 mm /1/2" union (accessible behind lower front panel)		
Secondary Expansion Vessel Automatic bypass			12 litre, pre-charge 2.5 - 2.7 bar (supplied separately) Built in		
Pressure loss warning Built in programmer External programmer Built-in room thermostat Built in frost protection			Gauge on facia 2-channel, pre-programmed, battery back-up, separate times for HW & CH, advance button, CH off selector Dedicated connectors on user terminal block Boiler protected below 5 °C		
Optional Immersion Heater			Heatrae 'Mega'. 3 kW at 240V, Advantica Approved		
Electricity supply Power Consumption (maximum)			230v ~ 3A fused supply, 166 Watts (Grundfos pump) 156 Watts (Wilo pump)		
Working pressures	Primary DHW Mains Supply Pressure Relief Valve (Primary) Temperature/Press. Relief Valve		0.9 - 2.5 bar 1.0 - 2.5 bar 1.0 - 16.0 bar 3.0 bar Pre-set 95 °C, 10.0 bar opening		
DHW temperature DHW flow rate (Practical maximum assuming suitable mains supply)			30 °C to 60 °C 25 l/m max. 25 l/m max. 25 l/m max.		
Weights	Lift Weight Heat Engine Cylinder Full Weight		45 kg 37 kg 171 kg 41 kg 202 kg 49 kg 246 kg		

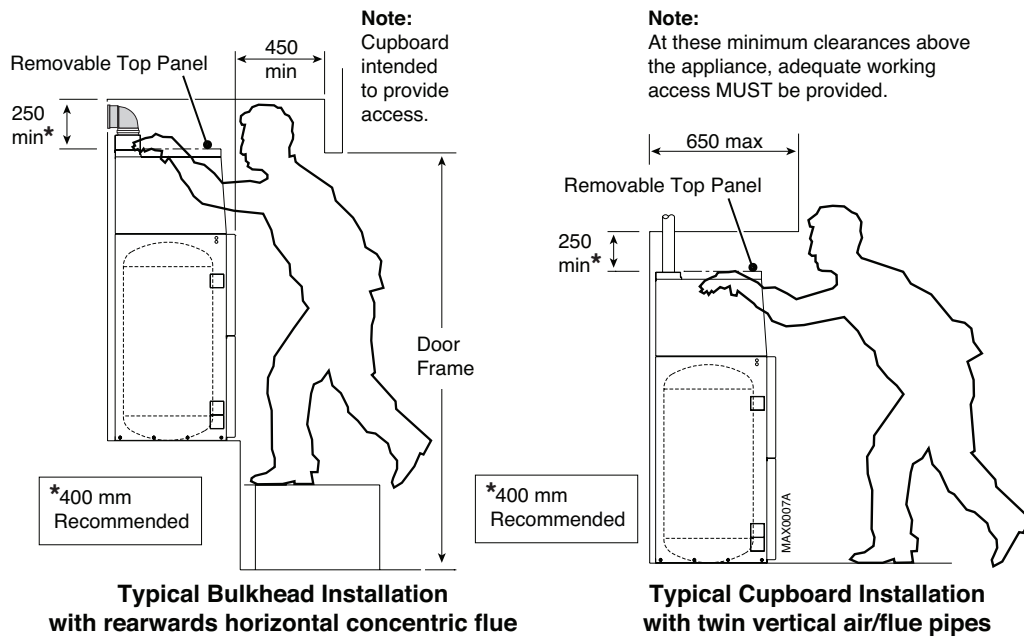

Fig. 2

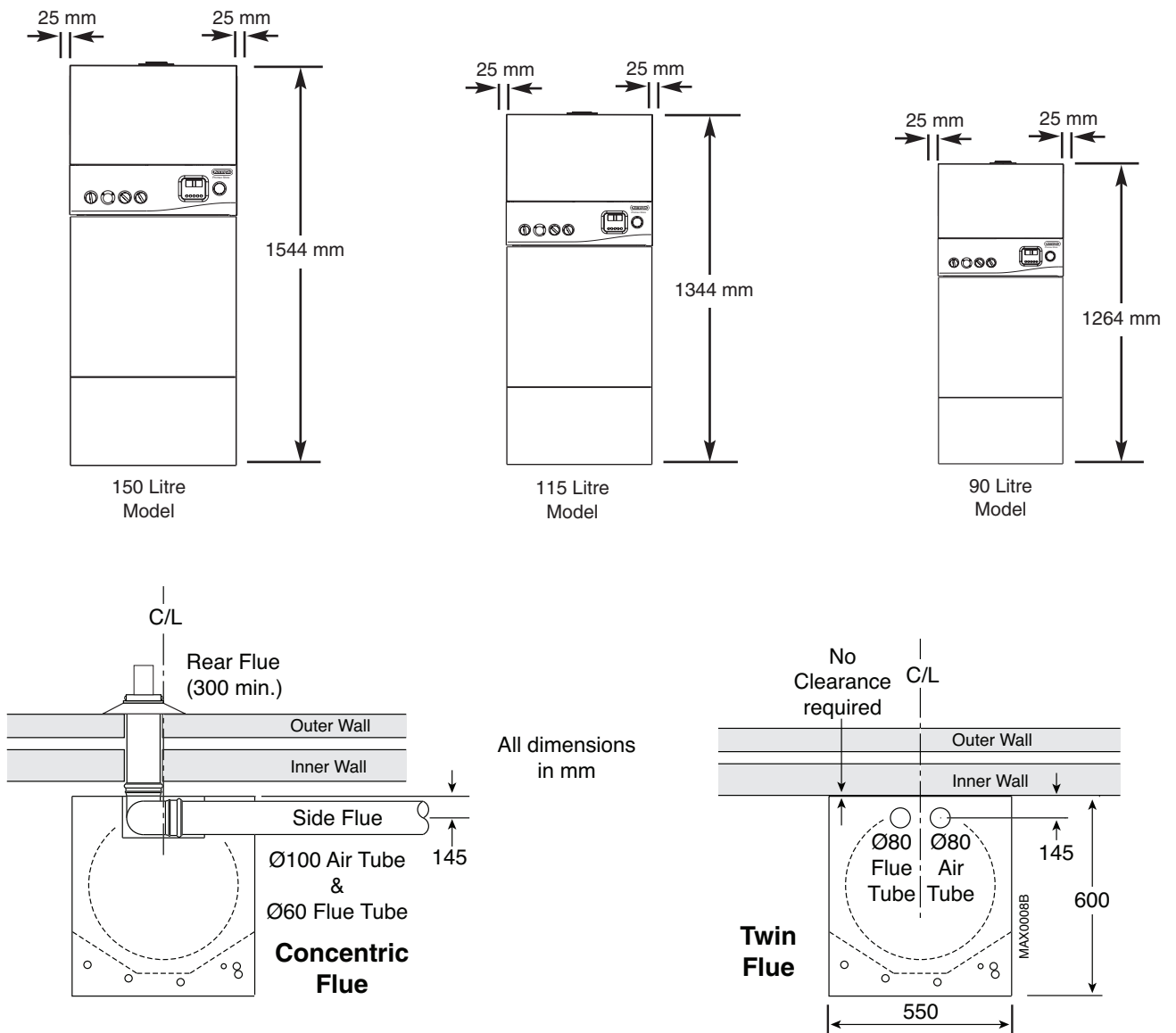

Fig. 3

Introduction

Important - Installation, Commissioning, Service & Repair

This appliance must be installed in accordance with the manufacturer's instructions and the regulations in force.

Read the instructions fully before installing or using the appliance.

In GB this must be carried out by a competent person as stated in the Gas Safety (Installation & Use) Regulations.

Definition of competence: A person who works for a Gas Safe registered company and holding current certificates in the relevant ACS modules, is deemed competent.

In IE this must be carried out by a competent person as stated in I.S. 813. "Domestic Gas Installations".

Read the instructions fully before installing or lighting the boiler.

Promax HE Store is a floor standing condensing combination boiler which incorporates a hot water store to provide domestic hot water (DHW) and central heating (CH). The DHW temperature is user adjustable (e.g. for summer/winter operation). Operation is automatic and the fully modulating pre-mixed burner ensures that gas is burned cleanly and efficiently within the condensing heat exchanger. An advanced burner control includes flame monitoring, pressure monitoring and other safety features, plus status and diagnostic displays which are large and easy to read.

Installation of this boiler as an unvented hot water system falls within the scope of the Building Regulations 1995 (Part G). These require that installation of an 'unvented' system shall be notified to the local authority Building Control Department; also that the work must be carried out by a competent person as defined in the Approved Document G3. The above requirements do not apply if hot water is obtained via an open vented feed tank.

Samples of the Promax HE Store gas boilers have been examined by DVGW Technologies Limited, a EU Notified Body. The range is certified to comply with the essential requirements of the Gas Appliance Directive 90/396/EEC, the Low Voltage Directive 72/23/EEC and shows compliance with the Electro Magnetic Compatibility Directive 89/336/EEC, the Boiler Efficiency Directive 92/42/EEC and are therefore permitted to carry the CE Mark.

Operation

The boiler control works on the principle of "hot water priority" so the central heating output may be temporarily delayed if the hot water temperature drops below the selected temperature e.g. after drawing a hot bath. The selected temperature is user adjustable in the range 45° to 65 °C

To suit conventional radiator based central heating systems, the boiler will normally provide a flow temperature of around 80 °C. The boiler control automatically responds to lower central heating loads by reducing the boiler output (which saves wasteful on-off cycling).

This boiler must be installed into a sealed (pressurised) primary system.

Provision is made for fitting both room and frost thermostats if required. **Note:** The boiler has its own in-built frost protection which will seek to prevent the boiler temperature dropping below 5 °C

For summer operation the user can switch off the central heating at the control panel.

Visible Plumbing

The efficient condensing operation of Promax HE Store will naturally cause condensate to form in the flue pipe and plumbing of the condensing gases will be visible during all but the most favourable atmospheric conditions. In installations with long flue runs, some condensate may be discharged from the terminal. The flue terminal must, therefore, be sited to avoid nuisance from either phenomenon.

Delivery & Kits Available

Promax HE Store boilers are delivered in three packages (1) the heat engine and unvented accessory kit, (2) the hot water cylinder and (3) the flue kit. The flue kit must be ordered/specified additionally to the boiler.

Health and Safety Information for the Installer and Service Engineer

Under the Consumer Protection Act 1987 and Section 6 of the Health and Safety at Work Act 1974, we are required to provide information on substances hazardous to health.

This boiler does not contain substances harmful to health; it does not contain asbestos. Small quantities of adhesives and sealants used in the product are cured and present no known hazards.

Codes of Practice

The appliance is suitable only for installation in GB and IE and should be installed in accordance with the rules in force.

In GB, the installation must be carried out by a Gas Safe Registered Installer. It must be carried out in accordance with the relevant requirements of the:

- Gas Safety (Installation & Use) Regulations.
- The appropriate Building Regulations either The Building Regulations, The Building Regulations (Scotland), Building Regulations (Northern Ireland).
- The Water Fittings Regulations or Water Byelaws in Scotland.
- The Current I.E.E. Wiring Regulations.

Where no specific instructions are given, reference should be made to the relevant British Standard Codes of Practice.

In IE, the installation must be carried out by a Competent Person and installed in accordance with the current edition of I.S. 813 "Domestic Gas Installations", the current Building Regulations and reference should be made to the current ETCI rules for electrical installation.

In GB the following Codes of Practice apply:
Standard Scope

- | | |
|----------------------------|---|
| BS6891 | Specification for low pressure gas pipework in domestic premises. |
| BS5440 Pt.1
BS5440 Pt.2 | Specification for installation of flues.
Specification for installation of ventilation for gas appliances (except that compartment ventilation is amended in section 8 of these instructions). |
| BS5546 | Specification for installation of gas hot water supplies. |
| BS5449 | Specification for forced circulation hot water central heating systems. |
| BS6798 | Specification for installation of gas fired hot water boilers of rated input not exceeding 70kW. |

In IE:
I.S. 813 Domestic Gas Installations.

The following BS standards give valuable additional information:

- | | |
|--------|---|
| BS6891 | Specification for low pressure gas pipework in domestic premises. |
| BS5546 | Specification for installation of gas hot water supplies. |
| BS5449 | Specification for forced circulation hot water central heating systems. |

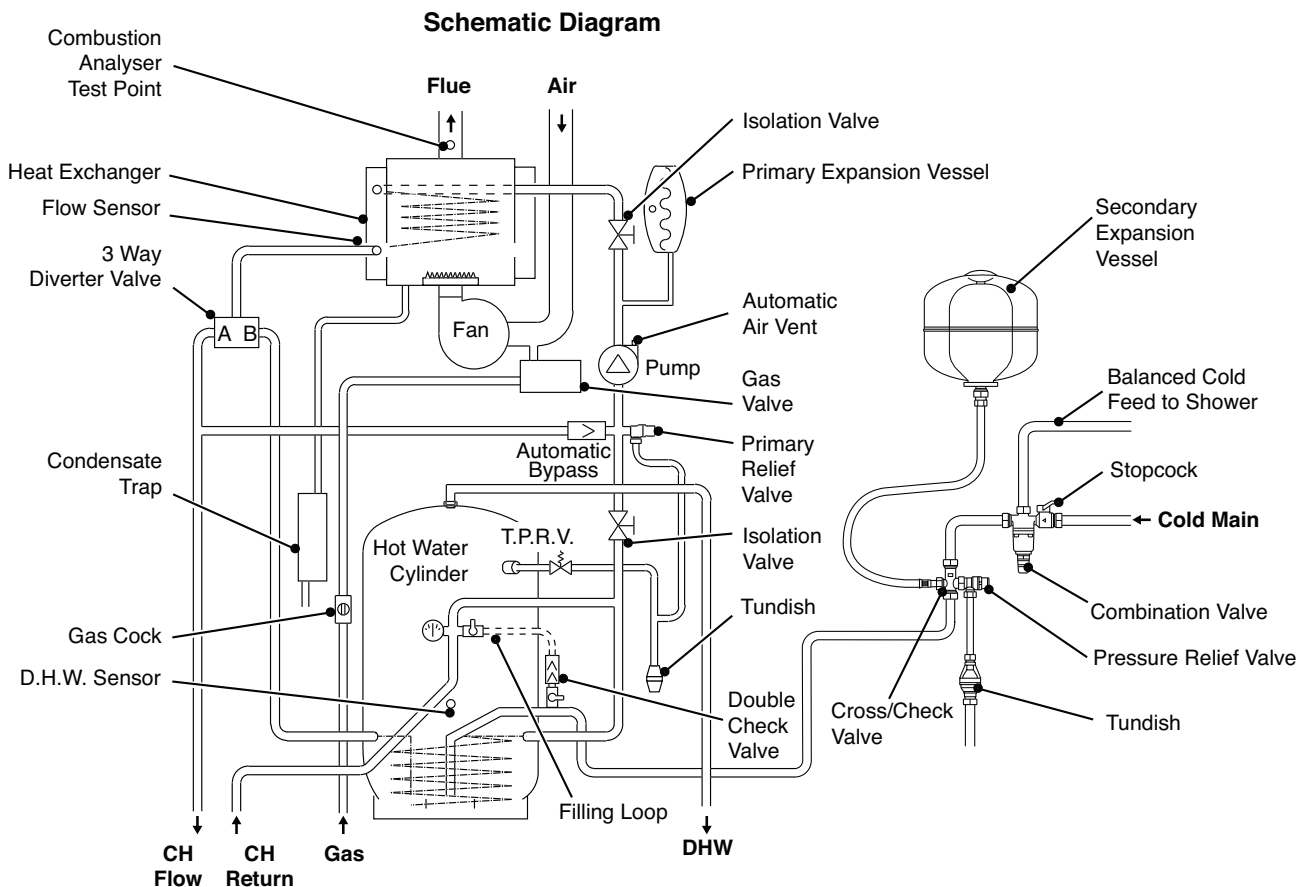

Fig. 4

1. Installation Requirements

Storage, Unpacking & Handling

This boiler is delivered in two sections for safety and ease of handling. Store both the Top (heat engine) and the Bottom (cylinder) under cover in dry conditions.

Remove the Promax HE Store unvented Accessory Kit from above the heat engine to reduce lift weight. (The front and top panels can also be removed if required - see Fig. 1).

Handholds are provided at the top rear of the heat engine and will assist with removing it from the transport tray. Handholds are provided at both sides and underneath the cylinder.

Use a handling device e.g. sack truck, to manually move either section over long distances. Trucking must be done from the rear. Take particular care to avoid damaging outer panels or programmer.

These items should be lifted and handled by two people. Stooping should be avoided and protective clothing worn when necessary. Carrying and lifting equipment should be used as required for moving Top and Bottom to where they will be assembled and installed..

Determine beforehand whether the Top and Bottom should be assembled to enable the complete unit to be moved into position, or whether to fit the cylinder and then lift the heat engine into position.

The Top has 2 downward facing dowel pins which provide accurate location on to the cylinder. Take care to avoid trapping hands and fingers during assembly.

Take great care when manoeuvring the boiler into its final location and avoid twisting movements of the body. **Do not attempt to carry the complete boiler as the Top is only doweled to the Bottom.**

Dispose of packaging in accordance with environmental guidelines.

1.1 Gas Supply

Entry holes are provided in the base and via knockouts in the side panels.

This boiler requires a natural gas supply of 2.6 cubic metres per hour. A 22 mm gas inlet connection is provided at the front and gas supply pipework of not less than 22 mm diameter should be run to the boiler. The meter and supply pipes must be capable of delivering this quantity of gas in addition to the demand

from any other appliances in the house and must be governed at the meter.

The gas installation should be in accordance with the relevant standards. In GB this is BS 6891. In IE this is the current edition of I.S. 813 "Domestic Gas Installations".

The whole of the gas installation must be checked for soundness and purged in accordance with, in GB, BS 6891 and in IE, I.S. 813 "Domestic Gas Installations".

1.2 Electricity Supply

The boiler requires a 230V ~ 50Hz single-phase 3A fused electrical supply. External wiring must be correctly earthed, polarised and in accordance with relevant regulations/rules. In GB this is the current I.E.E. Wiring Regulations. In IE reference should be made to the current edition of the ETCI rules.

Detailed wiring instructions are given in Section 10. Power consumption is approximately 90 - 166 W.

WARNING: THIS BOILER MUST BE EARTHED

In the event of an electrical fault after installation of the boiler, preliminary electrical systems checks must be carried out i.e. Earth Continuity, Short Circuit, Polarity and Resistance to Earth.

1.3 Location of Boiler

The boiler must not be sited outside or in any outhouse where it could be exposed to the weather.

The boiler must be installed on a flat floor capable of supporting the weight of the unit when full of water – up to 250 kg for the 150 litre model.

It should be sited to minimise the length of flue and to avoid long hot water pipe runs.

The extended flueing capability enables the boiler to be sited well away from an outside wall, thus installation in a first floor cupboard or compartment, basement, utility room or kitchen are all feasible locations.

The location chosen must permit the provision of a satisfactory external flue termination. The location must also provide adequate space for servicing and air circulation.

If floor settlement is likely due to the weight of the boiler, ensure that both the flueing and pipework layouts safely provide sufficient flexibility.

If the boiler is to be fitted in a room containing a bath or shower reference must be made to the relevant requirements.

In GB this is the current I.E.E. Wiring Regulations and Building Regulations.

In IE reference should be made to the current edition of I.S. 813 "Domestic Gas Installations" and the current ETCI rules.

1.4 Compartment Installation and Ventilation

General guidance for cupboard/compartment installations, including airing cupboards, is contained in BS 6798. Specific requirements for Promax HE Store are given below.

1. The compartment should be a fixed rigid structure large enough to allow it and the boiler to be inspected and serviced. A minimum width between the door jambs of 570 mm must be provided.
2. Minimum clearances are indicated in Fig.3. A full height compartment door must be at least 15 mm from the front of the boiler and provide 200 mm access height above the boiler.
3. Householders should be discouraged from storing clothes etc. on the boiler itself. A removable shelf at least 75 mm above the boiler is acceptable.
4. The internal surfaces of an understairs cupboard must be lined with non-combustible materials. The door shall have a BS 476 fire resistance of not less than 0.5 hour.

VENTILATION

1. Where the appliance is installed in a cupboard or compartment, no air vents are required.
2. BS 5440: Part 2 refers to room sealed appliances installed in compartments. The appliance will run sufficiently cool without ventilation.

1.5 Flueing

This is a "room sealed" condensing boiler. Flue systems are supplied in kits, or components can be ordered individually from Potterton. Only Promax HE Store flue components (which are designed for condensing operation) can be used.

Flue Systems

All boilers are supplied to accept either the concentric horizontal flue system or the Promax 80 mm dia. twin flue system, however several flue system options are available.

Each system is room sealed and offers a choice of flue type and termination method, (page 16).

- Concentric balanced flue with horizontal terminal
- Twin flue with vertical terminal *

Flue extension lengths and bends should be purchased separately, as required.

* These terminals must be ordered/specified separately.

General Requirements for Horizontal Flue Terminations

Detailed recommendations for flueing are given in BS5440: Part 1. The following notes give general guidance. The horizontal balanced flue terminal must be installed so that it is exposed to external air, preferably on a clear expanse of wall. Acceptable positions are indicated in Fig. 5. Avoid positions where the terminal is adjacent to projections; particularly immediately under a balcony, inside a re-entrant position, or immediately adjacent to a drain pipe. If the boiler is fitted under a ventilator or opening window, the terminal must be at least 300 mm from any part of the window or ventilator and in accordance with BS5440: Part 1.

The flue pipe must not be closer than 25 mm to combustible material. Additional clearance must be provided when passing the flue through timber walls. Advice on gas installations in timber framed buildings is contained in IGE technical publication IGE/UP/7 available from the Institution of Gas Engineers, 21 Portland Place, London W1N 3AF.

Guidance notes for Flue Installation

Read these Installation Instructions before installing the boiler. Before starting an installation, check that the correct flue kit has been supplied with the boiler.

Detailed recommendations for flue installations are given in BS 5440:1: 2000. The following notes are for general guidance only.

- a) The flue system must be constructed using only Promax approved components.
- b) It is important that the position of the terminal allows free passage of air across it at all times.
- c) It is **ESSENTIAL TO ENSURE** that products of combustion discharging from the terminal cannot re-enter the building, or any other adjacent building, through ventilators, windows, doors, other sources of natural air infiltration, or forced ventilation / air conditioning.
- d) The minimum permissible dimensions between the flue terminal and obstructions and ventilation openings are specified in the table on page 13 of these instructions.
- e) If the flue terminal discharges into a pathway or passageway check that combustion products will not cause nuisance and that the terminal will not obstruct the passageway.
- f) Where terminals are fitted within 850 mm of a plastic or painted gutter, or 450 mm of painted eaves, an

aluminium shield at least 750 mm long must be fitted to the underside of the plastic or painted surface.

- g) Where installation will be in an unusual location, special procedures may be necessary. BS 6798 gives detailed guidance on this aspect.
- h) As the Promax Store is a condensing boiler the flue duct must have a fall back to the boiler of at least 1.5°.
- j) The efficient condensing operation of the Promax HE Store will naturally give rise to condensation in the flue gases and **pluming will occur in all but the most favourable atmospheric conditions**. Some condensate may also be discharged from the terminal. The terminal must, therefore, be **sited to avoid nuisance from either phenomenon**.
- k) Where the lowest part of the terminal is less than 2 m above the level of any ground, balcony, flat roof or place to which people have access, the terminal must be protected by a guard of durable material.

IMPORTANT: If fitting a Plume Displacement Flue Kit, the air inlet must be a minimum of 100mm from any opening windows or doors

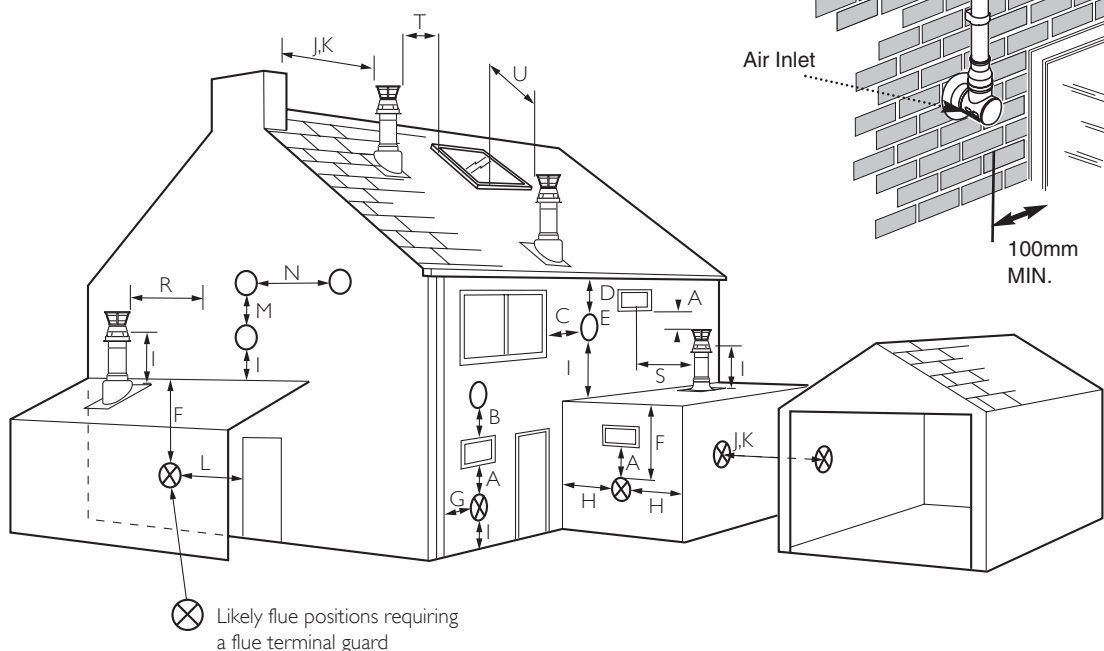
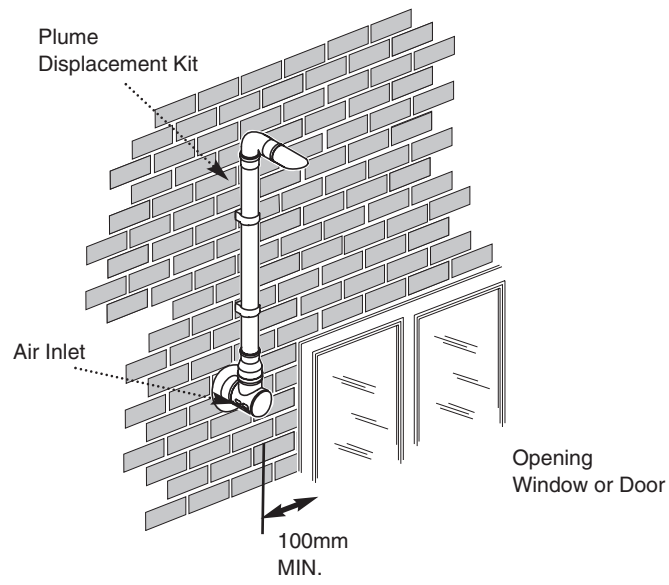

**Terminal Position with Minimum Distance (mm)
For IE, refer to I.S. 813 "Domestic Gas Installation".**

Fanned Draught Balanced Flue

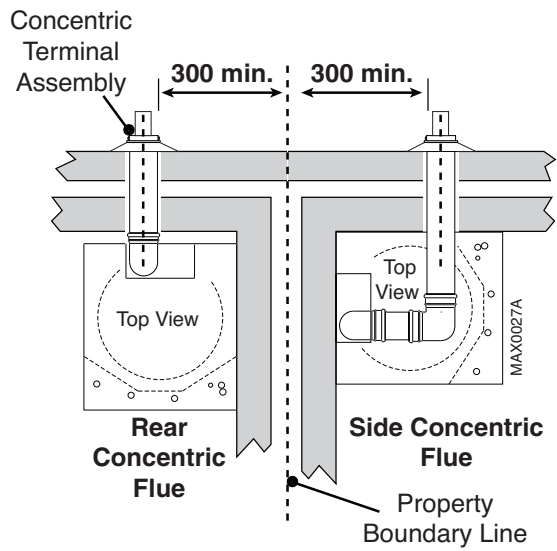

A ^a Directly below an opening, air brick, opening windows, etc.	300
B ^a Above an opening, air brick, opening window etc.	300
C ^a Horizontally to an opening, air brick, opening window etc.	300
D Below gutters, soil pipes or drain pipes.	25
E Below eaves.	25
F Below balconies or car port roof.	25
G From a vertical drain pipe or soil pipe.	25
H From an internal or external corner.	25
I Above ground, roof or balcony level.	300
J From a surface or boundary line facing a terminal.	600
K From a terminal facing a terminal (Horizontal flue).	1200
From a terminal facing a terminal (Vertical flue).	600
L From an opening in carport (e.g. door, window) into the dwelling.	1200
M Vertically from a terminal on the same wall.	1500
N Horizontally from a terminal on the same wall.	300
R From adjacent wall to flue (vertical only).	300
S From an adjacent opening window (vertical only).	1000
T Adjacent to windows or openings on pitched and flat roofs	600
U Below windows or openings on pitched roofs	2000

^a In addition, the terminal should not be nearer than 150 mm to an opening in the building fabric formed for the purpose of accommodating a built-in element such as a window frame. See BS 5440 Pt. 1.

Note: The distance from a fanned draught appliance terminal installed parallel to a boundary may not be less than 300 mm in accordance with the diagram on the left.

IMPORTANT:

- Only **ONE** 25mm* clearance is allowed per installation.
- Under car ports we recommend the use of the plume displacement kit.
- The terminal position must ensure the safe and nuisance - free dispersal of combustion products.

Fig. 5

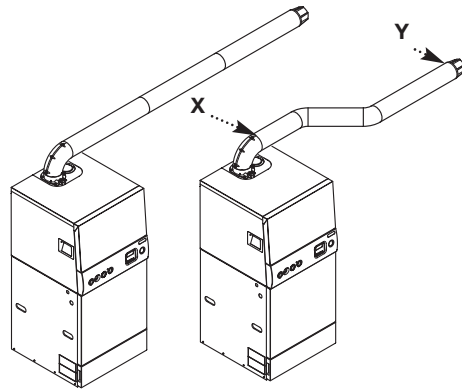
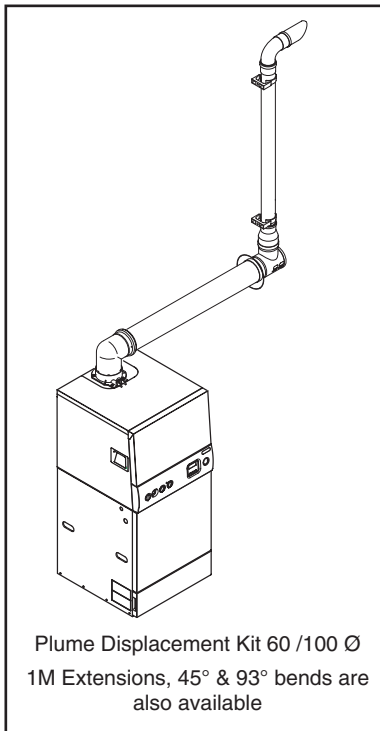

Horizontal Flues

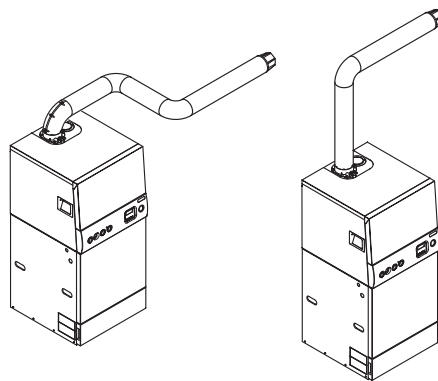

Flue Options

1. The Promax Store can be fitted with flue systems as illustrated.
2. The standard flue kit, Part No. 5118489 comprises a concentric 100/60 terminal and a 93° bend. It is suitable only for horizontal termination applications.

3. Maximum permissible equivalent flue lengths are:-

Horizontal Concentric	10 metres
Vertical Concentric	10 metres
Vertical Twin Pipe	15 metres

4. Any additional "in line" bends in the flue system must be taken into consideration. Their equivalent lengths are:-

Concentric Pipes:

45° bend	0.5 metres
93° bend	1.0 metres

Twin Flue Pipe

45° bend	0.25 metres
91.5° bend	0.50 metres

The elbow attached to the boiler is not included in any equivalent length calculations

5. The illustrations opposite show examples of permissible flue systems.

NOTE: Horizontal flue pipes should always be installed with at least a 1.5° fall from the terminal to allow condensate to run back to the boiler.

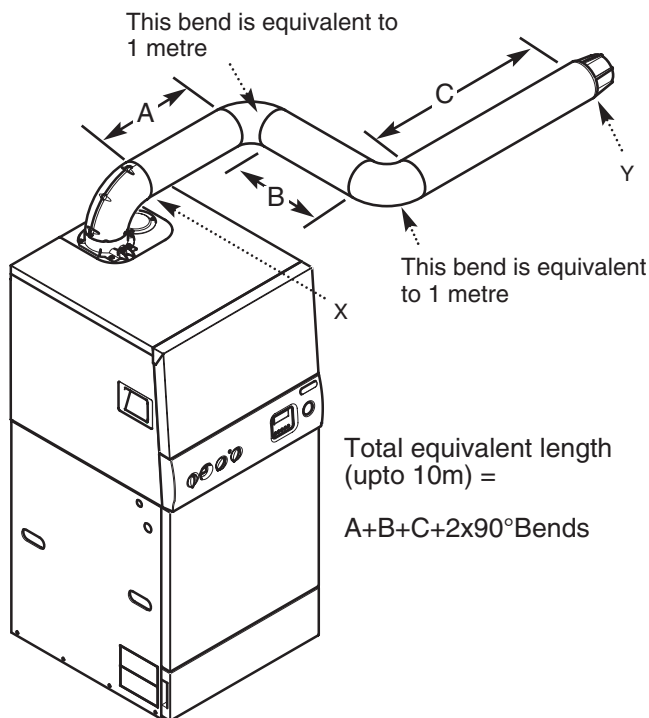

NOTE: Flue length is measured from point X to Y as shown.

IMPORTANT: All flue systems must be securely supported at least once every metre. Suitable pipe supports are available as accessories.

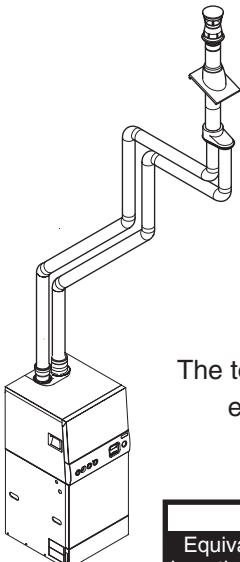
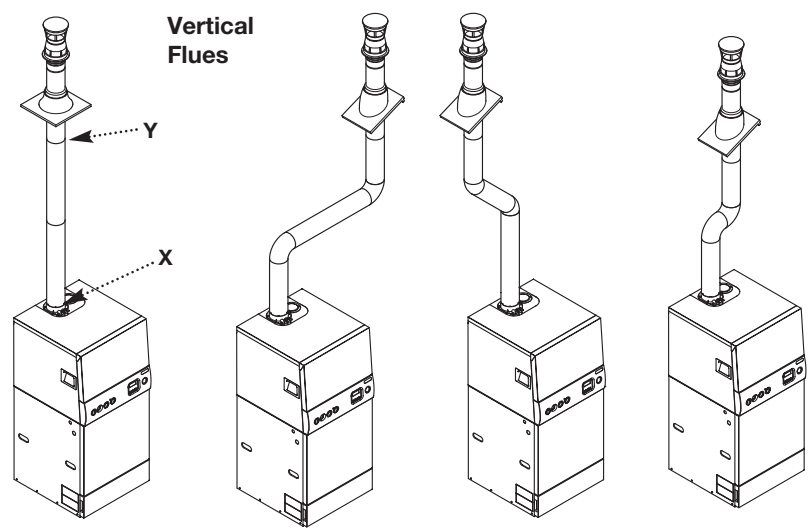
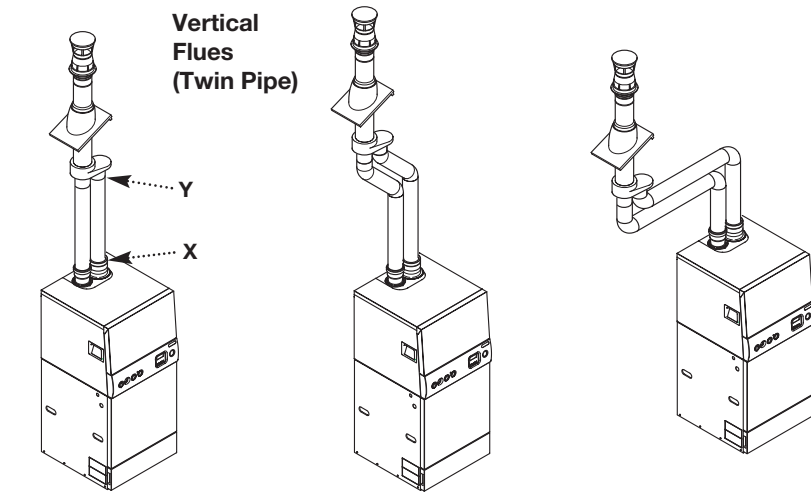
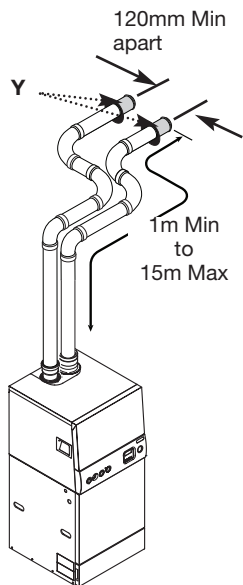
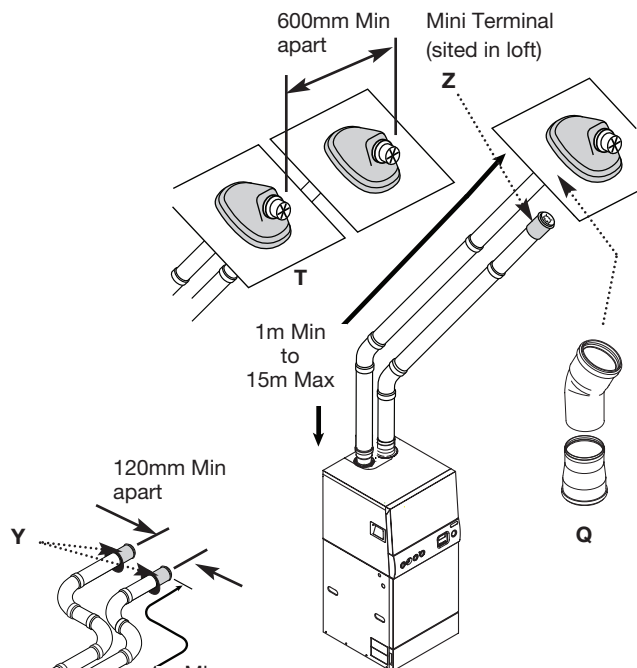

The total equivalent length for this example is = 6.5 metres.

AIR DUCT		
Equivalent Length Value	N° of fittings/pipes	Sub total
1m extension	5	5.0m
135°bend	2	0.5m
91.5°bend	2	1.0m
Equivalent Length Air Duct = 6.5m		

FLUE DUCT		
Equivalent Length Value	N° of fittings/pipes	Sub total
1m extension	5	5.0m
135°bend	2	0.5m
91.5°bend	2	1.0m
Equivalent Length Flue Duct = 6.5m		

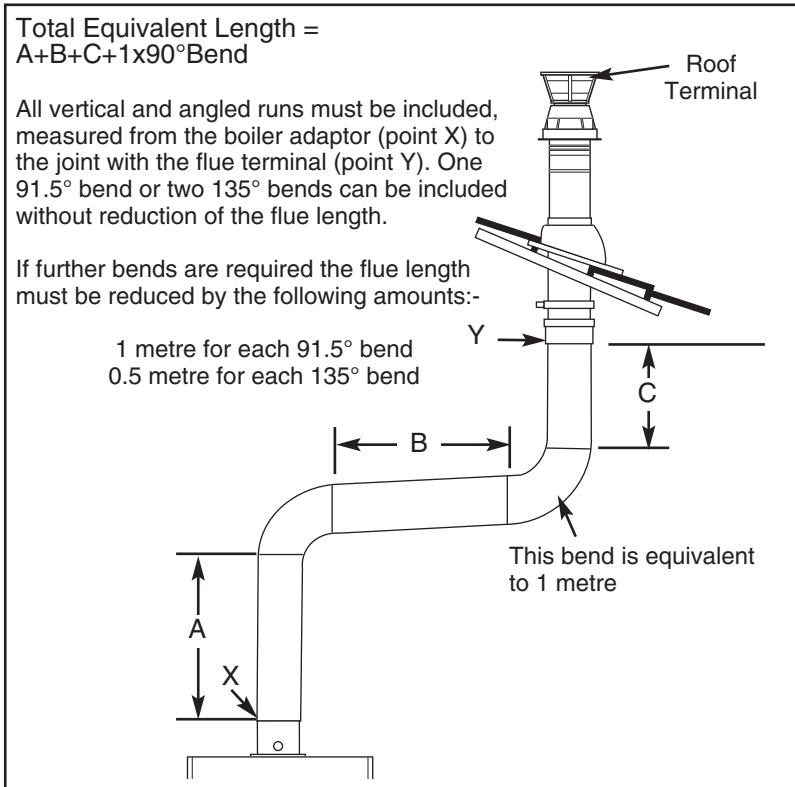

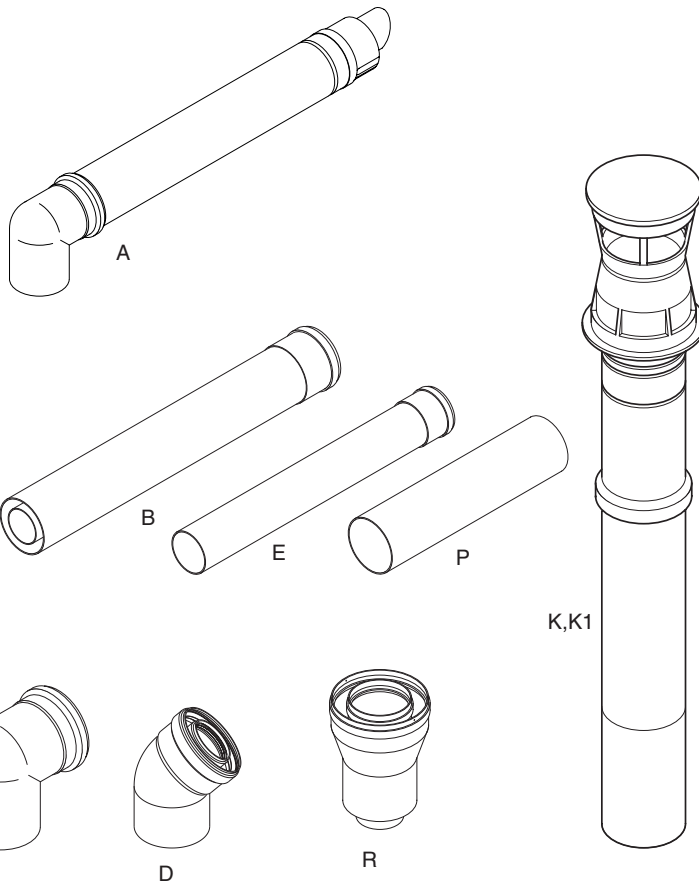

Flue Accessories

Key	Accessory	Size	Code No
-----	-----------	------	---------

FLUE GROUP A

Concentric Flue System 100mm diameter

A	Horizontal Flue Terminal (inc. elbow)		5118489
B	Flue Extension	1000mm	5111074
C	Flue Bend	93°	5111075
D	Flue Bend (pair)	135°	5111085
U	Pipe Support (painted)	100Ømm	5111080
R	Vertical Flue Adaptor		5111070
P	Wall Liner		5111067
S	Flue Terminal Deflector		5111068

FLUE GROUP N

Twin Flue System 80mm diameter

E	Flue Extension (pair)	1000mm	5111087
F	Flue Bend (pair)	90°	5111072
G	Flue Bend (2 pair)	135°	5111086
J	Vertical Flue Boiler Adaptor Kit		5111079
H	Vertical Flue Adaptor		5111084
W	Pipe Support (pair)	80mm	5111081
Y	Twin Flue Termination Kit (horizontal termination)	80mm	5120172
Z	Single Terminal	80mm	5121791
Q	Adaptor	60/80	5121792
T	Pitched Roof Terminal	25°/45°	5106164

FLUE GROUP A, N, G

Vertical Flue Kits

K	Vertical Flue Terminal (use with 5111070)		5111078
K1	Vertical Flue Terminal		5118576
L	Pitched Roof Flashing	25°/45°	246141
	Pitched Roof Flashing	35°/55°	246142
M	Roof cover plate		246143
N	Flat roof flashing		246144

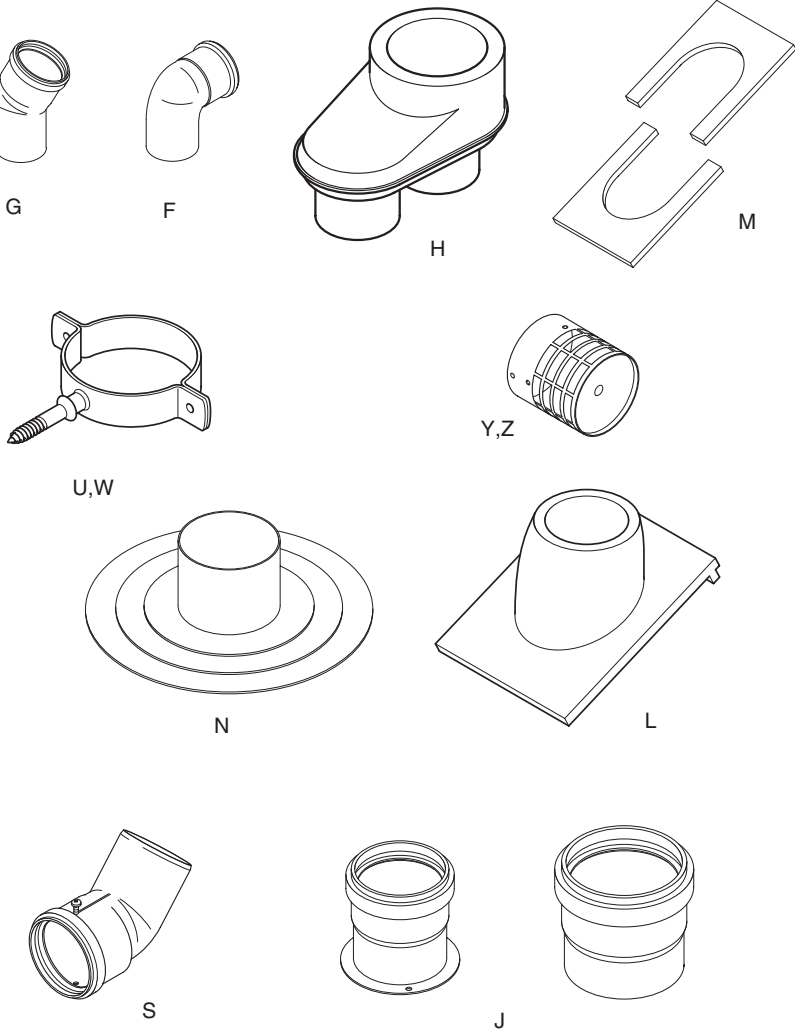

For Twin Flue Systems fit the adaptors as follows:-

Flue Duct Adaptor

1. Engage the flue duct adaptor on the boiler adaptor, making sure that it is pushed down as far as possible.

Air duct adaptor

1. Undo the screws securing the blanking plate to the boiler top panel. Discard the plate.

2. There are three restrictor plates supplied in the kit. One marked '23' and one marked '27', these can be discarded. **The third restrictor MUST be positioned as shown in the diagrams below.**

3. Take one of the gaskets supplied in the kit and place on the boiler top panel.

4. Align the appropriate restrictor as shown. Position the second gasket over the restrictor.

5. Using the screws previously removed secure the inlet adaptor to the top panel.

6. Continue to fit the twin flue system.

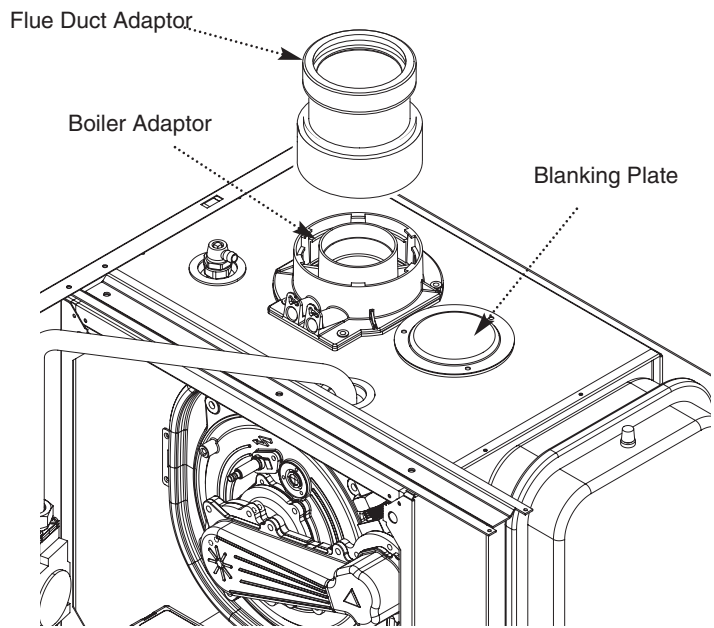

Position of Restrictor

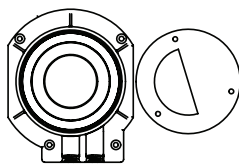

24 kW models

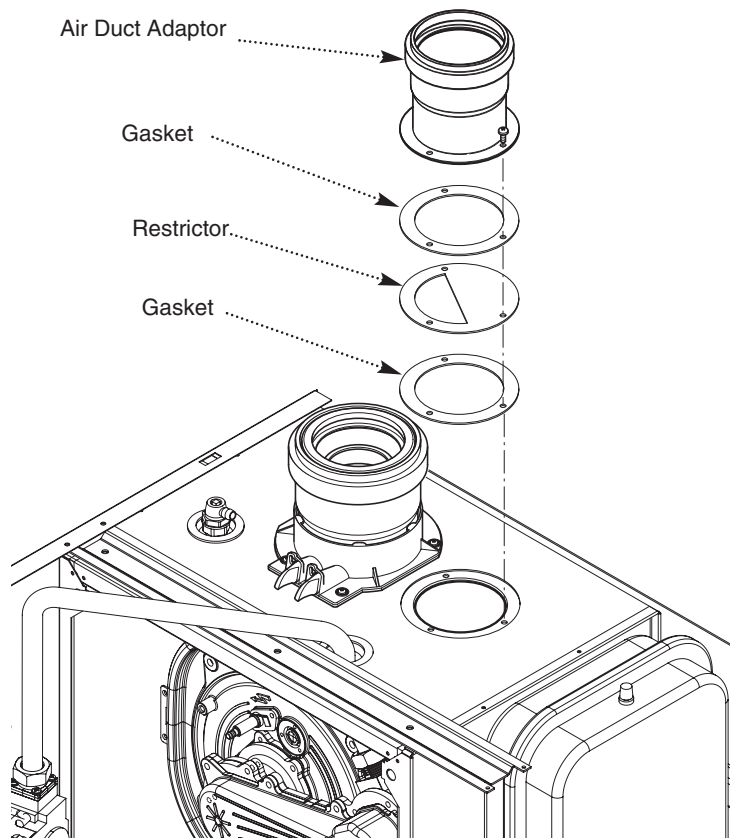

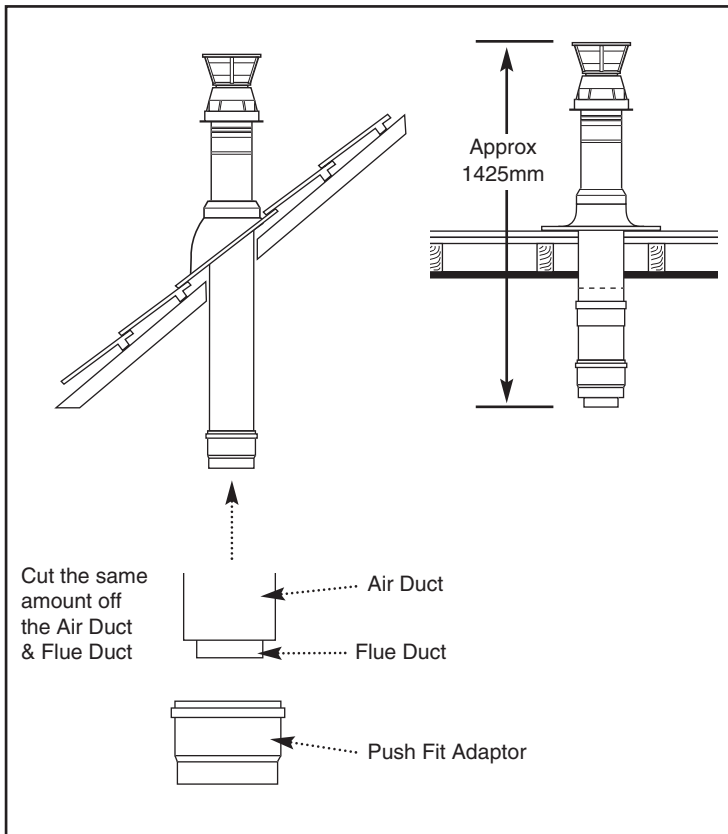

For Roof Terminals

1. In the case of a pitched roof 25 - 50 degrees, position the lead tile to replace/flash over existing roof tiling. Make an aperture in the roof suitable for the lower tube of the roof terminal and ensure the integrity of the roof cover is maintained. The adjustable plastic collar can either be positioned on the lead tile or the lower tube of the roof terminal prior to the final positioning of the vertical flue through the tile. Check the collar is correctly located to suit required roof pitch (either 25° to 38° or 37° to 50°). From inside the roof adjust the flue to a vertical position and secure to the roof structure with the clamp supplied.

2. For flat roof installations the aluminium flashing must be incorporated into the roof covering and the appropriate aperture made in the roof decking. The vertical flue is lowered onto the flashing making sure the collar of the flue locates securely with the flashing. (A mastic seal may be necessary). From inside the roof, adjust the flue to a vertical position and secure to the roof structure with the clamp supplied.

Flue Dimensions

The standard horizontal flue kit allows for flue lengths between 100mm and 685mm from elbow to terminal (Fig. 5a).

The maximum permissible equivalent flue length is:
10 metres (60/100 system)

Flue Trim

1. The rubber flue trim supplied may be fitted to either the outside wall or on the inner wall of installation.

Terminal Guard (Fig. 5c)

1. When codes of practice dictate the use of terminal guards, they can be obtained from most Plumbers' and Builders' Merchants.

2. There must be a clearance of at least 50mm between any part of the terminal and the guard.

3. When ordering a terminal guard, quote the appliance name and model number.

4. The flue terminal guard should be positioned centrally over the terminal and fixed as illustrated.

Flue Deflector (Fig. 5b)

1. If required a flue deflector is available from your Potterton stockist.

2. Push the flue deflector over the terminal end and rotate to the optimum angle for deflecting plume. Secure the deflector to the terminal with screws provided.

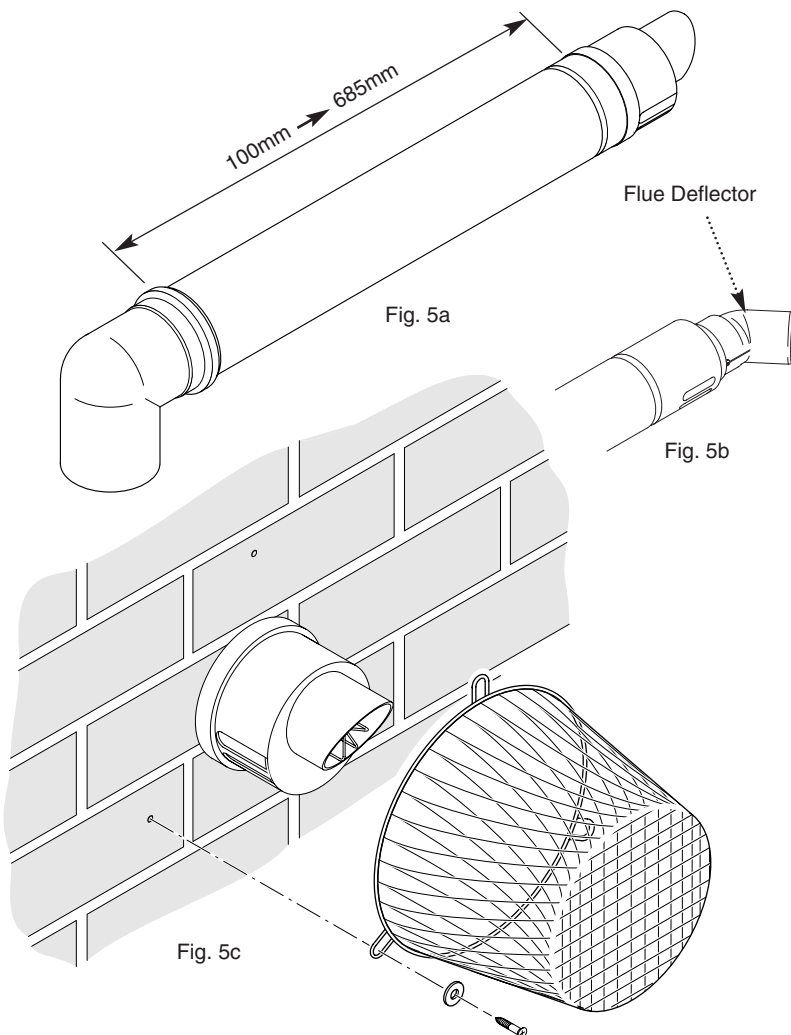

Plume Displacement Kit (Fig. 6a)

Kit No 5118638

Content of kit

- 1 0.9m 60/100 Concentric Flue
- 1 1m 60 Dia Exhaust Flue Pipe
- 1 Adaptor
- 2 60 Dia Support Brackets
- 1 93° Elbow/Plume Outlet Assembly
- 1 Flexible Flue Trim
- 3 "O" Rings
- 1 'Jubilee Clip
- 1 Boiler Elbow

1. This kit is recommended for installations where the condensate plume emitted from the flue may cause a nuisance or affect the surroundings.

2. The terminal must be positioned outside the building with the air inlet facing downward and outlet connection upwards.

3. The plume outlet must always be at least 45° to the wall, with the 'peak' uppermost to prevent rain entry (Fig. 6b), and be at least 2 metres above ground level. It must be secured with the support brackets. The plume outlet must also be at least 500mm from the air inlet in any direction (Fig. 6b).

NOTE: The outlet must be positioned so that any condensate plume is directed away from adjacent surfaces. There must be a constant fall along the entire length of the flue system from the outlet back to the boiler.

4. It is possible to reduce or increase (with the addition of extensions) the length of either or both the 60/100 concentric and 60Ø exhaust.

5. Standard concentric flue extension kits may be added between the boiler elbow and the terminal assembly.

6. The minimum length of the concentric flue is 100mm when measured from the edge of the flue elbow.

IMPORTANT: The maximum equivalent length of concentric flue is:- **8 metres**
Additional bends may be fitted in the concentric flue, but the equivalent length must be reduced by 1 metre (93° bend) or 0.5 metres (45° bend).

7. 60Ø 1 metre extensions (including support bracket), and additional 93° & 45° elbows are available. Any additional 93° & 45° elbows must be accounted for when calculating flue lengths.

NOTE: Permitted positions of the plume outlet relative to doors, windows etc. are the same as for conventional concentric flues as detailed in the main Installation & Servicing Instructions and BS5440 Pt.1. It is **NOT** necessary to fit a terminal guard over the air inlet or the plume outlet.

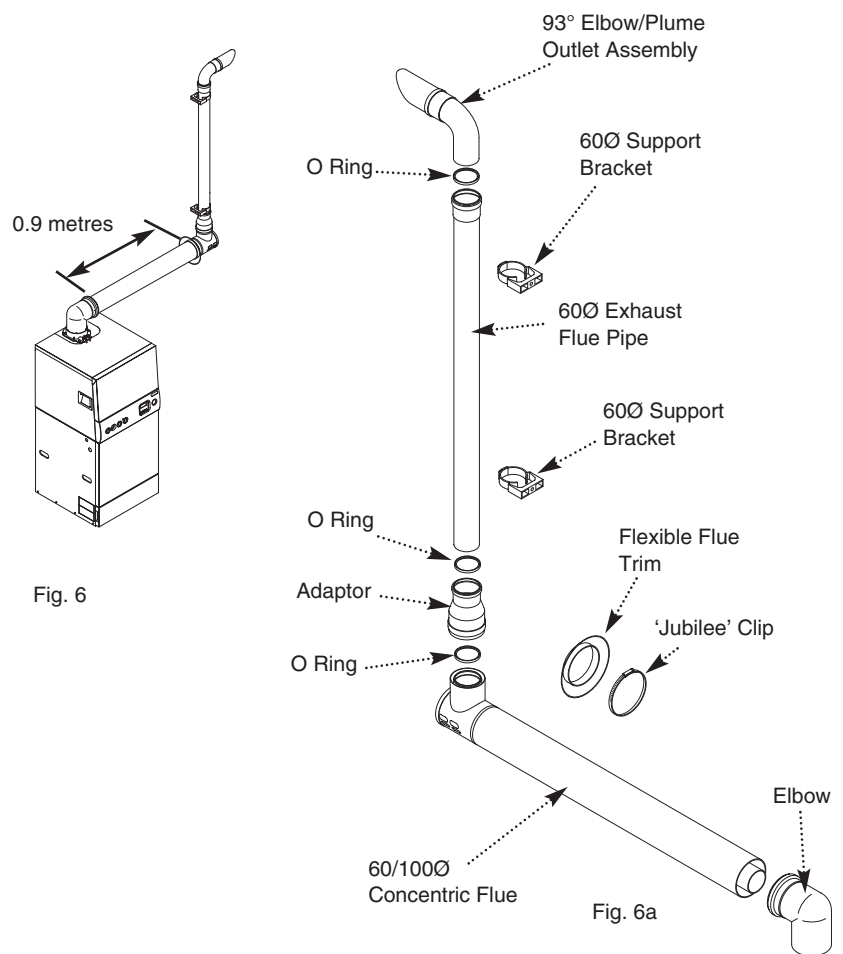

Fig. 6

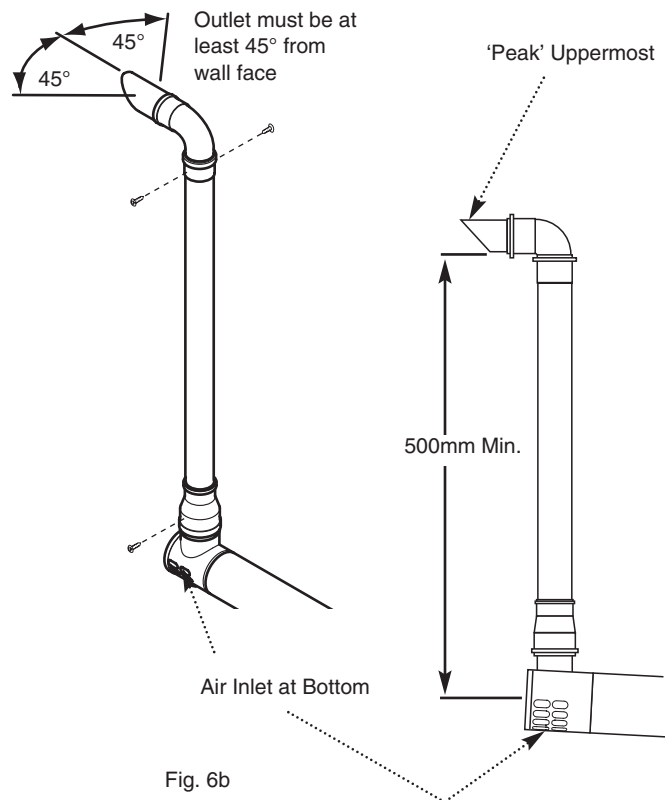

Fig. 6b

Determining Permissible Lengths

In the graph the solid line diagonal represents the relationship between the concentric flue assembly (and any extensions) and the 60Ø exhaust (and any extensions or additional bends).

Example 1 - Not Permissible

If, for instance, a concentric length of 5 metres was required and the 60Ø exhaust needed to be 10 metres the graph shows that this combination would NOT be permissible as the intersection point would be above the solid diagonal line.

Example 2 - Flue Lengths OK

Where both lengths have been determined they can be applied to the graph to check that the installation is permissible. For example, if it was known that 4 metres of concentric flue and 6 metres of 60Ø exhaust were required, the values could be applied to the graph as shown in Example 2. As the point of intersection of the dotted lines is below the solid diagonal line, the combination of lengths is shown to be acceptable.

Example 3 - Flue Lengths OK

In the example shown, assume that the concentric part of the flue needs to be 2 metres long. Find the position of '2' on the horizontal axis of the graph and then project upwards to the solid diagonal line. This is represented by the vertical thick dotted line. Where this dotted line intersects with the solid diagonal line on the graph, project across to the vertical axis. As can be seen this corresponds with 12 metres. Therefore, the total equivalent length of the 60Ø exhaust can be up to 12 metres. Any bend equivalencies must be accounted for i.e. 93° bends are equal to 1 metre, each 45° bend to 0.5 metres.

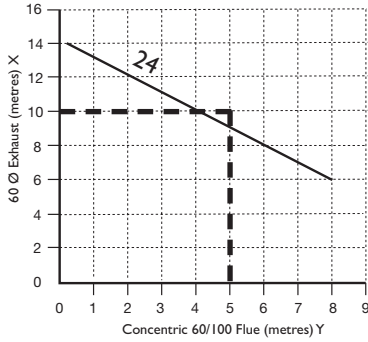

Example 1
Flue Lengths - Not Permissible

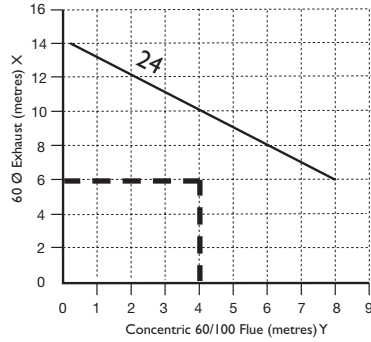

Example 2
Flue Lengths - OK

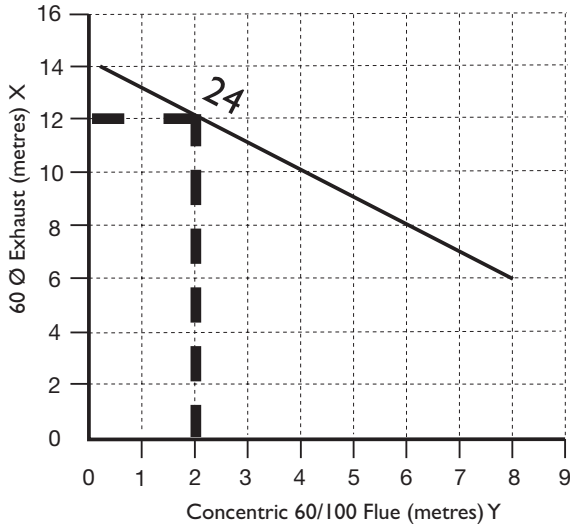

Example 3
Flue Lengths - OK

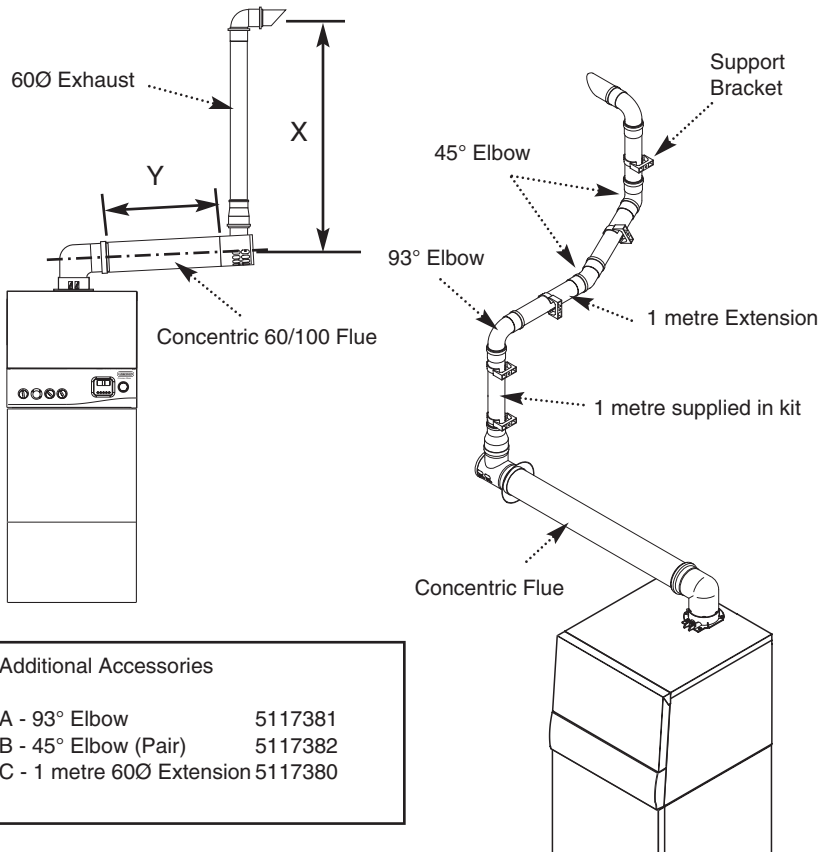

Additional Accessories

A - 93° Elbow	5117381
B - 45° Elbow (Pair)	5117382
C - 1 metre 60Ø Extension	5117380

Flue Length - Worked Example Potterton Promax Store

In diagram opposite an additional 93° bend and pair of 45° elbows have been included in the 60Ø exhaust. Also 3 straight extension pieces have been used.

To calculate total length:-

Length of 60Ø supplied in kit =	1 metre
3 x 1 metre Extensions =	3 metres
1 x 93° Elbow =	1 metre
2 x 45° Elbow =	1 metre (0.5 metres each)

Total 60Ø = 6 metres

After consulting the table in Example 3 it can be determined that the concentric flue could be up to approximately 8 metres long.

General Fitting Notes

1. Cut a hole in the external wall which the concentric flue assembly will pass through. The hole should allow the flue to fall back to the boiler at an angle of at least 1.5°.
2. When completed the terminal must be at least 2 metres above ground level (Fig. 7).
3. Measure and cut to size the concentric assembly and any extensions that are being used.
4. Insert the concentric assembly through the hole from outside the building.
5. If required, the flexible flue trim should be fitted prior to this as it cannot be fitted after. Use the large 'Jubilee' clip to secure the trim to the flue (See Fig. 7a, trim shown dotted), with the screw part of the clip at the bottom.
6. Connect any extensions or elbows that are being used to the concentric assembly. Engage the extension, elbow or concentric assembly in the boiler flue elbow. Fit the boiler flue elbow to the boiler adaptor.
7. Ensure that the concentric assembly and any extensions fall back to the boiler at an angle of at least 1.5° and that the external air inlet is to the bottom.
8. Use suitable brackets to support the concentric assembly and any extensions, and make good inside and outside.
9. The 60Ø exhaust can now be fitted. Slide the adaptor over the plain end of the 60Ø exhaust (Fig. 7c) and engage the exhaust in the terminal. Slide the adaptor down over the spigot. Mark and drill the adaptor, using a 2mm bit, as shown in Fig. 7b. Secure the adaptor to the spigot using one of the screws supplied.
10. If it is necessary to shorten the 60Ø exhaust or any of the extensions, the excess material must be cut from the plain end of the pipe.
11. Determine the position of the 60Ø exhaust and mark on the wall a suitable position for the support bracket. If extensions are being used, a support bracket is supplied in each kit.
12. Drill the wall, and fit the bracket(s) using the plug and screw provided.
13. Mark and drill the 60Ø exhaust, using a 2mm bit, as shown in Fig. 7d. Complete the installation of the 60Ø exhaust, securing in the brackets.
14. Fit the 93° elbow/plume outlet and secure with the two remaining screws supplied. Ensure the plume outlet is at least 45° to the wall and that the 'peak' is uppermost (Fig. 7e).

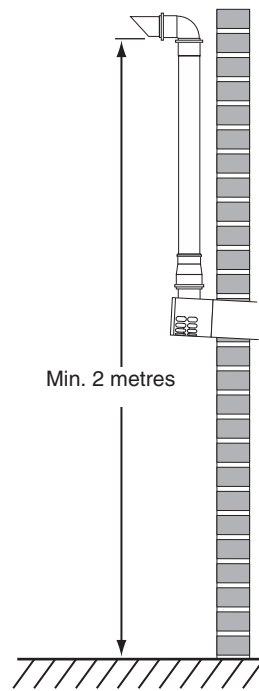

Fig. 7

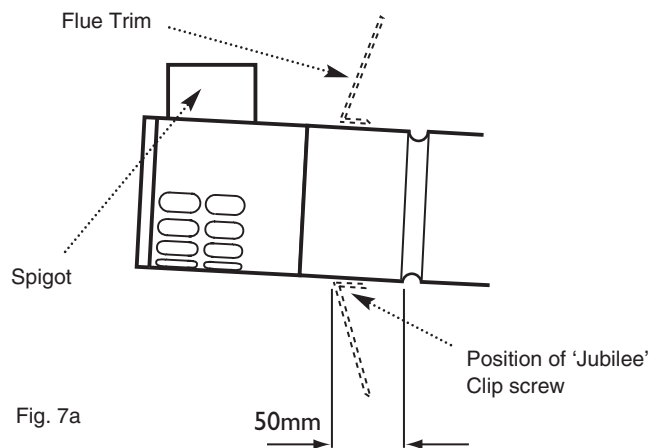

Fig. 7a

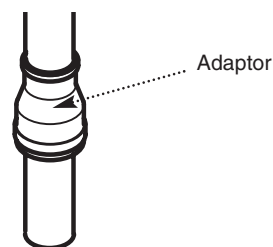

Fig. 7c

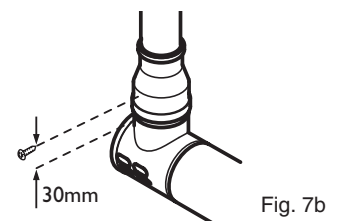
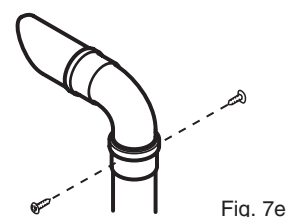
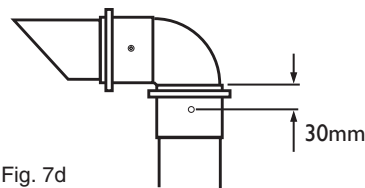

Fig. 7d



General Fitting Notes (cont.)

15. For aesthetic purposes it is permissible to route the 60Ø exhaust in an enclosed box, but the air inlet and plume outlet MUST remain in free air.

16. It is also possible to separate the plume outlet from the 93° elbow to allow the flue to be installed as shown in Fig. 7f.

17. To do this, first slacken the two screws retaining the plume outlet to the elbow, and remove the outlet (Fig. 7g). The elbow can now be used to connect the vertical to horizontal 60Ø exhaust (Fig. 7f). Retighten the screws in the elbow.

18. The outlet can now be fitted into the female end of an 60Ø extension piece. It must be secured using two of the screws supplied in the bag with the 'Jubilee' clip.

19. Mark the female end of the extension at 30mm as shown in two positions, directly opposite each other (Fig. 7h).

20. Using a suitable bit (e.g. 2mm), drill through the extension and outlet. Secure using two of the screws supplied.

21. The remaining screw must be used to secure the adaptor to the concentric terminal.

22. When the plume outlet is positioned under a balcony or other projection (Fig. 7j) it must protrude at least 200mm (it is not necessary to extend it further than this).

23. When under balconies or projections it is permissible to rotate the concentric flue length up to 70°, clockwise or anti-clockwise (Fig. 7k), if there is insufficient space to connect vertically.

24. This will allow the connection of the exhaust to the outlet spigot.

25. All other minimum & maximum dimensions must be adhered to, and the air inlet positioned such that it will not be subject to rain entry.

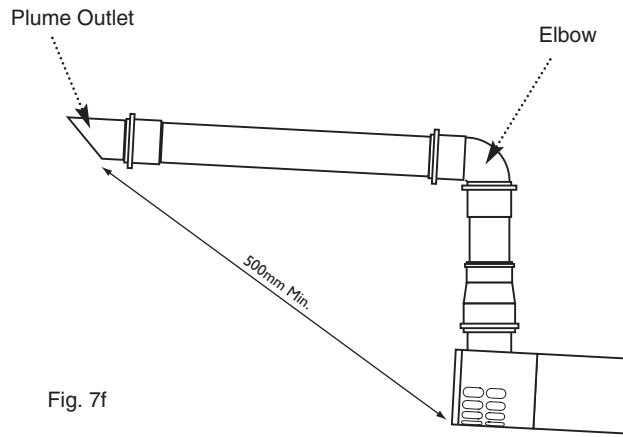

Fig. 7f

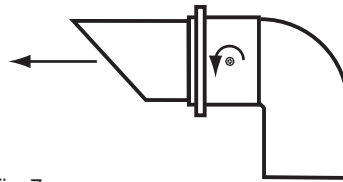

Fig. 7g

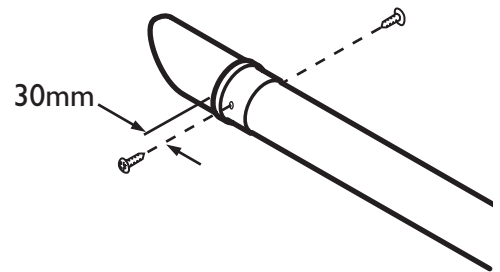

Fig. 7h

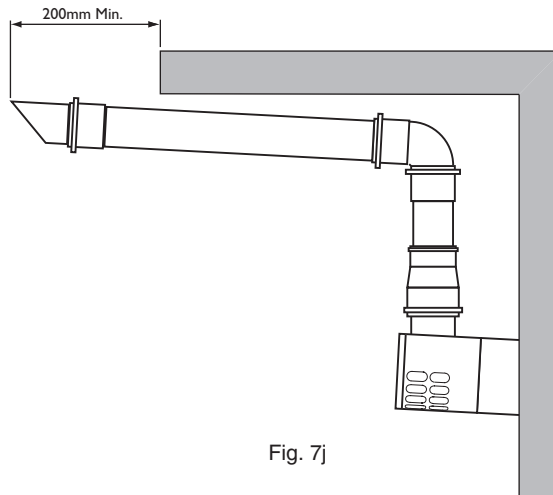

Fig. 7j

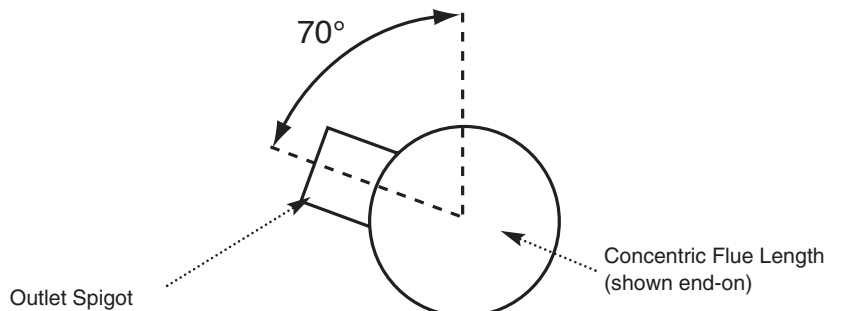

Fig. 7k

1.6 Water Supply

Mains Supply Requirements

It is essential that the mains supply pressure and available flow rate are capable of meeting demand for both hot and cold water. Promax Store is not recommended for unvented use where the dynamic mains pressure is below 1.0 bar.

Unless consistently high mains pressures are available, it is unlikely that a service pipe of less than 25 mm OD (Blue MDPE) will supply an adequate flow rate.

Plumbing Design

A combination inlet valve group is included with every Promax Store (packed in the "Accessories" box supplied with the Heat Engine). The mains water supply must be connected via the combination reducing valve and the cross fitting, in that order. Both components are clearly marked with the direction of flow (see Fig. 11 page 29).

The cold feed pipe to showers (and other mixer fittings needing balanced pressures) must be taken from the 22mm blanked outlet port of the combination reducing valve (or a tee between this and the cross fitting). The valve can be sited near where the water mains enters the dwelling, to assist with providing reduced pressure to all the system.

Cold water draw-offs that do not require a balanced supply e.g. hose-union or WC cistern, should be teed off upstream of the combination reducing valve.

A 22mm connection is provided from the hot water store. Smaller diameter pipework may be used locally for terminal fittings as part of a balanced design.

Thermostatic shower mixers are recommended to optimise performance; these must be suitable for use at mains pressure. Using flow restrictors will help prolong the showering time available from smaller capacity stores.

Use in Hard Water Areas

In the UK., water is drawn from diverse sources some of which have high levels of natural hardness. If not dealt with effectively, the scaling associated with hard waters can adversely affect hot water performance. As a general guide, if the temporary hardness exceeds 200 mg/l, then some form of water treatment device is required. The ultimate solution is an ion-exchange (salt regenerated) water softener. In addition to protecting the Promax heat exchanger against the effects of limescale, an ion-exchange softener offers users other benefits and should be specified with an appropriate flow rate capacity.

Water "conditioning" devices such as those which dose the incoming water with food grade polyphosphates can

be effective in reducing limescale but require correct siting and regular replenishment to remain operational. They should generally not be fitted where heat could impair their performance. Other types of device can inhibit scale formation but their effectiveness may vary. The manufacturers of any water conditioning device should be consulted regarding its suitability for the application and the particular water supply to the installation address.

Record the type of conditioner being used in "Benchmark" Commissioning Checklist.

Treatment of Water Circulating Systems

All recirculatory water systems will be subject to corrosion unless an appropriate water treatment is applied. This means that the efficiency of the system will deteriorate as corrosion sludge accumulates within the system, risking damage to pump and valves, boiler noise and circulation problems.

When fitting new systems flux will be evident within the system, which can lead to damage of system components.

All systems must be thoroughly drained and flushed out. Using, for example Betz-Dearborn Sentinel X300 or X400 or Fernox Superfloc Universal Cleanser. They should be used following the flushing agent manufacturer's instructions.

System additives - corrosion inhibitors and flushing agents/descalers should be suitable for aluminium and comply to BS7593 requirements, e.g. Betz-Dearborn Sentinel X100 and Fernox-Copal which should be used following the inhibitor manufacturer's instructions.

Failure to flush and add inhibitor to the system will invalidate the appliance warranty.

It is important to check the inhibitor concentration after installation, system modification and at every service in accordance with the manufacturer's instructions. (Test kits are available from inhibitor stockists.)

Sealed Primary Systems

This boiler must be installed into a sealed primary system. As a general guide systems of up to 7-9 radiators will operate satisfactorily with the 10 litre expansion vessel built into the boiler.

• Guidance on expansion vessel sizing

These notes explain how to calculate the total expansion vessel volume required, based on the size and the initial cold fill pressure of the system. If the required volume exceeds that of the vessel fitted to the boiler then an additional vessel should be installed, on the return connection from the heating system. The charge pressure of any additional vessel is assumed to be 1.0 bar, the same as the vessel fitted to the boiler.

If the initial cold fill pressure is 1.0 bar:
expansion vessel size = 0.11 x system volume

This fill pressure will allow the maximum expansion capacity, though any minor loss of water will result in a rapid pressure drop. An additional expansion vessel is only required if the total system volume exceeds 98 litres.

This includes the 4 litre primary circuit volume within the Promax HE Store boiler - thus radiator and pipework volume should not exceed 94 litres.

Pipework above boiler

Air vents must be fitted at the highest positions on flow and return pipes and at any point where air is likely to collect.

TRV's in System

An automatic bypass valve is built into the boiler to allow thermostatic radiator valves to be fitted. This can be switched into or out of circuit as required.

1.7 Discharge Pipework

It is a requirement of Building Regulation G3 that any discharge from an unvented system is conveyed to where it is visible, but will not cause danger to persons in or about the building. The tundish and discharge pipes should be fitted in accordance with the requirements and guidance notes of Building Regulation G3. The G3 Requirements and Guidance section 3.9 are reproduced in the following sections. Information Sheet No. 33 available from the British Board of Agreement gives further advice on discharge pipe installation. For discharge pipe arrangements not covered by G3 Guidance or BBA Info Sheet No.33 advice should be sought from either your local Building Control Officer or Potterton.

G3 Requirement "...there shall be precautions ... to ensure that the hot water discharged from safety devices is safely conveyed to where it is visible but will not cause danger to persons in or about the building."

G3 Guidance SECTION 3.9

The discharge pipe (D1) from the vessel up to and including the tundish is generally supplied by the manufacturer of the hot water storage system. Where otherwise, the installation should include the discharge pipe(s) (D1) from the safety device(s). In either case the tundish should be vertical, located in the same space as the unvented hot water storage system and be fitted as close as possible and within 500 mm of the safety device e.g. the temperature relief valve. **Note: The tundish is factory fitted during manufacture of the Promax HE Store.** The discharge pipe (D2) from the tundish should terminate in a safe place where there is no risk to persons in the vicinity of the discharge, preferably be of metal and:

a. be at least one pipe size larger than the nominal outlet size of the safety device unless its total equivalent hydraulic resistance exceeds that of a straight pipe 9m long i.e. discharge pipes between 9m and 18m equivalent resistance length should be at least two sizes larger than the nominal Outlet size of the safety device, between 18 and 27m at least 3 sizes larger, and so on. Bends must be taken into account in calculating the flow resistance. Refer to Fig. 8, Table 1 and the worked example.

An alternative approach for sizing discharge pipes would be to follow BS 6700:1987 Specification for design installation, testing and maintenance of services supplying water for domestic use within buildings and their curtilages. Appendix E. section E2 and table 21.

b. have a vertical section of pipe at least 300 mm long, below the tundish before any elbows or bends in the pipework.

c. be installed with a continuous fall.

d. have discharges visible at both the tundish and the final point of discharge, but where this is not possible or practical, there should be clear visibility at one or other of these locations. Examples of acceptable discharge arrangements are:

i. ideally below a fixed grating and above the water seal in a trapped gully.

ii. downward discharges at low level; i.e. up to 100mm above external surfaces such as car parks, hard standings, grassed areas etc. are acceptable providing that where children may play or otherwise come into contact with discharges a wire cage or similar guard is positioned to prevent contact, whilst maintaining visibility.

iii. discharges at high level; e.g. into a metal hopper and metal down pipe with the end of the discharge pipe clearly visible (tundish visible or not) or onto a roof capable of withstanding high temperature discharges of water and 3m from any plastic guttering system that would collect such discharges (tundish visible).

iv. where a single pipe serves a number of discharges, such as in blocks of flats, the number served should be limited to not more than 6 systems so that any installation discharging can be traced reasonably easily. The single common discharge pipe should be at least one pipe size larger than the largest individual discharge pipe (D2) to be connected. If unvented hot water storage systems are installed where discharges from safety devices may not be apparent i.e. in dwellings occupied

by blind, infirm or disabled people, consideration should be given to the installation of an electronically operated device to warn when discharge takes place.

Note: The discharge will consist of scalding water and steam. Asphalt, roofing felt and non-metallic rainwater goods may be damaged by such discharges.

Worked example of discharge pipe sizing

The example below is for a G1/2 temperature relief valve with a discharge pipe (D2) having 4 No. elbows and length of 7 m from the tundish to the point of discharge.

From Table 1:

Maximum resistance allowed for a straight length of 22mm copper discharge pipe (D2) from a G1/2 temperature relief valve is 9.0 m.

Subtract the resistance for 4 No. 22 mm elbows at 0.8m each = 3.2 m.

Therefore the permitted length equates to: 5.8 m.

5.8 m is less than the actual length of 7 m therefore calculate the next largest size.

Maximum resistance allowed for a straight length of 28 mm pipe (D2) from a G1/2 temperature relief valves equates to 18 m.

Subtract the resistance of 4 No. 28 mm elbows at 1.0 m each - 4.0 m.

Therefore the maximum permitted length equates to: 14 m.

As the actual length is 7 m, a 28 mm min. (D2) copper pipe will be satisfactory.

Warnings

- Under No circumstances should the factory fitted Temperature/Pressure Relief Valve be removed other than by Authorised Potterton personnel. To do so will invalidate any warranty or claim.
- The cold water Inlet Control Group must be fitted to the mains water supply to the Promax HE Store when it is operated as an unvented system.
- Control and safety valves MUST NOT be tampered with.
- The discharge pipe MUST NOT be blocked or used for any other purpose.
- The tundish must not be removed but can be sited outside the RH panel using the opening provided.
- Electrical components must not be sited near the tundish.

Valve outlet size	Minimum discharge pipe D1	Minimum discharge pipe D2 from tundish	Maximum resistance allowed, expressed as a length of straight pipe (i.e. no elbows or bends)	Resistance created by each elbow or bend
G1/2	15 mm	22 mm 28 mm 35 mm	up to 9 m up to 18 m up to 27 m	0.8 m 1.0 m 1.4 m
G3/4	22 mm	28 mm 35 mm 42 mm	up to 9 m up to 18 m up to 27 m	1.0 m 1.4 m 1.7 m
G1	28 mm	35 mm 42 mm 54 mm	up to 9 m up to 18 m up to 27 m	1.4 m 1.7 m 2.4 m

Table 1. Sizing of copper discharge pipe (D2) for common temperature relief valve outlet sizes. **Note:** shaded area is reproduced for completeness but does not apply to this boiler.

Typical Discharge Pipe Arrangement

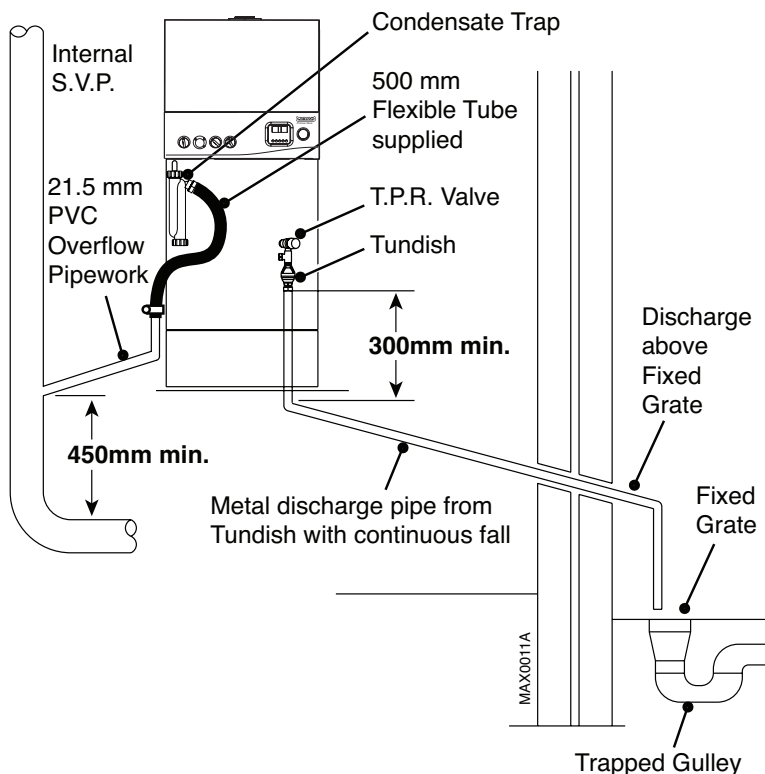

Fig. 8

2. Installation

2.1 Install the boiler

Before starting an installation, check that the correct flue kit and correct capacity cylinder have been supplied.

Important: When soldering plumbing fittings, do not allow flame from blowtorch to come into contact with the insulating foam or other non-metallic parts.

Guidance on where to locate the boiler is given in Sections 1.3 and 1.5. *In some instances it will be advantageous to pre-plumb pipework or to pre-fix terminal, air/flue pipes and duct.*

1. Remove top and front panels (see Fig. 1) and carefully set aside.
2. Determine boiler final position. The cutaway in the cylinder base allows pipework to be brought up from below floor level. Use the dimensions below or the **template on the reverse of the Installation Guide** to pre-drill any holes. Pipes must not obstruct service access to the immersion heater (if fitted) or to the condensate trap.
3. Move boiler into position. The need to move as Top and Bottom sections or as a complete assembly will depend on the individual installation. The Top has 4 downward facing dowel pins which provide accurate location on to the cylinder. Take care to avoid trapping hands and fingers during assembly.
4. **Apply sealant to cone faces** of both 22mm Union Nuts (see Fig. 10). Remove cardboard pipework support. Attach the 15mm x 90° branch pipe joining the two relief valves/tundish.

5. Release DHW temperature sensor and un-roll cable. Route cable behind cylinder pipes and **push sensor fully home (approx. 310mm - 12")** into the pocket in the cylinder.
6. Remove small knock-outs as required either side of casing for plumbing access. The handholds in the side panels can also be used. Further access holes allow the condensate to be routed via the LH panel and the DHW to be plumbed via the RH panel.

2.2 Connect the Flue System

1. Unless already fitted, install the flue system as shown in the Installation Instructions supplied with the flue kit.

2.3 Connect the Gas Supply

1. Ensure that the gas supply is isolated.
2. The gas connection to the boiler is 22 mm. Refer to Section 1.1 for information on the required gas supply. **Do not turn the gas supply on at this stage.**

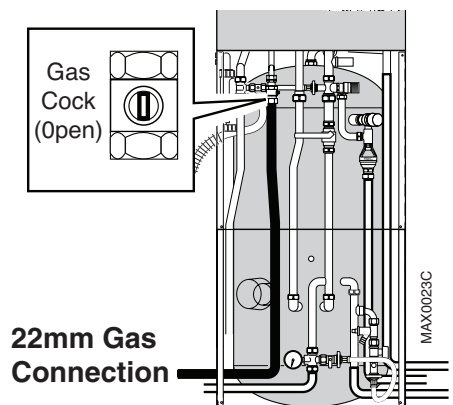

Fig. 9a

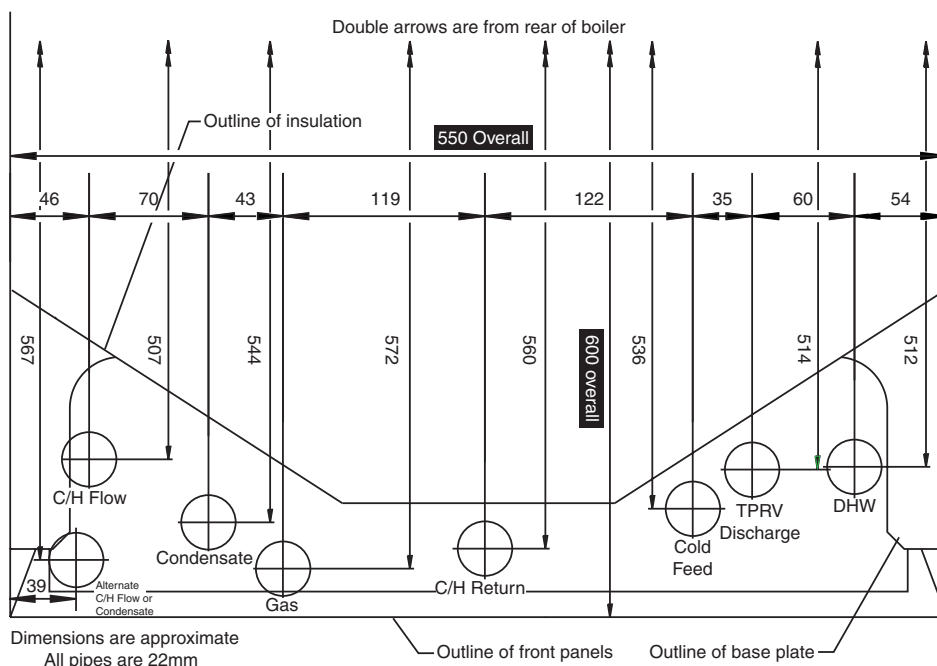

Fig. 9

Component & Connection Identification

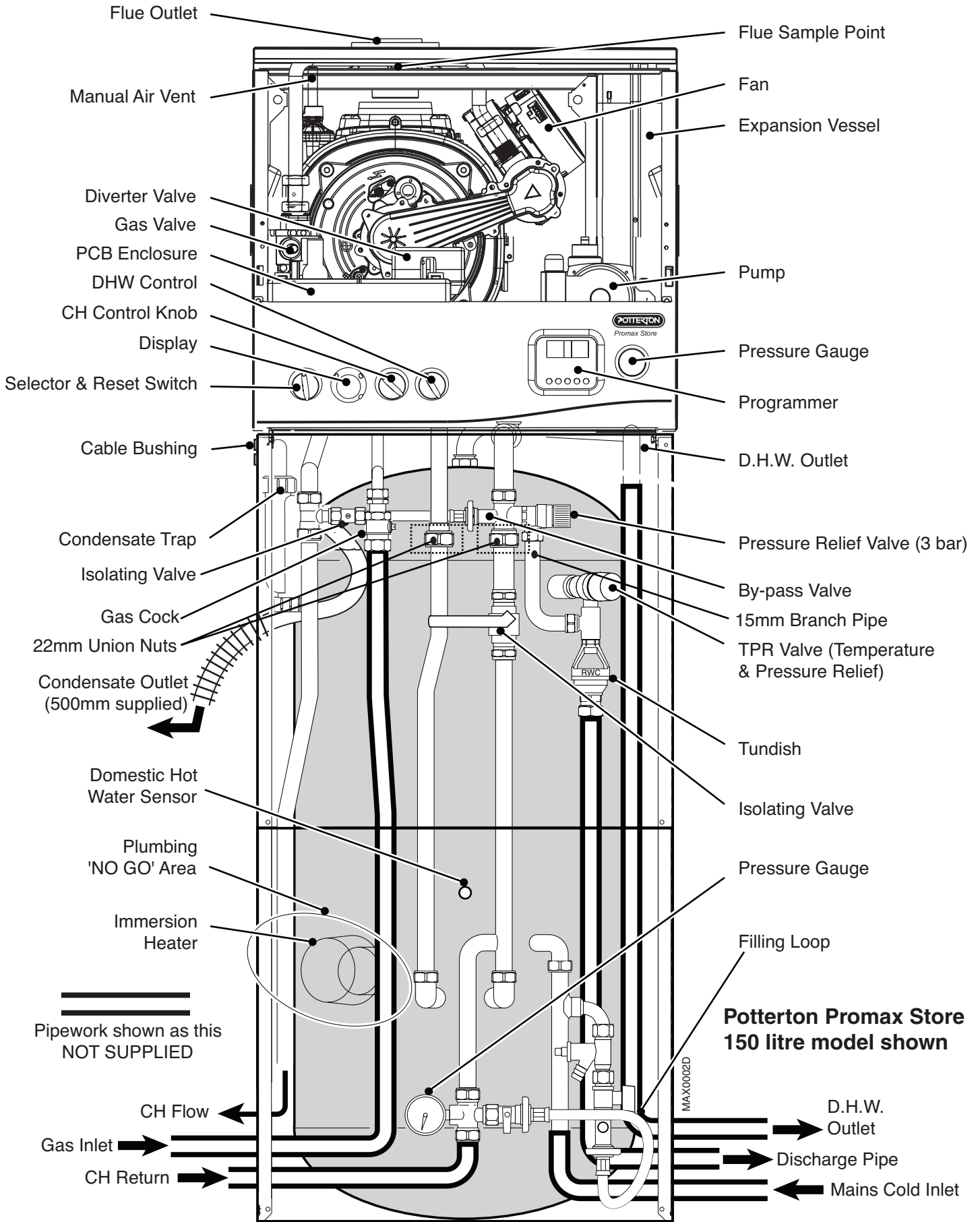

Fig. 10

2.4 Condensate Drain Pipe

Before fitting, fill the condensate trap with water.

Fit the steady bracket (with round hole) for the condensate trap to the lower pair of holes in the left hand cylinder side panel. Snap the C-shaped bracket into the groove in the condensate connector. Insert the condensate trap into the steady bracket and fit the C-shaped bracket to the upper pair of holes in the left hand cylinder side panel.

Ensure that the washer seal is in place as indicated and tighten the large nut.

The condensate pipe should be run in 21.5/22.0 mm diameter plastic material suitable for operation at 60° C. Solvent weld PVC overflow is recommended or a PP system can be used. Copper tube must not be used. Do not use push-fit plastic pipe.

Use the flexible pipe provided to connect to 21.5mm PVC pipe; alternatively a Marley or Plumb Center elbow can be used to direct the condensate pipe through the LH side panel (see Fig. 10a). When using the Osma PVC overflow system, a 3/4 -to-22mm adaptor No. 158 may be required.

Internal pipework should have a bore diameter no smaller than 14 mm.

External pipework should be kept to a minimum, and have a bore diameter no smaller than 32 mm.

Ideally the condensate pipe should be run internally to the house soil and vent stack or to a waste pipe. Alternatively, the condensate may be discharged into the rainwater system, or a purpose-built soakaway.

All connecting drainage pipework must have a fall of at least 50 mm per metre run. It is recommended that the pipe is insulated if run externally to minimise the effects of freezing.

NOTE: Connection of a condensate pipe to a drain may be subject to local building regulations.

Manual Air Vent

Using the manual air vent, **thoroughly vent air from top of the heat exchanger** when filling the system to save time during the boiler commissioning. **Note:** 1/4" dia. manometer tube fits the manual vent.

Central Heating Pump & System By-pass

The central heating pump is factory fitted and an automatic system by-pass is provided. The boiler can be used in systems controlled by thermostatic radiator valves (TRVs) but it is essential that the by-pass isolating valve is fully open.

The circulating pressure and flowrate available for the central heating system is shown opposite with the by-pass in circuit.

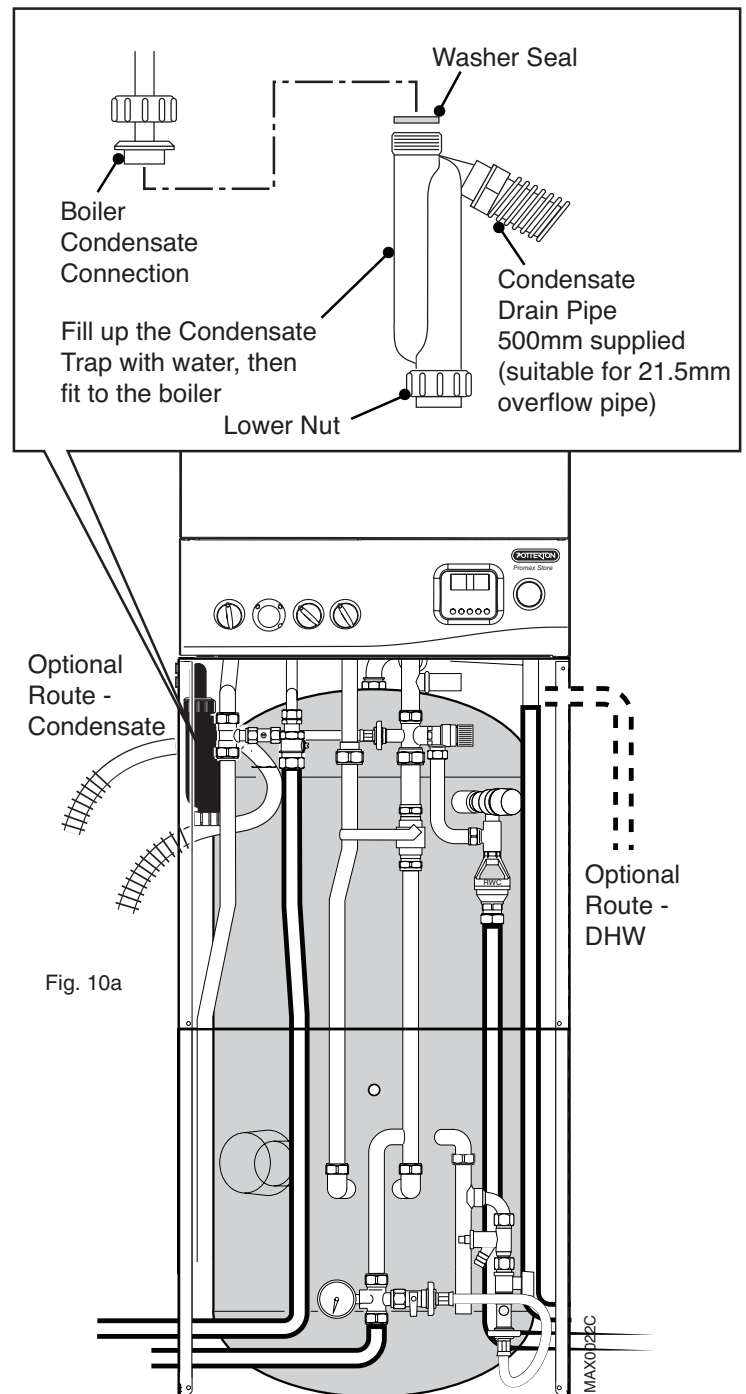
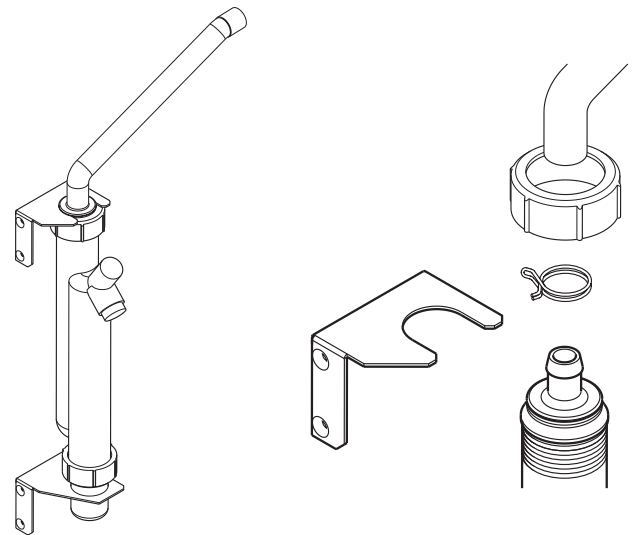

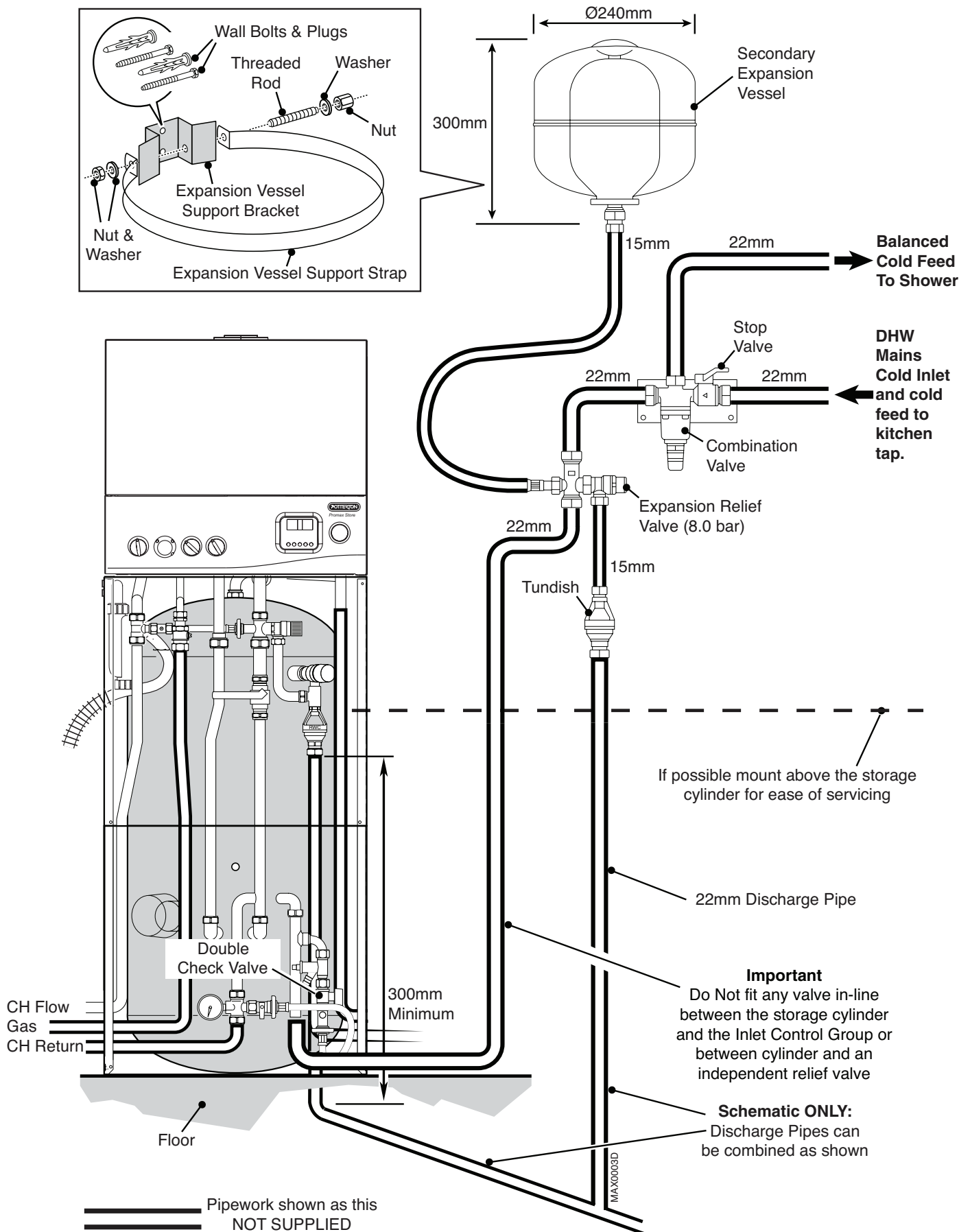
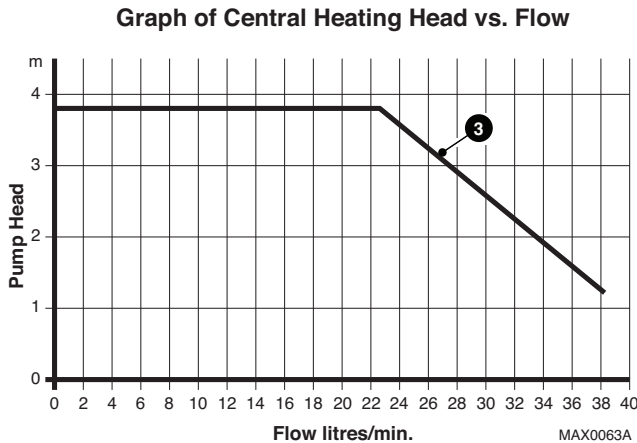

Fig. 11



Secondary Circulation

A pumped secondary circuit, if required, can be connected by teeing into the 22 mm DHW Outlet pipe and the 22 mm Cold Inlet pipe. **Note:** This is not recommended for models having a secondary store of less than 150 litres.

A single check valve (spring loaded type) should be fitted in the return from the secondary circuit. All component parts of a secondary circuit must be suitable for operation at temperatures up to 65 °C and pressures up to 8 bar.

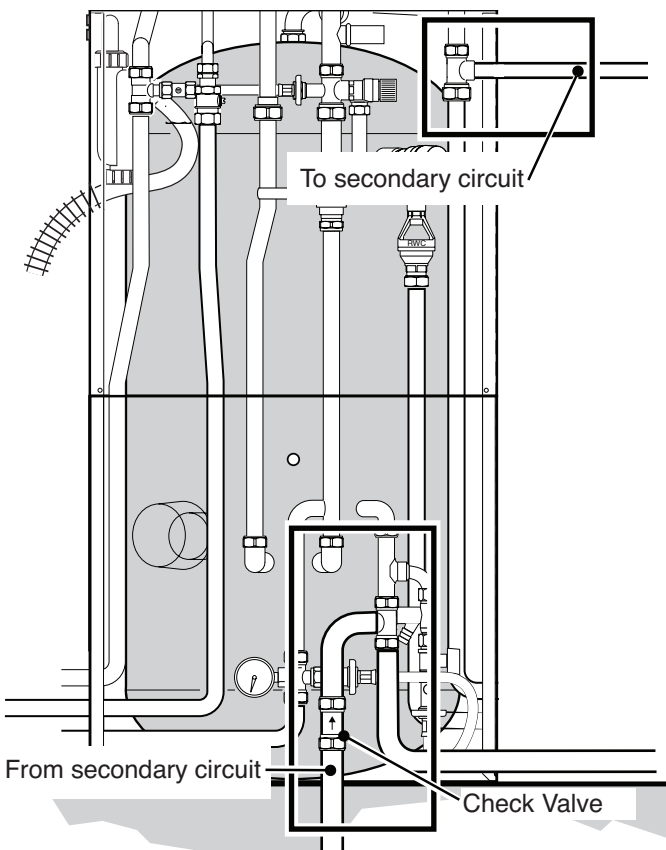

Fig. 12

2.5 Connect the Water System

Read and observe recommendations in Section 1.6 and see Fig. 11.

Secure the combination reducing valve - a wall bracket is provided in the accessory pack. 22mm copper tube is recommended for both the inlet and outlet connections. A 22mm balanced pressure outlet is built-in to this valve for supplying showers etc. It can be sited away from the boiler e.g. where the water mains enters the dwelling, to assist with providing reduced pressure to all the system.

Position the cross fitting c/w with expansion relief valve downstream of the reducing valve-see Fig. 11. Ensure the flow direction is correct - arrows indicate the direction of flow. Connect the tundish within 50cm of the relief valve. NB The valve can be rotated to give the best pipe run to the tundish.

Select a location for the expansion vessel within reach of the 1m flexible connector and fix the expansion vessel using the bracket provided. Avoid sharp bends or “kinks” in the flexible connector and ensure there is service access to the checking/charging point.

Future servicing operations will be simplified if the cross fitting/relief valve and the expansion vessel can be sited above the DHW store as indicated in Fig. 11.

CH System Connections

The flow connection is on the LH side of the unit. The 22mm flow pipe supplied with the cylinder provides clearance for future maintenance of the immersion heater. Ensure this pipe is pushed fully home into the “Tectite” joint. The return connection is low down at the front centre.

Pressure Relief Valve (Primary)

A pressure relief valve set at 3.0 bar is fitted to the Heat Engine’s primary circuit. Trim the supplied 15mm branch pipe to length before fitting - See Fig. 10.

2.6 Connect the Power Supply

WARNING – THIS BOILER MUST BE EARTHED

Wiring must comply with the current IEE Wiring Regulations. The supply cable must be 3-core 0.75sq. mm (24/0.2 mm) to BS6500 Table 16. The supply must be of 230V – 50Hz. A 3A-fused double pole-isolating switch may be used, having a minimum contact separation of 3 mm in both poles, providing it serves only the boiler and its system controls. Alternatively a 3A 3 pin fused plug may be used.

Making The Electrical Connections

To connect the mains input cable proceed as follows:-

1. Remove all the outer panels.
2. Completely undo the screws securing the fascia panel and hinge it down.
3. Remove the control box cover securing screws. Disengage the barbs on the control box from the cover. Remove the cover.
4. Insert the cable through one of the grommets at the top of the LH cylinder panel and route it to the terminal block.
5. Slacken the screws in the terminal block, connect the input cable, and tighten the screws.

NOTE: Both the Live and Neutral connections are fused.

6. If a room thermostat is to be connected it can be done at this point. Run the input cable from the thermostat through the second cable grommet in the cylinder side panel. Refer to the instructions supplied with the control.

IMPORTANT: The room thermostat **MUST** be suitable for 230V switching.

7. Remove the link between terminals 1 & 2. The 230V supply at terminal 1 can be connected to the thermostat. The switched output from the thermostat must be connected to terminal 2. If the room thermostat being used incorporates an anticipator it **MUST** be wired as shown in the diagram.

8. Ensure that both mains input and, where fitted, external control input cables have sufficient slack to allow the control box to drop down.

9. The boiler is fitted with a programmer that is powered up when the selector switch is in the (☀️) combined heating/hot water, or (🔥) hot water only positions. Although unpowered when the selector knob is in the "0" position, operating times are retained in the programmer memory. Full details of how to set up and use the programmer are in the User's Instructions.

10. An external frost 'stat, if required, must be wired in parallel with the room thermostat but will only be effective when the programmer central heating channel is set to the 24HR operating position. **Ensure that the user is aware of this limitation.**

Preliminary Electrical Checks

1. Prior to commissioning the boiler preliminary electrical system checks should be carried out.
2. These should be performed using a suitable meter, and include checks for Earth Continuity, Resistance to Earth, Short Circuit and Polarity.

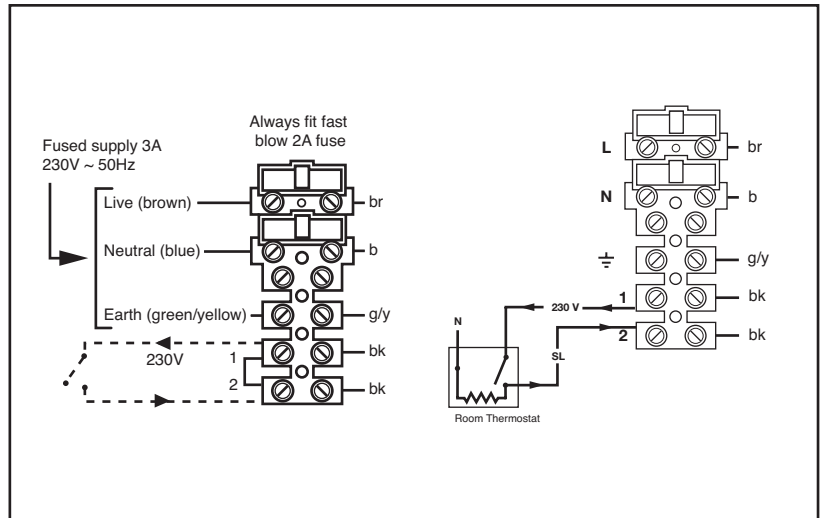
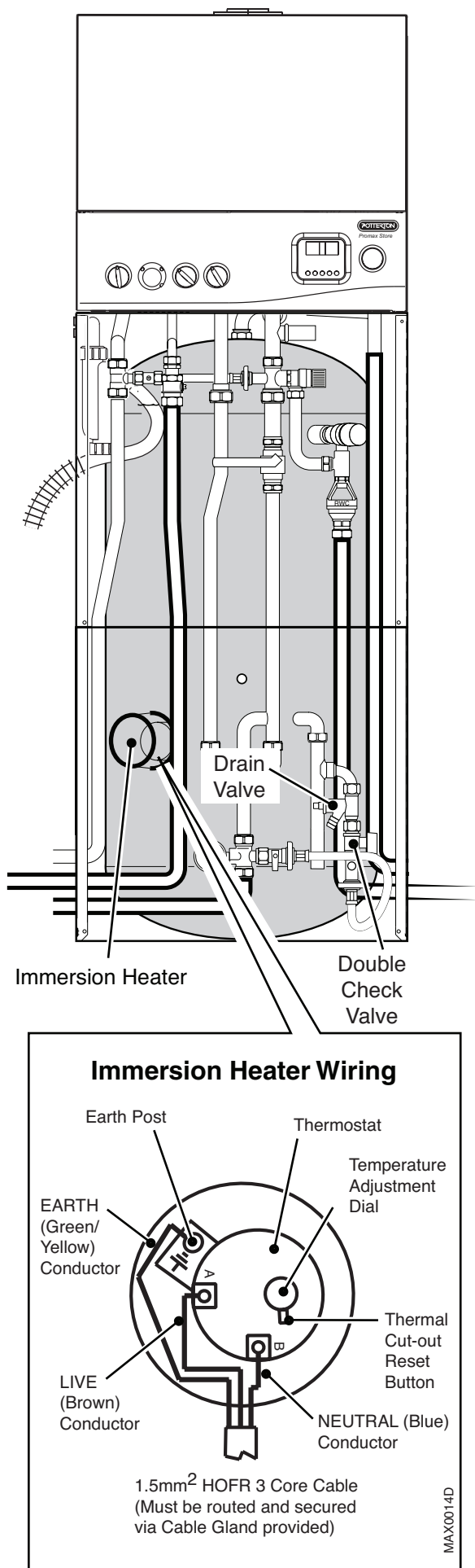

Fig. 13



2.7 Immersion Heater

The immersion heater is rated 3kW at 240V and must be wired to a separate, suitably rated electrical supply. THERE MUST BE NO INTERCONNECTION WITH THE WIRING TO THE BOILER.

WARNING: THE IMMERSION HEATER MUST BE EARTHED.

It should be installed in accordance with the current IEE Wiring Regulations and be wired through a double pole isolating switch or suitable controller with a contact separation of at least 3mm in both poles. The immersion heater must be fully immersed and not switched on dry.

2.7.1 Wiring the immersion heater

The immersion heater must be wired with 85°C rubber insulated HOFER sheathed flexible cable with a conductor cross sectional area of 1.5mm² complying with BS6141 Table 8.

Remove the immersion heater cover by removing the securing nut and pulling the cap away from the cylinder. The Live (Brown) conductor should be connected directly to the thermostat terminal marked A. The Neutral (Blue) conductor should be connected directly to the thermostat terminal marked B. The earth conductor should be connected to the threaded post on the bracket marked \perp .

The supply cable outer sheath must be routed through the cable gland supplied and secured by tightening the gland after fitting. Ensure the connections to the immersion heater are not under any strain before tightening.

Re-fit the protective cover over the immersion heater assembly and secure by the nut previously removed tightened onto the end of the threaded post where it emerges through the cover.

2.7.2 Operation

The immersion heater is controlled by the rod type thermostat supplied. DO NOT USE ANY OTHER TYPE OF THERMOSTAT.

A temperature setting of 60 to 65°C is recommended and is factory preset (between position 4 and 5 on the adjustment dial). This should be reduced to 55°C (position 3 on dial) in hard water areas.

The thermostat incorporates a thermal cut-out which cuts the power to the immersion heater in an overheat situation. Should this operate it can be manually reset by pressing the red button to the side of the temperature adjustment dial.

Note: Investigate the cause of over-heating and rectify before resetting.

Fig. 14

2.8 How to Drain Hot Water Storage Cylinder

Isolate mains water supply at stop valve on Inlet Control Group and close /turn valve (handle at 90° to valve body) on double check valve - see Fig. 14.

Fit a hosepipe to the tail of the drain valve (secure with “Jubilee” clip), and run open end to a low level where water can be safely drained.

Open nearest tap(s) fully (to allow air to enter cylinder) before opening the drain valve above hose. **Note:** The lower the open end of the hose, the faster will be the draining effect.

When refilling: check that the secondary expansion vessel pre-charge pressure is between 2.5 to 2.7 bar and allow water to flow freely before closing tap(s).

2.9 Control Panel, Displays & Diagnostics

The boiler control fitted to Promax Store has been designed to provide safe, reliable and economical operation of the boiler - see Fig. 15 for a guide to the control panel.

Fault finding, during both commissioning and subsequent maintenance is much simplified by the clear display of lockout and error codes which appear in the ‘Status/Error Code Display’. What the codes represent and the remedial actions required are explained on Page 50.

Full details of how to set up and use the programmer are in the User’s Instructions.

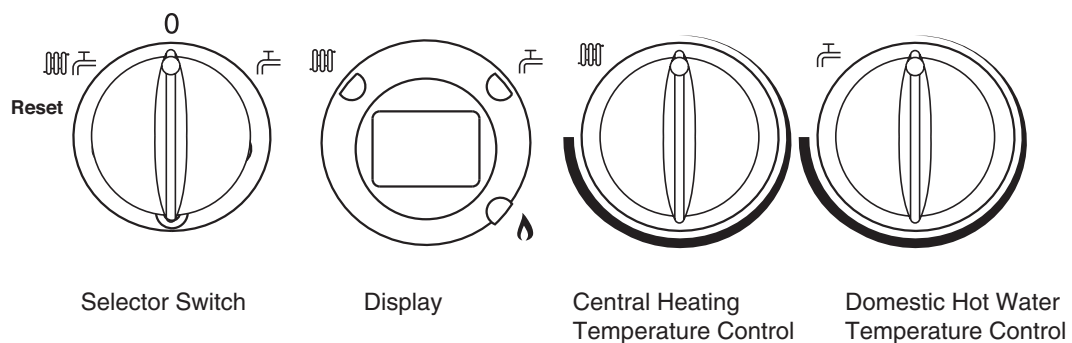

Fig. 15

3. Commissioning

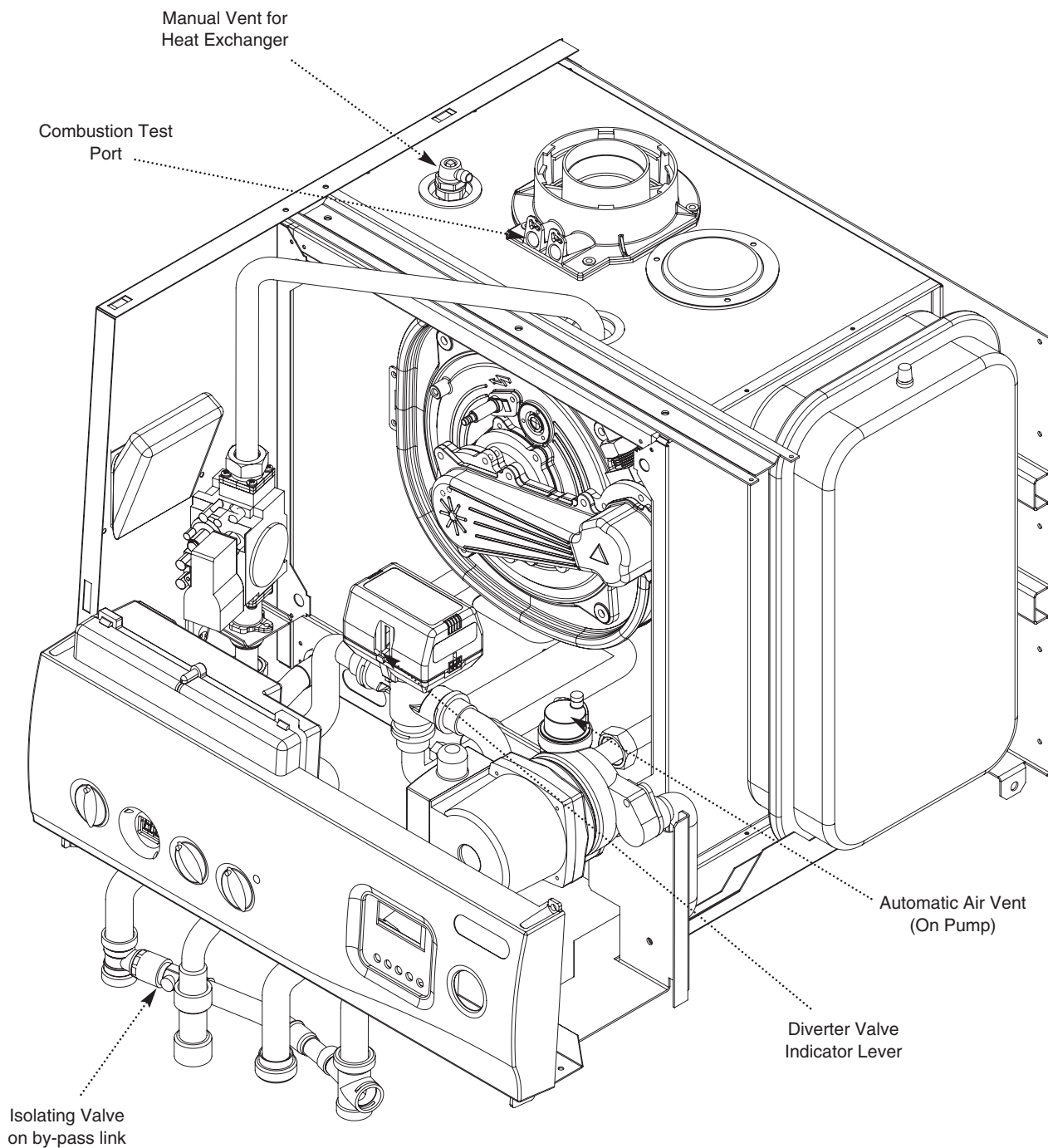

Fig. 16

Important

The commissioning and boiler adjustment must only be carried out by a suitably qualified person. Potterton offer this service on a chargeable basis.

Important

When checking for gas soundness open all windows and doors in the room. Extinguish all naked lights, cigarettes, pipes, etc.

3.1 Commission the Boiler

Automatic Air Vent: This is built into the pump. Leave the cap open during and after commissioning.

Manual Air Vent: This must be used to remove as much air as possible before firing the burner.

Warning: Do not attempt to start this boiler unless the primary circuit has been filled with water.

Preliminary Electrical System Checks

These checks must be carried out prior to attempting to start the boiler. They are, Earth Continuity, Short Circuit, Polarity & Resistance to Earth.

Flush the System

The system must be flushed in accordance with BS7593 and the flushing agent manufacturer's instructions. Further guidance can be obtained from BS5449 Section 5.

Gas Soundness

Purge and test for soundness in accordance with BS6891 or I.S. 813. The inlet pressure test point of the gas valve is indicated opposite. The appliance gas cock operation is shown in Fig. 9A page 26.

Unvented Domestic Hot Water System

1. Open one or more hot water taps.
2. Turn on mains water supply and observe air free water issuing from tap(s)
3. Close tap(s) and check mains water pipework for leaks
4. Check that all factory-made plumbing connections are tight and leak free (and have not loosened in transit).
5. Manually operate both the Temperature & Pressure Relief Valve and the secondary pressure relief valve and ensure that the discharge from these valves emerges safely. Close them again with a "snap" action.

Guideline times for the initial heat-up and recovery for a nominal 50 °C temperature rise (e.g. 15 °C - 65 °C) within the store are:

Unit	Heat-up	Recovery*
90 Litre	18 min.	15 min.
115 Litre	22 min.	18 min.
150 Litre	30 min.	23 min.

* From previous draw-off of 70% of volume.

Sealed Primary System

1. Ensure that gas supply is turned OFF at the gas cock.
2. Leave the boiler switched OFF at the selector switch but turn both the CH and DHW control knobs clockwise.
3. Move the indicator lever on the diverter valve head to the mid position and push in so that it "latches".
4. Check that the isolating valve on the by-pass link is OPEN (slot in-line with body).
5. Attach a length of hose to the outlet of the manual vent (1/4" manometer tube is suitable). Open the vent using a radiator key.
6. Open the automatic air vent cap (above the pump) by one turn. Check that filling loop is connected and supplied with water.
7. Open both valves on the filling loop and fill system with water. Allow water to flow from the manual vent until air is no longer discharged.
8. Turn the (LH) selector switch clockwise to the DHW position and use the HW/ENTER button on the programmer to select hot water on ALL DAY or 24HR
NOTE: Full details of how to set up and use the programmer are in the User's Instructions.
9. The pump and diverter valve should now operate allowing more air to be expelled. (Free the pump spindle if it appears to be sticking).
10. The boiler control will go to lockout after about a minute. Close the manual vent. Reset using the selector knob, turn the gas ON and allow the boiler to start heating the cylinder contents.
11. After approx. 5 minutes, central heating can be selected by using the selector switch and programmer.
12. If a fault is suspected, consult the list of Error Codes on page 42.

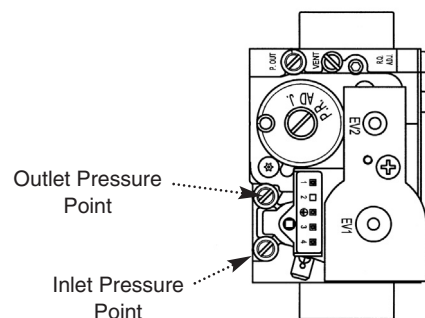

Commissioning Checks

1. The gas valve is factory set and the burner pressure changes as the fan modulates when demand on the boiler alters. There are two important gas rates that relate to a corresponding burner pressure that can be checked as verification during a gas rate check.

	Burner Pressure (mb)	Gas Rate (m ³ /hr)	CO (ppm)	CO ² (%)
Min Gas Rate	0.6 - 0.8	0.7 - 0.74	2 - 30	8.4 - 8.8
Max Gas Rate	6.8 - 7.2	2.48 - 2.74	30 - 80	8.7 - 9.2

2. If necessary the gas rate may be checked after running the boiler for 10 minutes with any other appliances and pilot lights turned off.

3. Ensure that the integral programmer and any external controls are calling for heat, and the selector switch is in the central heating and hot water position. The current boiler temperature is shown on the display.

4. To check the gas rate it is necessary to set the boiler to 'Calibration Mode'.

To carry out this operation

5. Turn both temperature control knobs fully anticlockwise, then quickly turn the DHW temperature knob 1/4 turn clockwise twice and back fully anticlockwise.

6. The display will now alternate between 'SF' and the current boiler temperature and both green LEDs will flash.

7. Turn CH temperature control knob fully clockwise. As the knob is turned the display will change from '0' to '00' indicating maximum rate, then revert to 'P' alternating with the current boiler temperature.

8. A gas rate measurement may now be made. Approximate values are:-

Max 2.61 m³/hr Min 0.74 m³/hr

9. The 'Calibration Function' is active for 20 minutes unless the maximum CH temperature is exceeded.

10. The function can be disabled at any time by turning the DHW temperature knob.

Central Heating System

1. Press programmer CH button to select heating (indicated by red neon).
2. Check that any connected room thermostat is calling for heat.
3. Note that when HW is selected the 3-way diverter valve does not allow circulation to the CH circuit until the storage cylinder contents have reached the selected temperature. After filling with cold water, this will normally take between 20 to 25 minutes.
4. With flow to the CH circuit, bleed every radiator and the pipework high points until all air or air/water mix has been removed.

N.B. Leave the cap on the auto air vent (above the pump) partially unscrewed so that the vent remains operational - note that the burner control goes to safety shut-down if the system pressure drops below 0.5 bar.

IMPORTANT: Do not vent the boiler with the burner running or damage to the heat exchanger may result.

5. Wait until the central heating circuit has reached its normal temperature of approx. 80 °C before balancing the radiators in the usual way to achieve a temperature drop of 10 °C.
6. Allow system to reach full temperature (all radiators at working temp.) and note "hot system" pressure. Switch boiler off, drain and flush the system.
7. Refill (using a suitable inhibitor) and remove all air and air/water mix. Check the relief valve is not "letting" by observing pipe outlet for several minutes. ("Letting" is usually due to debris on valve seat. Snapping the valve open-shut a few times will normally cure this).
8. Check that the system final pressure equals "hot system" pressure as noted in 7. above. Adjust if necessary.
9. Set the room thermostat or programmer according to the manufacturer's instructions.
10. Disconnect filling loop flexible hose and leave in a secure place for householder.

Domestic Hot Water System

1. With the cylinder fully heated, check DHW output temperature is approximately 45 to 65 °C (as selected) using nearest tap and a flow rate of approximately 5 l/min. Record inlet and outlet temperatures in Benchmark Checklist.
2. Measure hot water flow rate at bath tap (fully open) and record in Benchmark Checklist.
3. Refit outer covers in reverse order.

3.2 Hand Over to the User

1. Explain the boiler controls
2. Give guidance if the system is to be shut down for long periods when freezing is possible
3. Advise the User that for continued efficient and safe operation of the boiler it is important that annual servicing is carried out.
4. Explain how to re-start boiler if red neon indicates lockout.
5. Hand over the User's Instructions.
6. Carefully read and complete all sections of the Benchmark Commissioning Checklist at the rear of this publication that are relevant to the appliance and installation. These details will be required in the event of any warranty work. The publication must be handed to the user for safe keeping and each subsequent regular service visit recorded. For IE, it is necessary to complete a "Declaration of Conformity" to indicate compliance to I.S. 813. An example of this is given in I.S. 813 "Domestic Gas Installations". This is in addition to the Benchmark Commissioning Checklist.

4. Service & Replacement of Parts

To ensure safe, efficient operation of the boiler, it is necessary to carry out routine servicing at regular intervals. The frequency of servicing will depend upon the particular installation conditions and the use to which the boiler is put.

Important: Before commencing any servicing or exchange of components, always turn off the gas supply and isolate the electricity supplies (i.e. to boiler and immersion heater).

Annual servicing is recommended. After completing any service work always test for gas soundness and **Remember to fill in the Benchmark Checklist.**

To gain access to the boiler for servicing, remove front panel and top cover as described in Section 4.1.

Annually

Important: Any 'O' rings, seals, gaskets or washers disturbed during service or replacement of parts must be visually inspected and replaced if worn or damaged.

1. Remove outer and inner top covers to gain access to heat exchanger etc. Inspect components within compartment, checking that joints are dry etc.
2. Remove the heat exchanger door complete with burner, see Section 4.9. Inspect the burner, combustion chamber and heat exchanger, carefully clean using a vacuum cleaner. DO NOT separate the burner from the heat exchanger door. Inspect the electrode condition and check gap which should be 4.5 - 5.5mm.
3. Withdraw the ionisation probe, clean with wire wool or similar abrasive, replace if necessary. Re-fit heat exchanger door.
4. Partially open vent on top of heat exchanger and release any trapped air. Check that the cap on the auto air vent (on top of pump) is partially unscrewed.
5. Draw hot water from a bath tap if necessary to cause burner to light. Check ignition is smooth and visually inspect flame. Continue to draw water until maximum fan speed is attained. Check combustion, see 'Combustion Testing'.

6. Turn off the mains water supply at the Inlet Control Group and release system pressure by opening a hot tap. Using hexagon key provided, remove the pressure reducing cartridge from the Inlet Control Group. Clean the cartridge and strainer in running cold water. Re-fit the cartridge ensuring that the strainer is correctly located.

7. With no water pressure in the system, check and if necessary adjust the secondary expansion vessel pressure to approx. 2.5 to 2.8 bar (36 to 40 psi).
NOTE: Vessel pressure can not be accurately set with water pressure in system.

8. Restore pressure to DHW system. Manually operate, in turn, the expansion relief valve (part of Inlet Control Group) and the temperature & pressure relief valve (Fig. 10). Check that the discharge route(s) is unobstructed and that water flows freely to a safe, visible location. Check that both valves close correctly.

9. Release CH system pressure via relief valve and check primary expansion vessel pre-charge pressure is between 1.0 to 1.2 bar. Adjust if required and top up system to same pressure.

10. Check for gas soundness and re-assemble in reverse order.

11. Clean condensate trap by removing lower nut (see section 2.4 Fig. 10a).

Combustion Testing

A combustion analysis test point is provided on the flue outlet (just above heat exchanger). The test point is sealed by a special screw/'O' ring assembly. For a correctly installed boiler typical values to be expected are:

CO <80 ppm CO₂ <9.2 % at maximum input (**Hot condition after 10 minutes**)

Levels significantly above these should be investigated and may indicate a defective component or faulty installation. Ensure the test point is FULLY GAS TIGHT. Do not substitute any other screw for the special Promax Part No. 5114700.

4.1 General Access

WARNING: Before attempting to remove any component from the boiler first disconnect the mains electricity supply by removing the plug from the wall socket or by switching off the boiler at the external isolating switch.

IMPORTANT: After removal or replacement of any gas carrying component a test for gas soundness must be made and functional check of the controls carried out.

IMPORTANT: Any 'O' rings, seals, gaskets or washers disturbed during replacement of parts must be visually inspected and replaced if worn or damaged.

Re-assemble all parts in reverse order.

1. Follow stages 1 - 3 (opposite) to remove the outer panels.

Internal Access

2. Remove the screws securing the top engine box cover and lift the cover away from the boiler.
3. Remove the screws securing the air box cover and lift the cover away from the boiler.

4.2 Automatic Air Vent

Re-assemble all parts in reverse order.

1. Perform 4.1 General Access and drain down locally as described in 4.3
2. Pull away the securing clip and lift out the air vent parts as shown.

General Access

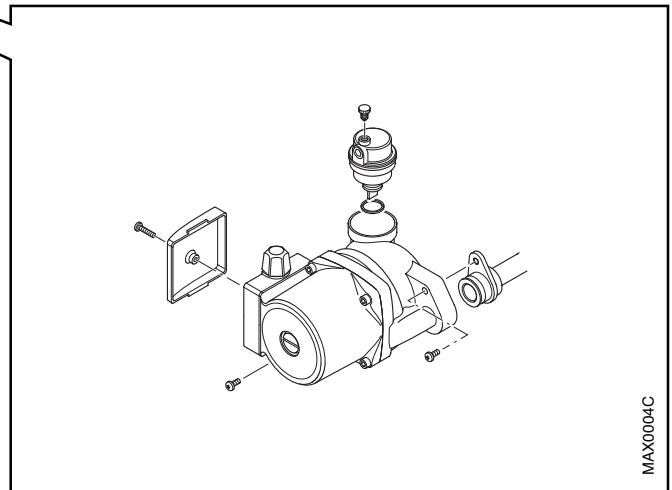
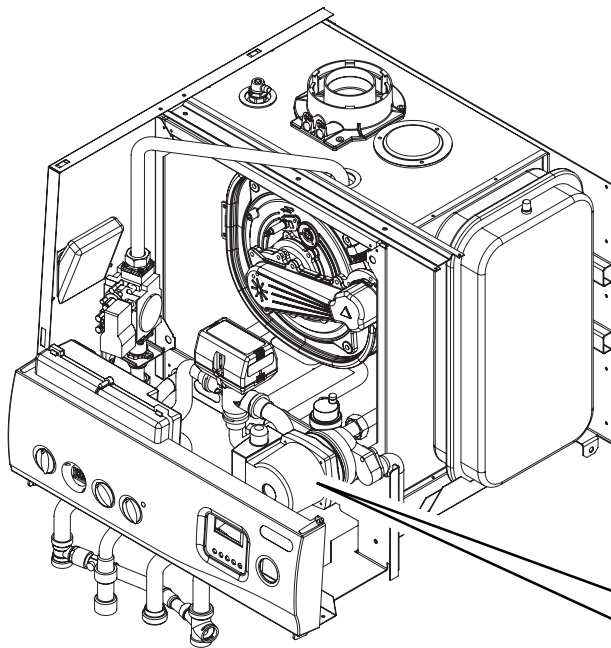
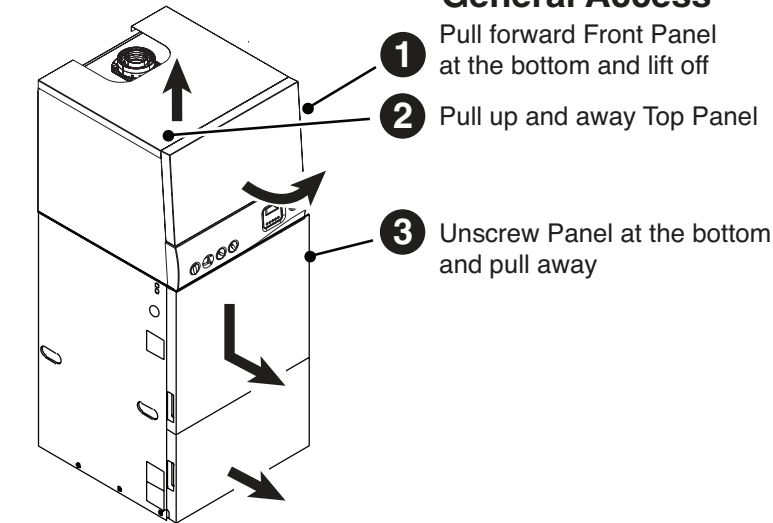

Fig. 17

4.3 Expansion Vessel, Pump & Pressure Switch

Re-assemble all parts in reverse order.

1. Check that the cap on the auto air vent is open. Turn the 3 isolating valves OFF and locally drain the boilers' circuit by opening the primary pressure relief valve.
2. Disconnect the flexible pipe at the union below the pump.
3. Pull the expansion vessel forward and 'spring' the RH side panel slightly to enable the vessel to be removed.
4. Check the pre-charge pressure of the replacement vessel is between 1.0 and 1.2 bar before fitting.
5. Reassemble in reverse order.

Pump - Head Only

1. Locally drain the boiler circuit as above and remove the socket head screws securing the pump head to the body and draw the head away.
2. Detach the pump cable.
3. A standard replacement Grundfos 15-60 head can now be fitted. Connect the pump wiring to the new head.
4. Reassemble in reverse order.

Pump - Complete

1. Drain the primary circuit.
2. Undo the two screws securing the body to the pipe fittings and draw the pump forwards.
3. Detach the pump cable.
4. Connect the wiring cable to the new pump. Examine the 'O' ring seals on the pipe fittings, replacing if necessary.

IMPORTANT: Leave the cap on the auto air vent partially unscrewed so that the vent remains operational.

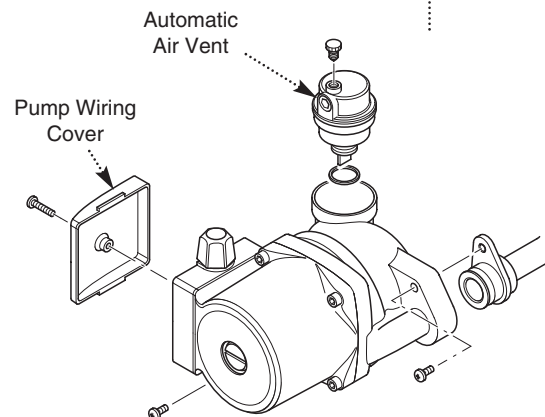
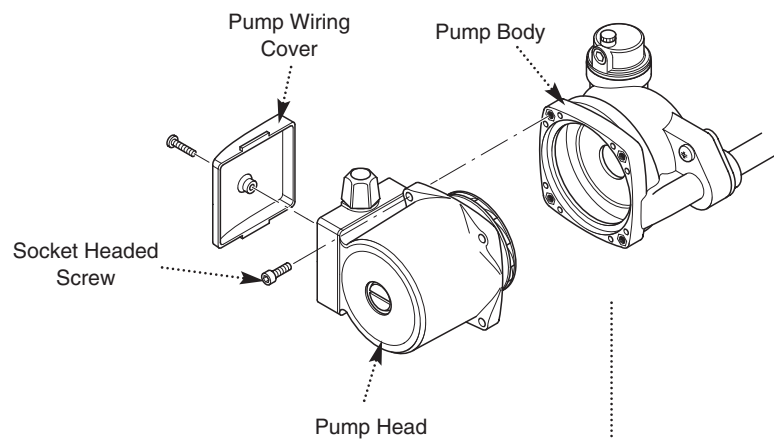
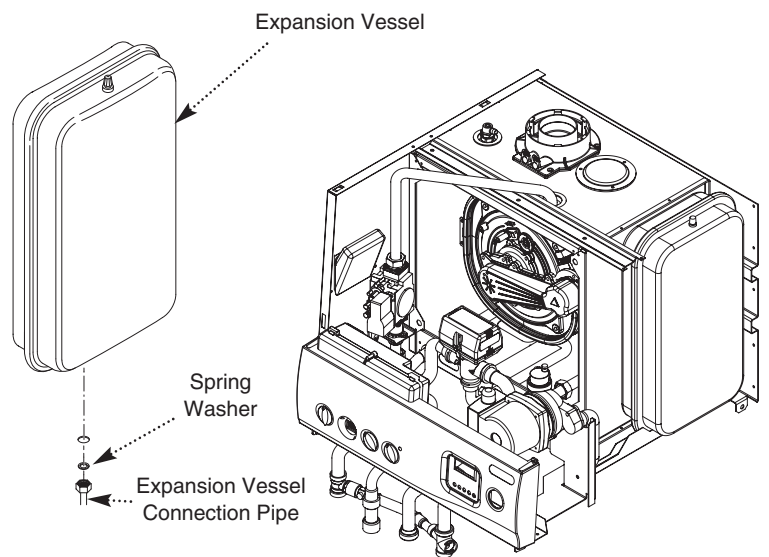

Fig. 18

4.4 Pressure Sensor/PRV

Re-assemble all parts in reverse order.

1. Perform 4.1 General Access.
2. Isolate three valves as shown and open the cap on the auto air vent.
3. Release pressure by opening the pressure relief valve.
4. **Primary Pressure Switch**
Disconnect the electrical connector and unscrew the switch.
4. **Pressure Relief Valve (PRV)**
Release union nut below the sensor body, remove securing clip and pull valve out from assembly.
4. **By-pass Valve**
This valve is part of the complete 'cross' unit and cannot be replaced separately. Remove the pressure relief valve as shown above then release the "Techtite" unions and remove the 'cross' unit.

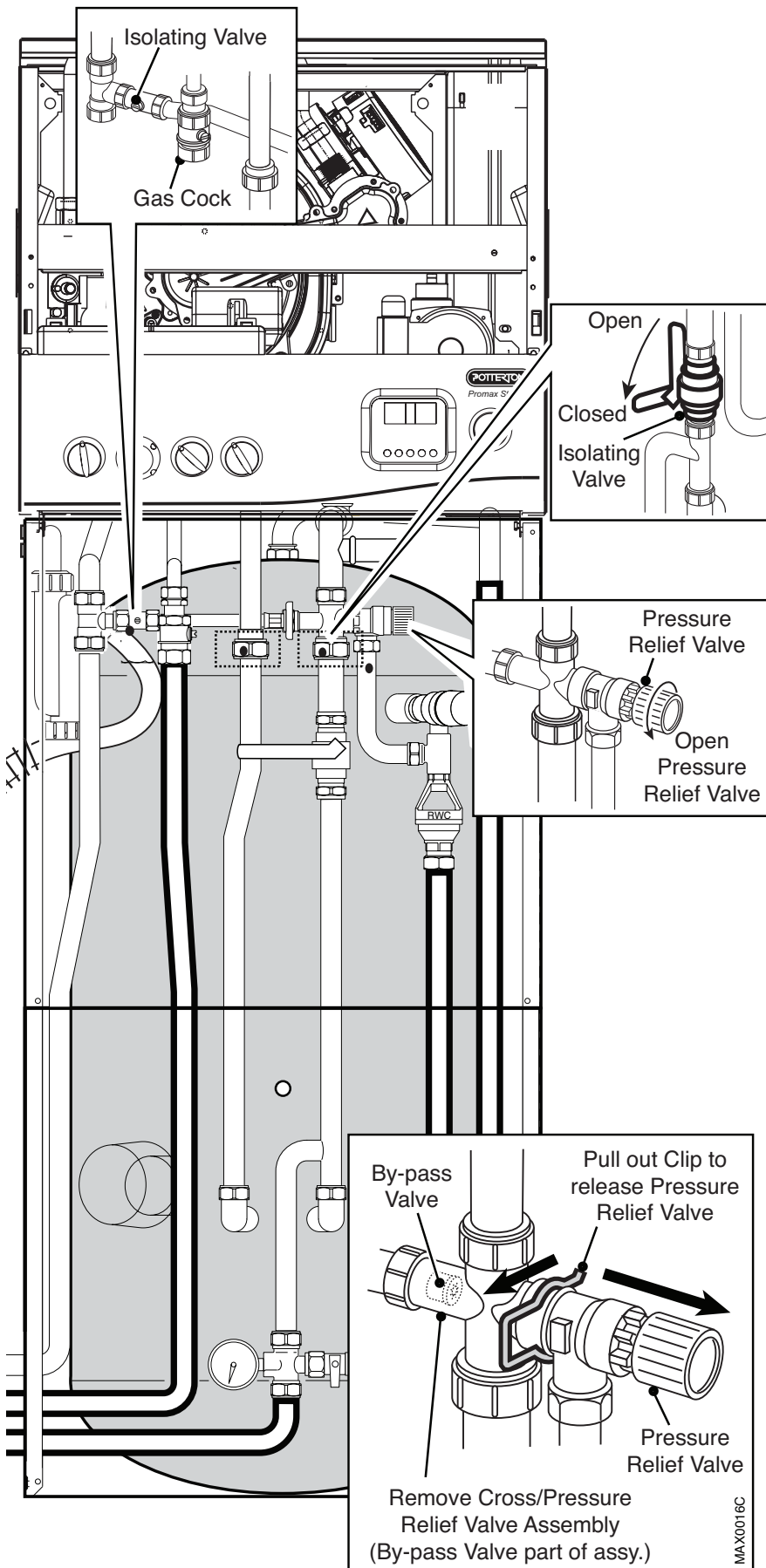

Fig. 19

4.5 Gas Valve

1. Turn the gas cock OFF and undo the screw on the bracket below the valve.
2. Pull off the earth lead and sensing pipe.
3. Undo the nut on the venturi inlet pipe and slacken the nut on the venturi. Ease the pipe aside and remove the gas valve.
4. Remove the inlet and outlet adaptors and inlet pipe and transfer them to the new valve. Examine the 'O' ring seals, replace if necessary.
5. Reassemble in reverse order.

IMPORTANT: The CO₂ must be checked and adjusted (see Commissioning Checks on p.35 and 36).

4.6 Fan

1. Remove the air box front cover.
2. Undo the nut on the gas inlet pipe to the venturi and pull the sensing pipe off the fan. Examine the sealing washer and replace if necessary.
3. Undo the screws securing the manifold to the extension piece.
4. Partially remove the manifold and fan assembly, being careful to retain the injector in the venturi. Disconnect the fan electrical plugs before completely removing the assembly.
5. Undo the screws securing the fan to the venturi and fit the new fan, replacing the seal if necessary.
6. Examine the gasket behind the manifold and replace if necessary.
7. Reassemble in reverse order, ensuring that the injector is in place and the sensing pipe is connected to the fan.

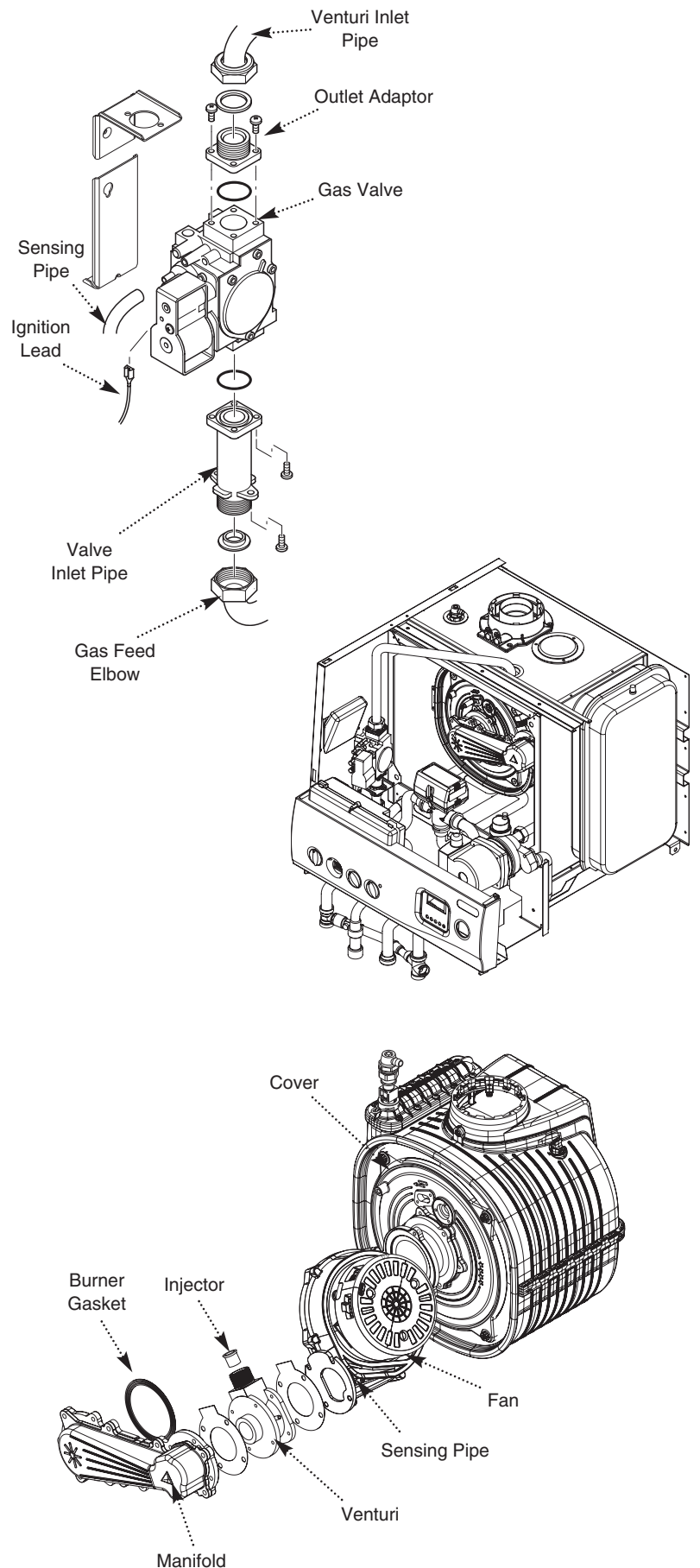
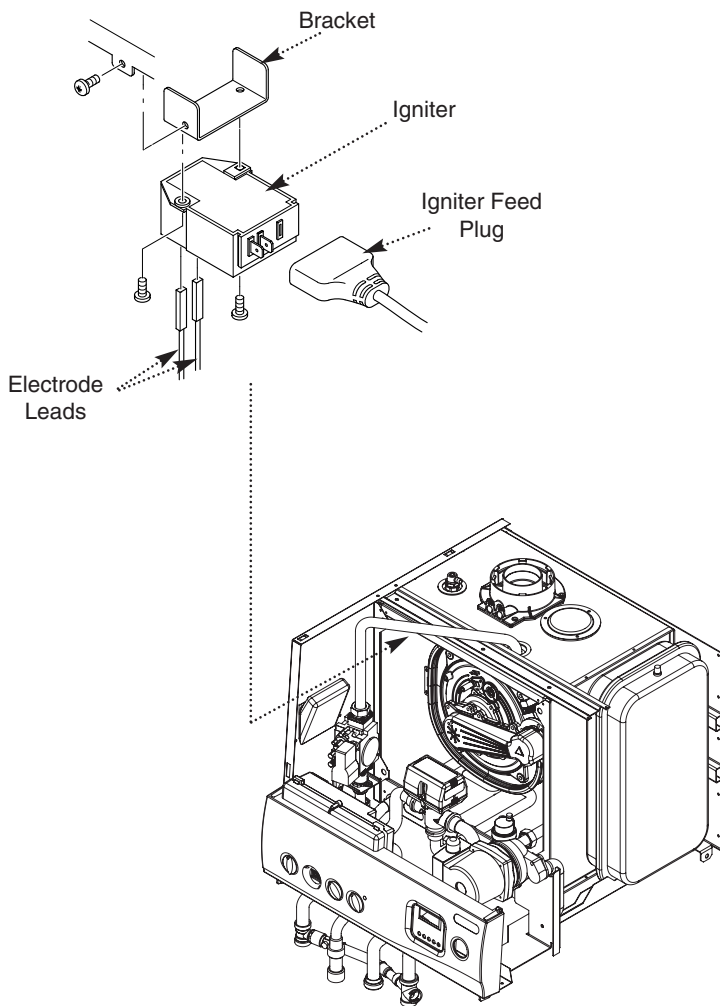

Fig. 20



4.7 Igniter

1. Remove the air box front cover.
2. Disconnect the igniter feed plug and the electrode leads, noting their positions.
3. Undo the screw securing the bracket to the boiler.
4. Remove the igniter and transfer the bracket to the new component.
5. Reassemble in reverse order.

4.8 Spark and Sensing Electrodes

1. Disconnect the electrode leads, noting their positions.
2. Remove the retaining screws securing each of the electrodes to the combustion box cover and remove the electrodes.
3. Check the condition of the sealing gaskets and replace if necessary. Reassemble in reverse order.

4.9 Overheat Thermostat

Re-assemble all parts in reverse order.

1. Perform 4.1 General Access.
2. Disconnect electrical connections and unscrew the thermostat. Polarity of the wires is not important.

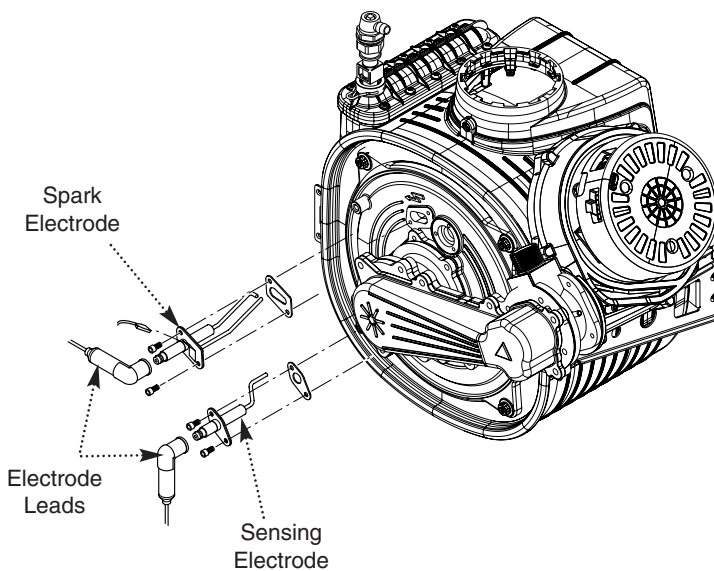
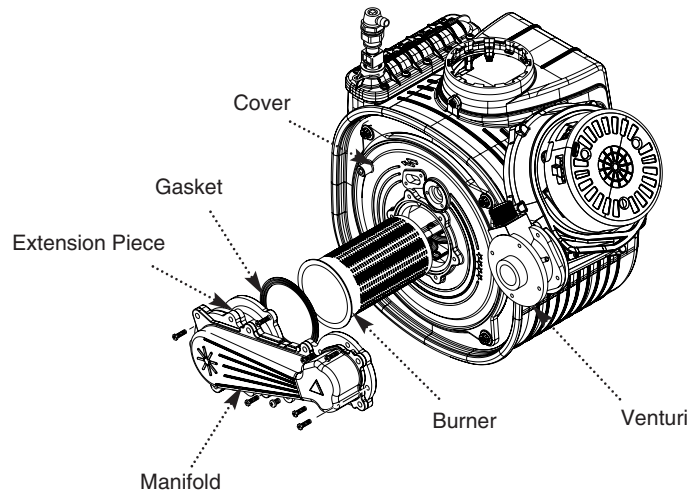

Fig. 21

4.10 Burner

1. Remove the fan/manifold assembly - see Section 4.6.
2. Undo the screws securing the spacer to the cover.
3. Withdraw the burner from the cover and replace with the new one.
4. Replace the burner gasket.
5. Reassemble in reverse order.



4.11 Insulation

1. Remove the electrode leads, noting their positions. Also remove the electrodes.
2. Undo the screws securing the cover to the heat exchanger. Draw the cover assembly away.
3. Remove the cover insulation piece.
4. Fit the new insulation carefully over the burner and align it with the slots for the electrodes.
5. The rear insulation is retained by a screw and large washer, remove these and draw the insulation out of the heat exchanger.
6. Examine the cover seal and replace if necessary.

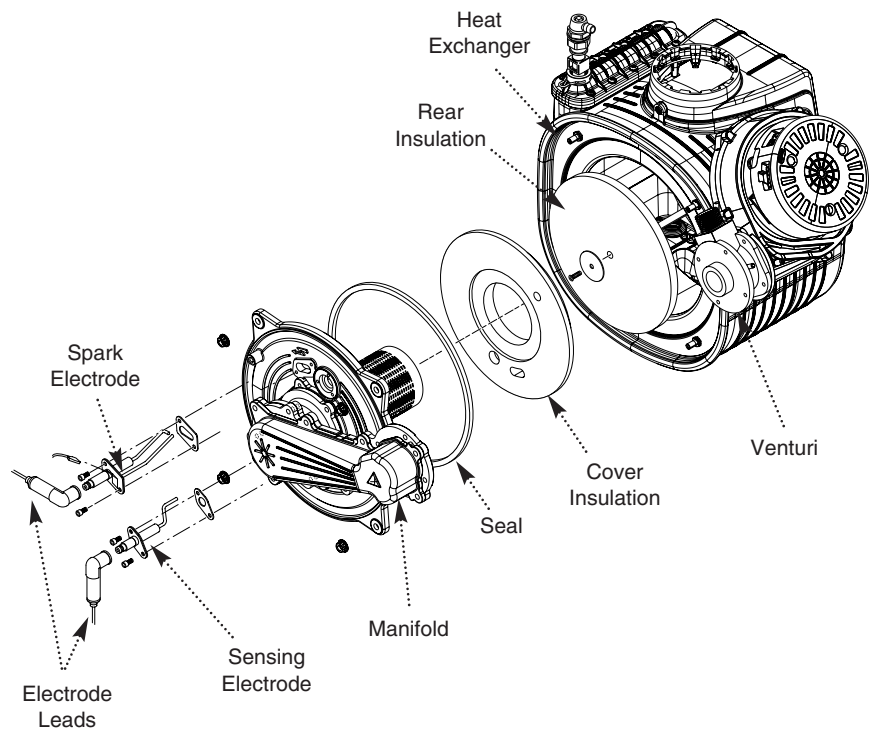
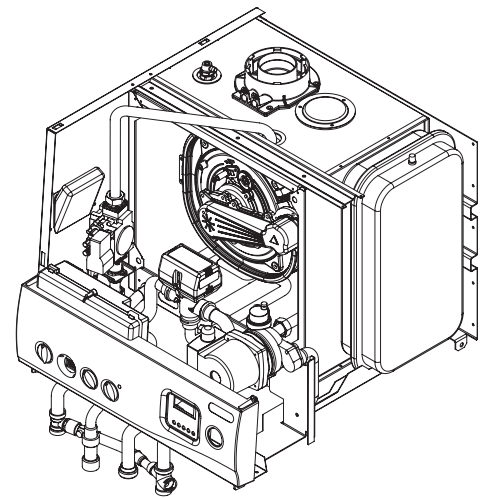

Fig. 22

4.12 Diverter Valve Actuator

Re-assemble all parts in reverse order.

1. Perform 4.1 General Access.
2. Disconnect the electrical connector at the actuator.
3. Release the locking catch and twist the actuator until it unlocks from the valve and remove from the boiler.

Diverter Valve Complete

Re-assemble all parts in reverse order.

1. Perform 4.1 General Access.
2. Check that the boiler primary system is isolated from mains water supply.
3. Release pressure from primary system and drain down until water level is below the valve.

NOTE: A convenient way to check the water level is to drain all water to the level of the primary expansion relief valve.

NOTE: The markings on the valve body are an aid to correct installation (See Fig. 23).

4. Remove the three spring clips from the connections and remove the valve from the boiler.

Manual Air Vent

5. Unscrew vent from its mounting.

See Commissioning Instructions, Page 35 for procedure to re-fill and vent the sealed primary system.

4.13 Temperature Flow & Dry Fire Sensors

6. Disconnect the electrical connector and unscrew the sensor.

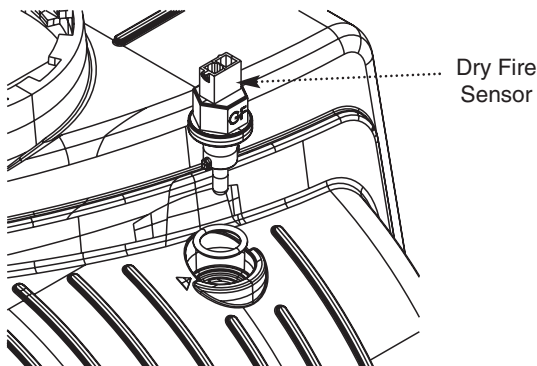
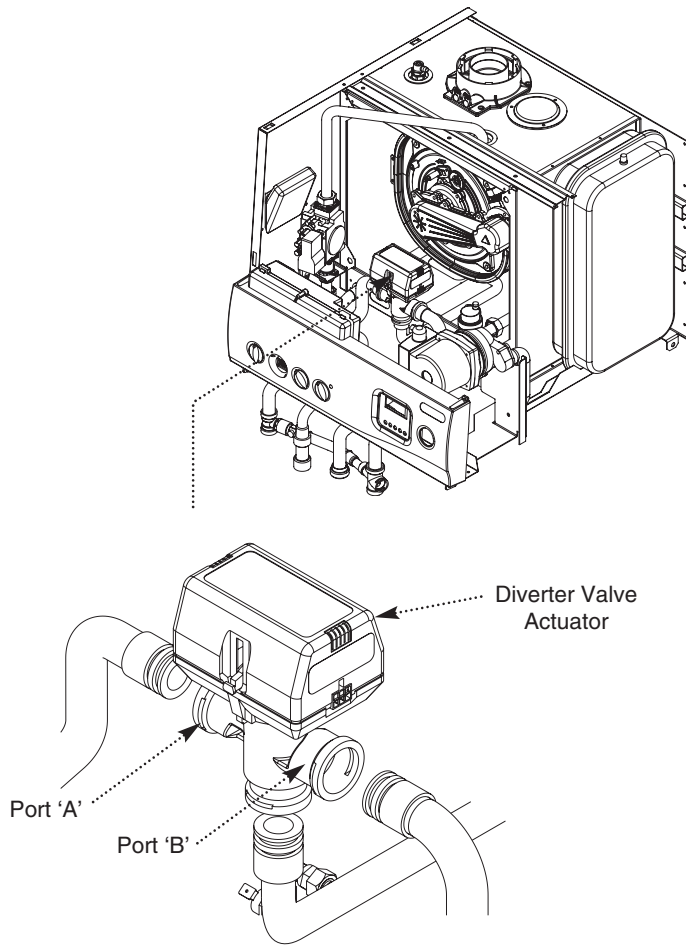

4.14 Heat Exchanger

NOTE: Replacing the heat exchanger involves disconnecting the appliance from the flue and air pipes. It is essential that the flue system is fully reinstated and tested so we recommend that the appropriate replacement flue pipe and fittings be obtained before starting this work.

Re-assemble all parts in reverse order.

1. Perform 4.1 General Access.
2. Check that the boiler primary system is isolated from the mains water supply. Release pressure from the primary system and drain down.
3. Remove expansion vessel, pump, gas valve, fan/venturi, diverter valve and heat exchanger door (complete with burner) all as detailed in previous sections. Remove flow and return pipework from the push-fit connections on the manifold underneath the heat exchanger. Retain securing clips for re-use.
4. Disengage the flue/air inlet duct/elbow on top of the boiler. Unscrew the 4 c/sunk screws and remove the flue connector fitting.
5. Disconnect wiring from temperature sensors and overheat thermostat. Remove the spark generator and leads. Remove the ionisation probe.
6. Disconnect the flexible condensate pipe at the union just inside the airbox.
7. Remove two flanged set screws securing the heat exchanger. Support weight of heat exchanger before removing the clips entirely.
8. Manoeuvre the heat exchanger away from the support brackets, then tilt forward from the bottom to remove.
9. Transfer the extension for the manual vent to the new heat exchanger.

4.15 Replacement of Immersion Heater and Immersion Heater Combined Thermostat/Thermal Cut-out

The cylinder must be fully drained prior to removing the immersion heater. Refer to Section 2.8 for the procedure to drain the unit.

- Important: Ensure ALL power supplies are isolated before starting work on the boiler.**
Perform the actions detailed in section 4.1 General Access.
Note: only the two lower front panels need be removed for this servicing action, follow instructions 3 and 4 for how to remove these panels.
- Remove the immersion heater cover by removing the securing nut and pulling the cap away from the cylinder.
- Disconnect the electrical supply cable from the thermostat and the earth post assembly. Remove the thermostat from the immersion heater by carefully pulling outwards. **DO NOT** twist the thermostat as damage to the connections to the immersion heater may occur.
- To remove the immersion heater unscrew the brass backnut using the key spanner supplied with the unit. Retain the backnut. Over time the immersion heater gasket may become stuck to the mating surface. To break the seal insert a round bladed screwdriver into one of the pockets on the immersion heater and gently lever up and down.
- Withdraw the immersion heater from the cylinder.
Note: the immersion heater is curved downwards 90 degrees to reach the base of the cylinder. When removing, the head of the immersion heater should be tilted towards the floor for ease of withdrawal.
- Insert the immersion heater into the boss ensuring the right angled element hangs vertically downwards towards the base of the unit. Push the immersion heater mounting plate into the boss so the gasket seats on the flange at the base of the boss. It may be helpful to support the immersion heater using a round bladed screwdriver inserted into one of the pockets on the immersion heater whilst the brass backnut is tightened. Tighten the brass backnut using the key spanner supplied.
- Fit the thermostat by sliding the stem into the upper pocket and carefully plugging the two male spade terminals on the underside of the thermostat head into the corresponding female terminations on the element. Carefully push home until the terminals are fully engaged.
- Re-connect the electrical supply to the thermostat and earth post.
The Live (Brown) conductor should be connected directly to the thermostat terminal marked A.
The Neutral (Blue) conductor should be connected directly to the thermostat terminal marked B.
The earth conductor should be connected to the threaded post on the bracket marked \perp .
- Re-fit the protective cover over the immersion heater assembly and secure using the nut previously removed.
- Ensure the cylinder is correctly re-filled prior to switching on the immersion heater. Do not operate the immersion heater with the protective cover removed.

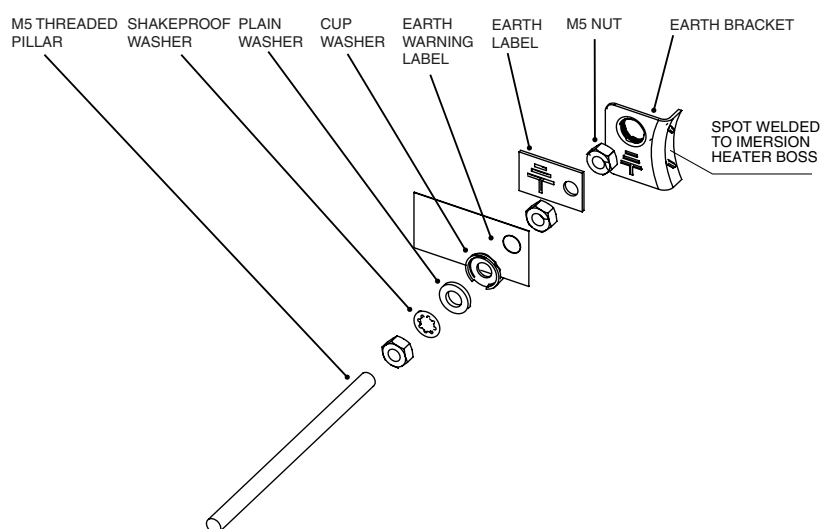
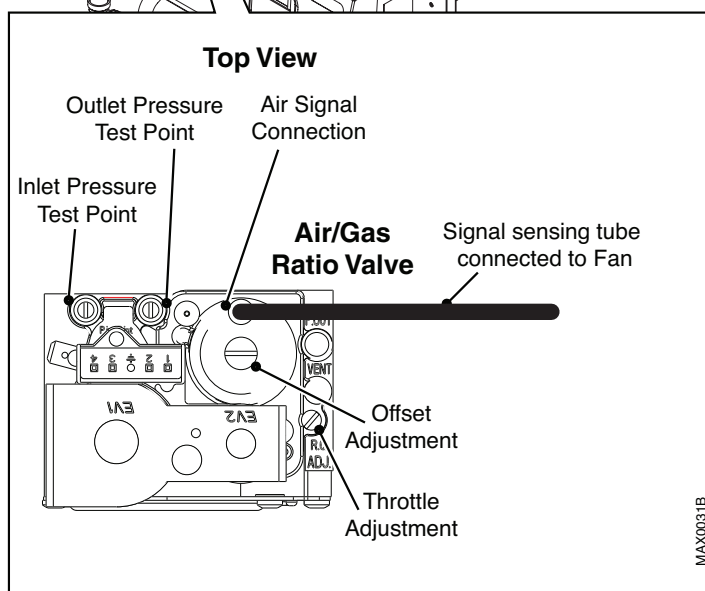
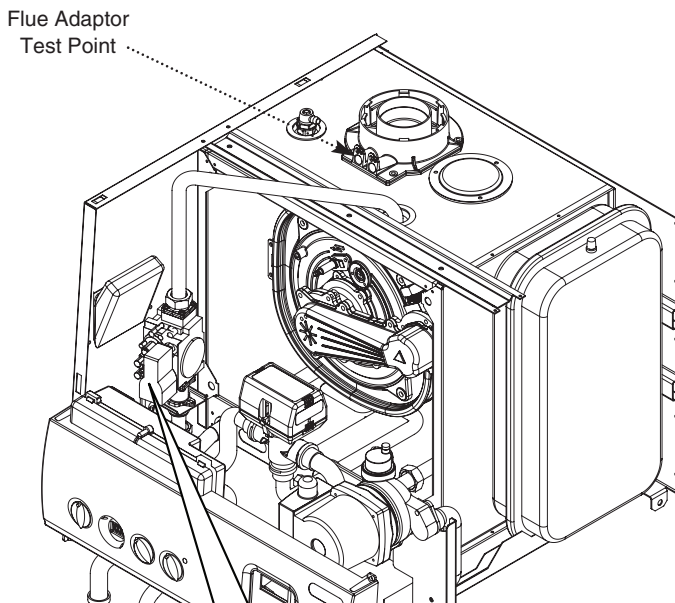

Fig. 25

4.16 Gas/Air Valve Setup Procedure

Checking the CO₂

1. The combustion (CO₂) may be checked at maximum rate using a suitably calibrated analyser after running the boiler for several minutes.
2. To do this it is necessary to set the boiler to 'Calibration Mode'.
3. Ensure that all external controls are calling for heat. The actual current boiler temperature is shown on the display.
4. Turn both temperature control knobs fully anticlockwise, then quickly turn the DHW temperature knob 1/4 clockwise twice and back fully anticlockwise.
5. The display will now alternate between 'SF' and the current boiler temperature and both green LEDs will flash.
6. Turn the CH temperature knob fully clockwise. As the knob is turned the display will change, indicating the percentage of maximum fan speed.
7. The display will show '00', indicating maximum rate, then revert to 'P' alternating with the current boiler temperature.
8. Remove the plug from the flue adaptor test point. Insert the analyser probe and allow time for the reading to settle.
The CO₂ should be 8.9% ± 0.2
9. It is possible to alter the CO₂ by adjustment of the gas valve. At maximum rate the 'Max. Rate' throttle adjustment screw should be turned clockwise to decrease CO₂, anti-clockwise to increase CO₂ using a suitable 2.5mm hexagon key, until the correct reading is obtained.
10. The CO₂ must then be checked at minimum rate. Turn the CH temperature knob fully anticlockwise. As the knob is turned the display will change, indicating the fan speed. When the display reads '0' the boiler runs at minimum rate.
The CO₂ should be 8.6% ± 0.2.
11. If at minimum CO₂ is not correct please ring our after sales service department.
12. The 'Calibration Function' is maintained for 20 minutes unless the maximum CH temperature is exceeded. The function can be disabled at any time by turning the DHW knob.



	Burner Pressure (mb)	Gas Rate (m ³ /hr)	CO (ppm)	CO ₂ (%)
Min Gas Rate	0.6 - 0.8	0.7 - 0.74	2 - 30	8.4 - 8.8
Max Gas Rate	6.8 - 7.2	2.48 - 2.74	30 - 80	8.7 - 9.2

5. Wiring Diagrams

Wiring/Functional Flow Diagram

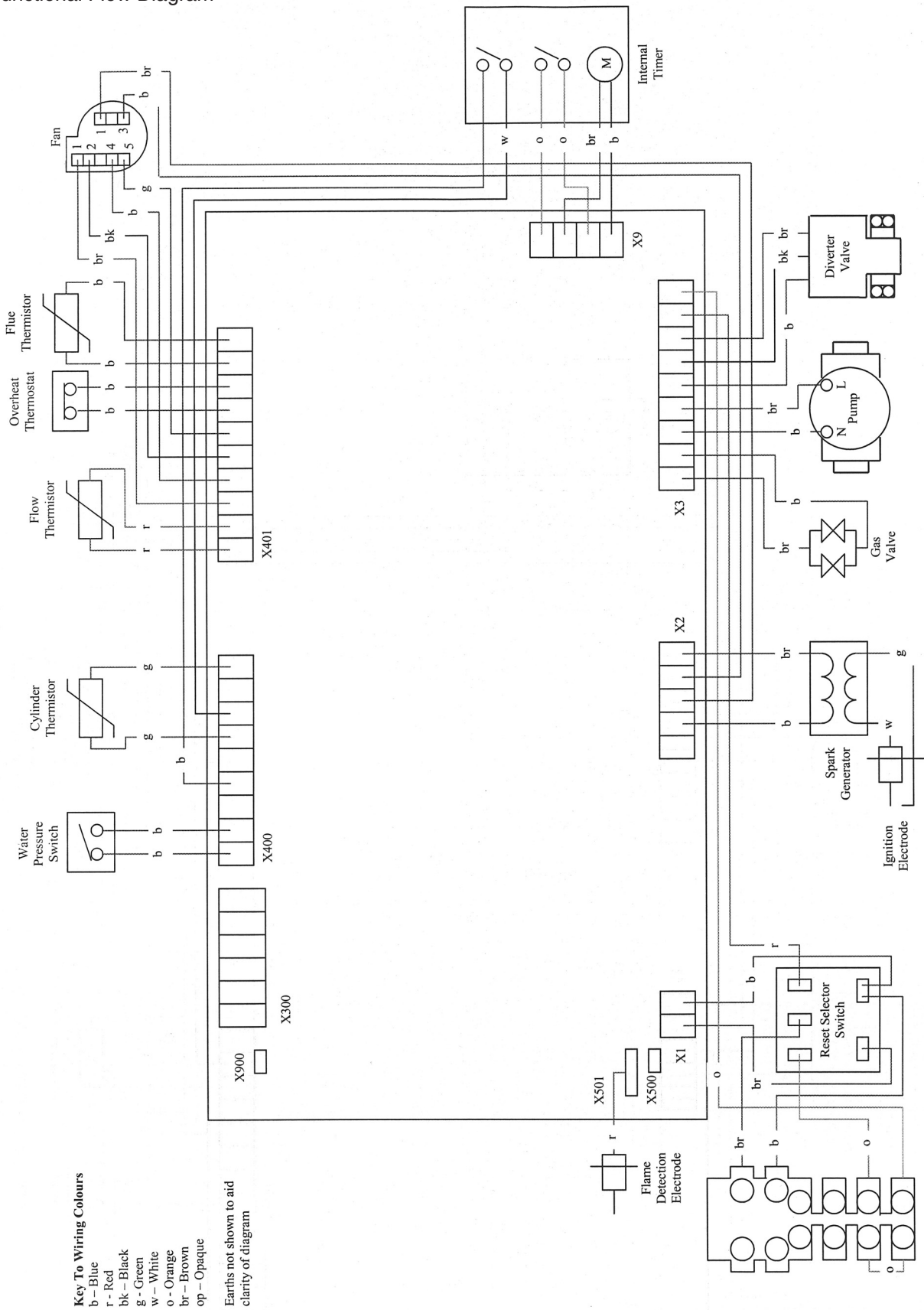
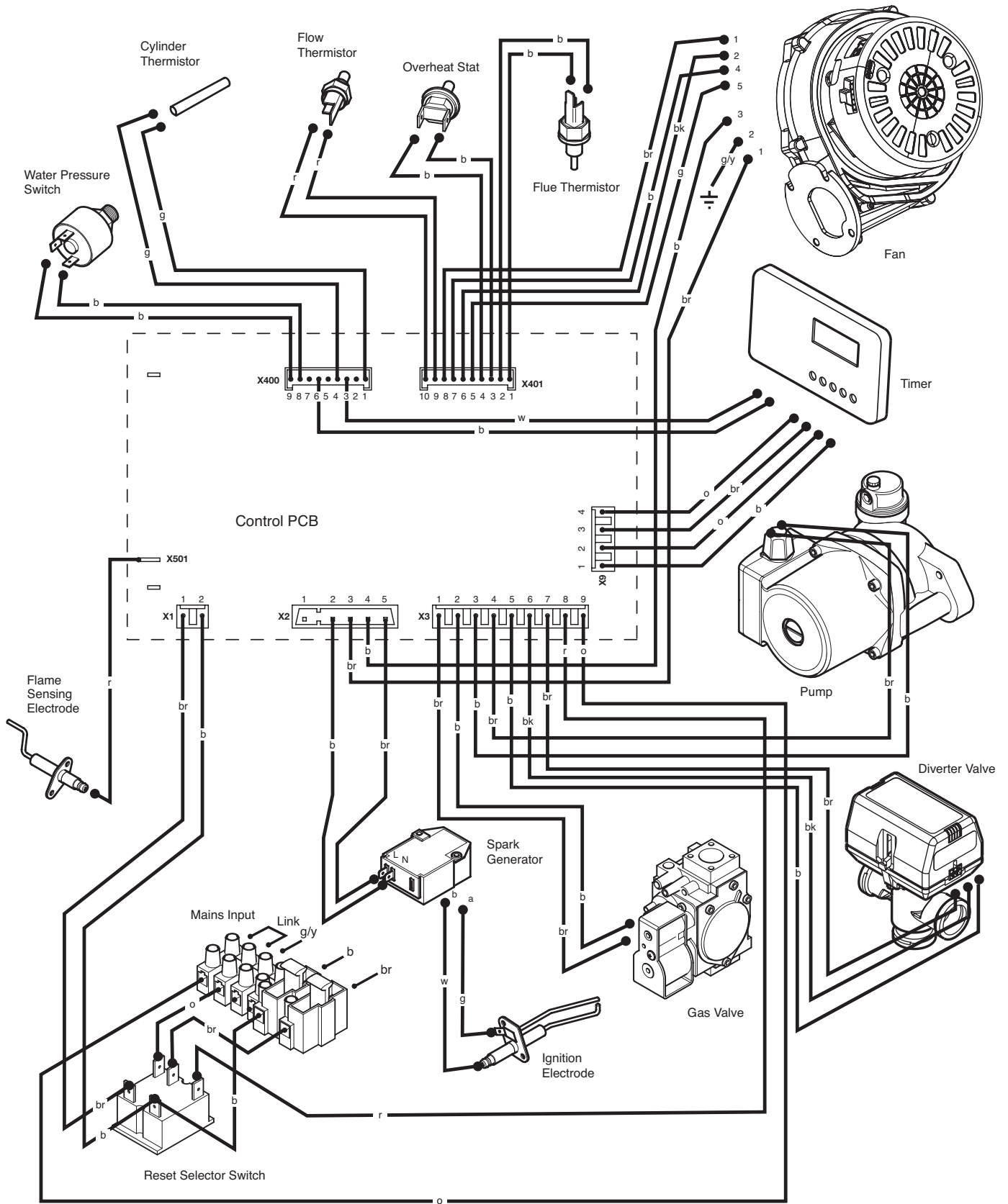

Fig. 27



- br - brown g - green
- bk - black g/y - green / yellow
- b - blue r - red
- w - white o - orange

Fig. 28

6. Fault Finding Guide

Boiler Fault Finding

NOTE: When instructed to turn the selector to the reset position turn the selector switch fully anticlockwise against the spring pressure to the reset position and hold for 5 seconds to reset the boiler.

Table Of Error Codes

E20	Central Heating NTC Fault
E50	Flue NTC Fault
E28	Hot Water NTC Fault
E110	Safety Thermostat Operated
E119	Water Pressure Switch Not Operated
E125	Pump Fault or Primary Circulation Problem Tank Thermistor not in Tank
E130	Flue NTC Operated
E131	Interruption Of Power Supply while in fault mode
E133	Interruption Of Gas Supply or Flame Failure
E160	Fan or Fan Wiring Fault
E193	Pre-Circulation Fault

Initial Fault Finding Checks

1. Check that gas, water and electrical supplies are available at the boiler.
2. Electrical supply = 230V ~ 50 Hz.
3. CH water system pressurised to 0.5 bar minimum when the boiler is cold.
4. The preferred minimum gas pressure is 20 mbar.
5. Carry out electrical system checks, i.e. Earth Continuity, Resistance to Earth, Short Circuit and Polarity with a suitable meter.

NOTE: These checks must be repeated after any servicing or fault finding.

6. Ensure all external controls are calling for heat and check all external and internal fuses. Before any servicing or replacement of parts, ensure the gas and electrical supplies are isolated.

Error Codes

1. If a fault occurs on the boiler an error code may be shown by the facia display.
2. The codes are either two or three digit, preceded by the letter 'E'. For example, code E133 will be displayed by 'E1' alternating with '33'. E50 is shown as 'E' then '50'

E20, E28 & E50 indicate faulty components or wiring harness.

E110 shows overheat of the primary water and E130 overheat of the flue system.

E119 is displayed when the primary water pressure is less than 0.5 bar.

E133 indicates that the gas supply has been interrupted, ignition has failed or the flame has not been detected.

E125 is displayed in either of two situations:-
i) If within 15 seconds of the burner lighting the boiler temperature has not changed by 1°.
ii) If within 10 minutes of the burner lighting the boiler temperature twice exceeds the selected temperature by 30°.
In these instances the pump is probably inoperative.

3. By turning the selector switch to the 'Reset' position for a minimum of 5 seconds when E110, E130 & E133 are displayed it is possible to relight the boiler.

4. If this does not have any effect, or the codes are displayed regularly further investigation is required.

Refer to Section "Illustrated Wiring Diagram" for position of terminals and components
Central Heating - Follow operational sequence

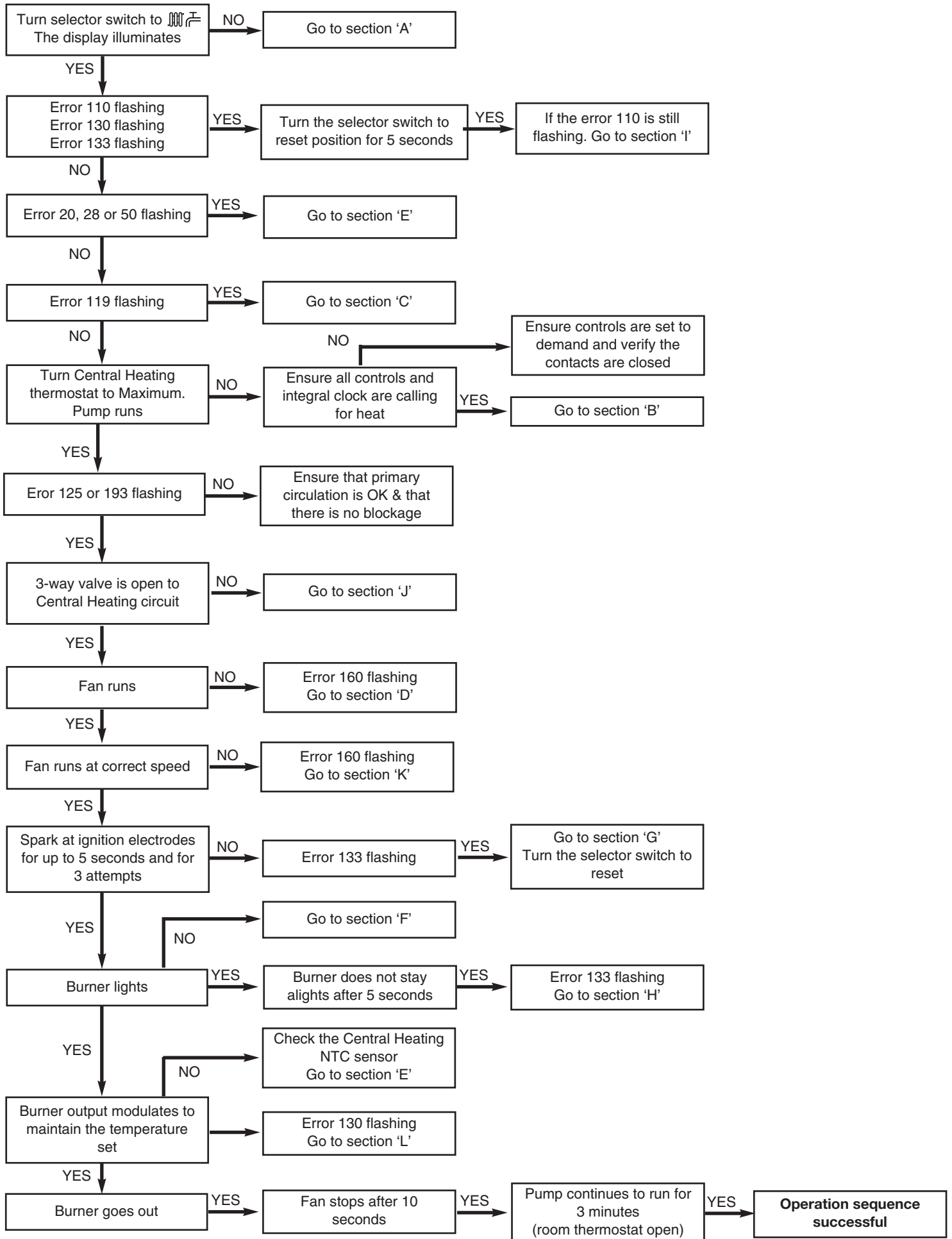

Domestic Hot Water - Follow operational sequence

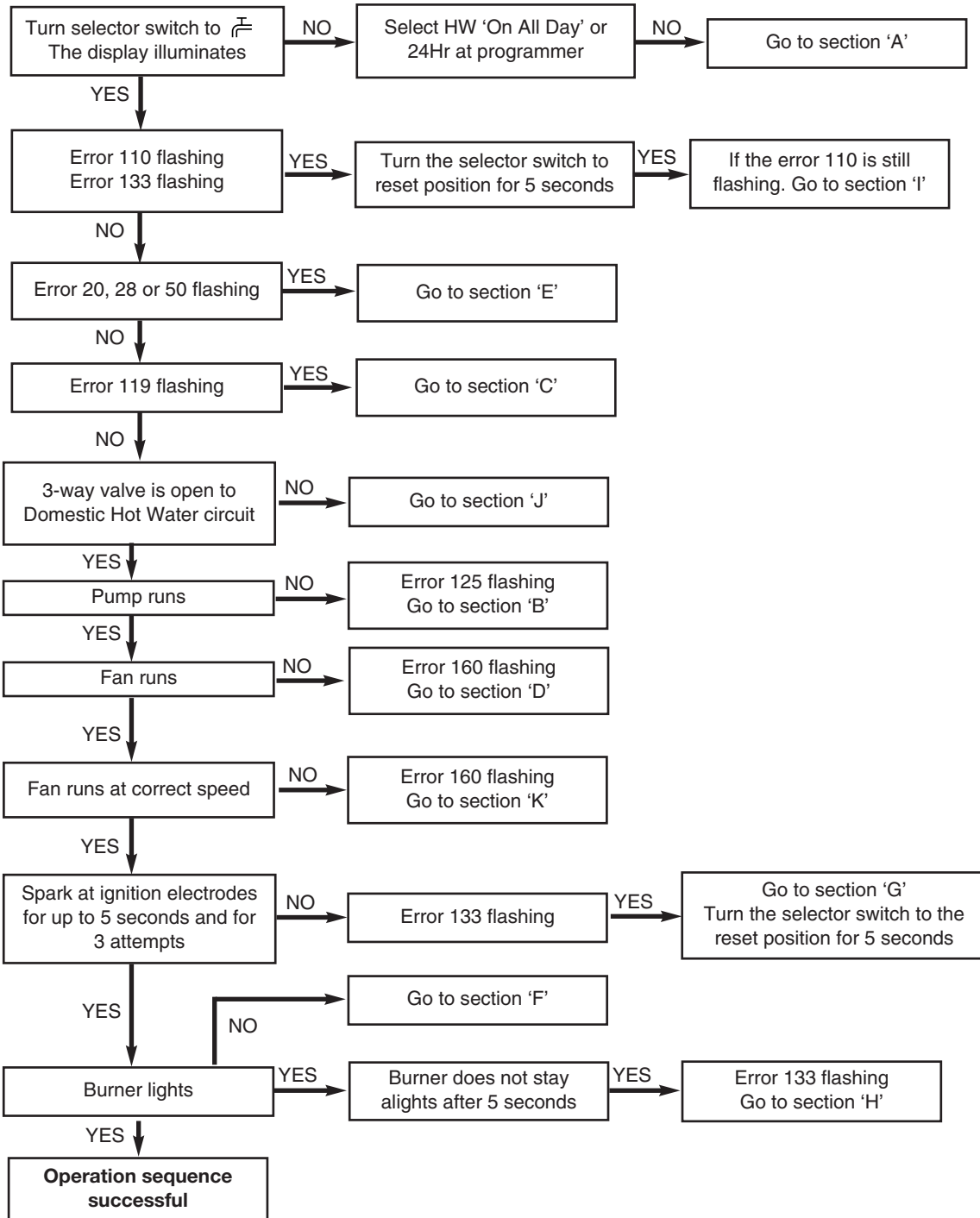

Fault Finding Solutions Sections

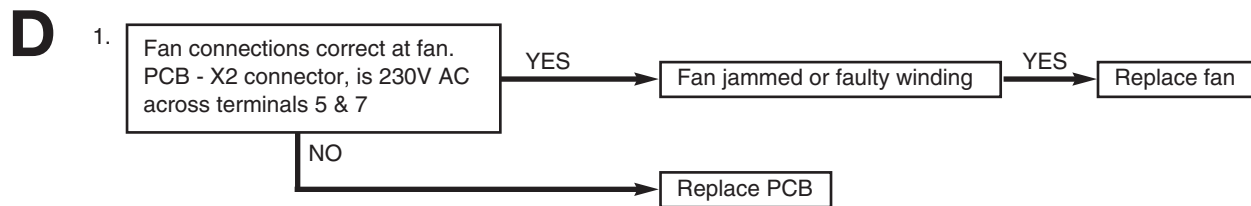
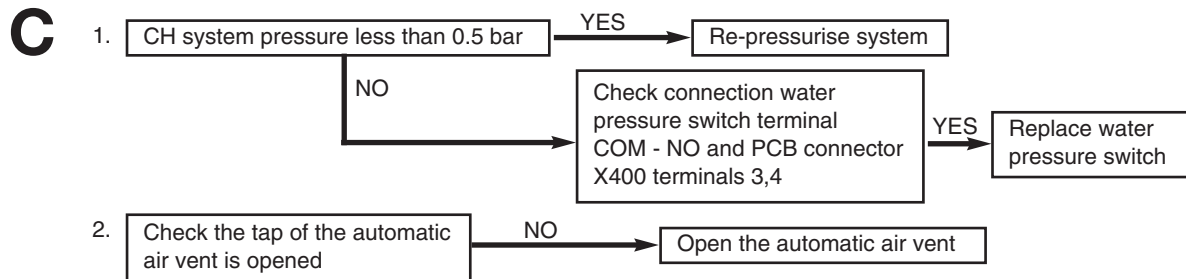
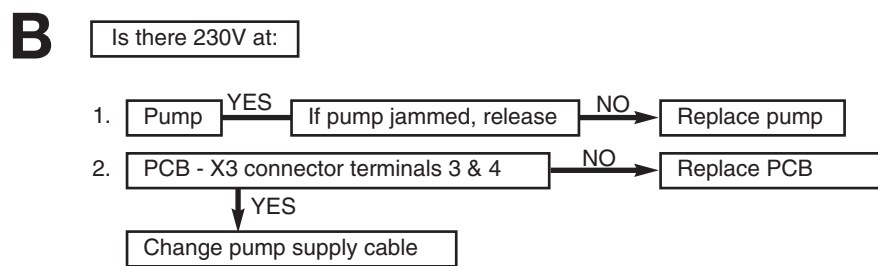
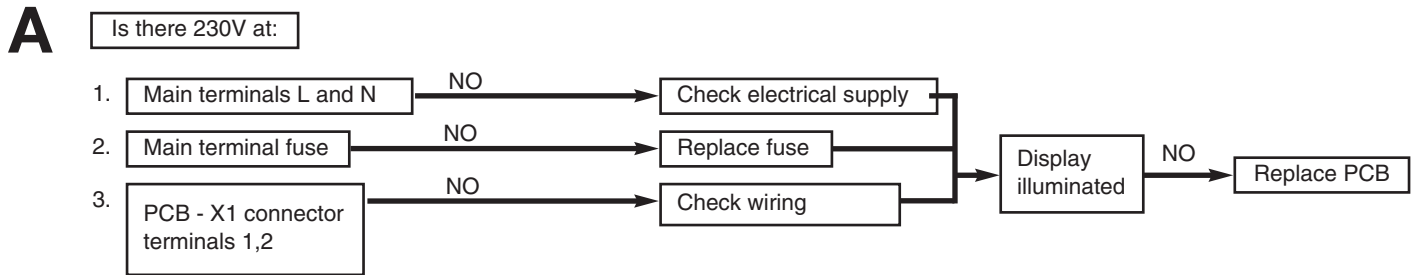

E

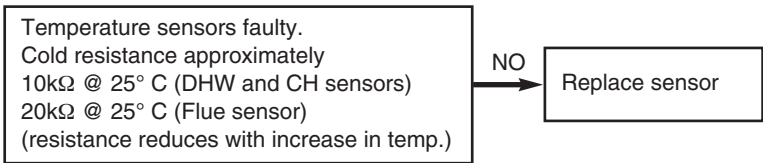

F

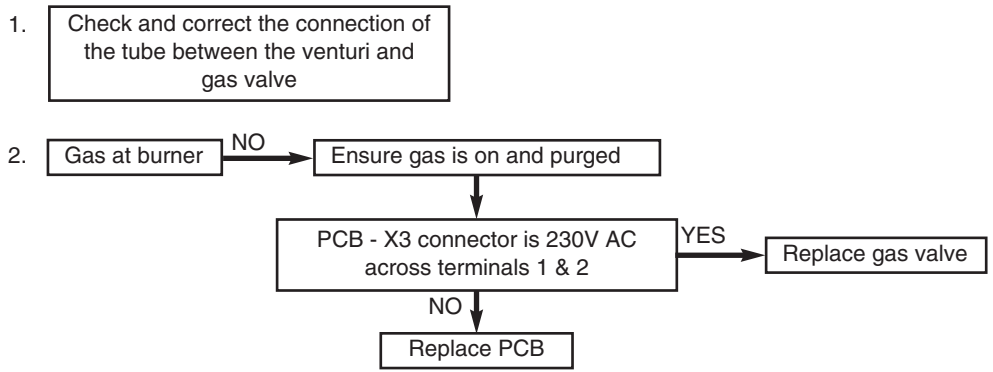

G

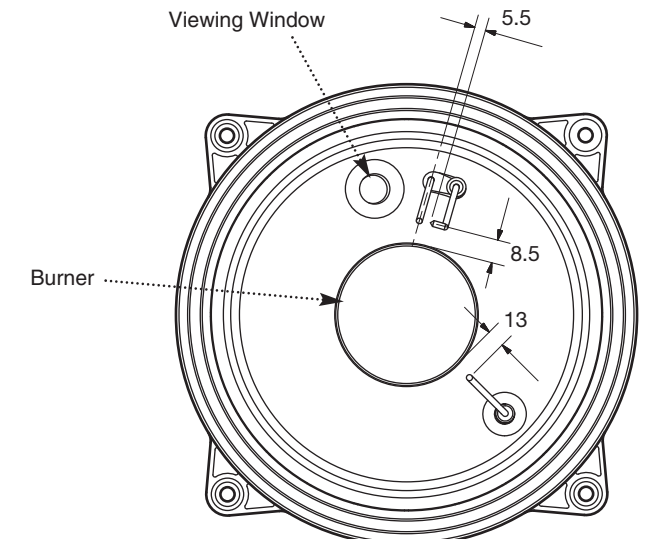
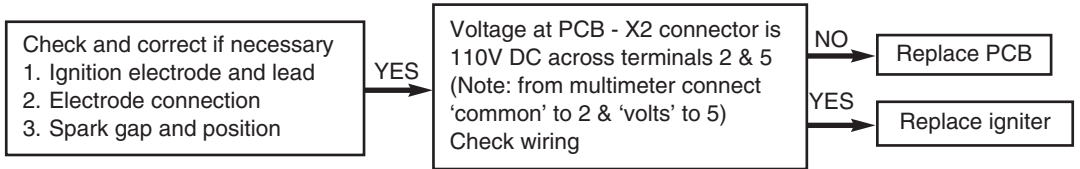

H

1. Check the gas supply pressure:
For Natural Gas greater than
10 - 11 mbar

2. Check and correct if necessary
1. The mechanical set of the gas valve
(CO₂ values - see instruction)
2. Flame sensing electrode and lead connections
3. Flame sensing electrode position

Flame current should be more than 0.5 μ A

YES

Replace PCB

NO

Replace flame sensing electrode

I

1. Overheat thermostat operated
or faulty, i.e. continuity across
thermostat terminals

NO

Allow to cool. Continuity
across thermostat terminals
more than 1.5 ohm

YES

Replace safety thermostat

YES

Replace PCB

J

Is there 230V at:

1. Motor 3-way valve

YES

Replace diverter valve actuator

2. PCB - X3 connector terminals
5 & 6 central heating mode
5 & 7 domestic hot water mode

NO

Replace PCB

YES

Change pump supply cable

K

1. Fan connections correct at fan.
PCB - X401 connector terminals 5,6,7 & 8

YES

Replace fan

L

1. Temperature sensors faulty.
Cold resistance approximately
10k Ω @ 25° C (CH sensor)
20k Ω @ 25° C (Flue sensor)
(resistance reduces with increase in temp.)

NO

Replace sensor

2. If pump is running the heat exchanger could
be obstructed

YES

Replace heat exchanger

7. Short List Of Spare Parts

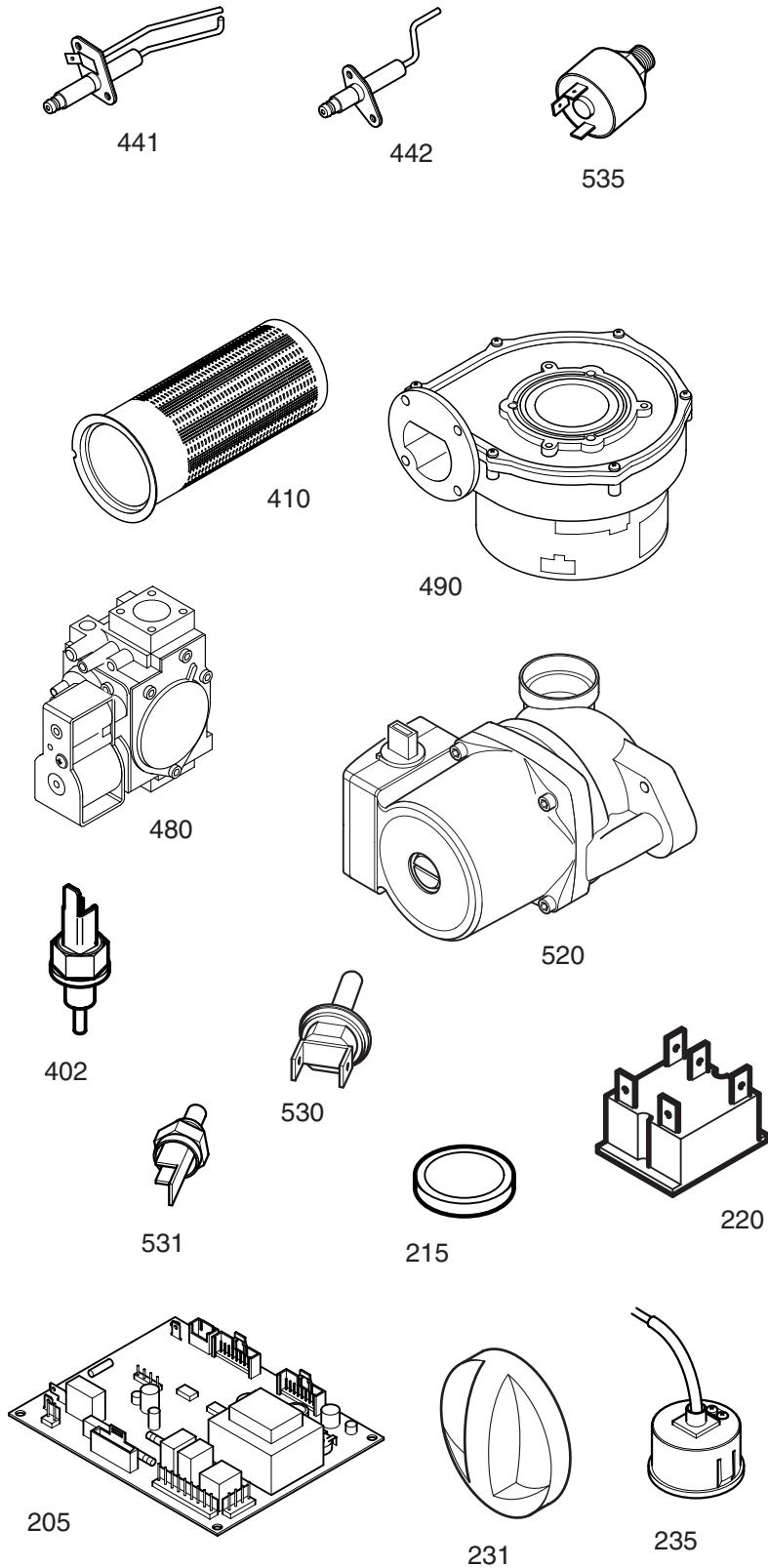

Short Parts List

Key No.	Description	Manufacturers Part No.
490	Fan	5129230
441	Igniter Electrode	5114702
442	Sensing Electrode	5117275
480	Gas Valve	5119647
410	Burner	5114697
535	Water Pressure Switch	5114748
520	Pump	248042
402	Flue Thermostat	5114747
531	NTC Sensor	5114725
530	Overheat Thermostat	5106291
235	Pressure Gauge	248090
205	PCB	5117086
220	Selector Switch	248095
215	Battery (Programmer)	5118231
231	Knob	5116069

Fig. 29

SERVICE RECORD

It is recommended that your heating system is serviced regularly and that the appropriate Service Record is completed.

Service Provider

Before completing the appropriate Service Record below, please ensure you have carried out the service as described in the manufacturer's instructions.

Always use the manufacturer's specified spare part when replacing controls.

SERVICE 1 Date

Energy Efficiency Checklist completed? Yes No

Engineer Name

Company Name

Telephone Number

Gas Safe Register licence No.

Comments

Signature

SERVICE 2 Date

Energy Efficiency Checklist completed? Yes No

Engineer Name

Company Name

Telephone Number

Gas Safe Register licence No.

Comments

Signature

SERVICE 3 Date

Energy Efficiency Checklist completed? Yes No

Engineer Name

Company Name

Telephone Number

Gas Safe Register licence No.

Comments

Signature

SERVICE 4 Date

Energy Efficiency Checklist completed? Yes No

Engineer Name

Company Name

Telephone Number

Gas Safe Register licence No.

Comments

Signature

SERVICE 5 Date

Energy Efficiency Checklist completed? Yes No

Engineer Name

Company Name

Telephone Number

Gas Safe Register licence No.

Comments

Signature

SERVICE 6 Date

Energy Efficiency Checklist completed? Yes No

Engineer Name

Company Name

Telephone Number

Gas Safe Register licence No.

Comments

Signature

SERVICE 7 Date

Energy Efficiency Checklist completed? Yes No

Engineer Name

Company Name

Telephone Number

Gas Safe Register licence No.

Comments

Signature

SERVICE 8 Date

Energy Efficiency Checklist completed? Yes No

Engineer Name

Company Name

Telephone Number

Gas Safe Register licence No.

Comments

Signature

SERVICE 9 Date

Energy Efficiency Checklist completed? Yes No

Engineer Name

Company Name

Telephone Number

Gas Safe Register licence No.

Comments

Signature

SERVICE 10 Date

Energy Efficiency Checklist completed? Yes No

Engineer Name

Company Name

Telephone Number

Gas Safe Register licence No.

Comments

Signature

All descriptions and illustrations provided in this leaflet have been carefully prepared but we reserve the right to make changes and improvements in our products which may affect the accuracy of the information contained in this leaflet. All goods are sold subject to our standard Conditions of Sale which are available on request.

POTTERTON

A Trading Division of Baxi Heating UK Ltd (3879156)

A Division of Baxi Group

Brooks House, Coventry Road, Warwick. CV34 4LL

After Sales Service 0844 871 1560 Technical Enquiries 0844 871 1555

Website www.potterton.co.uk

e&oe

A BAXI GROUP company