

## *Ballorex commissioning valves*

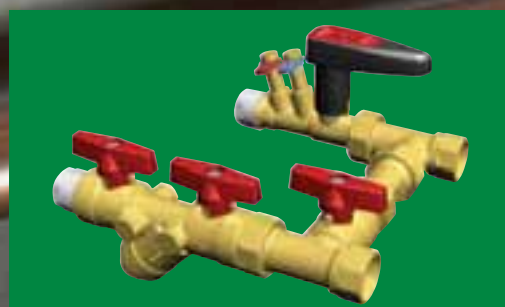

# Pegler Yorkshire

Unrivalled quality, innovation,  
customer service and long-term  
value for money

As part of the global Aalberts Industries NV Group, Pegler Yorkshire is one of Britain's largest and most respected manufacturers of innovative products for the demanding and diverse plumbing and heating industries.

## Pegler Yorkshire – a unique story

It was in the late 19th century when two separate and altruistic companies set out on the long road to satisfying the needs of prospective customers and, of course, to profit in the process. Coincidentally located just 30 miles apart, each was driven by the same vision and ideals of a no-compromise culture. Cutting corners was never an option and only the best could ever be good enough.

These two companies were Pegler and Yorkshire Fittings. Although in meeting all the challenges of the 20th and 21st centuries each has changed a great deal, the business ethos common to both never has. And now these two like minds have come together as Pegler Yorkshire – a single source of proven, flow control solutions for installers, specifiers and engineers in the domestic, public and commercial markets.

## Reputable and established brands

Just as Pegler and Yorkshire have endured over such a long period, many of the brand names they have created over time are similarly very well established, in many cases as market leaders in their respective categories. The very extensive Pegler Yorkshire product range now comprises more than 15,000 lines – without rival for the choice and coverage it offers and for the number and scope of applications it satisfies.

## A mind for innovation

Brands which endure and are not easily displaced must by definition be the product of innovative thinking and technology that continually stand the test of time. Pegler Yorkshire's no-compromise philosophy will always put new product development high on the agenda, based on not only meeting the needs of today's markets, but also anticipating and meeting customers' future needs.

## The true value of knowledge

As well as the benefit of unparalleled experience of the flow control market and its growth over many decades, Pegler Yorkshire has strong associations with major industry bodies such as those responsible for determining product and performance standards.

The result is a comprehensive store of knowledge and reference which is invaluable in the key areas of research, development and dealing efficiently and accurately with customer enquiries – particularly with regard to product application and suitability.

## A charter for the best in customer service

With so diverse a product range and customer base, Pegler Yorkshire's no-compromise standards of quality, reliability and value for money naturally go hand in hand with the principle of delivering the best in customer service.

## Green awareness and responsibilities

Developing products which reduce the carbon footprint by saving water and energy is only one side of the green issues coin. Pegler Yorkshire is also increasingly committed to recycling key production materials (such as brass), eliminating the need for excessive packaging wherever possible, and looking for new ways in which the company's day-to-day operations can be improved to reduce waste and minimise the impact on the environment.

Likewise, social responsibilities such as supporting employee and local community welfare are aspects of the very fabric and philosophy upon which both Pegler and Yorkshire were founded.

## Standards

Pegler Yorkshire are dedicated to designing, developing and manufacturing products of the highest quality. We are members of numerous standards committees and take an active part in their development. Our products, where applicable, comply with the relevant British, European and International standards. Whatever the latest developments, we guarantee that our products will always meet the latest and highest standards.



## Trade bodies

Pegler Yorkshire is pleased to be associated with several influential industry organisations:



Association of Plumbing and Heating Contractors



The Bathroom Manufacturers Association



Construction Products Association

## Brass

The Brass Page for specifiers, designers, engineers and manufacturers



British Plumbing Employers Council



Builders Merchants Federation



The Copper Development Association



The UK Copper Board



Institute of Plumbing



Heating and Ventilating Contractors Association



Thermostatic Mixing Valve Manufacturers Association

Thermostatic Mixing Valve Manufacturers Association



Scottish and Northern Ireland Plumbing Employers Federation

At Pegler Yorkshire we are constantly striving to develop system solutions that meet the changing needs of installers, contractors and specifiers alike. The Pegler Yorkshire range of commissioning valves comprises a number of products for a broad spectrum of applications across the commercial sector.

Pegler Yorkshire valves provide one of the most comprehensive ranges of products on the market today. Users of Pegler Yorkshire valves can be confident that they are purchasing an established product range with a proven reputation for quality and reliability.



## Ballorex Venturi

Ballorex Venturi offers a unique solution to commissioning modern heating and chilled water systems. The concepts incorporated into Ballorex Venturi provide significant benefits to consultants, contractors and commissioning engineers, enabling systems to be designed, installed and handed over without complications.

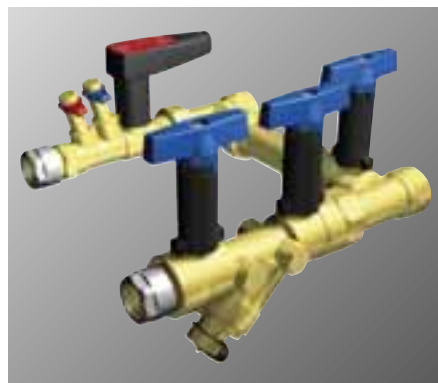

## Ballorex Modular

Ballorex Modular is an ideal solution for indoor climate control specification in commercial buildings. It is a bespoke system made up of interlinked multifunctional valves and components, factory assembled into a complete unit that provides connection, regulation, isolation, flushing and draining in one unit. The system can be configured both for heating and cooling applications.



## Ballorex Dynamic

Ballorex Dynamic is a combined pressure independent flow limiter and control valve. The valve operates independently of changes in system pressure water-based cooling or heating systems.

## Glossary of terms

### Fixed Orifice (FO)

The part of the flow measurement device which induces the pressure differential for flow measurement and is of a fixed dimension and geometry.

### Double Regulating Valve (DRV)

A valve for flow rate regulation with established characteristics, allowing a set point to be maintained independently of the isolation function.



### Differential pressure or signal (Dp or ΔP)

The difference in the pressure between the upstream and downstream pressure tapping points over the measurement device. Normally measured in kPa or mmH2O.

### Loss factor

The loss factor is a non-dimensional parameter which expresses the total head loss across the valve as a percentage of the signal when the valve is fully open.

## Ballorex Venturi Commissioning valves

The Ballorex Venturi valve provides an ideal solution for commissioning modern heating and chilled water systems in commercial applications. The range incorporates both static and dynamic commissioning valves and a variety of accessories.

At the heart of all Ballorex Venturi valves is the integrated fixed orifice Venturi. The Venturi principle was first demonstrated in 1797. Applied in the Ballorex Venturi valve, water is accelerated through a waisted orifice which increases the velocity of the flow and the pressure differential, proportionally amplifying the signal generated. The signal from a Venturi can be increased or decreased by enlarging or reducing the waisted orifice in relationship to the pipe diameter (Beta ratio). The benefit of the Venturi over the traditional orifice plate is that the signal developed is not a direct loss. Significant pressure drop is recovered after the water has passed through the venturi nozzle.

### Benefits

- Higher signal range 0-100 kPa.  
Typical 10-60 kPa
- Built in upstream and downstream lengths
- May be fitted in any orientation
- Independent regulation and isolation functions
- Quarter turn isolation function
- "Quickset" digital precision handle
- Valve information easily visible when insulated
- Suitable for connecting to most steel, copper or plastic pipe systems
- Handle drilled to allow valve tagging and locking
- Accuracy +/-3%

The Ballorex Venturi uses a quarter turn ball valve for isolation and a needle valve for regulation in the same body. This unique design feature enables the valve to be used for isolation purposes without altering the setting on the regulation needle.

The Ballorex Venturi is easy to regulate, isolate install and operate.

All commissioning stations require a certain length of straight pipeline, excluding fittings, upstream from the valve to ensure correct flow conditions for accurate flow measurement. This length varies between five and ten pipe diameters depending on the manufacturers' recommended guidelines, eg if the valve size is 50mm, the length required is between 250mm and 500mm. The dimension is increased if the valve is fitted immediately after a pump. Some commissioning stations also require a downstream straight length.

The Ballorex Venturi technology means that, except for immediately after a pump, no straight lengths are required up or downstream. This also applies to the steel Ballorex Venturi 900XSL and 900SGL and is advantageous in a tight plant room.

The Ballorex Venturi is easy to use because the unique design enables it to be installed in any orientation, even with the test points facing down.

The DRV (double regulating valve), which does not include test points, may be used in the system for bypass duties.

### Comparison between headloss in fixed orifice and fixed Venturi orifice

#### Traditional orifice plate cartridge

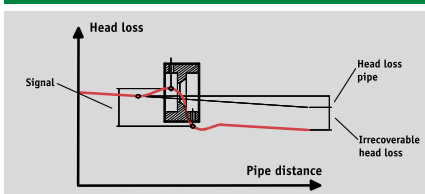

#### Orifice Venturi cartridge

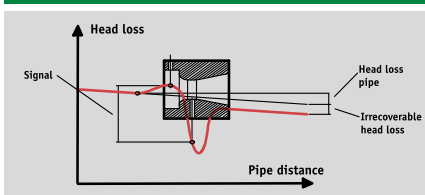

### Reliability

The Ballorex Venturi has been developed from proven technology by the Broen Valve Group – an ISO 9001 accredited company.

# Ballorex Venturi valves DN15 to DN50

## Ballorex Venturi DN15 to DN50

The Ballorex Venturi is available as a double regulating valve (DRV) or a commissioning station (FODRV) with a choice of compression or female BSP connections. Other connections are available – please contact us for details.

Both the Ballorex Venturi commissioning station and the Double Regulating Valve incorporate a characterised regulating needle combined with an isolation ball valve. The double regulating feature allows the valve to be isolated without movement of the set regulation point. The needle is adjusted to the required set point by using the allen key, which is supplied with the Ballorex Venturi valve.

### Commissioning station

The flow rate is measured using a fixed venturi orifice cartridge with test points inserted into the valve body. The functions are incorporated into a single fitting which contains the up and down stream lengths required for accurate flow readings except when installed within close proximity to a pump (when 5 x tube diameter of straight upstream pipeline is required). The commissioning valve produces a signal between 10–60 kPa. The valves are suitable for mounting in any orientation, including with the test points pointing down. The commissioning station has an accuracy of +/- 3 %.

### Double regulating valve

It is not possible to measure the flow through the valve.

### Cross section of Ballorex Venturi

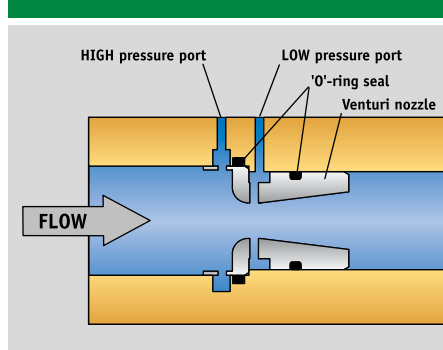

### The Venturi groove system

The Ballorex Venturi has been designed for installation in any orientation. This feature is possible due to the creation of a cylindrical chamber around the outside of the venturi cartridge and another chamber in the housing. Two pilot holes from the high and low pressure sides of the venturi feed the pressure differential in to the chambers, on the outside of which are located the test points. The pilot holes from the venturi to the chamber are positioned at 3 and 9 'o' clock positions when the valve is positioned upright. Therefore, should either pilot hole fill with debris (when positioned pointing down) the other will be pointing up allowing the signal to be measured.

### “Quickset” digital precision handle

To complement the high accuracy of the Ballorex Venturi the “Quickset” Digital Precision Handle is fitted to all commissioning stations and double regulating valves in sizes up to 54mm/2". With 100 individual positions and clear scales, the handle ensures easy and accurate flow rate setting even after the application of thermal insulation.

To set the regulating spindle an Allen key is inserted through the handle. This is rotated to increase or decrease the flow. Due to the unique construction using the integrated ball valve and separate regulating spindle the Ballorex Venturi can be isolated with a quarter turn rotation of the handle without moving the regulated point. This feature removes the need for a memory stop.

### Regulation

- Allen key operated (DN15-25 and 1½" to 1": 3mm, DN32-50 and 1¼" to 2":5mm)
- Two digit set point indication
- Digits are reflective to improve visibility
- Number of set points: 100

### Valve identification

All handles are labelled to identify valve size, Kvs value and Venturi cartridge type ie low flow, standard flow.

### Security

To prevent unauthorised isolation, the handle can be wired to the pipe in the open or closed position. Adjustment of the regulating needle can only be made with an allen key.

## Signal coefficients

**Kv:** The flow of water through a flow measurement device or double regulating valve at a temperature between 5°C and 40°C measured in cubic metres per hour, that will induce a pressure loss of 1 bar.

**Kvs:** The flow of water through a fixed flow measurement device at a temperature between 5°C and 40°C measured in cubic metres per hour, that will induce a differential pressure, or a signal of 1 bar across the tapping points.

The Kvs is printed on the handle of the Ballorex Venturi.

## Ballorex Venturi static data DN15 to DN50

### FLOW RANGES BALLOFIX VENTURI PRESS AND PUSH CONNECTIONS

Valve size	Connection size	Description	Flow (l/s)	Signal (kPa)
DN15	15mm	Low flow	0.010-0.074	1-55
		Standard flow	0.062-0.148	9-55
		High flow	0.140-0.330	10-56
DN15	18mm	Low flow	0.010-0.074	1-55
		Standard flow	0.062-0.148	9-55
		High flow	0.140-0.330	10-56
DN20	15mm	Low flow	0.062-0.148	9-55
		Standard flow	0.138-0.325	10-56
		High flow	0.260-0.600	10-54
DN20	18mm	Low flow	0.062-0.148	9-55
		Standard flow	0.138-0.325	10-56
		High flow	0.260-0.600	10-54
DN20	22mm	Low flow	0.062-0.148	9-55
		Standard flow	0.138-0.325	10-56
		High flow	0.260-0.600	10-54
DN25	28mm	Standard flow	0.258-0.603	10-54
		High flow	0.540-1.250	10-56
DN32	35mm	High flow	0.540-1.250	10-56
DN40	42mm	High flow	0.810-1.880	10-54
DN50	54mm	High flow	1.520-3.510	10-55

### FLOW RANGES BALLOFIX VENTURI THREADED AND COMPRESSION CONNECTIONS

Valve size	Connection size	Description	Flow (l/s)	Signal (kPa)
DN15	1/2"	Low flow	0.010-0.074	1-55
		Standard flow	0.062-0.148	9-55
		High flow	0.140-0.330	10-56
DN20	3/4"	Low flow	0.062-0.148	9-55
		Standard flow	0.138-0.325	10-56
		High flow	0.260-0.600	10-54
DN25	1"	Standard flow	0.258-0.603	10-54
		High flow	0.540-1.250	10-56
DN32	1 1/4"	High flow	0.540-1.250	10-56
DN40	1 1/2"	High flow	0.810-1.880	10-54
DN50	2"	High flow	1.520-3.510	10-55

### FLOW RANGES (BS 7350) – BALLOFIX VENTURI – DRV

Valve size	Connection size	Description	Kv (m3/h)
DN15	1/2" BSP	Low flow	1.62
		Standard flow	2.11
DN20	3/4" BSP	Low flow	4.26
		Standard flow	4.81
DN25	1" BSP	Standard flow	9.94
DN32	1 1/4" BSP	High flow	13.3
DN40	1 1/2" BSP	High flow	23.3
DN50	2" BSP	High flow	35.3

# Ballorex Steel Venturi Commissioning valves DN65 to DN300

## Steel Ballorex Venturi DN65 to DN300

The steel Ballorex Venturi is available as a commissioning station (FODRV) with flanged connections, as a regulating valve or as a fully lugged double regulating valve (DRV).

Both the Ballorex Venturi commissioning station and the Double Regulating Valve incorporate a characterised regulating butterfly valve with fixed liner. All steel valves in the Ballorex Venturi range are operated by means of a manual gear with memory stop, which is used to allow operation only between set point and closed position. This double regulating feature provided by a memory stop in the gear box allows the disc setting to be locked in position (using an Allen key) and guarantees it will return to the exact same position after isolation.

### Commissioning station

The flow rate can be measured using a fixed venturi orifice steel pipe with test points. The commissioning station is suitable for mounting in any orientation with the venturi test points positioned between 8 and 4 o'clock.

### Regulating valves (DRV type)

It is not possible to measure the flow through the valve. The butterfly valve is suitable for mounting in any direction.

### Standard pattern

The up and down stream lengths are included. However when the valve is installed within close proximity to a pump the upstream straight pipe must be 10 x tube diameter.

### Extended pattern

The assembly incorporates the up and down stream lengths required for highest accuracy in flow measurement, except when installed within close proximity to a pump, when 5 x tube diameter straight pipe is required upstream.

### Flow rates

The table below indicates the flow rates of steel Ballorex Venturi valves.

<i>FLOW RANGES (BS 7350) STEEL BALLOREX VENTURI</i>		
<i>Nominal size</i>	<i>Flow (l/s)</i>	<i>Signal (kPa)</i>
DN65	3–7	8–45
DN80	6–15	9–55
DN100	11–26	9–53
DN125	17–40	10–57
DN150	24–57	6–35
DN200	42–100	7–38
DN250	67–157	8–43
DN300	94–226	5–29



### Tube and pipe compatibility

Ballorex Venturi valves with compression ends can be used with copper tube to BS EN 1057, and, in sizes up to 28mm with PEX and PB pipe (with appropriate liner). Ballorex Venturi valves with threaded ends can be used with steel tube to BS 1387 and male iron connection fittings. Steel Ballorex Venturi valves should be assembled with the appropriate flanges and tube. For full details of tube and pipe specifications, please see pages 27 and 28.

### Calculations

#### Pressure loss

$$Dp_{FODRV} = \Delta P \times \text{Loss factor}$$

where

$Dp_{FODRV}$  = Head/pressure loss created by FODRV (kPa)

$\Delta P$  = signal (kPa)

Loss factor for fully open valve – See values in the product tables

#### Calculation of flowrate, signal and size

$$Q = \frac{Kvs \times \sqrt{\Delta p}}{36} \text{ or } \Delta p = \left(36 \frac{Q}{Kvs}\right)^2$$

#### Example

Given: Flow (Q) = 0,11 l/s  
 Pipe size = 15mm  
 E.g => Ballorex Venturi DN15H female with Kvs = 0.746 and loss factor = 0.24

Wanted: Signal ( $\Delta p$ ) and pressure loss ( $Dp_{fodrv}$ )

Signal ( $\Delta p$ ): 
$$\Delta p = \left(36 \frac{0.11}{0.746}\right)^2$$
  
 =>Signal = 28.2kPa

Pressure loss:  $Dp_{FODRV} = 28.2 \times 0.24$  (kPa)  
 = 6.76  
 =>Pressure loss = 6.76 kPa

### Typical installation

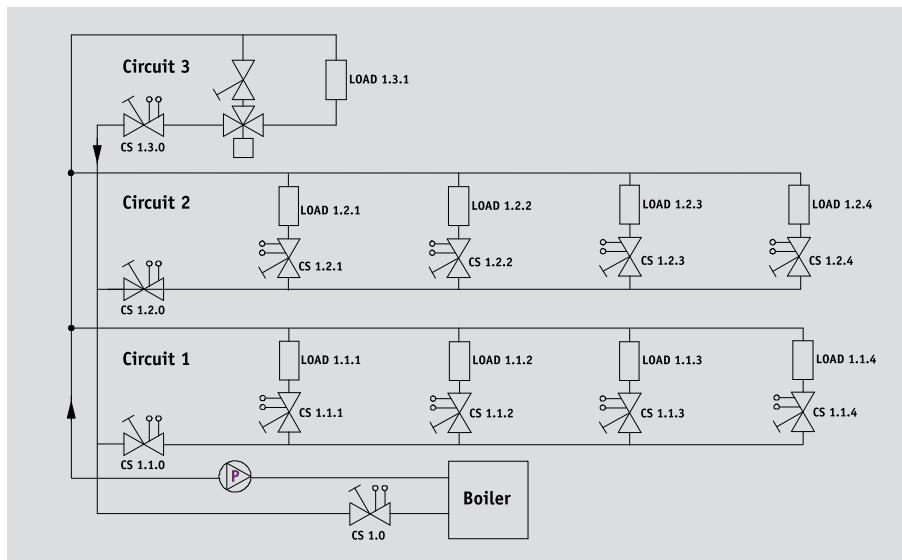

### Accessories

#### Test point inserts

Test point inserts are fitted as standard to all Ballorex Venturi commissioning stations, and have a weight of 26g. The integral EPDM seals are resistant to glycol, alcohol, phosphates, esters, ketones and detergents.

#### Extension tube

Extension tubes are available to allow valves to be insulated to a thickness of 50mm without the test points being covered.

Up and down stream lengths are not required for DN 15-300 – only after direct connection to a pump.



# Ballorex Dynamic Commissioning valves DN15 to DN50 technical specification

The Ballorex Dynamic valve provides a combined pressure independent flow limiter and control valve in one body.

This innovative new range of dynamic valves operate independently of changes in system pressure in heating and cooling water systems within commercial applications.

At the heart of the Ballorex Dynamic is an integrated, in line fixed orifice Venturi. This allows direct verification of pre-setting and actual flow in operation, taking the guess work out of measuring the flow further down stream to verify or adjust the setting.

The Ballorex Dynamic carries with it many of the benefits of the Ballorex Venturi Static valve:

- Direct flow measuring
- Measuring accuracy within +/-3%
- Easy valve selection
- Accurate and easy setting of maximum flow
- Installation can be done in any desired position
- Can be installed directly onto bends, reducers and flexible hoses
- Will save time, space and money.

**The features of the Ballorex Dynamic are:**

- Commissioning is no longer needed
- Operates independently from pressure changes
- Full control authority means perfect flow control
- Different inserts are colour coded and easily identified.

## DN15 to DN50 product range

**DN15L**

36–126 L/H (0.01 – 0.035 l/sec)

**DN15S**

108–540 L/H (0.03 – 0.15 l/sec)

**DN15H**

324–1440 L/H (0.09 – 0.4 l/sec)

- Other sizes available from January 2010



**BALLOREX DYNAMIC DN15–DN50 SPECIFICATION**

Temperature range	-20°C to 120°C
Pressure range	20–400ka
Measuring accuracy	+/- 3%
Pressure class	PN25
Valve stroke	3.5mm
3 modes of operation	1. Modulating valve with automatic flow limiter 2. On/off modulating control valve with automatic flow limiter 3. Automatic flow limiter
Suitable for:	Water, propylene or ethylene glycol mixture
Housing material	DZR Brass
Sealing material	EPDM
Stroke	3.5mm

# Ballorex Dynamic DN15 to DN50 installation options

## Automatic flow regulator

Without actuator the valve is an automatic flow limiter. With direct flow measuring the designed maximum flow is easily preset with a unique accuracy of +/- 3%. The Ballorex Dynamic will ensure that the maximum pre-set flow rate is not exceeded at any point.



## Press setting

### Pre-setting

The required flow rate is simply and easily adjusted on the underneath of the actuator.



## Know the flow with direct measuring

Ballorex Dynamic valve is unique compared to other dynamic valves offered in the market. It is the only valve having a built-in Venturi, with a fixed Kv-value allowing direct flow measurement using a flow meter.

The actual system flow can be checked and compared to the designed flow. There is therefore no longer any reason to assume that the flow is correct, it can now be verified.

With the direct flow measurement, commissioning documentation of actual flow rates can be provided. This is often required by legislation and recommended by design guides.

Accurate setting is easily done using a flow meter. Adjusting the required flow while monitoring the actual flow provides a very precise setting of the valve.

Finally the direct flow measurement can help in general maintenance of the system. Either in service checks or detecting and identifying system errors.

## Automatic flow regulator and control valves

Installed with an actuator the Ballorex Dynamic combines automatic flow limiter and 2-way control valve in one. With full control authority the valve reacts instantly and adjusts the flow as signalled by the Building Management System (BMS).



### Differential pressure controller

An integrated differential pressure valve maintains a constant differential pressure over the valve opening. In that way the required flow is kept constant regardless of pressure changes in the system.



### Full control authority

The actuator has 100% control authority and thus reacts promptly to the signal from the BMS and adjusts the flow accordingly.



# Ballorex Dynamic

## 902S Ballorex Venturi DZR dynamic valve – female threaded excluding actuator

Cat No.	Valve Size	Connection Size	Dimensions in mm			Weight kg	Flow Rate l/s	Order code
			A	B	C			
902SL	DN15	15mm	95	76	35	0.55	0.01 - 0.035	15230
902SS	DN15	15mm	95	76	35	0.55	0.03 - 0.15	15231
902SH	DN15	15mm	95	76	35	0.55	0.09 - 0.40	15232

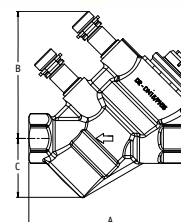

## PS902S Ballorex Venturi DZR dynamic valve – press-fit excluding actuator

Cat No.	Valve Size	Connection Size	Dimensions in mm			Weight kg	Flow Rate l/s	Order code
			A	B	C			
PS902SL	DN15	15mm	141	76	35	0.62	0.01 - 0.035	15282
PS902SS	DN15	15mm	141	76	35	0.62	0.03 - 0.15	15283
PS902SH	DN15	15mm	141	76	35	0.62	0.09 - 0.40	15284
PS902SL	DN15	18mm	141	76	35	0.62	0.01 - 0.035	15285
PS902SS	DN15	18mm	141	76	35	0.62	0.03 - 0.15	15286
PS902SH	DN15	18mm	141	76	35	0.62	0.09 - 0.40	15287

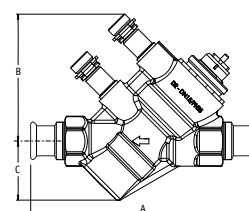

## PT902S Ballorex Venturi DZR dynamic valve – push-fit excluding actuator

Cat No.	Valve Size	Connection Size	Dimensions in mm			Weight kg	Flow Rate l/s	Order code
			A	B	C			
PT902SL	DN15	15mm	144	76	35	0.63	0.01 - 0.035	15288
PT902SS	DN15	15mm	144	76	35	0.63	0.03 - 0.15	15289
PT902SH	DN15	15mm	144	76	35	0.63	0.09 - 0.40	15290
PT902SL	DN15	18mm	144	76	35	0.66	0.01 - 0.035	15291
PT902SS	DN15	18mm	144	76	35	0.66	0.03 - 0.15	15292
PT902SH	DN15	18mm	144	76	35	0.66	0.09 - 0.40	15293

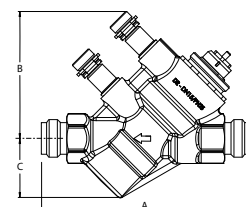

## Ballorex Dynamic

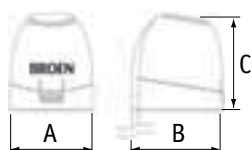

<b>BALLOREX DYNAMIC ACTUATOR SPECIFICATION – ACTUATOR ON/OFF</b>									
Cat No.	Valve Size	Dimensions in mm			Power Supply	Standard Position	Protection	Adaptor	Order Code
AT01	DN15	A	B	C	230v	Normally closed	IP54	M30 x 1.5	15280

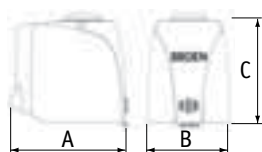

<b>BALLOREX DYNAMIC ACTUATOR SPECIFICATION – ACTUATOR MODULATING</b>										
Cat No.	Valve Size	Dimensions in mm			Power Supply	Control Voltage Input	Standard Position	Protection	Adaptor	Order Code
AE01	DN15	A	B	C	24v AC	0-10v DC	Normally closed	IP54	M30 x 1.5	15281

## 900S Ballorex Venturi DZR commissioning valve (FODRV)

BS 7350 Threaded ISO228 parallel female

Cat No.	Size	Dimensions in mm				Weight kg	Kvs m3/h	Kv m3/h	Loss Factor	Order code
		A	B	C	D					
900SL	1/2" BSP	94	75	140	76	0.41	0.359	0.629	0.33	15006
900SS	1/2" BSP	94	75	140	76	0.41	0.746	1.620	0.21	15000
900SH	1/2" BSP	94	75	140	76	0.41	1.560	2.490	0.39	16404
900SL	3/4" BSP	100	75	144	79	0.41	0.746	1.430	0.27	15007
900SS	3/4" BSP	100	75	144	79	0.41	1.560	2.820	0.31	15001
900SH	3/4" BSP	100	75	144	79	0.41	2.950	5.720	0.27	16405
900SS	1" BSP	112	75	150	83	0.67	2.950	7.540	0.15	15002
900SH	1" BSP	112	75	150	83	0.67	6.010	12.100	0.25	15181
900SH	1 1/4" BSP	130	122	208	109	1.27	6.010	13.200	0.21	15003
900SH	1 1/2" BSP	140	122	213	113	1.66	9.200	22.000	0.17	15004
900SH	2" BSP	156	122	221	120	2.37	17.100	36.000	0.23	15005



## PS900S Ballorex DZR commissioning station (FODRV) – press ends

Cat No.	Valve Size	Connection Size	Dimensions in mm				Weight kg	Kvs m3/h	Kv m3/h	Loss Factor	Order code
			A	B	C	D					
PS900SL	DN15	15mm	138	75	162	76	0.49	0.359	0.629	0.33	15550
PS900SS	DN15	15mm	138	75	162	76	0.49	0.749	1.620	0.21	15551
PS900SH	DN15	15mm	138	75	162	76	0.49	1.560	2.490	0.39	15552
PS900SL	DN15	18mm	138	75	162	76	0.49	0.359	0.629	0.33	15553
PS900SS	DN15	18mm	138	75	162	76	0.49	0.749	1.620	0.21	15554
PS900SH	DN15	18mm	138	75	162	76	0.49	1.560	2.490	0.39	15555
PS900SL	DN20	15mm	143	75	166	79	0.51	0.746	1.430	0.27	15556
PS900SS	DN20	15mm	143	75	166	79	0.51	1.560	2.820	0.31	15557
PS900SH	DN20	15mm	143	75	166	79	0.51	2.950	5.720	0.27	15558
PS900SL	DN20	18mm	143	75	166	79	0.51	0.746	1.430	0.27	15559
PS900SS	DN20	18mm	143	75	166	79	0.51	1.560	2.820	0.31	15560
PS900SH	DN20	18mm	143	75	166	79	0.51	2.950	5.720	0.27	15561
PS900SL	DN20	22mm	147	75	166	79	0.52	0.746	1.430	0.27	15562
PS900SS	DN20	22mm	147	75	166	79	0.52	1.560	2.820	0.31	15563
PS900SH	DN20	22mm	147	75	166	79	0.52	2.950	5.720	0.27	15564
PS900SS	DN25	28mm	165	75	177	83	0.88	2.950	7.540	0.15	15565
PS900SH	DN25	28mm	165	75	177	83	0.88	6.010	12.100	0.25	15566
PS900SH	DN32	35mm	188	122	237	109	1.62	6.010	13.200	0.21	15567
PS900SH	DN40	42mm	194	122	240	113	2.18	9.200	22.000	0.17	15568
PS900SH	DN50	54mm	243	122	265	120	3.38	17.100	36.000	0.23	15569

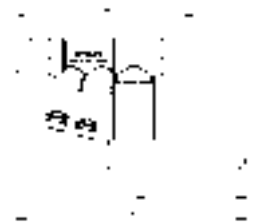

## Ballorex Venturi



### PT900S Ballorex Venturi DZR commissioning valve (FODRV)

Tectite push-fit ends

Cat No.	Valve Size	Connection Size	Dimensions in mm				Weight kg	Kvs m <sup>3</sup> /h	Kv m <sup>3</sup> /h	Loss Factor	Order code
			A	B	C	D					
PT900SL	DN15	15mm	143	75	162	76	0.48	0.359	0.629	0.33	15584
PT900SS	DN15	15mm	143	75	162	76	0.48	0.749	1.620	0.21	15585
PT900SH	DN15	15mm	143	75	162	76	0.48	1.560	2.490	0.39	15586
PT900SL	DN15	18mm	143	75	162	76	0.48	0.359	0.629	0.33	15587
PT900SS	DN15	18mm	143	75	162	76	0.48	0.749	1.620	0.21	15588
PT900SH	DN15	18mm	143	75	162	76	0.48	1.560	2.490	0.39	15589
PT900SL	DN20	15mm	143	75	166	79	0.52	0.746	1.430	0.27	15590
PT900SS	DN20	15mm	143	75	166	79	0.52	1.560	2.820	0.31	15591
PT900SH	DN20	15mm	143	75	166	79	0.52	2.950	5.720	0.27	15592
PT900SL	DN20	18mm	143	75	166	79	0.52	0.746	1.430	0.27	15593
PT900SS	DN20	18mm	143	75	166	79	0.52	1.560	2.820	0.31	15594
PT900SH	DN20	18mm	143	75	166	79	0.52	2.950	5.720	0.27	15595
PT900SL	DN20	22mm	149	75	166	79	0.52	0.746	1.430	0.27	15596
PT900SS	DN20	22mm	149	75	166	79	0.52	1.560	2.820	0.31	15597
PT900SH	DN20	22mm	149	75	166	79	0.52	2.950	5.720	0.27	15598
PT900SS	DN25	28mm	179	75	177	83	0.85	2.950	7.540	0.15	15599
PT900SH	DN25	28mm	179	75	177	83	0.85	6.010	12.100	0.25	15600
PT900SH	DN32	35mm	229	122	237	109	1.78	6.010	13.200	0.21	15601
PT900SH	DN40	42mm	251	122	240	113	2.40	9.200	22.000	0.17	15602
PT900SH	DN50	54mm	280	122	265	120	3.26	17.100	36.000	0.23	15603

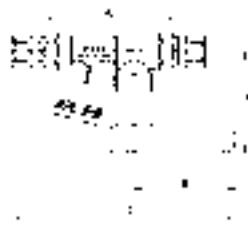

### 900SC Ballorex Venturi DZR commissioning station (FODRV) – compression

Cat No.	Valve Size	Connection Size	Dimensions in mm				Weight kg	Kvs m <sup>3</sup> /h	Kv m <sup>3</sup> /h	Loss Factor	Order code
			A	B	C	D					
900SCL	DN15	15mm	99	75	164	76	0.54	0.359	0.629	0.33	15015
900SCS	DN15	15mm	99	75	164	76	0.54	0.746	1.620	0.21	15009
900SCH	DN15	15mm	99	75	164	76	0.54	1.560	2.490	0.39	16406
900SCL	DN20	22mm	105	75	170	79	0.72	0.746	1.430	0.27	15016
900SCS	DN20	22mm	105	75	170	79	0.72	2.950	5.720	0.27	15010
900SCH	DN20	22mm	105	75	170	79	0.72	1.560	2.820	0.31	16407
900SCS	DN25	28mm	118	75	177	83	1.00	6.010	12.100	0.25	15011
900SCH	DN25	28mm	118	75	177	83	1.00	2.950	7.540	0.15	15183
900SCH	DN32	35mm	135	122	241	109	1.81	6.010	13.200	0.21	15012
900SCH	DN40	42mm	149	122	253	113	2.51	9.200	22.000	0.17	15013
900SCH	DN50	54mm	167	122	265	120	3.82	17.100	36.000	0.23	15014

### PS901S Ballorex Venturi DZR double regulating valve (DRV) – press ends

Cat No.	Valve Size	Connection Size	Dimensions in mm				Weight kg	Kvs m <sup>3</sup> /h	Kv m <sup>3</sup> /h	Loss Factor	Order code
			A	B	C	D					
PS901SL	DN15	15mm	101	75	126	76	0.31	-	1.62	-	15570
PS901SS	DN15	15mm	101	75	126	76	0.31	-	2.10	-	15571
PS901SL	DN15	18mm	101	75	126	76	0.31	-	1.62	-	15572
PS901SS	DN15	18mm	101	75	126	76	0.32	-	2.10	-	15573
PS901SL	DN20	15mm	105	75	128	79	0.39	-	4.26	-	15574
PS901SS	DN20	15mm	105	75	128	79	0.39	-	4.79	-	15575
PS901SL	DN20	18mm	105	75	128	79	0.39	-	4.26	-	15576
PS901SS	DN20	18mm	105	75	128	79	0.39	-	4.79	-	15577
PS901SL	DN20	22mm	109	75	128	79	0.40	-	4.26	-	15578
PS901SS	DN20	22mm	109	75	128	79	0.40	-	4.79	-	15579
PS901SS	DN25	28mm	128	75	140	83	0.68	-	12.80	-	15580
PS901SH	DN32	35mm	146	122	195	109	1.35	-	13.28	-	15581
PS901SH	DN40	42mm	170	122	198	113	1.77	-	23.30	-	15582
PS901SH	DN50	54mm	202	122	198	113	2.81	-	35.30	-	15583



### 901S Ballorex Venturi DZR double regulating valve (DRV) – female

Cat No.	Size	Dimensions in mm				Weight kg	Kvs m <sup>3</sup> /h	Kv m <sup>3</sup> /h	Loss Factor	Order code
		A	B	C	D					
901SL	1/2" BSP	57	75	104	76	0.23	-	1.62	-	15042
901SS	1/2" BSP	57	75	104	76	0.23	-	2.10	-	15036
901SL	3/4" BSP	62	75	106	79	0.29	-	4.26	-	15043
901SS	3/4" BSP	62	75	106	79	0.29	-	4.79	-	15037
901SS	1" BSP	75	75	113	83	0.47	-	12.80	-	15038
901SS	1 1/4" BSP	88	122	166	109	1.01	-	13.28	-	15039
901SS	1 1/2" BSP	98	122	171	113	1.24	-	23.30	-	15040
901SS	2" BSP	115	122	180	120	1.80	-	35.30	-	15041



## Ballorex Venturi

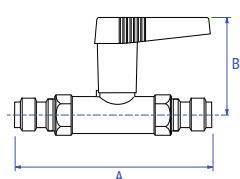

### PT901S Ballorex Venturi DZR double regulating valve (DRV) – push ends

Cat No.	Valve Size	Connection Size	Dimensions in mm				Weight kg	Kvs m <sup>3</sup> /h	Kv m <sup>3</sup> /h	Loss Factor	Order code
			A	B	C	D					
PT901SL	DN15	15mm	106	75	126	76	0.30	-	1.62	-	15604
PT901SS	DN15	15mm	106	75	126	76	0.30	-	2.10	-	15605
PT901SL	DN15	18mm	106	75	126	76	0.30	-	1.62	-	15606
PT901SS	DN15	18mm	106	75	126	76	0.30	-	2.10	-	15607
PT901SL	DN20	15mm	121	75	128	79	0.40	-	4.26	-	15608
PT901SS	DN20	15mm	121	75	128	79	0.40	-	4.79	-	15609
PT901SL	DN20	18mm	121	75	128	79	0.40	-	4.26	-	15610
PT901SS	DN20	18mm	121	75	128	79	0.40	-	4.79	-	15611
PT901SL	DN20	22mm	121	75	128	79	0.40	-	4.26	-	15612
PT901SS	DN20	22mm	121	75	128	79	0.40	-	4.79	-	15613
PT901SS	DN25	28mm	142	75	140	83	0.65	-	12.80	-	15614
PT901SH	DN32	35mm	187	122	195	109	1.52	-	13.28	-	15615
PT901SH	DN40	42mm	209	122	198	113	1.98	-	23.30	-	15616
PT901SH	DN50	54mm	239	122	198	113	2.69	-	35.30	-	15617

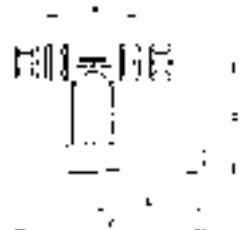

### 901SC Ballorex Venturi DZR double regulating valve (DRV) – compression

Cat No.	Size	Dimensions in mm				Weight kg	Kvs m <sup>3</sup> /h	Kv m <sup>3</sup> /h	Loss Factor	Order code
		A	B	C	D					
901SCL	15mm	62	75	128	76	0.37	-	1.62	-	15050
901SCS	15mm	62	75	128	76	0.37	-	2.10	-	15044
901SCL	22mm	67	75	132	79	0.51	-	4.26	-	15051
901SCS	22mm	67	75	132	79	0.51	-	4.79	-	15045
901SCS	28mm	81	75	140	83	0.80	-	12.80	-	15046
901SCS	35mm	93	122	199	109	1.55	-	13.28	-	15047
901SCS	42mm	107	122	211	113	2.12	-	23.30	-	15048
901SCS	54mm	126	122	224	120	3.25	-	35.30	-	15049



### 900XS Ballorex Venturi steel commissioning station (FODRV) – flanged

Cat No.	Valve Size	Dimensions in mm				No. of Holes	Weight kg	Kvs m <sup>3</sup> /h	Kv m <sup>3</sup> /h	Loss Factor	Order code
		A	B	C	D						
<b>Standard pattern</b>											
900XSS	DN65	182	185	285	100	4	13.3	37.4	78.2	0.23	15028
900XSS	DN80	249	200	295	100	8	16.2	72.9	169	0.19	15029
900XSS	DN100	325	220	310	160	8	23.0	129	360	0.13	15030
900XSS	DN125	341	250	325	160	8	30.0	190	502	0.14	15031
900XSS	DN150	354	285	340	160	8	36.0	348	1010	0.12	15032
900XSS	DN200	378	340	430	200	12	55.0	586	1910	0.09	15033
900XSS	DN250	411	405	465	200	12	78.0	861	2540	0.11	15034
900XSS	DN300	465	460	535	250	12	105	1513	4850	0.10	15035
<b>Extended pattern</b>											
900XSL	DN65	455	185	285	100	4	16.8	37.4	78.2	0.23	15023
900XSL	DN80	570	200	295	100	8	22.0	72.9	169	0.19	15024
900XSL	DN100	735	220	310	160	8	34.0	129	360	0.13	15025
900XSL	DN125	865	250	325	160	8	47.0	190	502	0.14	15026
900XSL	DN150	1010	285	340	160	8	63.0	348	1010	0.12	15027

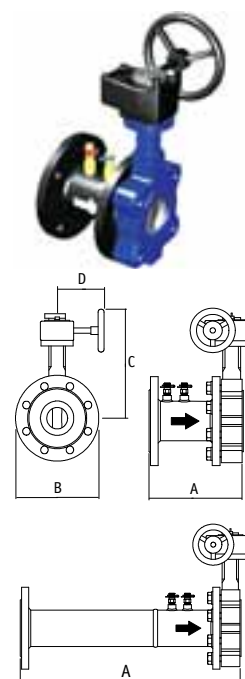

### 901XS Ballorex Venturi steel double regulating valve (DRV) – flanged

Cat No.	Valve Size	Dimensions in mm				No. of Holes	Weight kg	Kvs m <sup>3</sup> /h	Kv m <sup>3</sup> /h	Loss Factor	Order code
		A	B	C	D						
901XS	DN65	45	185	285	100	4	6.1	–	148	–	15056
901XS	DN80	46	200	295	100	8	6.3	–	237	–	15057
901XS	DN100	52	220	310	160	8	10.6	–	603	–	15058
901XS	DN125	55	250	325	160	8	12.6	–	888	–	15059
901XS	DN150	56	285	340	160	8	14.1	–	2341	–	15060
901XS	DN200	60	340	430	200	12	23.2	–	2845	–	15061
901XS	DN250	68	405	465	200	12	33.7	–	4549	–	15062
901XS	DN300	78	460	535	250	12	48.7	–	7761	–	15063

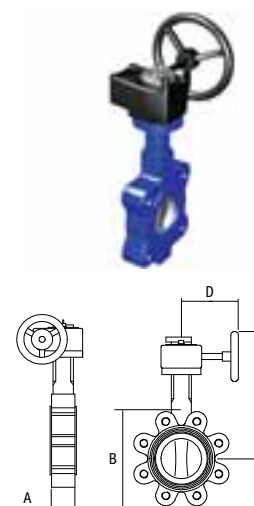

## Ballorex Venturi

# 2

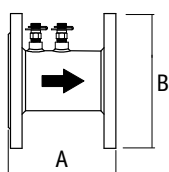

### 900RM Venturi metering station DN65–DN300 (short pattern)

Cat No.	Size	Dimensions in mm				Weight kg	Kvs m <sup>3</sup> /h	Kv m <sup>3</sup> /h	Loss Factor	Order code
		A	B	C	D					
900RMS	DN65	137	185	–	–	7.20	37.4	78.2	0.23	15843
900RMS	DN80	203	200	–	–	9.90	72.9	169	0.19	15844
900RMS	DN100	273	220	–	–	12.40	129	360	0.13	15845
900RMS	DN125	286	250	–	–	17.40	190	502	0.14	15846
900RMS	DN150	298	285	–	–	21.90	348	1010	0.12	15847
900RMS	DN200	318	340	–	–	31.80	586	1910	0.09	15848
900RMS	DN250	343	405	–	–	44.30	861	2540	0.11	15849
900RMS	DN300	387	460	–	–	56.30	1513	4850	0.10	15850

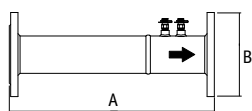

### 900RML Venturi metering station DN65–DN150 (long pattern)

Cat No.	Size	Dimensions in mm				Weight kg	Kvs m <sup>3</sup> /h	Kv m <sup>3</sup> /h	Loss Factor	Order code
		A	B	C	D					
900RML	DN65	410	185	–	–	10.70	37.4	78.2	0.23	15851
900RML	DN80	524	200	–	–	15.70	72.9	169	0.19	15852
900RML	DN100	683	220	–	–	23.40	129	360	0.13	15853
900RML	DN125	810	250	–	–	34.40	190	502	0.14	15854
900RML	DN150	956	285	–	–	48.90	348	1010	0.12	15855

## Insulated valve jackets

Insulating all system pipework and valves is of paramount importance in ensuring the system is optimised for energy consumption. Valves due to their shape are difficult to insulate being free to isolate and commission.

The Ballorex Venturi jackets are custom moulded to ensure a superior level of insulation whilst maintain a good vapour seal and permit better operation and commissioning duties.

NB. It is recommended on chilled water applications to apply a bead of silicone sealer to joint faces to maintain the vapour seal.

### Features

- Precisely moulded to the contours of the valves (DN15 to DN50) to ensure maximum insulative properties and access to connections
- Permits the valve to be commissioned once insulated by removal and replacement of a separate test point cap
- Allows the valve to be isolated without messy removal of the insulation.



### BALLOREX VENTURI INSULATION JACKET SPECIFICATION

Application	Insulation of Ballorex Venturi balancing valves in heating and cooling installations
Thermal conductivity	0,039W/mK
Max operating temperature	110°C
Min operating temperature	0°C (-8°C when all joints are sealed)
Material	Expanded Polypropylene (EPP), CFC-free
Volume weight	35 g/l
Fire resistance	Approved for fire resistance class B2 according to DIN 4102

### BALLOREX VENTURI INSULATION JACKET DIMENSIONS

Description	Dimensions in mm			Order code
	A	B	C	
Ballorex Venturi insulation jacket DN15	92	112	70	15250
Ballorex Venturi insulation jacket DN20	98	118	75	15251
Ballorex Venturi insulation jacket DN25	110	124	80	15252
Ballorex Venturi insulation jacket DN32	128	133	94	15253
Ballorex Venturi insulation jacket DN40	138	140	100	15254
Ballorex Venturi insulation jacket DN50	153	152	118	15255



## Introduction to Ballorex Modular

Ballorex Modular is a bespoke system made up of a variety of interlinked multifunctional valves and components manufactured from DZR brass. These are assembled into a complete unit that allows connection, regulation, isolation, flushing and draining.

Connections are made via female BSP, Tectite Pro or compression joints to the main pipework system; and via compression fittings – suitable for copper or multilayer pipe systems – to the terminal unit.

### Advantages of Ballorex Modular

The primary advantage of the Ballorex Modular system is its ability to be supplied in a wide variety of configurations in line with the specifiers' particular needs. Any component combination can be requested, and will be assembled specifically to meet individual requirements.

Other advantages of Ballorex Modular include:

#### Operational capabilities

- Can carry out any water flow control function required by a terminal unit – forward flush, bypass or backflush.
- The flow rate can be adjusted and set through the Ballorex Venturi commissioning valve.

#### Installation

- Installation planning is straightforward as all functions are contained within one unit.
- Requires no on-site or in situ adaptation prior to installation.
- A compact system, due to the valves' multifunctional capabilities and the ability to specify the flow and return centre spacing.



#### Maintenance and practicalities

- Valves with extended spindles contain a unique integral non-rotating outer spindle. This ensures that the vapour seal is maintained once insulation is applied and the valve opened or closed.
- Ball valve handles are colour coded red or blue to indicate heating or chilled water respectively.
- Colour coded test points throughout the unit allow temperature and pressure measurements to be taken.
- Strainers can easily be removed without the need to drain water from the installation.

### Ballorex Modular components

Each Ballorex Modular system is made up of a number of components, each with a particular function. Following specification these components are factory configured, tested and packaged as a complete unit.

### Tube and pipe compatibility

Ballorex Modular valves can be used with copper tube to BS EN 1057, carbon steel tube to DIN 2394/NEN 1982, steel tube to BS 1387 and multilayer tube as indicated in column I opposite.

### Installation

Each Ballorex Modular unit is supplied pre-assembled or with the specified individual components for self-assembly. Joining instructions can be made available from our technical department.

### Pre-commissioning

Pre-commissioning the Ballorex Modular system can be carried out in three simple steps – bypass operation, forward flush operation and backflush operation. Together, these flushing operations clear any debris which could have potentially entered the system during its assembly (refer to the adjacent illustrations and handle positions).

The strainer basket will need to be emptied of debris following prolonged use of the forward flush operation. However, an in-built design feature means this is not necessary for the backflush operation.

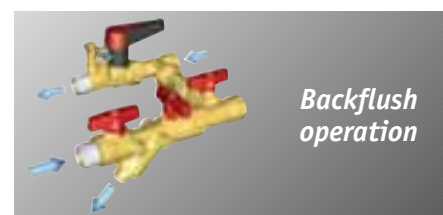
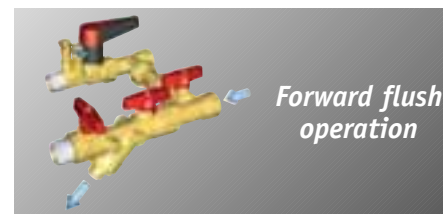
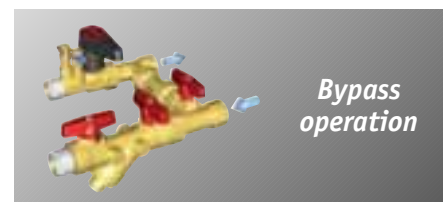
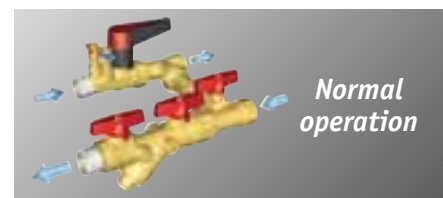

## Ballorex Modular specification options

### Ballorex Modular specification options

Simply select the required components from left to right. The corresponding codes will make up the unique order references as illustrated.

Column A B C D E F G H I  
Option 43 733 E 1-L L 0 0 26

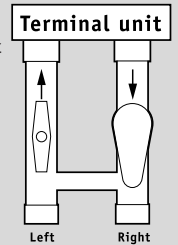
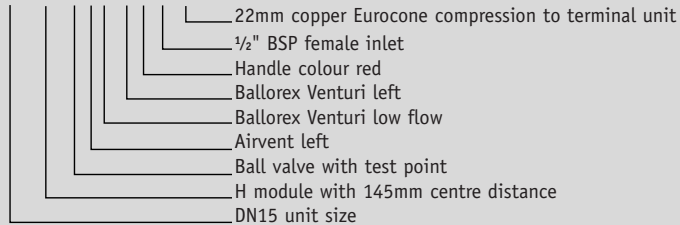

A Size	B H module	C Valve module	D Accessory module	E Ballorex Venturi	F Venturi left/right	G Handle colour	H Pipework connections	I Terminal unit connections
43 DN15	730 H module 99mm	C Ball valve	0- None	L Low flow	L Left	0 Red	0 1/2" BSP female	23 15mm copper Eurocone compression
44 DN20	731 H module 145mm	D Ball valve with extended spindle	1- Airvent left	S Standard flow	R Right	1 Blue	1 3/4" BSP female	26 22mm copper Eurocone compression
53 ABV DN15	735 H module 99mm hanger extension left	E Ball valve with test point	2- Test point left	H High flow			2 15mm Tectite Pro	31 3/4" male flat face
54 n-DN20	736 H module 145mm hanger extension left	F Ball valve with test points and extended spindles	3- Drain left				3 22mm Tectite Pro	59 15mm Tectite Pro
63 ABV M DN15	740 H module 99mm hanger extension right	G Ball valve with extended test points and extended spindles	4- Airvent right				6 15mm Press end	60 22mm Tectite Pro
73 ABV M O DN15	741 H module 145mm hanger extension right	H Y-Strainer	5- Test point right				7 22mm Press end	
	745 H module 99mm hanger extension both	I Y-Strainer with extended spindles	6- Drain right				8 18mm Press end	
	746 H module 145mm hanger extension both	J Y-Strainer with test points	7- Airvent both					
		K Y-Strainer with test points and extended spindles	8- Test point both					
		L Y-Strainer with extended test points and extended spindles	9- Drain both					

The exploded photograph below illustrates a typical Ballorex Modular combination. The basic H format is always retained and can be customised according to particular system design requirements. Where alternative components are available, options are illustrated to demonstrate the high level of flexibility provided by this system.

## H module



### Centre distances

For maximum flexibility any one of five different centre extensions can be selected to suit the flow and return pipework centre spacing. The following pipework centre spacings are available; 99mm, 145mm.

### Hanger extensions

Optional hanger extensions (with a set length of 110mm) can be used on either side of the unit when there is a requirement for additional support.

### Connections to main

The flow and return pipework connections are selected from the following options: female BSP in 1/2" and 3/4", Tectite Pro and in 15mm, 18mm and 22mm.

### Ball valve

The H module quarter turn ball valve is available with either blue or red handles and with standard or extended spindles.

## Size

The size is determined by the internal diameter of the Ballorex Venturi and is available in either DN15 or DN20 nominal diameter (flow rate specified opposite, under the "Ballorex Venturi Valve" section).

## Valve module

### Options

The valve module is available as either a quarter turn ball valve or a Y-Strainer.

### Ball valve

The quarter turn ball valve includes a drain off facility and can be selected with either red or blue handles with a further option for extended spindles. Test points can be added and extended if required.

### Y-Strainer

The Y-Strainer is available with red or blue handles which can be closed to prevent water loss when cleaning the strainer. Extended spindles are available for use with the handles. The Y-Strainer contains an integral stainless steel mesh of 0.8mm diameter. The addition of test points on either side of the strainer provides an easy method of measuring the pressure differential and determine whether it is blocked. Test points can also be extended if required.

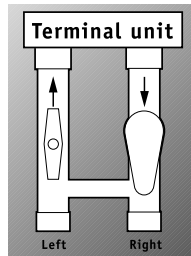

### Modular orientation

## Ballorex Venturi valve

The unique Ballorex Venturi commissioning valve is the key component within the module and precisely measures and regulates the flow.

### Flow specifications

Ballorex Venturi commissioning valves are available in ultra low flow, low flow and standard flow options.

### Left hand or right hand options

The Ballorex Venturi can be positioned on either side of the unit according to the requirements of the system. See diagram above for orientation definition.



## Hanger extension

The hanger extension is specified as a component of the H module.

## Connections to terminal unit



For connecting to the terminal unit, copper Eurocone compression Tectite Pro or male flat face ends can be selected.

## Accessory module

The accessory module is optional and provides the following additional features on one or both sides of the system if required: test point, drain off facility or airvent.



## Ballorex Venturi and Modular performance

### Ballorex Venturi

Ballorex Venturi commissioning valves perform to the following working temperatures and pressures. The working temperature and pressure is dictated by the component with the lowest performance rating, so for example a Ballorex Venturi (compression ends), connected with PEX or PB pipe would perform to a lower level than the figures indicated below for copper tube. Ballorex Venturi valves are designed and manufactured to Article 3, Section 3, to Sound Engineering Practice (S.E.P.) under the P.E.D.

#### BALLOREX VENTURI (COMPRESSION) VALVE PERFORMANCE WHEN CORRECTLY ASSEMBLED WITH COPPER TUBE TO BS EN 1057

Size	Service temperature	
	Min	Max
15mm to 54mm	-1°C	120°C
	5 bar	5 bar

#### BALLOREX VENTURI PERFORMANCE (FEMALE BSP CONNECTIONS), WHEN CORRECTLY ASSEMBLED WITH THE APPROPRIATE UNION FITTINGS AND TUBE (-20 TO 120° AT 25 BAR PRESSURE)

Size	Service temperature			
	Min	100°C	120°C	Max
1/2" to 2"	-1°C	20 bar	20 bar	16 bar
		16 bar	16 bar	16 bar

#### BALLOREX VENTURI STEEL VALVE PERFORMANCE (FLANGED CONNECTIONS) WHEN CORRECTLY ASSEMBLED WITH APPROPRIATE FITTINGS/FLANGES AND TUBE (-20 TO 120° AT 16 BAR PRESSURE)

Size	Service temperature	
	Min	Max
65mm to 300mm	-1°C	120°C
	16 bar	16 bar

#### BALLOREX VENTURI TEST POINT PERFORMANCE WHEN CORRECTLY ASSEMBLED (-20 TO 120° AT 35 BAR PRESSURE)

Size	Service temperature		
	Min	60°C	Max
All sizes	-1°C	69 bar	34 bar

### Test pressures

Test pressures for all Ballorex Venturi valves comply with ISO 5208: 1993 E. For Ballorex Venturi in sizes 15mm to 54mm and 1/2" to 2", both shell, seal and spindle perform at 6 bar (gas). For Steel Ballorex Venturi in sizes 65mm to 300mm, the shell performs at 24 bar hydrostatically.

### Ballorex Modular

The working temperature and pressure performance of Ballorex Modular is dependent on the connection configuration selected.

The tables below indicate the relevant working temperatures and pressures of Ballorex Modular and the various connection options. In all instances, the working temperature and pressure capabilities of the connecting pipework should also be considered, by referring to the relevant manufacturers specifications.

Ballorex Modular contains a Ballorex Venturi commissioning valve. These are designed and manufactured to Article 3, Section 3, to Sound Engineering Practice (S.E.P.) under the P.E.D.

The performance of the Ballorex Modular unit is dictated by the part – the unit itself, the connections or the pipework – with the lowest performance rating.

### Inlet connections performance

The following Tables 5-7 indicate the performance of Ballorex Modular inlet connections.

#### TECTITE PRO CONNECTION PERFORMANCE (-20 TO 120° AT 16 BAR PRESSURE)

Size	Service temperature			
	Min	30°C	65°C	Max
15mm, 22mm	-24°C	20 bar	20 bar	16 bar
		16 bar	16 bar	10 bar

#### COMPRESSION CONNECTION PERFORMANCE

Size	Service temperature			
	Min	30°C	90°C	Max
15mm, 22mm	-15°C	20 bar	20 bar	10 bar
		10 bar	10 bar	7 bar

### Performance ratings

In all instances, the working temperature and pressure is dictated by the component with the lowest performance rating. An example for Ballorex Modular is given below:

Configuration: A Ballorex Modular unit with a BSP female inlet connection to the pipework end, and a copper Eurocone connection to the terminal unit end, jointed to copper tube to BS EN 1057.

The unit would perform to the component with the lowest performance rating. For operation at 110°C this would be the female BSP inlet, with a performance of 6 bar. However, for operation at 30°C it would be the copper Eurocone connection, with a performance of 10 bar.

#### BSP FEMALE CONNECTION PERFORMANCE

Size	Service temperature			
	Min	30°C	65°C	Max
1/2", 3/4"	-40°C	16 bar	16 bar	10 bar
		10 bar	10 bar	6 bar



## Terminal unit connections performance

Multilayer Eurocone and copper Eurocone compression connections perform as shown in Table 1 below. This performance may be limited by the exact pipe used – please check with the pipe manufacturer.

<b>MULTILAYER AND COPPER EUROCONC CONNECTION PERFORMANCE</b>		
Size	Service temperature	
	Min	Max
	-1°C	130°C
All sizes	10 bar	10 bar

Male flat face connections perform as shown in Table 2 below. However, the performance of the component used to connect the flat face connector to the pipework should also be considered.

<b>MALE FLAT FACE CONNECTION PERFORMANCE</b>				
Size	Service temperature			
	Min	30°C	65°C	Max
	-40°C			110°C
3/4"	16 bar	16 bar	10 bar	6 bar

## Test pressures

Test pressures for all Ballorex Modular valves comply with ISO 5208:1993E.

## Pressure Equipment Directive (P.E.D.)

From 30th May 2002 most pressure equipment and assemblies on the market in the United Kingdom must comply with the Pressure Equipment Directive (P.E.D.) 1999. Selected Ballorex valves are classified under the P.E.D. – details are given in the main text.

For a detailed explanation of the P.E.D. visit our website [www.pegleryorkshire.co.uk](http://www.pegleryorkshire.co.uk).

## Antifreeze

For products used in water systems, working temperatures of less than 4°C can only be achieved if antifreeze is added to the system. Antifreeze should not be added to potable water systems.

## Quality and guarantees

Pegler Yorkshire operates a Quality Management System for the development, manufacture and supply of fittings, tube, valves and accessories which complies with the requirements of BS EN ISO 9001: 2000.

### Guarantees

*Our policy of continuously and rigorously testing Ballorex products means we are confident they will give you years of trouble free service. To demonstrate the total confidence we have in our products and our commitment to customer service, all Ballorex valves carry extensive guarantees against manufacturing defects when installed in accordance with our instructions on specified tube materials and applications, as shown in the table below.*

<b>BALLOREX VALVES GUARANTEES WHEN CORRECTLY ASSEMBLED WITH STATED TUBES AND PIPES</b>	
Valve	Length of guarantee
Ballorex Venturi	5 years
Ballorex Modular	5 years

We at Pegler Yorkshire are dedicated to designing, developing and manufacturing products of the highest quality. We are members of numerous standards committees and take an active part in their development. Ballorex valves all comply with the relevant British, European and International standards and approvals. The Ballorex range meets the following standards:

## Ballorex Venturi

### **Ballorex Venturi sizes 15mm to 54mm – compression ends**

**BS EN 1254 Part 2** Specification for copper and copper alloy fittings with compression ends for copper tubes.

### **Ballorex Venturi sizes 1/2" to 2" – female threaded ends and test points**

**ISO 7/EN 10226-1** (formerly BS 21/ISO 7) Specification for tubes and fittings where pressure-tight joints are made on the threads (metric dimensions).

### **Steel Ballorex Venturi – flange connections**

**BS EN 1092-1** (formerly BS 4504-3.1) Flanges and their joints. Circular flanges for pipes, valves, fittings and accessories, PN designated. Steel flanges.

## Ballorex Modular

### **Ballorex Modular – compression ends**

**BS EN 1254 Part 2** Refer to Ballorex Venturi.

### **Ballorex Modular – female threaded ends**

**ISO 7/EN 10226-1** (formerly BS 21/ISO7) Refer to Ballorex Venturi.

## Ballorex Venturi

The materials used in Ballorex Venturi valves are manufactured to the following specifications.

### **Ballorex Venturi sizes 15mm to 54mm and 1/2" to 2"**

**Venturi, ball, needle:** Chrome plated DZR brass to BS EN 12163 (CW602N). Specification for copper and copper alloy rod for general purposes.

**Valve body, spindle, compression rings, measure outlet:** DZR brass to BS EN 12163 (CW602N).

**Nuts:** Brass to BS EN 12163 (CW602N).

**Seals:** PTFE.

**"O" rings, rubber packings:** EPDM.

**Handles:** PA6.6 (Nylon Polyamide), 30% glass reinforced.

### **Steel Ballorex Venturi**

**Valve body:** Cast iron, fully lugged to ASTM A126 Class B.

**Venturi:** Carbon steel to St.37.

**Disk:** Stainless steel to ASTM A351 CFB.

**Shaft:** Stainless steel to ASTM 276 GR416.

**Seat:** EPDM, bonded.

**Drive pin:** Stainless steel to ASTM A276 GR316.

**Shaft seal:** Nitrile to NBR 1.

**Bearing:** Lubricated bronze to ASTM B62 (flanged) or ASTM B52 (grooved).

### **Test points**

**Body, retaining ring, cap, extension tube:** DZR brass to BS EN 12163 CZ 132.

**Seal and cap seal:** EPDM.

**Tie:** Polypropylene.

## Ballorex Modular

The materials used in Ballorex Modular are manufactured to the following specifications.

**Body, pipe and components, nipples, spindles, ball, draining tap, measure outlet:** DZR brass to BS EN 12163 CZ602N.

**Strainer:** AISI304, stitch size 0.8mm. tread 0.4mm.

**Seals:** PTFE.

**"O" rings, rubber packings:** EPDM.

**Handle (red/blue):** Die cast zinc BS1004A, ZA3

**Spindle extension:** PA6.6 (Nylon Polyamide), 10% glass reinforced; DZR brass to BS EN 12163 CZ602N.

**Handle screw:** Steel 4.8 electro-galvanised.

The Ballorex Modular valve system incorporates a Ballorex Venturi commissioning valve. The materials in a Ballorex Venturi valve are indicated opposite and above.

Ballorex valves are suitable for connecting to a variety of tubes and fittings – refer to the information for each particular product for details. There are specific standards the tube and pipe must achieve to be suitable for connection with Ballorex valves.

*Selected Ballorex valves are compatible with the following tubes and pipes. Refer to information on each product brand for further details.*

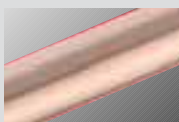

**COPPER TUBE**  
Copper tube to BS EN 1057.



**PEX AND PB PIPE**  
PEX pipe to BS 7291 Part 3 and PB pipe to BS 7291 Part 2 in sizes up to 28mm, in conjunction with the correct pipe support liner.

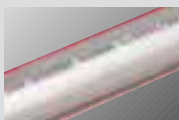

**STAINLESS STEEL TUBE**  
XPress Stainless System tube and other stainless steel tube to BS EN 10312, DVGW GW541.



**CARBON STEEL TUBE**  
XPress Carbon steel System tube and other carbon steel tubes to DIN 2394/NEN 1982.

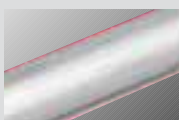

**STEEL TUBE**  
Steel tube to BS 1387.

*A small selection of other tubes and pipe are compatible with selected Ballorex products. In many cases the appropriate adaptor should be used. Contact us for specific information.*

### Copper tube

Copper tubes used with Ballorex valves must meet the requirements of BS EN 1057.

**BS EN 1057** Specification for copper and copper alloy – seamless round copper tubes for water (and gas) in sanitary and heating applications.

**BS EN 1057** includes specified temper conditions (material strength) expressed as an “R” number. Quite simply, the higher the number, the harder the material. As a result, tube diameter, wall thickness, length and the material temper must all be specified for full product designation.

**R220** Annealed condition with a tensile strength of 220N/mm<sup>2</sup> supplied in coils and suitable for connection by push-fit, capillary and compression fittings. Can be bent with suitable bending tools.

**R250** Half hard condition with a tensile strength of 250N/mm<sup>2</sup> supplied in straight lengths and suitable for connection by push-fit, press-fit, capillary and compression fittings. Can be bent with suitable bending tools.

**R290** Hard condition with a tensile strength of 290N/mm<sup>2</sup> supplied in straight lengths suitable for connection by push-fit, press-fit, capillary and non-manipulative compression fittings. Not suitable for bending.

### Stainless steel System tube

Yorkshire manufactures a thin-walled stainless steel System tube, available from our XPress range. It is compatible with a selection of our Ballorex products – see the individual product pages for details. Stainless steel tube is available in 6m straight lengths in sizes from 15mm to 108mm. The tube is manufactured from BS 316 S31/DIN 1.4401 stainless steel strip conforming to BS 10088 Part 2 and thanks to its thin-walled geometry, is stiff, lightweight and easy to handle.

### Carbon steel System tube

Yorkshire manufactures galvanised carbon steel System tube, available in two different specifications from our XPress range. It is compatible with a selection of our Ballorex products – see the individual product pages for details. Galvanised carbon steel System tube is available in sizes from 15mm to 108mm, and plastic (polypropylene) coated galvanised carbon steel System tube in sizes from 15mm to 54mm.

Galvanised carbon steel System tube is manufactured in accordance with DIN 2394/NEN 1982 from material with a very low carbon content and has a thin walled profile resulting in a lightweight easier to hand product. The galvanised coating (external only) has a minimum thickness of 7 microns and is thermally applied, providing a superior bond to the tube.

In sizes up to 28mm, carbon steel System tube is suitable for bending using proprietary bend formers.

### PEX and PB pipes

Selected Ballorex valves (see individual product pages for details) are compatible with PB and PEX pipes to BS 7291 Parts 2 and 3 respectively. One such PEX pipe is our Tectite System PEX.

<b>BS EN 1057 COPPER TUBE COMPATIBLE WITH BALLOREX VALVES</b>									
Outside diameter	Wall thickness (mm)								
	0.6	0.7	0.8	0.9	1.0	1.2	1.5	2.0	2.5
6mm	R220 R250	-	R220 R250	-	-	-	-	-	-
8mm	R220 R250	-	R220 R250	-	-	-	-	-	-
10mm	R250	R220	R220 R250	-	-	-	-	-	-
12mm	R250	-	R220 R250	-	-	-	-	-	-
15mm	-	R250	-	-	R220 R250	-	-	-	-
22mm	-	-	-	R250	-	R220 R250	-	-	-
28mm	-	-	-	R250	-	R220 R250	-	-	-
35mm	-	-	-	-	R290	R250	R250	-	-
42mm	-	-	-	-	R290	R250	R250	-	-
54mm	-	-	-	-	R290	R250	-	R250	-
67mm	-	-	-	-	-	R220 R250	-	R250	-
76mm	-	-	-	-	-	-	R290	R250	-
108mm	-	-	-	-	-	-	R290	-	R250

<b>STAINLESS STEEL TUBE SPECIFICATION</b>			
Outside diameter	316 System tube	Wall thickness	
		EN 10312 Table 1 GW541 Table 2 (formerly BS 4127)	EN 10312 Table 2 GW541 Table 3
15mm	0.5mm	0.6mm	1.0mm
18mm	0.6mm	0.7mm	1.0mm
22mm	0.6mm	0.7mm	1.2mm
28mm	0.8mm	0.8mm	1.2mm
35mm	1.0mm	1.0mm	1.5mm
42mm	1.0mm	1.1mm	1.5mm
54mm	1.0mm	1.2mm	1.5mm

<b>CARBON STEEL SYSTEM TUBE SPECIFICATION</b>		
Outside diameter	Wall thickness	
	Galvanised tube	Including plastic coating
15mm	1.2mm	2.2mm
18mm	1.2mm	2.2mm
22mm	1.5mm	2.5mm
28mm	1.5mm	2.5mm
35mm	1.5mm	2.5mm
42mm	1.5mm	2.5mm
54mm	1.5mm	2.5mm
76mm	2.0mm	-
89mm	2.0mm	-
108mm	2.0mm	-

<b>XPRESS SYSTEM TUBE BENDS</b>		
Size	Minimum Radii	
	Stainless steel System tube	Carbon steel System tube
15mm	52.5mm	30mm
18mm	72mm	36mm
22mm	88mm	44mm
28mm	112mm	56mm

Here are details of some of the specific design considerations it is important to take account of when designing and installing pipework systems containing systems containing Ballorex valves.

## Pipeline supports

Pipelines should always be constructed so that the joints are under neutral or compressive stress.

Clipping to support the assembled pipeline is essential and tube manufacturer's recommendations should be adhered to. Our Yorkshire integral solder ring range offers a wide range of pipe clips and brackets to ensure safe and secure installations. Pipe joist clips are also available, and are designed to protect pipework against accidental piercing when nailing or screwing down floorboards. For the maximum spacing of supporting brackets refer to Table 1.

## Stress corrosion cracking

Stress corrosion cracking (SCC) is a phenomenon that occurs occasionally with brass components. It is almost always introduced during installation, either from over-tightening of fittings or contamination from a corrosive substance.

The usual corrosive substance involved in SCC is ammonia or ammoniacal compounds, which can be found in cleaning fluids, refrigeration gases, sewage waste products, building materials, insulating materials (especially foams) and flame and smoke retarding treatments. An essential ingredient in the SCC process is moisture. Moisture on the fitting or pipework allows the corrosive substance to collect and become more

## Techniques for expansion stress relief

Horseshoe expansion link

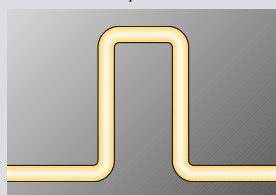

Offset

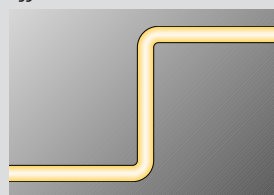

Crossover tee arrangement expansion loop

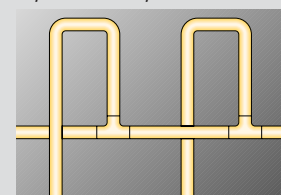

concentrated. This is a particular problem in chilled water installations, where insulating materials allow the condensed moisture to be retained and kept in close contact with the fitting surface.

Pegler Yorkshire Ltd does not recommend the use of highly stressed brass components in chilled water applications. Instead, we recommend fittings made from SCC resistant or immune materials, such as copper or gunmetal. Fittings from our XPress, Tectite, Yorkshire or Endex ranges are the preferred products for chilled water applications. If compression fittings are used then they should be assembled exactly in accordance with our published instructions and securely bound by a moisture barrier such as Densotape® to prevent moisture build up on the fitting.

The following installation practices should be adhered to when installing compression fittings in order to avoid SCC:

- Do not overtighten brass components.
- Use correctly fitting spanners.
- Use a drop or two of light oil on the threads of fittings of sizes 35mm and above.
- Avoid contaminating the threads or nuts with jointing compounds.
- Use parallel threaded adaptors to avoid stressing the female threaded ends.

Minimise the risk of contamination from a potential corrosive substance. Wrapping susceptible fittings in a vapour barrier or applying impermeable paints can be helpful in preventing contact with a corrosive substance.

## Insulation

For all installations, we recommend you adhere to the insulation requirements as specified by The Water Supply (Water Fittings) Regulations 1999. These can be downloaded from [www.hms.o.gov.uk](http://www.hms.o.gov.uk).

## Phenolic foam

When using rigid phenolic foam (or other thermal insulation) to lag pipework, always refer to the lagging manufacturer's fixing instructions. To avoid the risk of external corrosion of copper pipework the European Phenolic Foam Association recommends that such insulation products be installed with a moisture barrier, such as Densopaste or a plastic covering applied by the tube manufacturer. If you need to add a barrier product, we recommend that all Yorkshire fittings are fully installed and are completely coated before these are applied.

## Thermal movement

Thermal movement is a major consideration when designing and installing plumbing and heating systems, and should be taken into account. Pipework systems expand and contract with changes in temperature. If they are fixed too rigidly and their movement restricted the installation will be subject to stress. Stress concentrations between "fixed points" – typically found at radiators, valves and other fittings – should be avoided.

### MAXIMUM SPACING OF SUPPORT BRACKETS FOR INTERNAL FIXING OF COPPER TUBE TO BS EN 1057 R250 AND R290

Sizes	Wall thickness	Horizontal pitch	Vertical pitch
6mm	0.6mm	0.40m	0.60m
8mm	0.6mm	0.60m	0.90m
10mm	0.6mm	0.80m	1.20m
12mm	0.6mm	1.00m	1.50m
15mm	0.7mm	1.20m	1.80m
22mm, 28mm	0.9mm	1.80m	2.40m
35mm, 42mm	1.2mm	2.40m	3.00m
54mm	1.2mm	2.70m	3.00m
67mm	1.2mm	3.00m	3.60m
76mm, 108mm	1.5mm	3.00m	3.60m

### Tube and pipe expansion

Tubes and pipes compatible with selected Balleorex valves have linear expansion as detailed in the text and Tables 1 to 4 below.

- Copper has a coefficient in linear expansion of  $17 \times 10^{-6}/^{\circ}\text{C}$ . Refer to Table 1.
- Tectite System PEX has a coefficient of linear expansion of  $1.5 \times 10^{-4}/^{\circ}\text{C}$  at  $20^{\circ}\text{C}$  to approximately  $2.8 \times 10^{-4}/^{\circ}\text{C}$  at  $82^{\circ}\text{C}$ . Refer to Table 2.
- For details of the expansion of PB pipe refer to the manufacturers instructions.
- Stainless steel tube has a coefficient of linear expansion of  $16 \times 10^{-6}/^{\circ}\text{C}$ . Refer to Table 3.
- Carbon steel System tube has a coefficient of linear expansion of  $12 \times 10^{-6}/^{\circ}\text{C}$ . Refer to Table 4.

### Covered pipework

Making provision for thermal movement is vital where pipework of any material is installed under screed or plaster, or passes through brick or blockwork.

The preferred practice is to pass tubes and pipes through sleeves or conduits or to lay them in ducts surrounded by loose, non-rigid material such as vermiculite or glass wool. For further information, consult the standard BS 6700:1997.

### Chemicals

Some contracts may require the use of proprietary chemicals to cleanse and flush pipework before full commissioning. Balleorex valves are compatible with a selection of products – contact us to find out more.

### Correct anchoring

Always ensure the spur used to anchor the branch of a tee or connect to a radiator is long enough to allow normal thermal movement. Not doing this can lead to installation failure.

### Pipework accessibility

It's wise to take advice from the local water authority when it comes to pipework accessibility.

#### COPPER TUBE EXPANSION

Temperature change	Tube length							
	3m	4m	5m	6m	7m	8m	9m	10m
10°C	0.5mm	0.7mm	0.9mm	1.0mm	1.2mm	1.4mm	1.5mm	1.7mm
20°C	1.0mm	1.4mm	1.7mm	2.0mm	2.4mm	2.7mm	3.0mm	3.4mm
40°C	2.0mm	2.7mm	3.4mm	4.1mm	4.8mm	5.4mm	6.1mm	6.8mm
60°C	3.1mm	4.1mm	5.1mm	6.1mm	7.1mm	8.2mm	9.2mm	10.2mm
80°C	4.1mm	5.4mm	6.8mm	8.2mm	9.5mm	10.9mm	12.2mm	13.6mm

#### TECTITE SYSTEM PEX EXPANSION

Upper working temperature	Lower working temperature						
	0°C	10°C	20°C	40°C	60°C	80°C	
80°C		15.0mm	13.8mm	12.5mm	9.0mm	4.8mm	0.0mm
60°C		10.2mm	9.0mm	7.7mm	4.2mm	0.0mm	
40°C		6.0mm	4.8mm	3.5mm	0.0mm		
20°C		2.5mm	1.3mm	0.0mm			
10°C		1.2mm	0.0mm				
0°C		0.0mm					

#### STAINLESS STEEL SYSTEM TUBE EXPANSION

Temperature change	Tube length							
	3m	4m	5m	6m	7m	8m	9m	10m
10°C	0.5mm	0.6mm	0.8mm	1.0mm	1.1mm	1.3mm	1.4mm	1.6mm
20°C	1.0mm	1.3mm	1.6mm	1.9mm	2.2mm	2.6mm	2.9mm	3.2mm
40°C	1.9mm	2.6mm	3.2mm	3.8mm	4.5mm	5.1mm	5.8mm	6.4mm
60°C	2.9mm	3.8mm	4.8mm	5.8mm	6.7mm	7.7mm	8.6mm	9.6mm
80°C	3.8mm	5.1mm	6.4mm	7.7mm	9.0mm	10.2mm	11.5mm	12.8mm

#### CARBON STEEL SYSTEM TUBE EXPANSION

Temperature change	Tube length							
	3m	4m	5m	6m	7m	8m	9m	10m
10°C	0.4mm	0.5mm	0.6mm	0.7mm	0.8mm	1.0mm	1.1mm	1.2mm
20°C	0.7mm	1.0mm	1.2mm	1.4mm	1.7mm	1.9mm	2.2mm	2.4mm
40°C	1.4mm	1.9mm	2.4mm	2.9mm	3.4mm	3.8mm	4.3mm	4.8mm
60°C	2.2mm	2.9mm	3.6mm	4.3mm	5.0mm	5.8mm	6.5mm	7.2mm
80°C	2.9mm	3.8mm	4.8mm	5.8mm	6.7mm	7.7mm	8.6mm	9.6mm

# Ballorex Venturi sizing software

This class leading, free to use software is a powerful tool in selecting, providing signal data for Ballorex Venturi valves and, cross checking pipe sizes all in one simple intuitive program. Features include:

*System and branch set up to easily distinguish between two or multiple circuit duties and set operating conditions. Resolve signal data with respect to temperature and inhibitor concentrations as they effect specific gravity.*

*Input an individual flow rate or multiple flows rate data from a spreadsheet.*

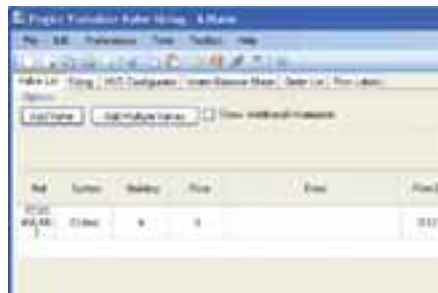

*Pictorial confirmation of the valve selected as confirmation of the type of valve required.*



*Apply a sizing to all valves that possess the same flow rate within a system.*

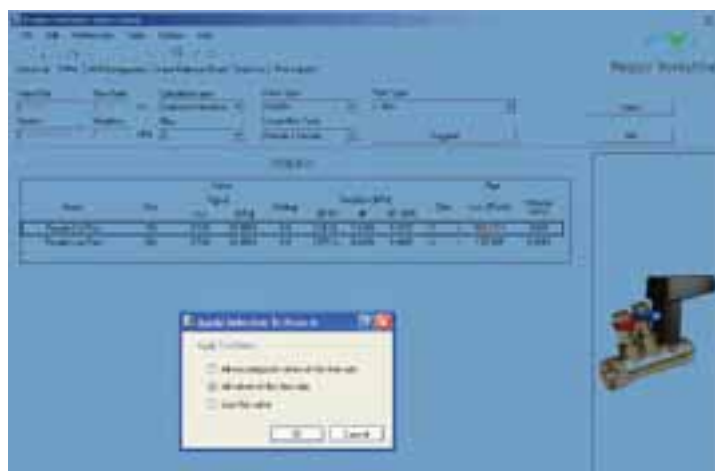

*Configure Modular Valve Systems (MVS) to individual or multiple valve sizing's on the fly using either manual or wizard based tools.*

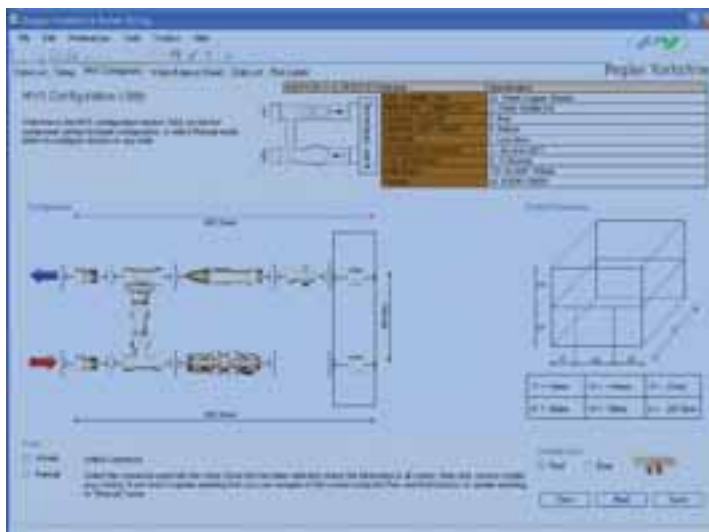

*Correct signal data both for temperature and additive effects on water and produce water balance sheets for the commissioning engineer. The program also permit easy recalculation of signal data with respect to the actual temperature at the time of commissioning.*



*A comprehensive pipe database to easily cross check pipe sizes of the most popular types in mechanical services.*

*Bundled with a tool box of CAD files and catalogues all automatically updated (requires internet connection) to ensure the most up to date information.*





Calculation of flow rate:

$$Q = \frac{Kvs \times \sqrt{\Delta P}}{36}$$

Where

Q = Flow rate (l/s)

ΔP = Signal (kPa)

Kvs = Signal coefficient

FODRV DN 15L - Low flow

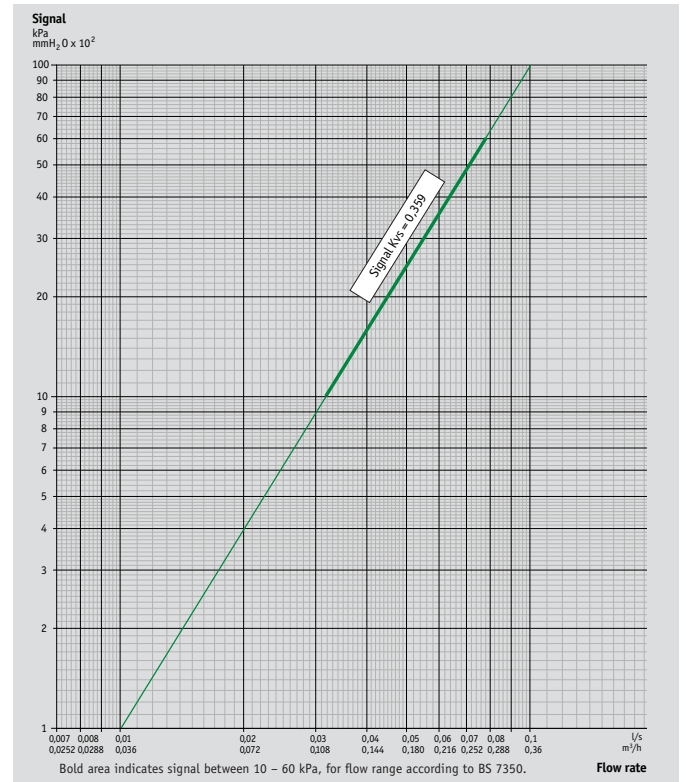

FODRV DN 15S - Standard flow

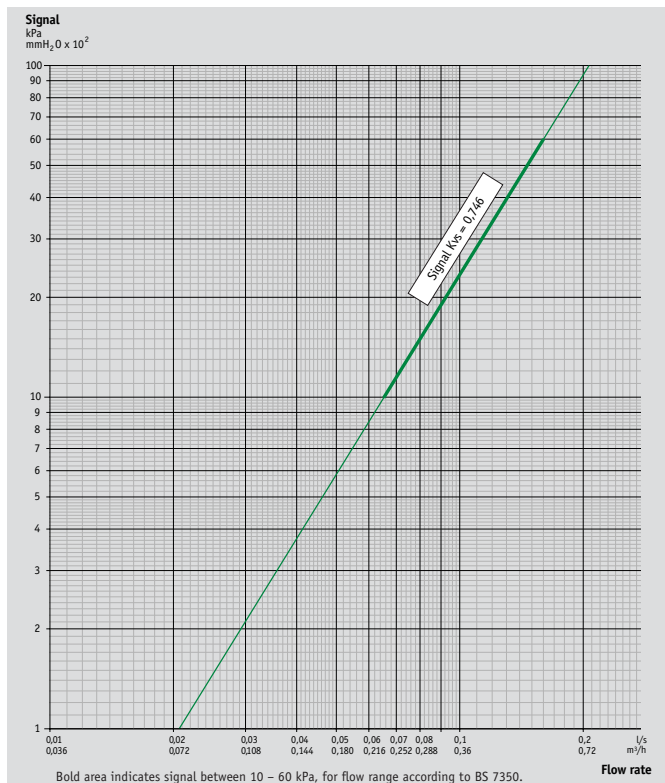

FODRV DN 15H - High flow

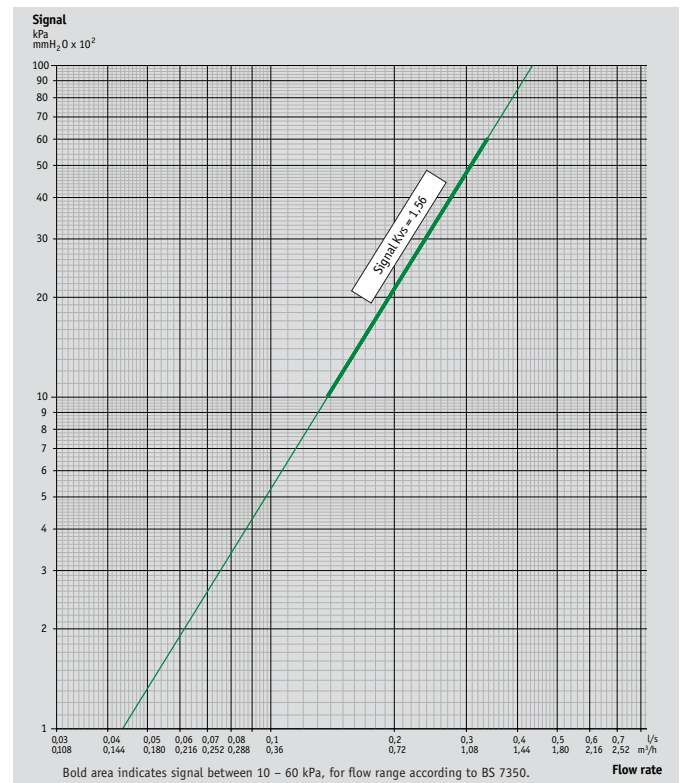

### FODRV DN 20L - Low flow

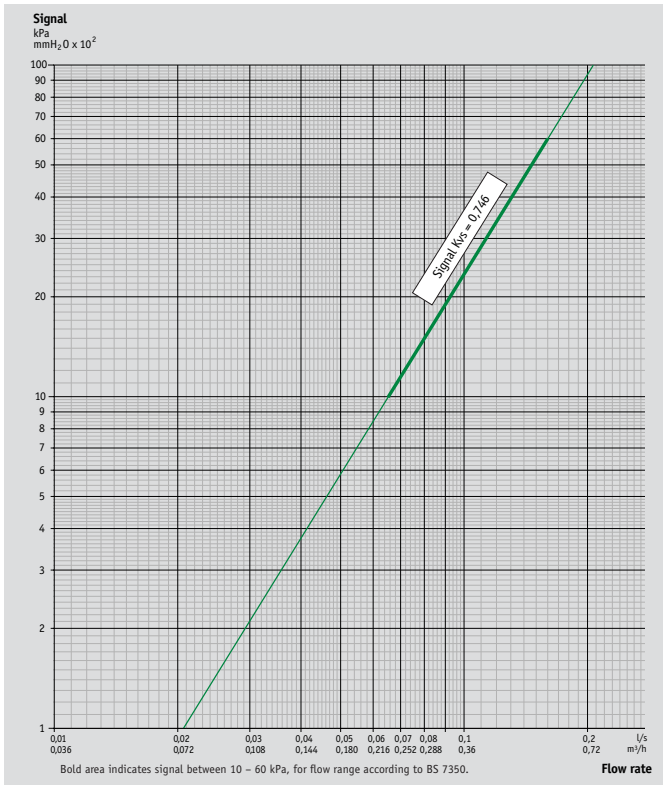

### FODRV DN 20S - Standard flow

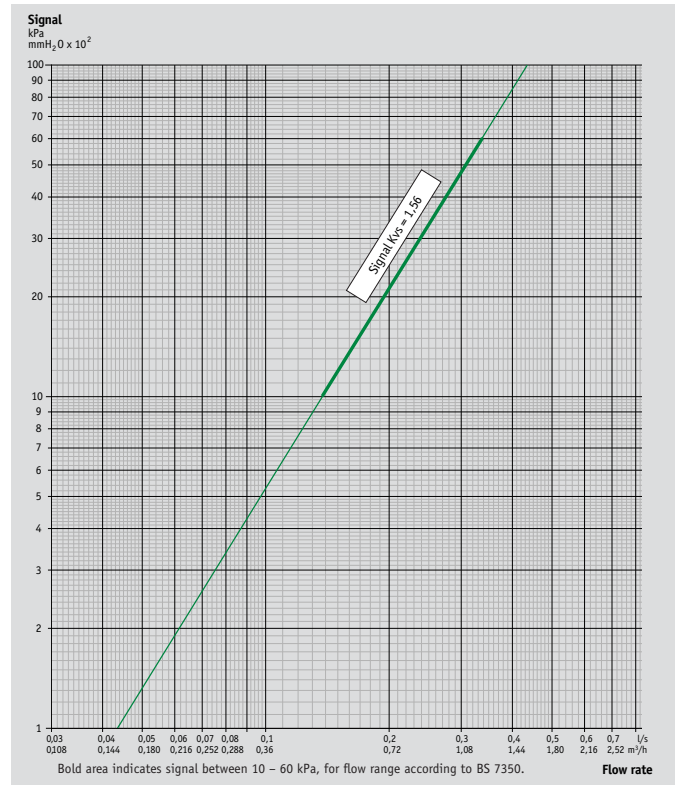

### FODRV DN 20H - High flow

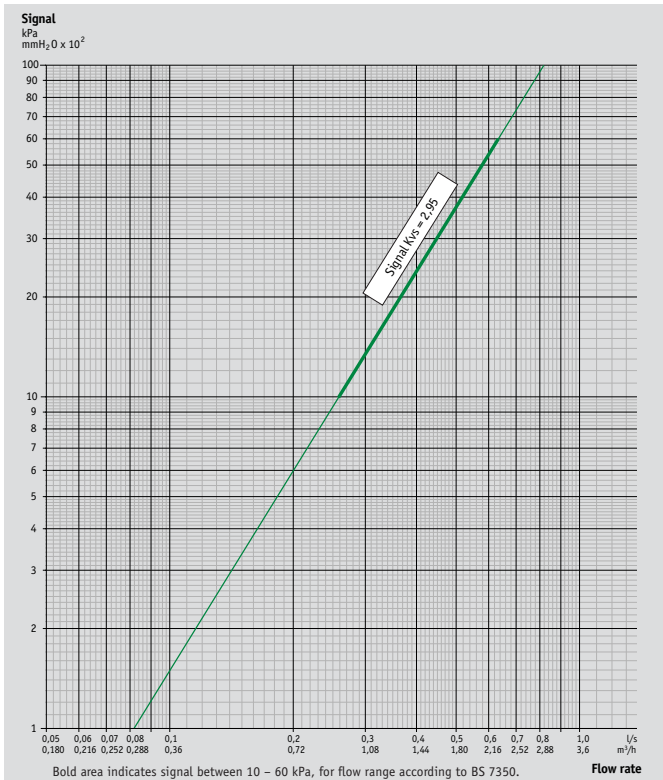

### FODRV DN 25S - Standard flow

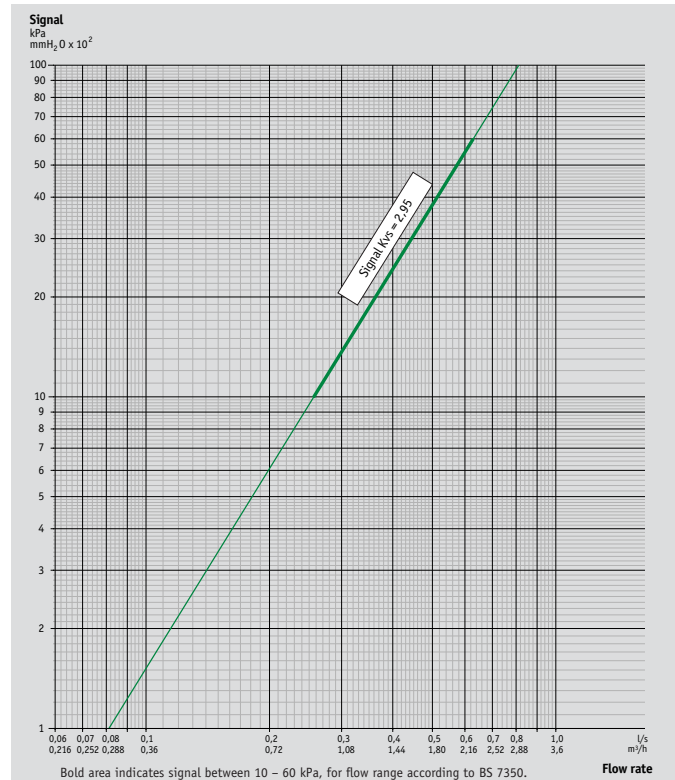

### FODRV DN 25H - High flow

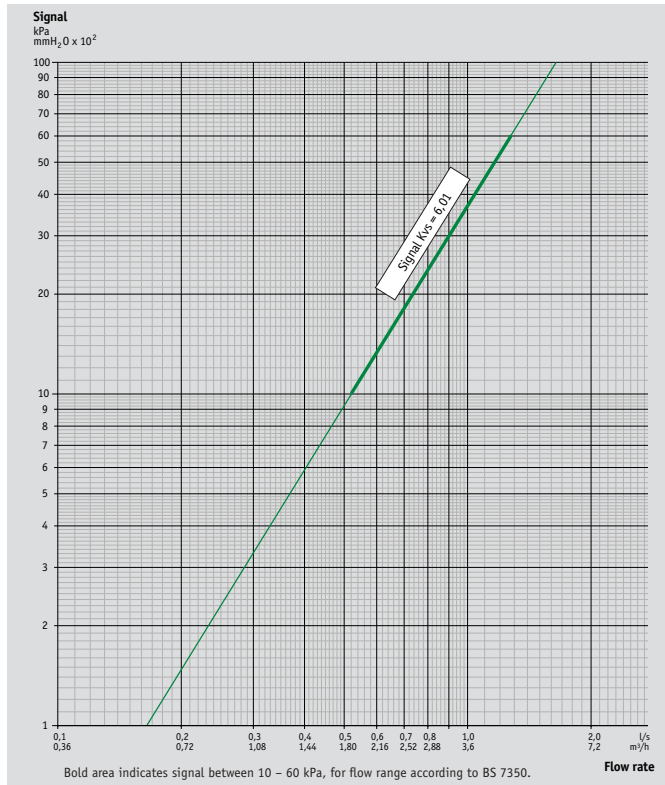

### FODRV DN 32H - High flow

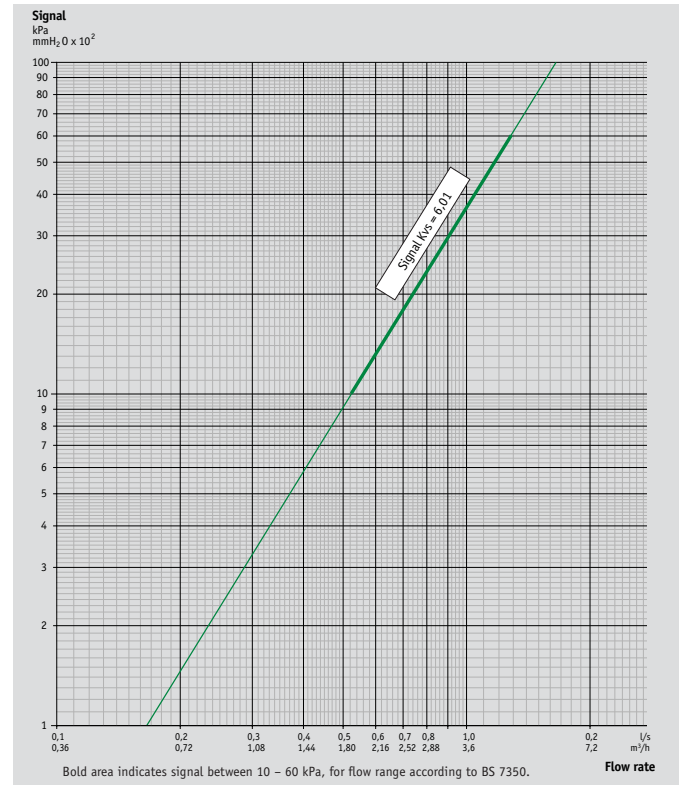

### FODRV DN 40H - High flow

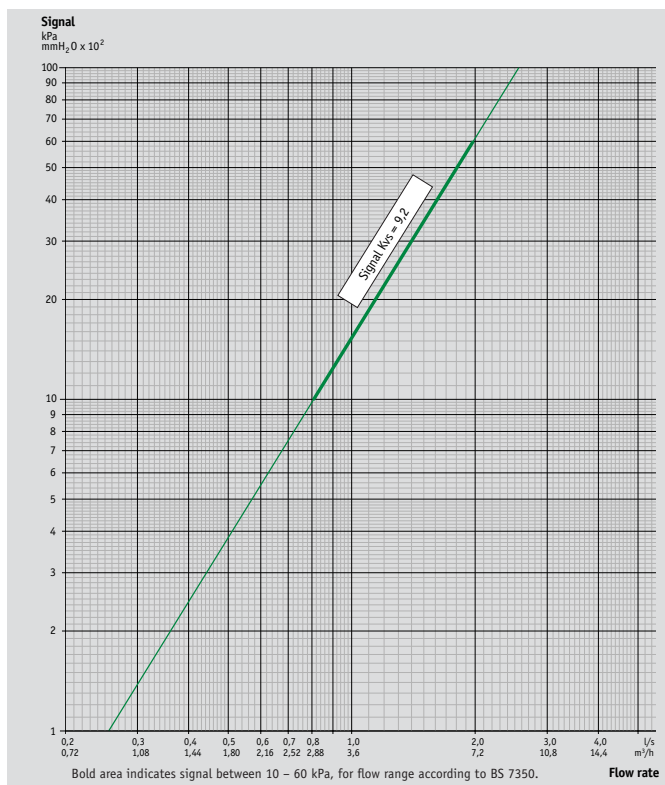

### FODRV DN 50H - High flow

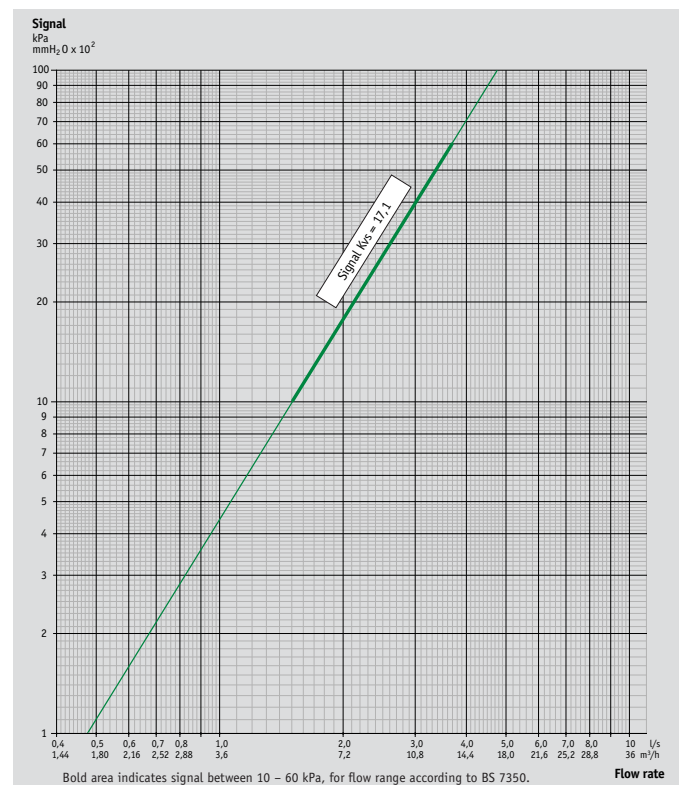

### FODRV DN 65 - Standard and Extended

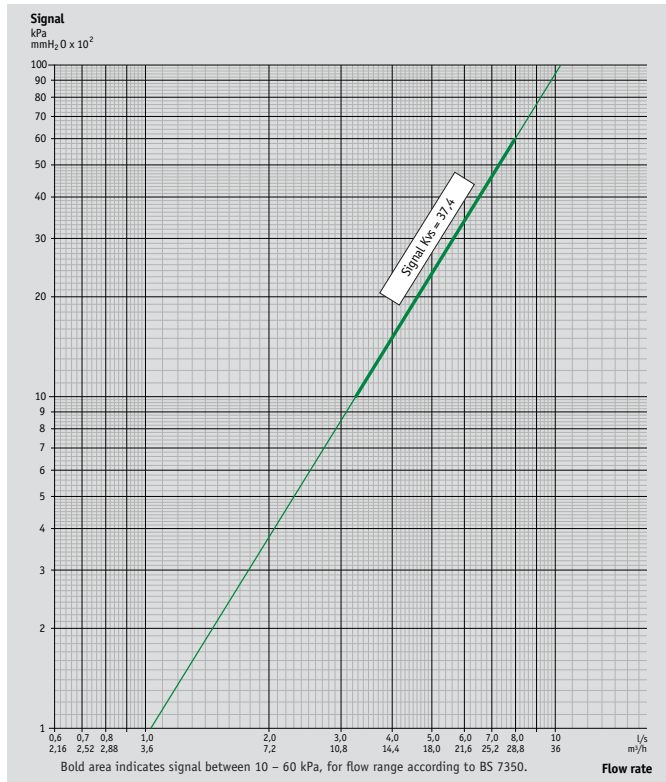

### FODRV DN 80 - Standard and Extended

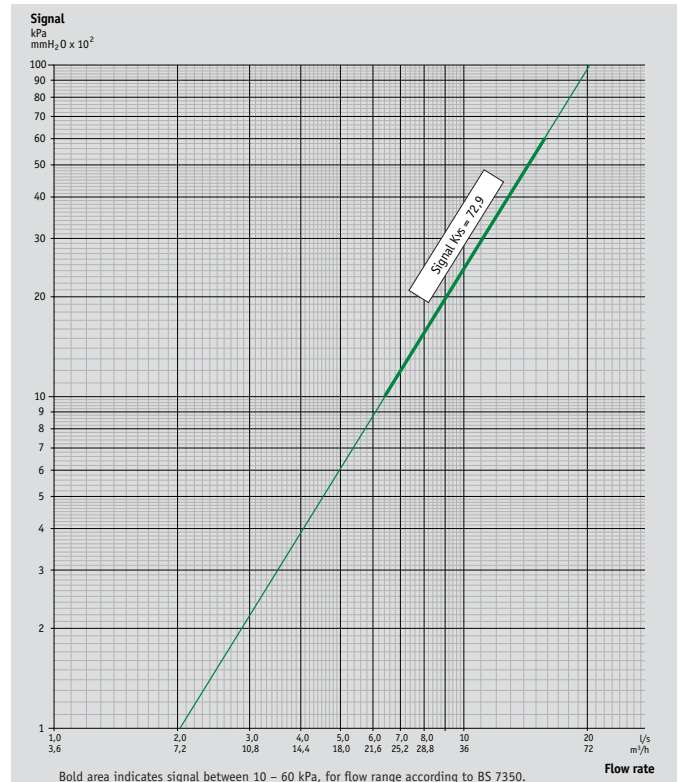

### FODRV DN 100 - Standard and Extended

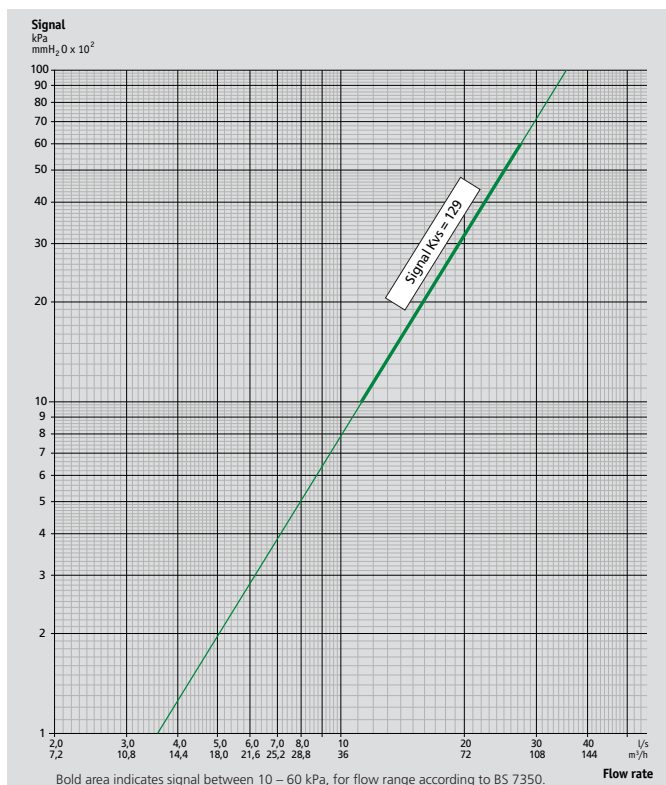

### FODRV DN 125 - Standard and Extended

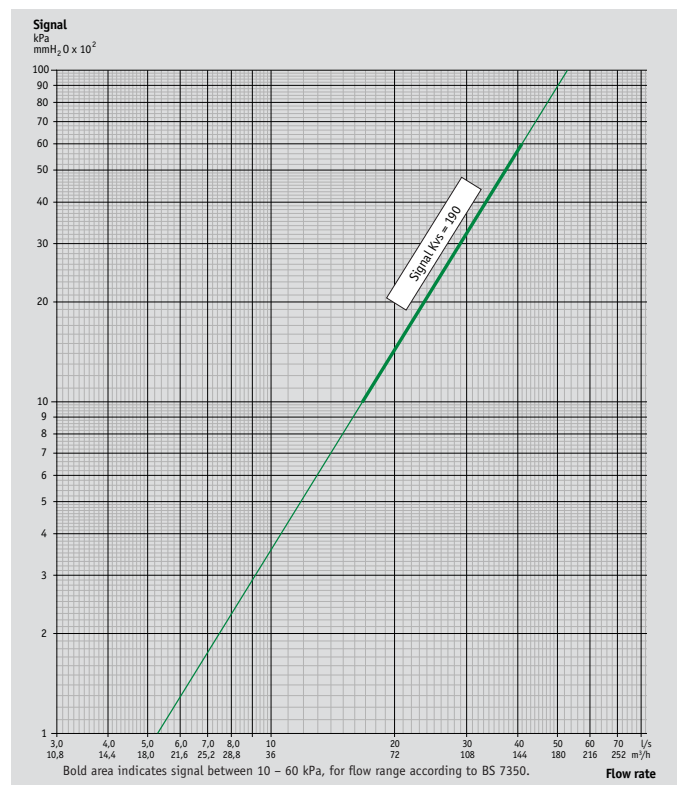

### FODRV DN 150 - Standard and Extended

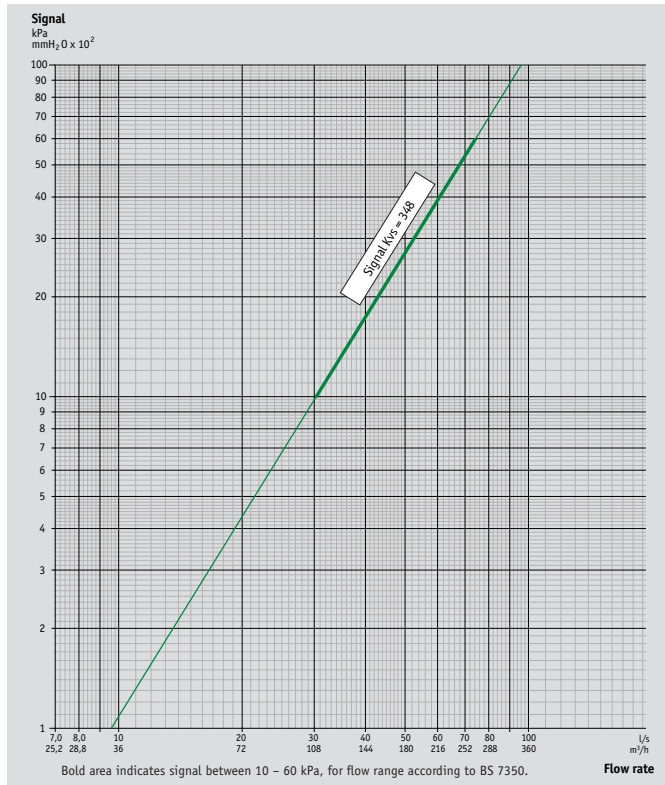

### FODRV DN 200 - Standard

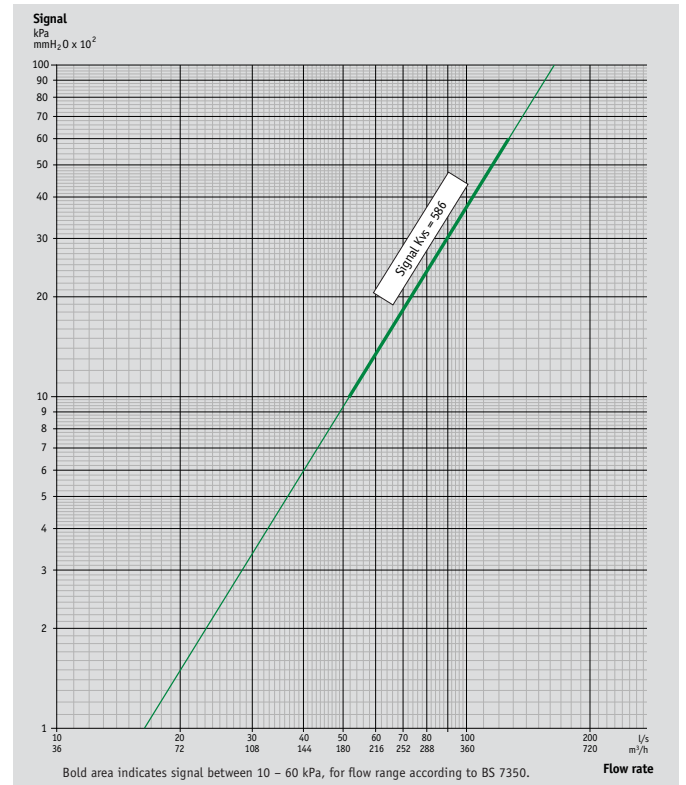

### FODRV DN 250 - Standard

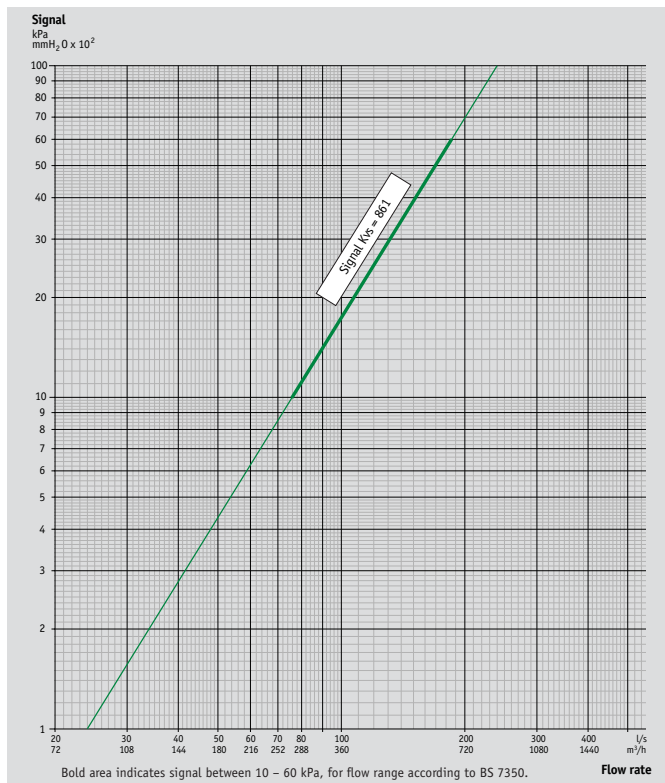

### FODRV DN 300 - Standard

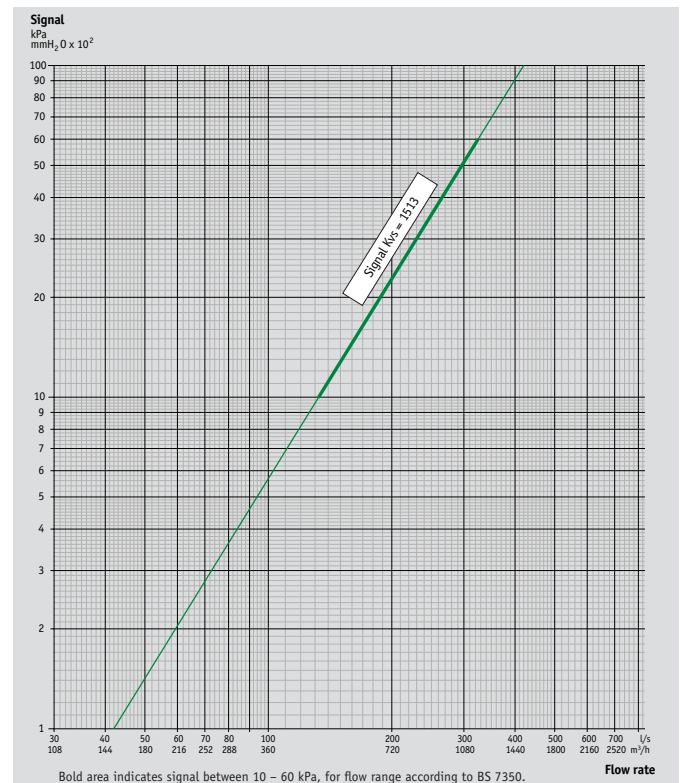

### DRV DN 15L - Low flow

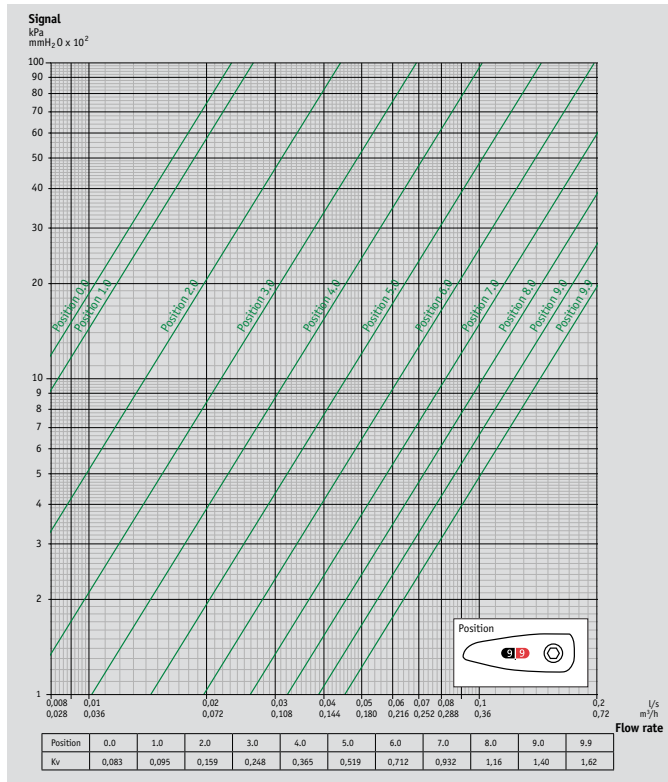

### DRV DN 15S - Standard flow

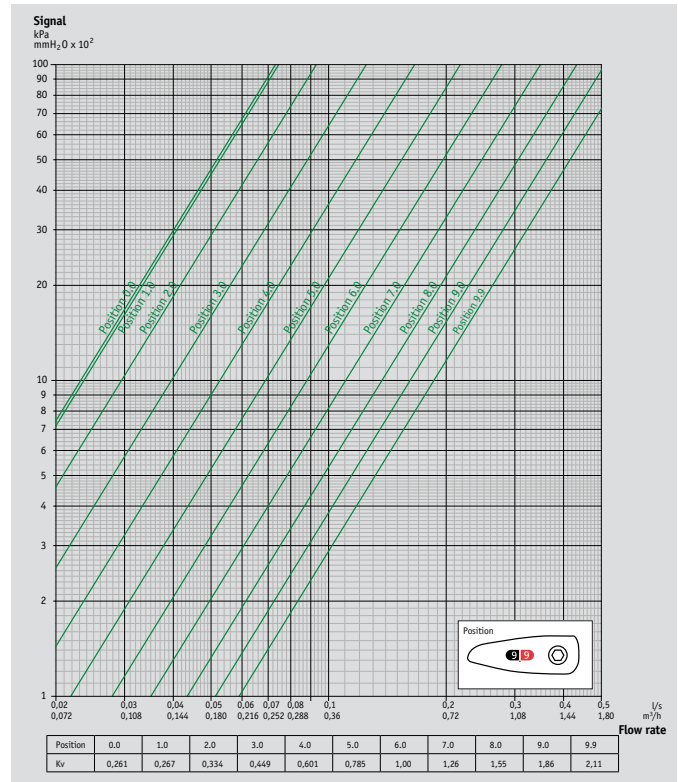

### DRV DN 20L - Low flow

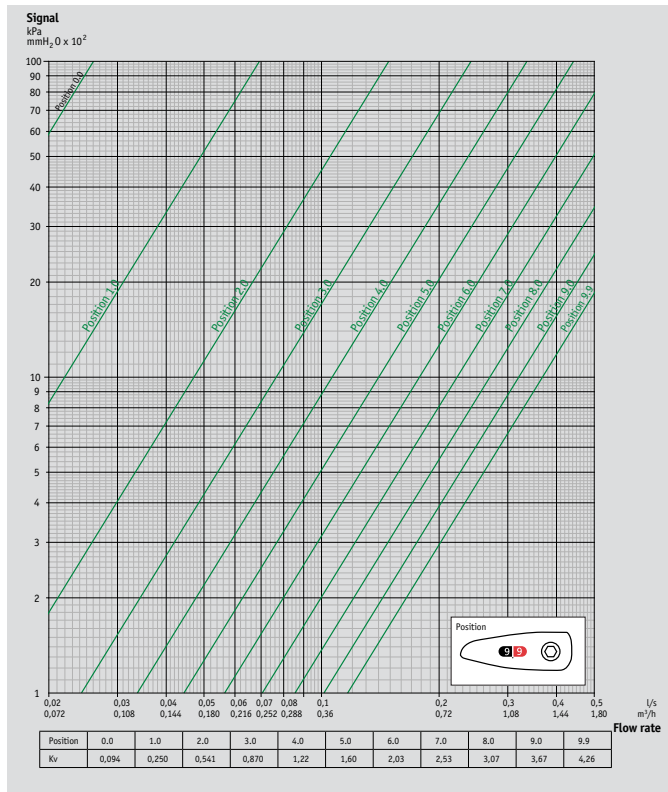

### DRV DN 20S - Standard flow

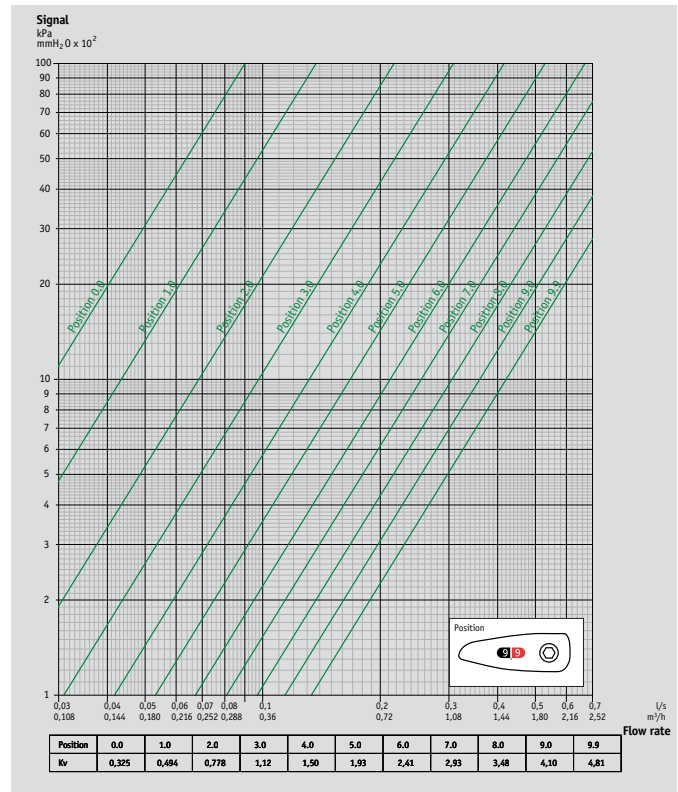

### DRV DN 25S - Standard flow

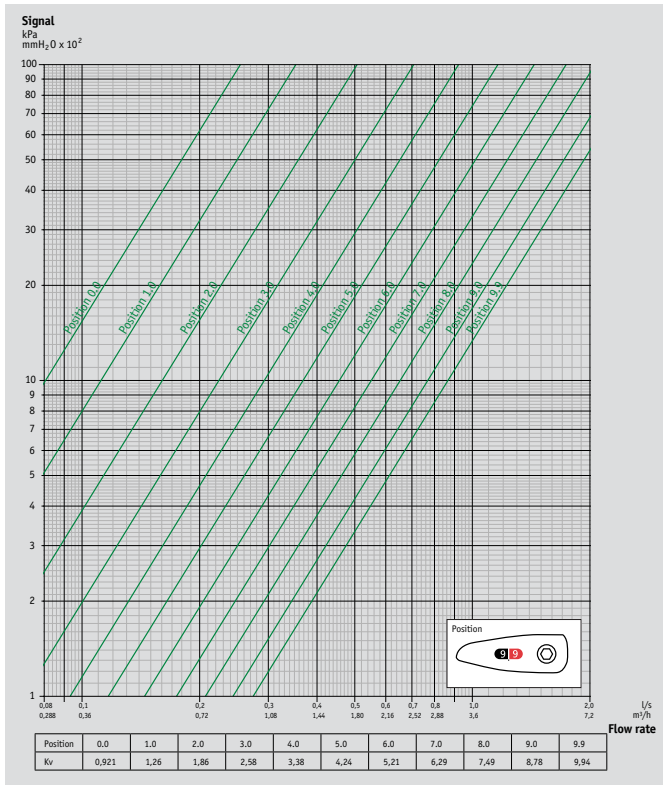

### DRV DN 32S - Standard flow

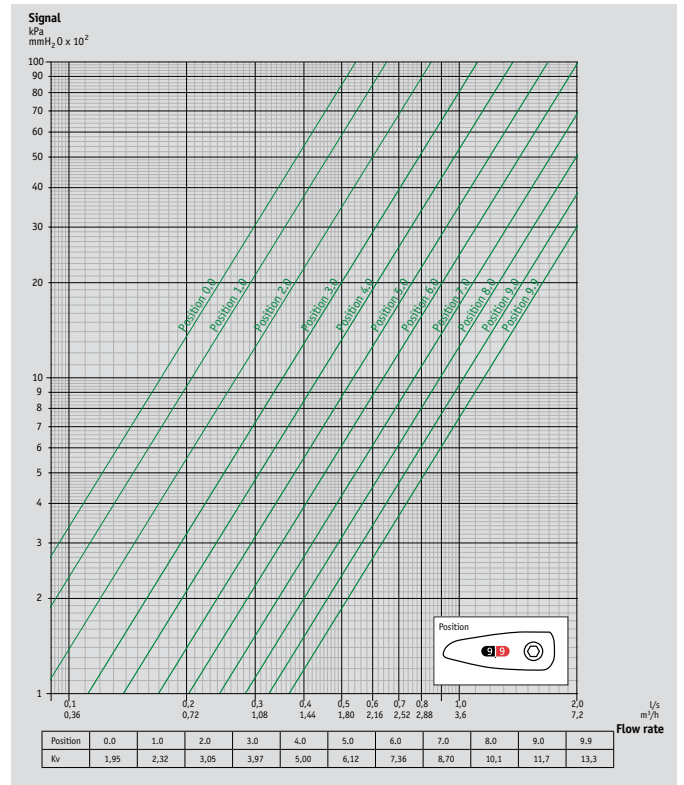

### DRV DN 40S - Standard flow

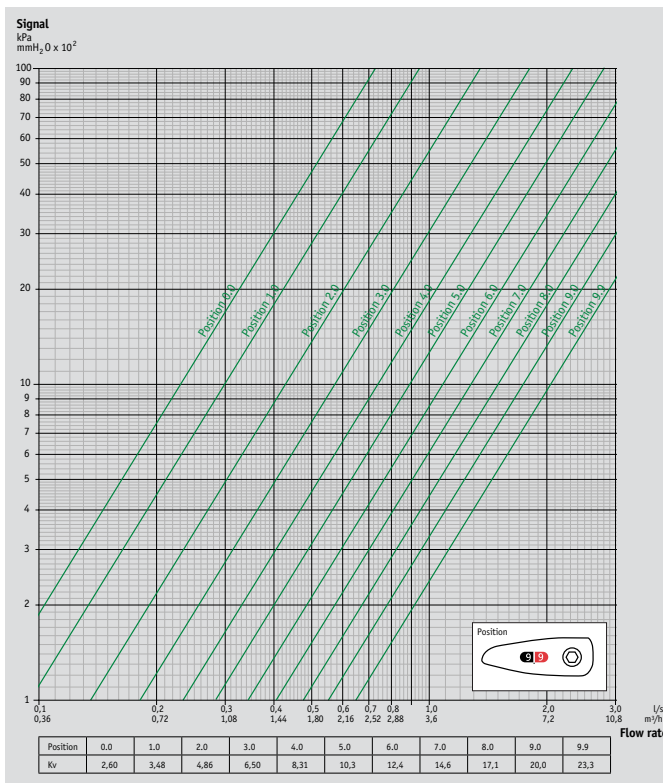

### DRV DN 50S - Standard flow

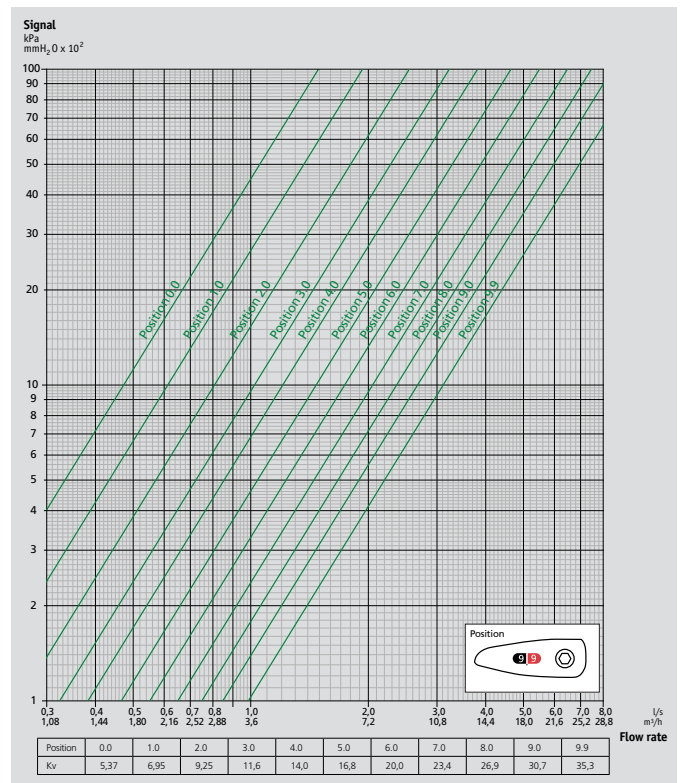

# PEGLER

## Flow Charts

### DRV DN 65

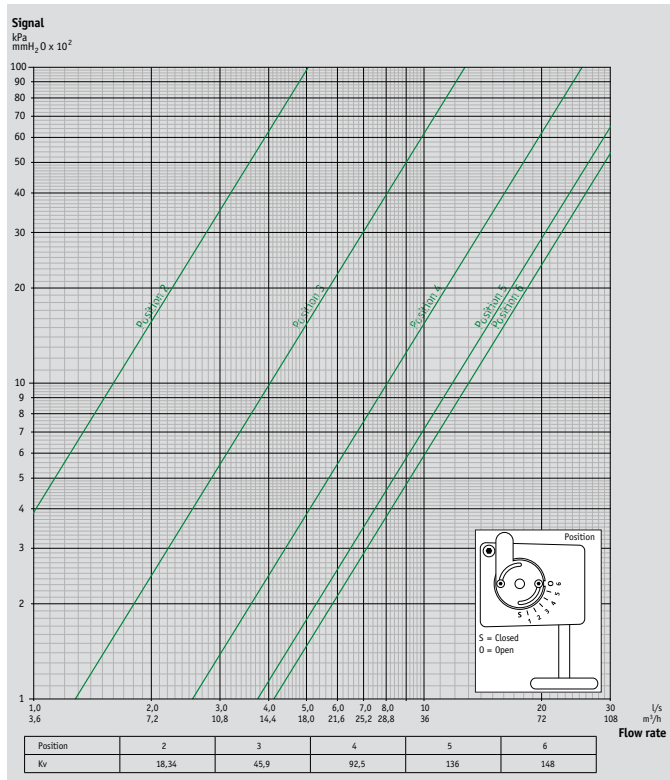

### DRV DN 80

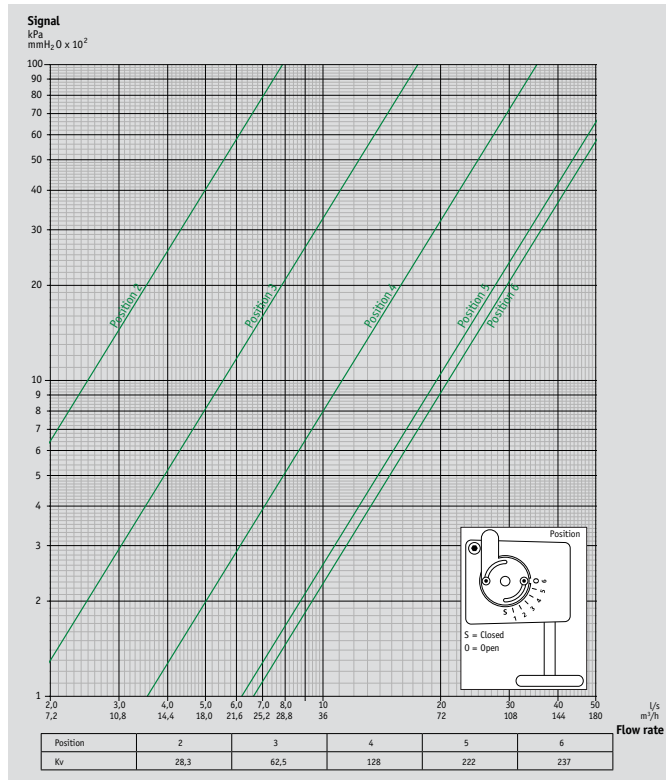

### DRV DN 100

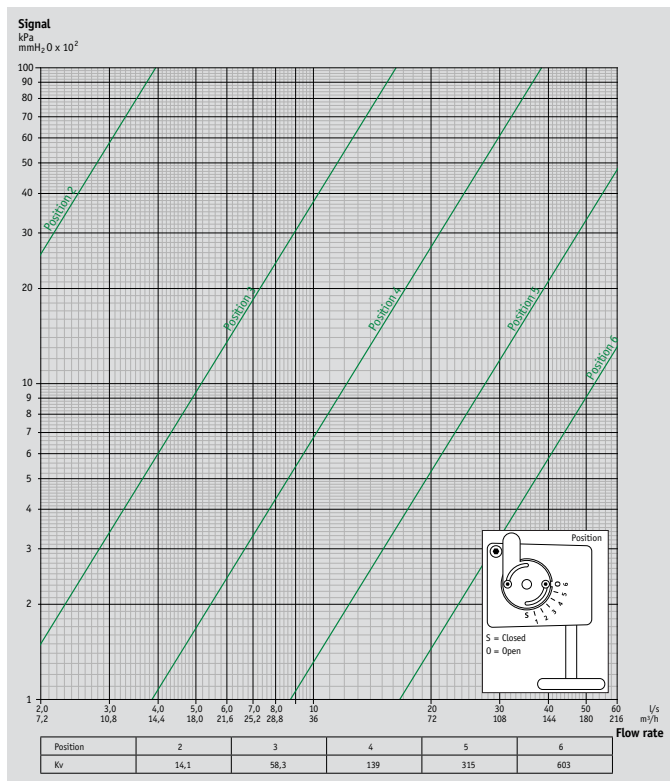

### DRV DN 125

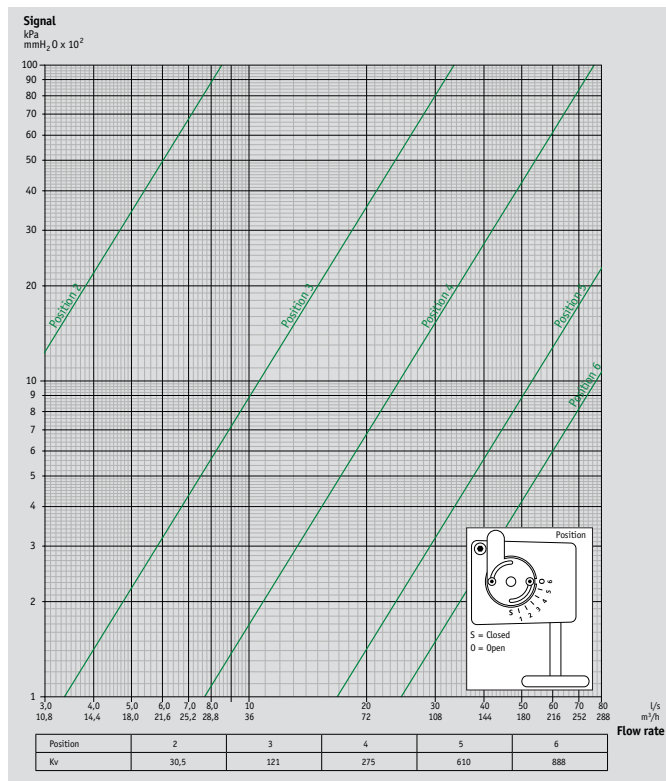



### DRV DN 150

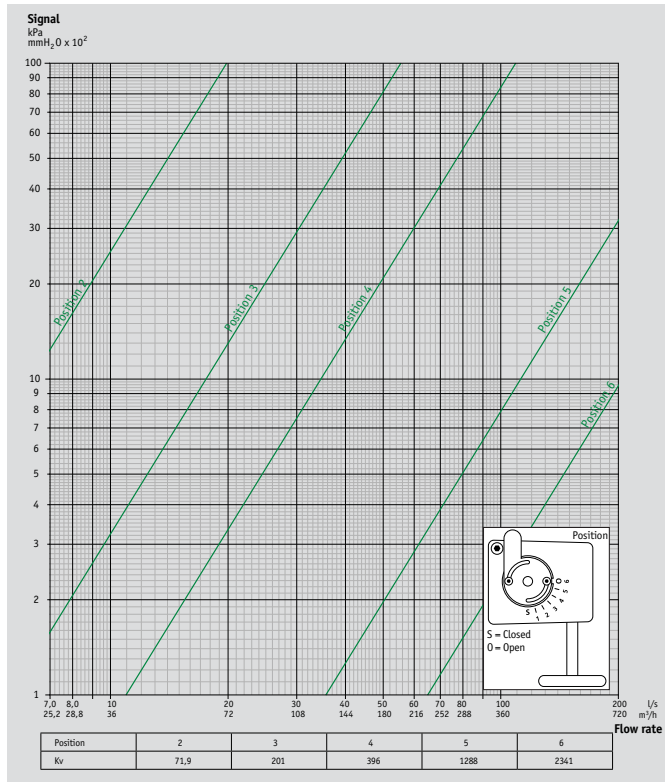

### DRV DN 200

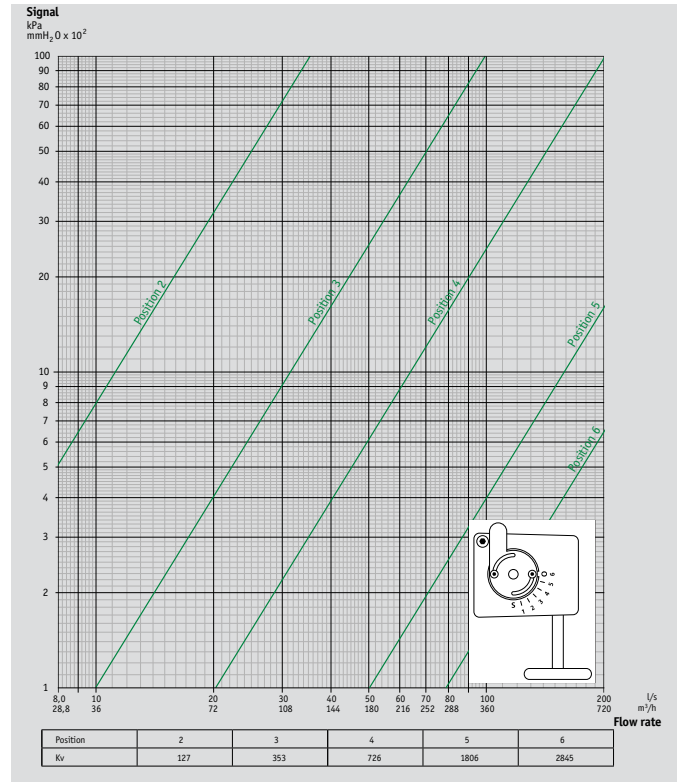

### DRV DN 250

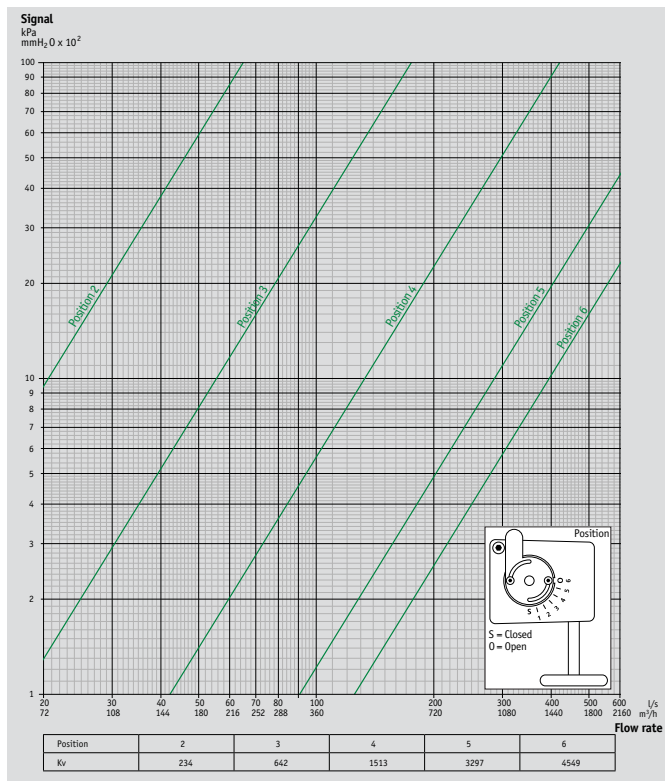

### DRV DN 300

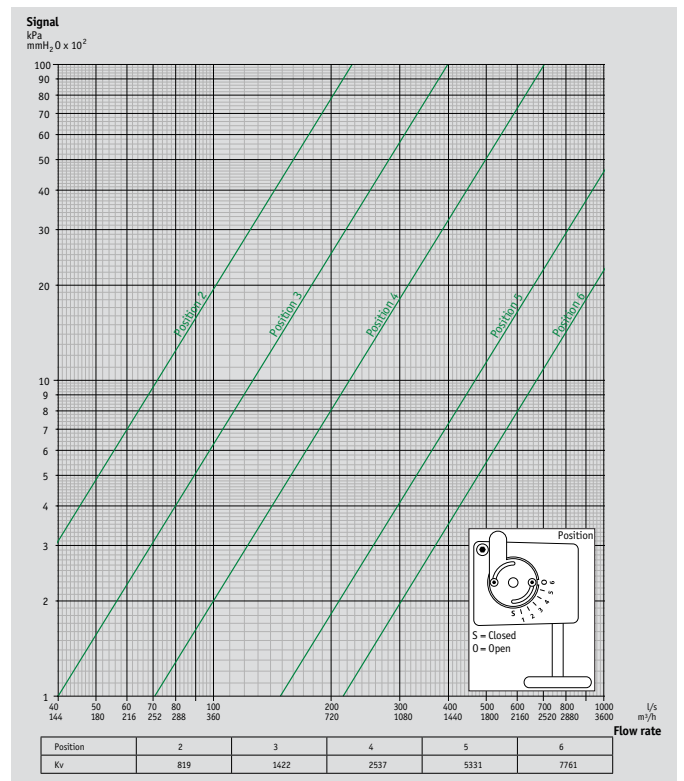







# Pegler Yorkshire

*Our brands:*



## *UK sales*

Free Phone: 0800 156 0010  
Free Fax: 0808 156 1011  
Email: [uk.sales@peglyorkshire.co.uk](mailto:uk.sales@peglyorkshire.co.uk)

## *Export*

Tel: +44 (0) 1302 855 656  
Fax: +44 (0) 1302 730 513  
Email: [export@peglyorkshire.co.uk](mailto:export@peglyorkshire.co.uk)

## *Technical Help*

Free Phone: 0800 156 0050  
Free Fax: 0808 156 1012  
Email: [tech.help@peglyorkshire.co.uk](mailto:tech.help@peglyorkshire.co.uk)

## *Brochure Hotline*

Free Phone: 0800 156 0020  
Free Fax: 0808 156 1011  
Email: [info@peglyorkshire.co.uk](mailto:info@peglyorkshire.co.uk)

[www.peglyorkshire.co.uk](http://www.peglyorkshire.co.uk)

## **Pegler Yorkshire Group Limited**

St. Catherine's Avenue, Doncaster,  
South Yorkshire, DN4 8DF, England.  
Tel: 0844 243 4400 Fax: 0844 243 9870

Registered in England Company No. 00401507  
Registered Office: Haigh Park Road, Stourton, Leeds,  
West Yorkshire, LS10 1RT, England.

All brand names and logo styles are registered trademarks.  
Maintaining a policy of continual product development,  
Pegler Yorkshire reserves the right to change specifications, design  
and materials of products listed in this publication without prior notice.

LIT.REF: 880139.05.09

