



Solar pump stations



Pegler Yorkshire

Unrivalled quality, innovation, customer service and long-term value for money

As part of the global Aalberts Industries NV Group, Pegler Yorkshire is one of Britain's largest and most respected manufacturers of innovative products for the demanding and diverse plumbing and heating industries.

Pegler Yorkshire – a unique story

It was in the late 19th century when two separate and altruistic companies set out on the long road to satisfying the needs of prospective customers and, of course, to profit in the process. Coincidentally located just 30 miles apart, each was driven by the same vision and ideals of a no-compromise culture. Cutting corners was never an option and only the best could ever be good enough.

These two companies were Pegler and Yorkshire Fittings. In meeting all the challenges of the 20th and 21st centuries both companies have changed a great deal, the business ethos common to both never has. And now these two like minds have come together as Pegler Yorkshire – a single source of proven, flow control solutions for installers, specifiers and engineers in the domestic, public and commercial markets.

Reputable and established brands

Just as Pegler and Yorkshire have endured over such a long period, many of the brand names they have created over time are similarly very well established, in many cases as market leaders in their respective categories. The very extensive Pegler Yorkshire product range now comprises more than 15,000 lines – without rival for the choice and coverage it offers and for the number and scope of applications it satisfies.

A mind for innovation

Brands which endure and are not easily displaced must by definition be the product of innovative thinking and technology that continually stand the test of time. Pegler Yorkshire's no-compromise philosophy will always put new product development high on the agenda, based on not only meeting the needs of today's markets, but also anticipating and meeting customers' future needs.

The true value of knowledge

As well as the benefit of unparalleled experience of the flow control market and its growth over many decades, Pegler Yorkshire has strong associations with major industry bodies such as those responsible for determining product and performance standards.

The result is a comprehensive store of knowledge and reference which is invaluable in the key areas of research, development and dealing efficiently and accurately with customer enquiries – particularly with regard to product application and suitability.

A charter for the best in customer service

With such a diverse product range and customer base, Pegler Yorkshire's no-compromise standards of quality, reliability and value for money naturally go hand in hand with the principle of delivering the best in customer service.

Green awareness and responsibilities

Developing products which reduce the carbon footprint by saving water and energy is only one side of the green issues coin. Pegler Yorkshire is also increasingly committed to recycling key production materials (such as brass), eliminating the need for excessive packaging wherever possible, and looking for new ways in which the company's day-to-day operations can be improved to reduce waste and minimise the impact on the environment.

Likewise, social responsibilities such as supporting employee and local community welfare are aspects of the very fabric and philosophy upon which both Pegler and Yorkshire were founded.

Standards

Pegler Yorkshire is dedicated to designing, developing and manufacturing products of the highest quality. We are members of numerous standards committees and take an active part in their development. Our products, where applicable, comply with the relevant British, European and International standards. Whatever the latest developments, we guarantee that our products will always meet the latest and highest standards.



Trade bodies

Pegler Yorkshire is pleased to be associated with several influential industry organisations:



Association of Plumbing and Heating Contractors



The Bathroom Manufacturers Association



Construction Products Association

Brass

The Brass Page for specifiers, designers, engineers and manufacturers



British Plumbing Employers Council



Builders Merchants Federation



The Copper Development Association



The UK Copper Board



Institute of Plumbing



Heating and Ventilating Contractors Association



Thermostatic Mixing Valve Manufacturers Association

Thermostatic Mixing Valve Manufacturers Association



Scottish and Northern Ireland Plumbing Employers Federation

 This data book has been produced in clearly defined sections to help the user to find relevant information quickly and easily. At the foot of each page there is a reminder of the brochure sections with the relevant page numbers.

Section 1

Product range overview

Introduction to Meibes	4-5
Key features and benefits	6
Choosing your system	7
Types of system and adaptations	8-9
Product overview	10-13

Section 2

Product range details

Sizes, dimensional details and product codes	14-19
--	-------

Section 3

Technical Data

Solar pump stations	20-21
Solar control panels	22-23
Flow charts and performance	24

Section 4

The Meibes range

Solar commercial range	25
------------------------	----

Section 5

Solar XPress

Press-fit solutions	26
---------------------	----



Energy-saving solutions for new and existing domestic hot water systems

Throughout Europe the Meibes brand is recognised as a solutions provider of Pump Groups for renewable products in both domestic and commercial applications. Whether a solution is required for individual properties, multi-level buildings, Meibes from Pegler Yorkshire can provide the answer.

In the United Kingdom the move towards renewable technologies continues to gather pace, fuelled partly by government targets and legislation like the Building Regulations and the Code for Sustainable Homes, and increasing consumer awareness of the need to invest in green technology. Rising prices have also focussed attention on the need to reduce fuel bills by looking at renewable technologies such as solar thermal hot water.

At Pegler Yorkshire we are committed to providing professional installers with the products, technical expertise and knowledge which will enable them to meet

their customer's requirements and provide new business development opportunities using the technologies of the future.

Why choose Meibes?

The pump station is the heart of the solar thermal system and when you specify Meibes you can rest assured in the knowledge that you've chosen a product that has been proven throughout Europe where solar technology has been widely used for homes and commercial properties of all sizes and descriptions.

The pump station is used for the primary circuit of a solar thermal heating system and controls the temperature of stored hot water. The pump within the unit is activated by a signal from the collector or cylinder to the controller which monitors the differential temperatures.

Meibes pump stations are supplied as prefabricated units that transfer heat from the solar collector to a twin coil cylinder. Each pump station contains all the necessary components i.e. valves, fittings and safety devices etc. that are required to ensure the optimum performance of the solar thermal system. Meibes solar pumps are simple and quick to install,



offer significant savings on installation time and are easy to maintain.

Meibes offers a comprehensive range of pump stations which are designed to offer the installer maximum flexibility and the widest choice for any application. The Meibes range also includes pipe options, connections, fittings, controls and a wide range of accessories. Pump stations are compatible with all types of solar cylinder and solar thermal collectors.

Whether competitive pricing, the system application, or a combination of both is key, Meibes from Pegler Yorkshire can provide the answer.



Meibes pump stations – The heart of the solar thermal system

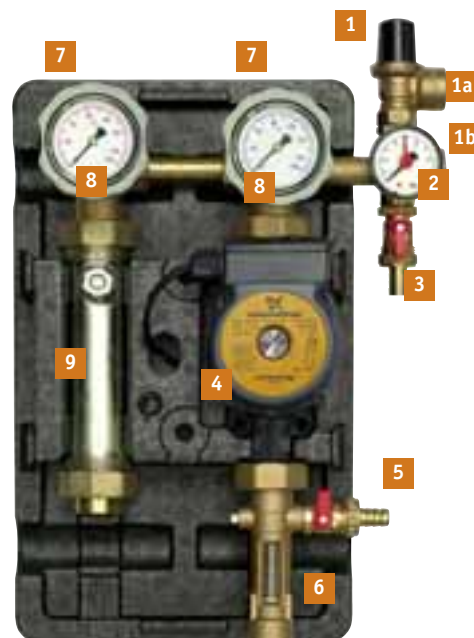
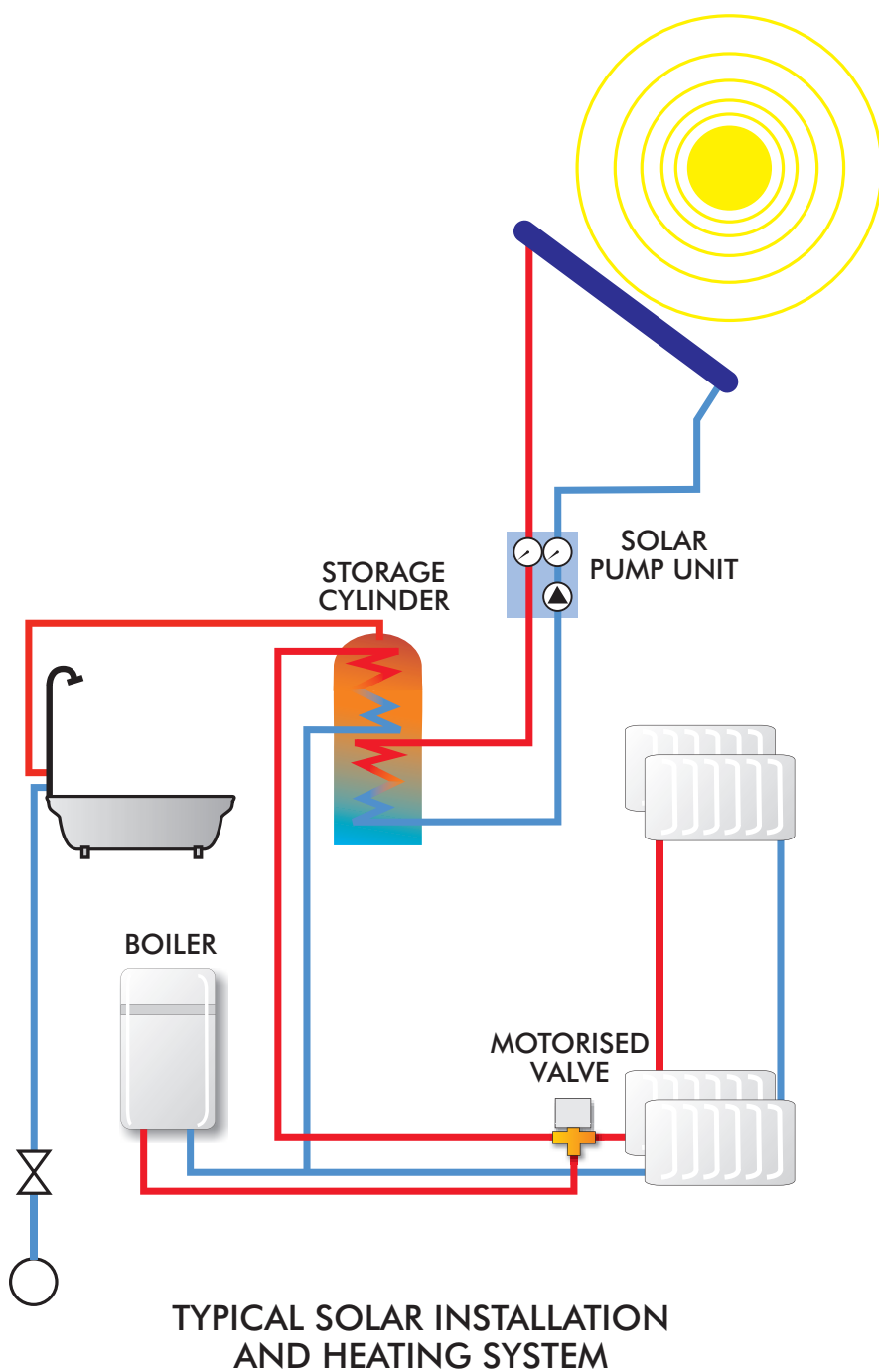

- | | |
|---------------------------------------|---|
| 1 Pressure valve (6bar) | 5 KFE tap with cap (return) |
| 1a Discharge pipe | 6 Volume flow indicator |
| 1b Expansion vessel connection | 7 Ball valve with built-in non-return valves |
| 2 Pressure gauge | 8 Thermometer |
| 3 KFE tap with cap (flow) | 9 Air catcher |
| 4 Solar pump | |

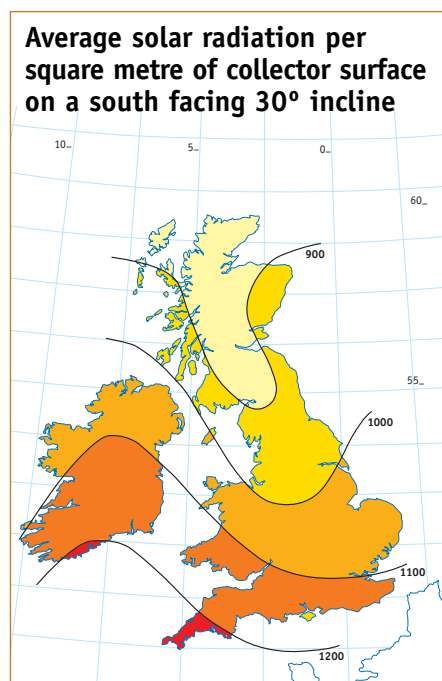

Solar pump stations Introduction, features and benefits

Quick assembly solutions for the professional solar installer

Solar panel

1 Corrugated Pipe

2 Joint and Connection Sets

3 Solar Pump Station

4 Expansion Vessel Mounting Kit

5 Expansion Vessel

6 Powerfill Solar Filling Pump

7 Glycol Fluid

8 Controls

The Meibes solar range offers a comprehensive choice of pump stations and accessories suitable for use on solar thermal hot water systems with either south or east/west facing collectors. All pump stations incorporate the latest valve technology.

- Mobile, compact unit for filling, rinsing and flushing
- Delivery rate 5–50l/min
- Maximum generating pressure 5.5bar
- Exceptionally light weight – only 14kg

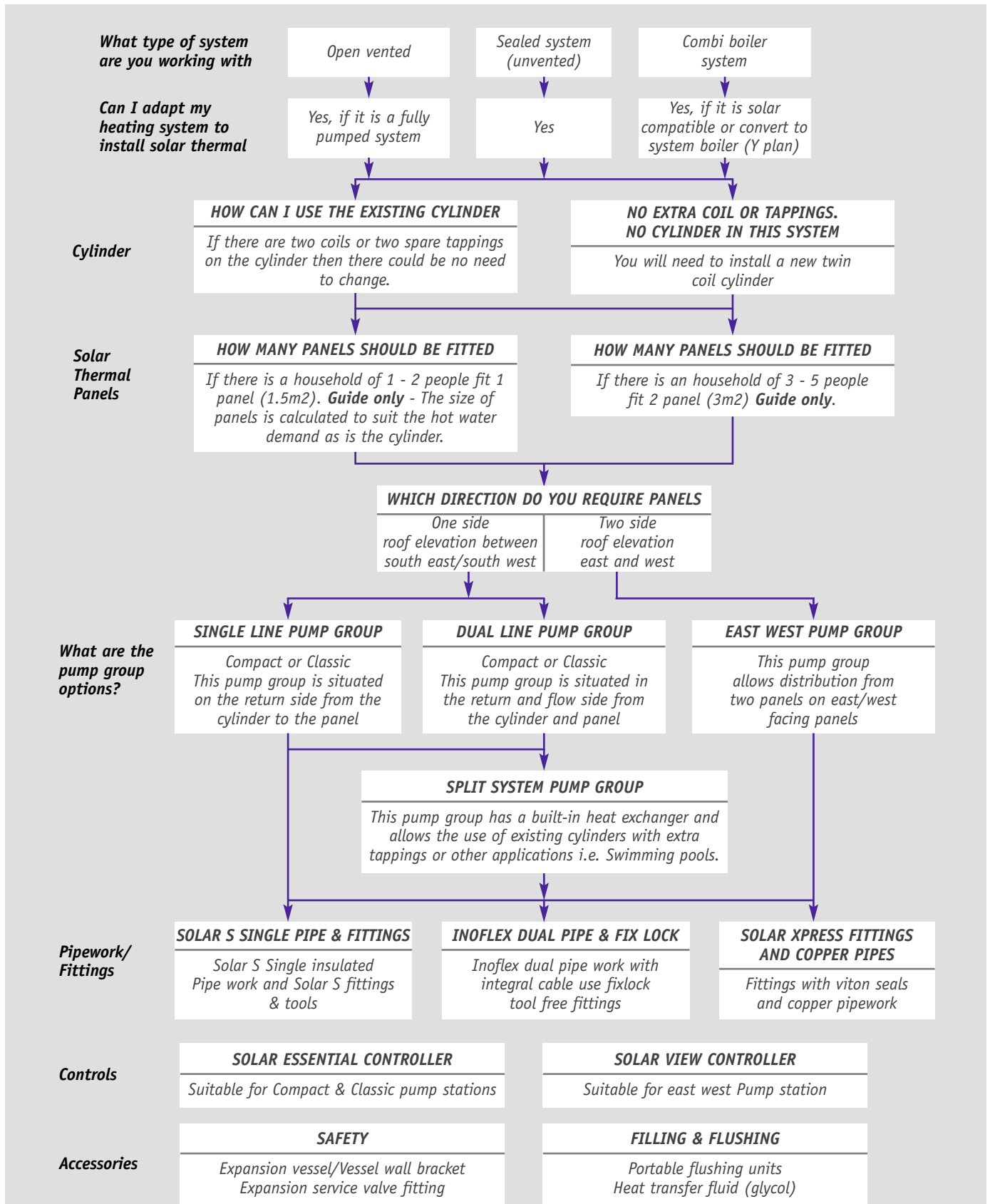

Solar pump stations

Types of system and adaptations

ALL SYSTEM DRAWINGS ARE A REPRESENTATION OF VARIOUS SYSTEMS

Unvented *Shown with dual line*

- With dual solar pump station.
- Pressurised cylinder/twin coil.

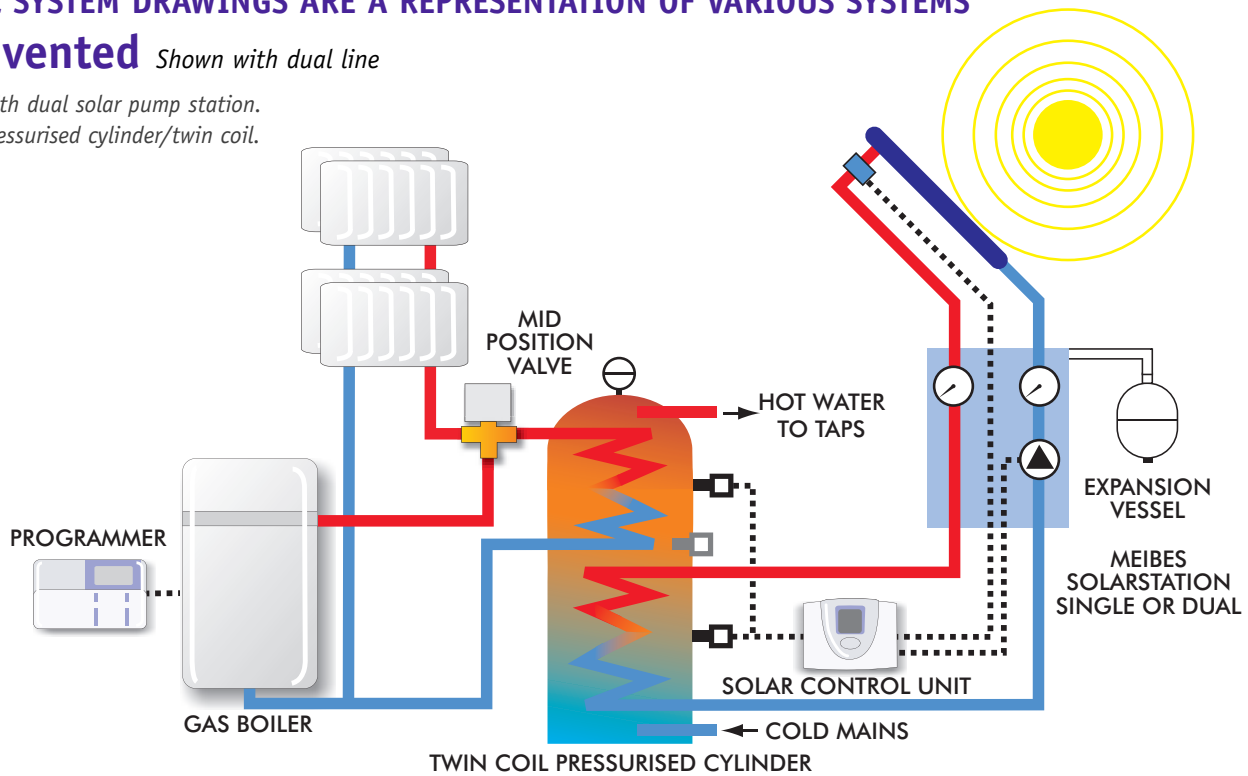

Vented or unvented

- With split solar pump station.

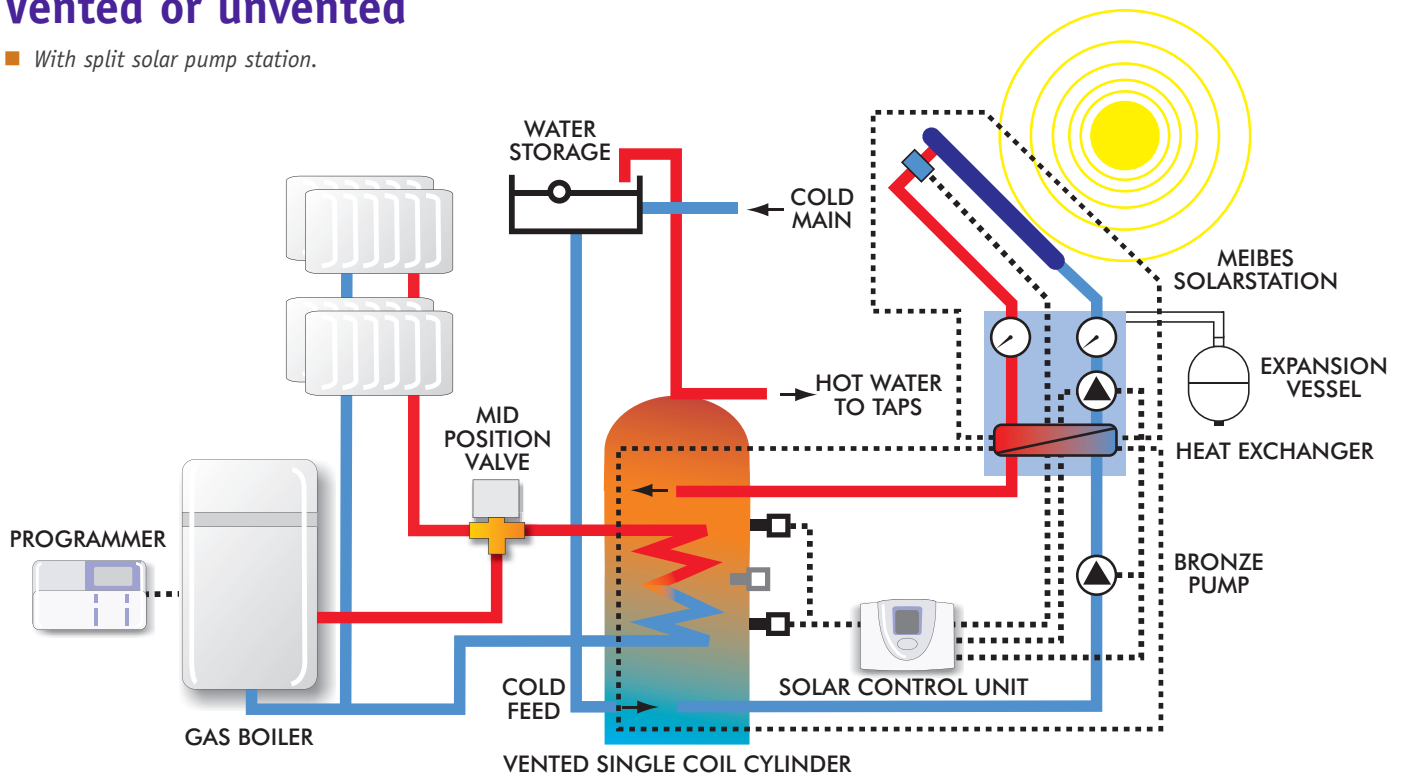

Unvented

- With east/west configuration.
- Pressurised cylinder/twin coil.

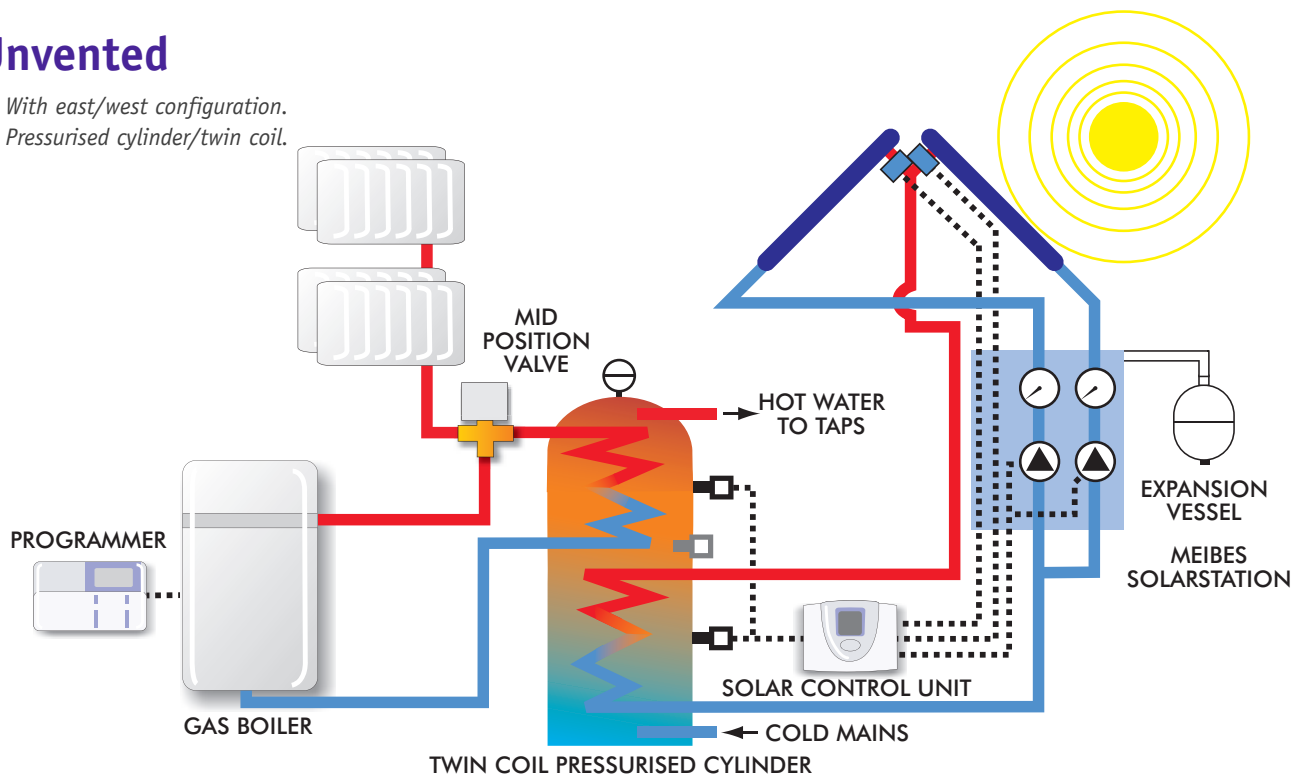

Unvented

- With dual solar pump station.
- Pressurised cylinder/single rail.

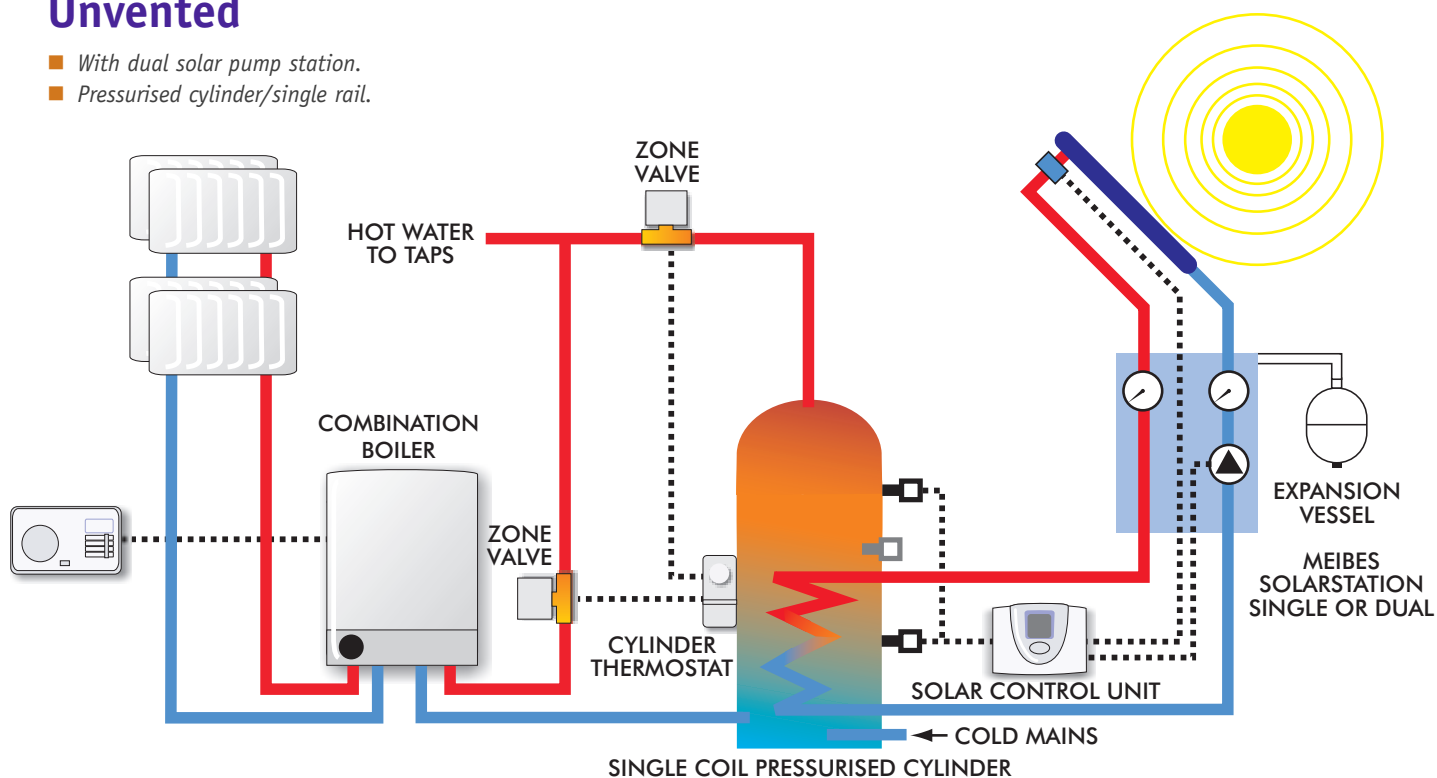

Note: To convert a combi boiler to a system boiler with 'Y' plan control.

Single Solar Station

Installed into the 'return' line from the cylinder/store to the roof collector this 'Single Line Pump Station' is available in either 'Classic' or 'Compact' versions. It is supplied complete with a Grundfos solar circulating pump with a 2 metre connecting cable. (Classic: 'Low Energy' Solar 25 - 65 DN25 EL 180mm, Compact: 'Low Energy' Solar 15 - 65 DN 25 130mm)

Within the solar pump 'return' is a 3-way directional distributor that incorporates a manually adjustable non-return and isolating ball valve together with an over pressure relief valve (6bar). The pump station also features a thermometer head with a display range of 20 - 150°C as well as a system pressure gauge.

A connection point for a solar rated expansion vessel is located within a further distributor, which also includes an isolating ball valve, that is fitted above the

volumetric flowmeter. It is supplied complete with flow and return filling points with dedicated isolating ball valves for system commissioning purposes.

This, easy to install, solar pump station unit is supplied complete with a 2 part EPP insulated cover.

Features

- 'Over pressure' safety relief valve
- Manually adjustable non-return and isolating ball valves
- Flow and return filling points
- Grundfos 'Low Energy' solar rated circulating pump
- 3/4" BSP connections
- Volumetric flowmeter
- Connection point for a solar rated expansion vessel
- System pressure gauge
- 2 part EPP insulated cover
- 'Classic' or 'Compact' versions available
- Ideal for use with solar 'Essential' controller
- Collector area: up to 12sqm.

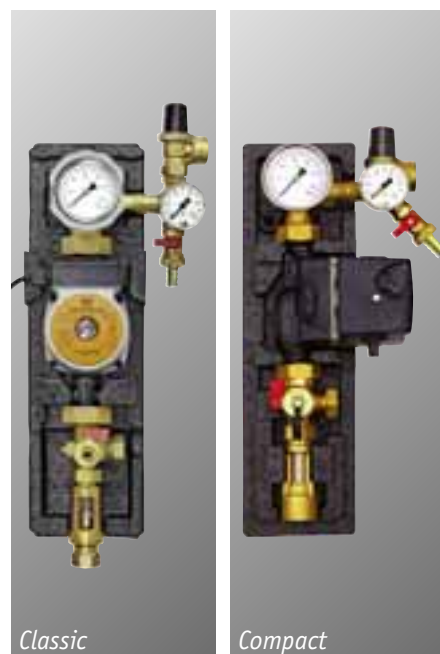

Collector area up to **12sqm**

Dual Solar Station

Installed into both 'flow' and 'return' lines from the cylinder/store and roof collector this 'Dual Line Pump Station' is available in either 'Classic' or 'Compact' versions. It is supplied complete with a Grundfos solar circulating pump with a 2 metre connecting cable. (Classic: 'Low Energy' Solar 25 - 65 DN25 EL 180mm, Compact: 'Low Energy' Solar 15 - 65 DN 25 130mm)

Included within the 'return' is a 3-way directional distributor that incorporates a manually adjustable non-return and isolating ball valve together with an over pressure relief valve (6bar). The pump station also features twin thermometer heads with a display range of 20 - 150°C as well as a system pressure gauge.

A connection point for a solar rated expansion vessel is located within a further distributor, which also includes an isolating ball valve, that is fitted above the volumetric flowmeter.

It is supplied complete with flow and return filling points with dedicated isolating ball

valves for system commissioning purposes.

The 'flow' line incorporates a further manually adjustable non-return and isolating ball valve at the temperature head and also features a permanent 'air catcher'.

This, easy to install, solar pump station unit is supplied complete with a 2 part EPP insulated cover.

Features

- 'Over pressure' safety relief valve
- Manually adjustable non-return and isolating ball valves
- Flow and return filling points
- Grundfos 'Low Energy' solar rated circulating pump
- Permanent 'air catcher'
- 3/4" BSP connections
- Volumetric flowmeter
- Connection point for a solar rated expansion vessel
- System pressure gauge
- 2 part EPP insulated cover
- Classic and Compact versions available
- Ideal for use with solar 'Essential' controller
- Collector area: up to 12sqm.

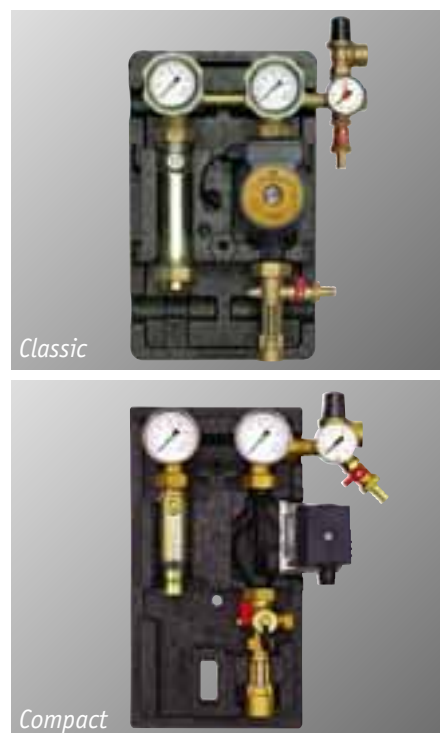

Collector area up to **12sqm**

East/West Solar Station

This 'E/W Pump Station' is installed into the 'return' line from the cylinder/store to the roof collectors. It splits the 'return' so each individual pump is responsible for circulation within either the east or west facing panels to which it has been connected. It comes supplied complete with a pair of Grundfos 'Low Energy' Solar 25 - 65 DN25 EL 180mm circulating pumps both with a 2 metre connecting cable.

Included within one 'return' line is a 3-way directional distributor that incorporates a manually adjustable non-return and isolating ball valve together with an over pressure relief valve (6bar) and a connection point for a solar rated expansion vessel.

The second 'return' line has a further manually adjustable non-return and isolating ball valve at the temperature head. This pump station features twin thermometer heads with a display range of 20 - 150°C as well as a system pressure gauge, also included are isolating ball valves that are fitted above each of the volumetric flowmeters.

It comes supplied complete with two 'flow' and two 'return' filling points, one pair for each circuit, with dedicated isolating ball valves for system commissioning purposes.

This, easy to install, solar pump station unit is supplied complete with a 4 part EPP insulated cover.

Features

- Suited to east/west orientated solar systems
- 'Over pressure' safety relief valve
- Manually adjustable non-return and isolating ball valves
- Flow and return filling points for each circuit
- Twin Grundfos 'Low Energy' solar rated circulating pumps
- 3/4" BSP connections
- Volumetric flowmeters
- Connection point for a solar rated expansion vessel
- System pressure gauge
- 4 part EPP insulated cover
- Ideal for use with solar 'View' controller
- Collector area: up to 12sqm.

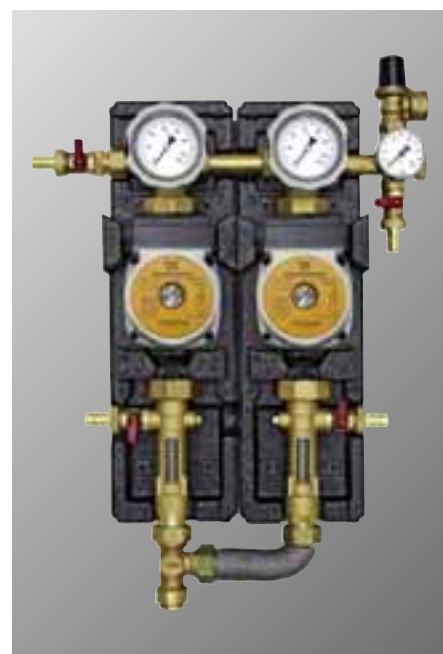

Collector area up to **12**sqm

Dual Solar Split Station

This 'Dual Split Solar Station' is installed into the 'flow' and 'return' lines from the roof collectors and the cylinder/store via a heat exchanger that splits and isolates the system into two, one side solar the other potable water.

A choice of two alternative sizes of heat exchanger are available, 16 plate (3.7kW) or 20 plate (5kW). It comes supplied complete with a Grundfos 'Low Energy' Solar 25 - 65 DN 25 EL 180mm circulating pump with a 2 metre connecting cable.

Included within the 'return' is a 3-way directional distributor that incorporates a manually adjustable non-return and isolating ball valve together with an over pressure relief valve (6bar) and a connection point for a solar rated expansion vessel. The pump station also features twin thermometer heads with a display range of 20 - 150°C as well as a system pressure gauge and a further manually adjustable non-return and isolating ball valve at the 'flow' temperature head.

It is supplied complete with flow and return filling points with dedicated isolating ball valves for system commissioning purposes and rapid h/e air bleeders.

This, easy to install, solar pump station unit is supplied complete with a 2 part EPP insulated cover.

Features

- Split system heat exchangers either 3.7 or 5kW
- 'Over pressure' safety relief valve
- Manually adjustable non-return and isolating ball valves
- Flow and return filling points
- Grundfos 'Low Energy' solar rated circulating pump
- 3/4" BSP connections
- Volumetric flowmeter
- Connection point for a solar rated expansion vessel
- System pressure gauge
- 2 part EPP insulated cover
- Collector area: up to 12sqm.



Collector area up to **12**sqm

Controls

The 'Essential' and 'View' Solar Controllers are suited for many alternative solar applications and are compatible with all solar pump station types.

They feature excellent and easily identifiable visual readings/displays e.g. cylinder and collector temperatures, pump status and if required kW/h gain (other system components will be required) also including new security features to protect against 'tampering' and have a backlit display for clarity of reading/operation.

Having the added benefit of remote mounting, the wiring can easily be run to allow siting of the controller in any convenient location away from the pump station allowing far greater flexibility and ease of install to fully suit the needs of the end user.

Features

- Very easy to install, set up and operate
- Security features to resist tampering
- Collector and cylinder sensors included
- Backlit display
- Modulating pump speed for auto system flow setting
- Pre-set options or adjustable to suit many system configurations
- Large screen display showing collector and cylinder temperature, pump status and total run time
- Advanced options to allow kWh yield data capture with additional flowmeter and sensor (View Controller only)
- View Solar Controller suited to east/west systems or systems with multiple pumps/tanks.



Pipe Work Options

Solar S Pipe work

A range of single insulated pipe work in lengths of 20 metres. Competitively priced and suitable to use with Solar S fittings. Easy selection 1st and 2nd fix pipe kits now available. Solar S pipe range includes pressing tools and universal pipe clips.

Features

- DN16/20 available
- 0.3mm pipe thickness
- Double anneal pipe
- UV coated EPDM insulation
- 3 corrugations crushed allow a bend direct from the fixing joint
- Operating temperatures up to 230°C
- Pipe clip system also available
- Compatible with **Solar S fittings**
- Easy selection 1st and 2nd fix kits now available.

Inoflex Double Pipe work

Inoflex is a premium pipe work and is available in a double pipe configuration and is supplied in 10 or 15 pipe lengths of corrugated pipe. The pipes are protected in a UV insulation and come fully loaded with sensor to control cable integrated into the insulation.

Features

- DN16/20 available
- Double pipe work
- Cable integrated into insulation
- UV coated
- Operating temperatures up to 200°C
- TUV and DVGW tested
- Universal pipe clips available
- Suitable to use only with **Fixlock® fittings**.



Pipe and Pump Connections

Solar S Fittings

A wide range of **Solar S** fittings to suit pipe work, pump connections, solar panels and cylinder jointing.

Features

- Suitable to use with Solar S pipe
- Fittings to withstand high temperatures exceed 170°C norms
- Comprehensive range of fittings suitable for all areas of the system

Fixlock®

Time saving tool – free, rapid screw joint for **Inoflex** corrugated pipe. Operating temperature up to 200°C.

- Tool free fitting
- Rapid screw connection onto Inoflex pipe
- Operating temperature up to 200°C
- Available in DN16, DN20.

Solar Xpress

Solar Xpress fittings are suitable for commercial applications and are designed to be used internally for airing cupboard or cylinder room connections; this provides another option for solar connection solutions. (Separate catalogue available)

- Savings on installation time on large scale compared to traditional jointing methods
- Completely heat free jointing
- Perfectly clean internal bore – less finishing required.



Accessories

Fill/flush system

Meibes offers a number of accessories that allow the system to be easier to maintain and to allow the pump station to work to its optimum performance. Powerfill is a light weight filling and flushing unit providing the installer with a mobile solution.

Features

- Proven German technology
- No. 1 in filling/flushing in the market
- Portable unit weight only 14kg
- Available in 110V and 230V options.

Expansion vessel

Expansion vessel suitable for solar applications. Available in popular 18 litres size and complemented by a wall bracket and service valve with connection hose.

- Non-replaceable diaphragm according to DIN 4807 norm part 3 max. operating temperature 70°C
- Exceeds EC norms for pressure vessels 70°C
- Tried and trusted "Reflex" technology.

Solar media (Glycol)

Formulated for use in solar thermal systems, tested to extreme temperature +300°C. Environmentally friendly – biodegradable. Available in 10 litres and 20 litres.

- >200°C rated corrosion inhibitors
- Formulated to withstand stagnation
- Exceeds BS 6580 corrosion standards
- Non-hazardous for storage.



SolarStation

Pump stations



Compact Solar Pump Station Single Line

<i>Model</i>	<i>Dimensions in mm (H x W x D)</i>	<i>Order code</i>
Compact SS1 Single Pump Station Grundfos 15-65 130mm	385 x 170 x 185	687002



Compact Solar Pump Station Dual Line with Air Catcher

<i>Model</i>	<i>Dimensions in mm (H x W x D)</i>	<i>Order code</i>
Compact SD1 Dual Pump Station Grundfos 15-65 130mm	385 x 300 x 185	687014



Classic Solar Pump Station Single Line

<i>Model</i>	<i>Dimensions in mm (H x W x D)</i>	<i>Order code</i>
Classic SS2 Single Pump Station Grundfos 25-65 180mm	500 x 200 x 170	687031



Classic Solar Pump Station Dual Line with Air Catcher

<i>Model</i>	<i>Dimensions in mm (H x W x D)</i>	<i>Order code</i>
Classic SD2 Dual Pump Station Grundfos 25-65 180mm	500 x 315 x 246	687044

Classic Solar Pump Station East West

<i>Model</i>	<i>Dimensions in mm (H x W x D)</i>	<i>Order code</i>
Classic SDEW East-West Pump Station Grundfos 25-65 180mm	500 x 370 x 246	687049



Classic Solar Pump Station with Heat Exchanger

<i>Model</i>	<i>Dimensions in mm (H x W x D)</i>	<i>Order code</i>
Classic SDX1 Pump Station with Heat Exchanger 3.7kw D Grundfos 25-65 180mm	500 x 315 x 246	687055
Classic SDX1 Pump Station with Heat Exchanger 5kw D Grundfos 25-65 180mm	500 x 315 x 246	687059



Solar controls

Solar Essential Control

<i>Model</i>	<i>Order code</i>
Essential solar controller	687124



Solar View Control

<i>Model</i>	<i>Order code</i>
View solar controller	687126



Pipe and fittings

Solar S pipework and Solar S fittings provide a comprehensive and competitive pricing solution, and include tools and accessory options.

Pipework



"Solar S" Single Pipework & UV Insulation

Model	Size	Lengths (m)	Order code
Single Pipe UV Ins	DN16	20	687223
Single Pipe UV Ins	DN20	20	687224



"Solar S" Pipework Kit

Model	Order code
1st Fix Kits (Panel to internal)	687225
1. Insulated Pipe DN16 inc Nuts (3/4" x 2m) x 2	<i>Suits panel without sensor pocket and with 3/4" male connection.</i> (Add Solar S fittings to suit other various panel connections)
2. Solar Panel Tee x1	
3. Solar Panel Elbow x1	
4. Panel Temperature Pocket x1	
5. Panel High Temp Sensor x 1	
6. Washer x 6	



Model	Order code
2nd Fix Kits (Internal to cylinder)	687226
1. Insulated Pipe (3/4" x 20m) x 1	<i>Suits 3/4" connections for pumps stations and cylinders with 3/4" female connections</i> (Add Solar S fittings to suit other various cylinder connections)
2. Female Union 3/4" x 10	
3. Male Connection 3/4" x 2	
4. Tee Drain 3/4" x 1	
5. Double Nipple x 4	
6. Washer x 10	

Pipework tools



"Solar S" Pipe Press

Model	Order code
Mini Pipe Press	687229
Power Pipe Press (CAT)	687230
Pipe Cutter	687231



Pipe Clips (Universal)

Model	Order code
Single Pipe Clips	687227
Double Pipe Clip	687228

Pipework fittings

"Solar S" Connection Fittings for Solar S Pipework

Model	Size	Order code
Female Union 3/4"	DN16	687232
Female Union 1"	DN20	687233



Model	Size	Order code
Male Union 3/4"	DN16	687235
Male Union 1"	DN20	687236



Model	Size	Order code
Double Nipple DN16-G3/4"	DN16	687237
Double Nipple DN20-G1"	DN20	687238



Model	Size	Order code
Fibre Washer 3/4" 16 x 24 x 2,0mm	3/4"	687240
Fibre Washer 1" 20 x 30 x 2,0mm	1"	687241



"Solar S" Connection Fittings for Collector, Cylinder

Model	Size	Order code
Female Connection 3/4" BSP - 22mm	3/4"	687243
Male Connection 3/4" BSP - 22mm	3/4"	687244



"Solar S" Connection Fittings for Pump, Cylinder

Model	Size	Order code
Adaptor with O ring 3/4" - 3/4" M-M	3/4"	687245
Drain Tee	3/4"	687246



Pipe and fittings (tool free)

Inoflex pipework Fixlock connections provide time saving fixing solution without any need for tools to compress pipe.

Pipework



"Inoflex" Double Pipework & UV Insulation inc. Sensor Wire

Model	Size	Lengths (m)	Order code
Double Pipe /UV Ins Wire	DN16	10	687192
Double Pipe /UV Ins Wire	DN20	10	687194

Pipe connections



"Fixlock" Connection Set for Inoflex Pipe

Model	Size	Order code
Fixlock Con Set Flat Seal DN16	DN16	687200
Fixlock Con Set Flat Seal DN20	DN20	687201



"Fixlock" Connection Fittings for Panel, Cylinder

Model	Size	Order code
Fixlock Female Con Set PTFE DN16	DN16	687204
Fixlock Female Con Set PTFE DN20	DN20	687205
Fixlock Male Con Set PTFE DN16	DN16	687206
Fixlock Male Con Set PTFE DN20	DN20	687207



"Fixlock" Pump Connector

Model	Order code
Fixlock 3/4" x 3/4" Pump Connector	667210

Accessories

Accessories – filling and flushing

Powerfill - Mobile Filling, Flushing Unit

Model	Order code
Powerfill 110V - Mobile Filling, Flushing Unit	687119
Powerfill 230V - Mobile Filling, Flushing Unit	687120



Solar Manual Filling Pump

Model	Order code
Solar Manual Filling Pump	687121



Accessories - solar thermal system fluid

Solar Thermal System Fluid 10 litres

Model	Order code
Glycol 10 litres	687221



Solar Thermal System Fluid 20 litres

Model	Order code
Glycol 20 litres	687222



Accessories – expansion vessel system

Expansion Vessel

Model	Size	Order code
Solar Rated Expansion Vessel	18 litres	687220



Wall Bracket Kit for Expansion Vessel

Model	Order code
Wall Bracket Kit & Service Coupler for Expansion Vessel	687122
Service Coupler (Individual)	687123



Compact Solar Pump Stations (Single & Dual)

Connections	Solar circuit	3/4" Female (Internal thread)	
	For expansion vessel	3/4" Male (Internal thread)	
Maximum allowable temperature	+120°C short term -140°C (note allowable temperature of the pump!)		
Maximum allowable pressure	10bar (note pick up pressure of safety valve)		
Non-return valve	Single 1 x 300mmWs		
	Dual Line 2 x 300mmWs		
Volumetric flow indicator	Combination scale	Propylene glycol 40%	:0.8....10.3l/min
		Water	:1....13l/m
A measuring capsule can be installed for recording the output or yield (to be adjusted on site) instead			
Thermometer	Display range 20°C.....150°C		
Pressure gauge	Display range 0....10bar		
Safety valve	Pick up pressure 6bar	20°C-150°C	
Dimension	Centre to centre	:100mm	
	Height of insulation	:385mm	
	Total width	:300mm (Single line: 170mm)	
	Depth of insulation	:185mm	

Classic Solar Pump Stations (Single & Dual)

Connections	Solar circuit	3/4" Female (Internal thread)	
	For expansion vessel	3/4" Male (Internal thread)	
Max Allowable temperature	+110°C short term - 130°C (note max allowable temp of the pump)		
Max Allowable pressure	10bar (note pick up pressure of safety valve)		
Non-return valve	Single 1 x 500mmWs		
	Dual line 2 x 500mmWs		
Volumetric flow indicator	Combination scale	Propylene glycol 40%	:0.8....10.3l/min
		Water	:1....13l/m
A measuring capsule can be installed for recording the output or yield (to be adjusted on site) instead			
Thermometer	Display range 20°C.....150°C		
Pressure Gauge	Display range 0....10bar		
Safety Valve	Pick up pressure 6bar	20°C-150°C	
Dimension	Centre to centre	:125mm	
	Height of insulation	:500mm	
	Total width	:315mm (Single line: 200mm)	
	Depth of insulation	:246mm (Single line: 170mm)	

East West Solar Pump Station

Connections	Solar circuit	3/4" Female (Internal thread)	
	For expansion vessel	3/4" Male (Internal thread)	
Maximum allowable temperature	+120°C short term -140°C (note allowable temperature of the pump!)		
Maximum allowable pressure	10bar (note pick up pressure of safety valve)		
Non-return valve	Single 1 x 300mmWs		
	Dual line 2 x 300mmWs		
Volumetric flow indicator	Combination Scale	Propylene glycol 40%	:0.8....10.3l/min
		Water	:1....13l/m
A measuring capsule can be installed for recording the output or yield (to be adjusted on site) instead			
Thermometer	Display range 20°C.....150°C		
Pressure gauge	Display range 0....10bar		
Safety valve	Pick up pressure 6bar	20°C–150°C	
Dimension	Centre to centre	:100mm	
	Height of insulation	:430mm	
	Total width	:370mm	
	Depth of insulation	:175mm	

Solar Split Pump Stations

Connections	Primary solar circuit	3/4" Female (Internal Thread)	
	Secondary circuit	1" Female	
	For expansion vessel	3/4" Male (Internal thread)	
Maximum allowable temperature	+110°C short term – 130°C (note Maximum allowable temperature of the pump)		
Maximum allowable pressure	10bar (note pick up pressure of safety valve)		
Non-return valve	Single 1 x 500mmWs		
	Dual line 2 x 500mmWs		
Thermometer	Display range 20°C.....150°C		
Pressure gauge	Display range 0....10bar		
Safety valve	Pick up pressure 6bar	20°C–150°C	
Dimension	Centre to centre	:125mm	
	Height of insulation	:500mm	
	Total width	:315mm	
	Depth of insulation	:246mm	
Medium	Primary	Propylene glycol 40% (primary)	
	Secondary	Water (secondary)	

Controls

Specification

CONTROL PANEL HOUSING	
Material	100% recyclable ABS casing for wall mounted installation
Dimensions (in mm)	175 (H) x 134 (W) x 56 (D)
Weight	360g
Enclosure	Type 1
CONTROL PANEL ELECTRICAL VALUES	
Operating voltage	230V AC, 50/60Hz, 1A
Radio interference level	N (EN 55014, VDE 0875)
Maximum cable cross-section	2.5mm ² fine-strand/single-strand 240V AC connections
Temperature sensor	PT1000
Temperature range	1.000 kΩ at 32°F
Testing voltage	4 kV 1 min (EN 60730/DIN, VDE 0631, IEC 60664/IEC)
Switching output	240V AC, 1A, 1A FLC, 6A LRC, cos φ = 0.7-1.0
Fuse protection	Micro-fuse 5 x 20mm, 2 A/T (2 amp, fine-wire)
OTHER	
Operating temperature	OT50, max humidity 95%, non-condensing
Storage temperature	OT50

Resistance table PT1000

TEMPERATURE °C	RESISTANCE OHMS	TEMPERATURE °C	RESISTANCE OHMS
-22	882	140	1232
-4	921	158	1271
14	960	176	1309
32	1000	194	1347
50	1039	230	1385
68	1077	248	1461
86	1116	284	1535
104	1155	392	1758
122	1194		

Electrical connection

All electrical cables are connected to the unit in the lower part of the casing. The terminals on the right-hand side are those for the (low voltage) connections for the sensors. The 240V AC connections are located on the left-hand side. The figure below shows the terminal field of the device.

SOLAR VIEW

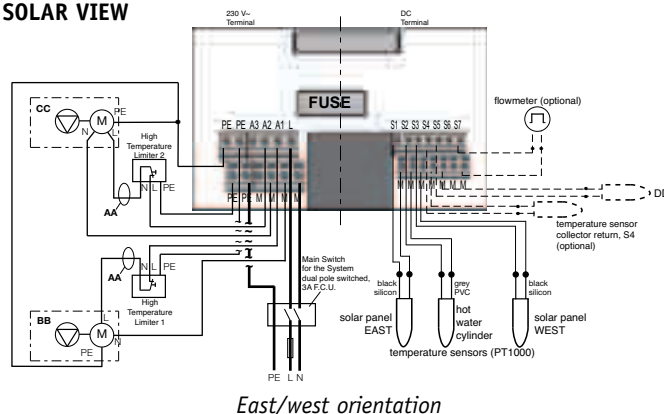

Note

- AA** These return wires should be marked as »live«.
- BB** Solar pump station, EAST solar panel
- CC** Solar pump station, WEST solar panel
- DD** An optional sensor at Terminal T5 can be used as a temperature measuring point in the cylinder to provide an output at Terminal A3 to control the switching of an alternative heat source.

SOLAR ESSENTIAL

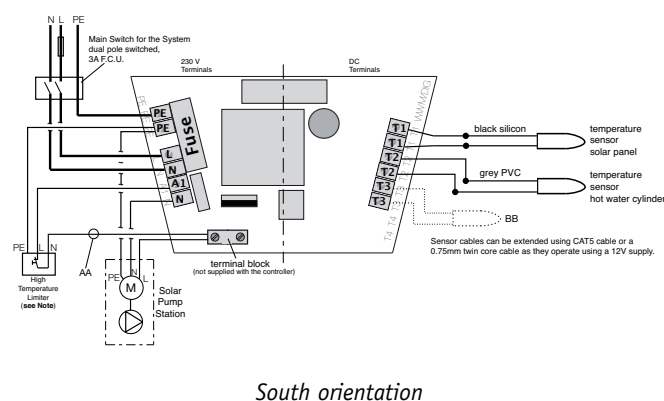

Note

- AA** This return wire should be marked as »live«.
- BB** An additional sensor in Terminal 3 can be used as a general temperature measuring point i.e. top of the cylinder.

A **High Temperature Limiter** is only required when installing a **UK pressurised** system and should be fitted at the top of the hot water cylinder.

Wall mounting

When mounting the device on a wall, proceed as follows:

- Drill the fixing holes using the drilling template (bottom).
- Screw in the two top screws leaving a gap of up to 6mm.
- Open the device as described and hang it on the two screws. You can now fit the two bottom screws.

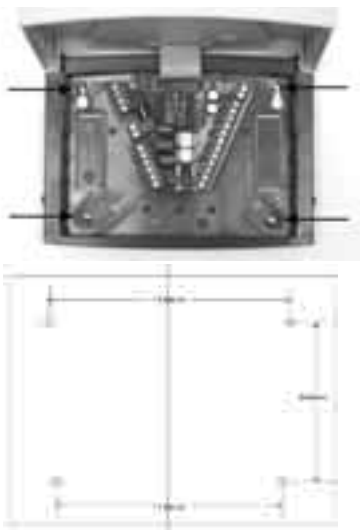

To avoid damage to the lower part of the casing, do not over tighten any of the screws.

Solar Glycol

Product	A ready-to-use heat transfer fluid for solar heating systems. Based on a blend of propylene glycol, high temperature (resistant) inhibitors and distilled water
Appearance	Clear to straw in colour
Density	1.02 - 1.03
Refractive Index	1.374
PH	8.5 - 9.5
Water content	58 - 60%
Boiling points	103°C at atmospheric pressure, rising to 142°C to 3.5bar
Frost protection	-20°C first ice crystals form, -28°C total solidification/freezing

Properties

Solar Glycol is slightly viscous, virtually odourless liquid, based on propylene glycol and has a very low order of oral toxicity. It is readily biodegradable (92% over 30 days) and thus will not remain in the environment. Solar Glycol has been specifically formulated for use in solar heating systems operating up to 200°C. Solar Glycol contains high temperature (resistant) corrosion and scale inhibitors to protect all metals commonly found in modern solar heating systems, thus ensuring a long operating life and high thermal efficiency. Solar Glycol does not normally attack the seals within a solar heating system.

Application

Solar Glycol is supplied ready-to-use and therefore does not require on-site dilution. To maintain system integrity only top-up with Solar Glycol and do not mix with other heat transfer fluids. Propylene glycol can sustain temperatures up to 170°C for prolonged periods and below 200°C for short periods. Sustained temperatures above 170°C will lead to premature degradation of the propylene glycol and temperatures above 200°C will lead to irreversible and rapid degradation.

Corrosion protection

The inhibitors within Solar Glycol provide corrosion protection to BS6580 and ASTM D1384 standards.

Health & safety

Solar Glycol is non-toxic and not subject to hazardous labelling, however all guidelines as detailed in the Material Safety data sheet should be strictly observed. Solar Glycol is not a potential water pollutant and is readily biodegradable in the environment.

Shelf Life and availability

Solar Glycol has a shelf life of at least 1 year in airtight containers stored in a cool shaded environment.

Expansion Vessel

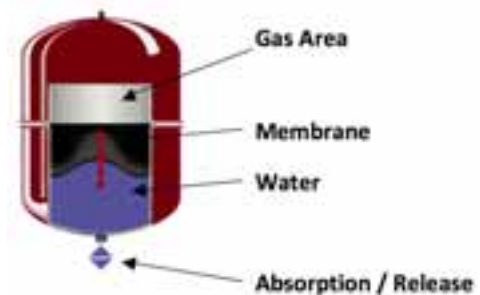

Technical - Solar Expansion Vessel	
Permanent advance temperature	120°C
Minimum operating temperature (only with addition of suitable anti freeze agent)	10°C
Maximum continuous operating temperature on the diaphragm	70°C
Pre charge/factory pressure	1.5bar
Working pressure	10bar
Gas space	Nitrogen (fluid group 2) Acc. Dir 97/23/EG
Water space	Water/Glycol mix (max 50% Glycol fraction) Acc. Dir 97/23/EG
Installation position	Vertically or horizontal (with water connection either down)

Compact Single Pump Station

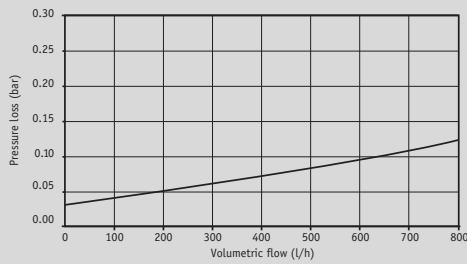

Solar Split System

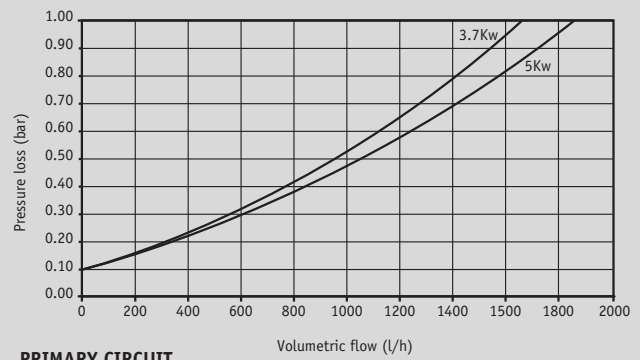

PRIMARY CIRCUIT

Compact Dual Pump Station

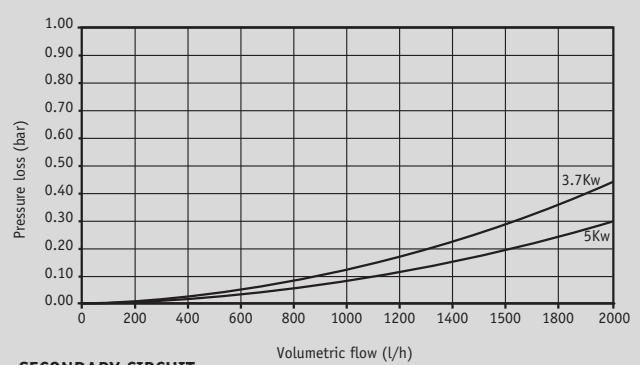
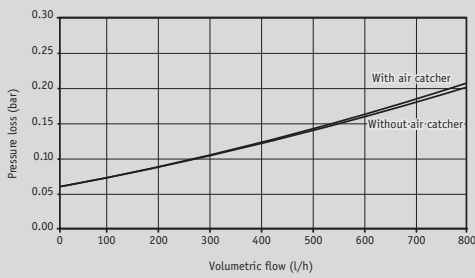

SECONDARY CIRCUIT

Classic Single Pump Station

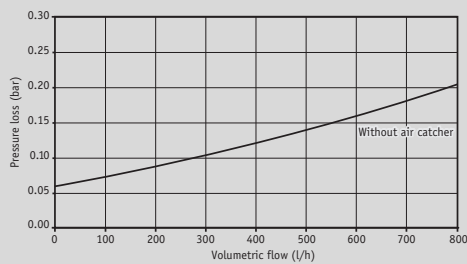

East/West Pump Station

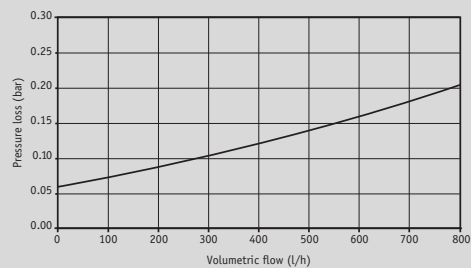

Classic Dual Pump Station

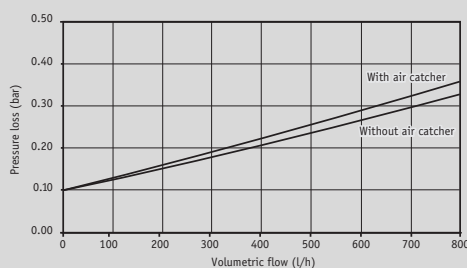

Solar commercial pump stations suit most applications for new and retrofit solutions including multi-level apartments, hotels, factories, leisure centres, prisons, schools, colleges, campuses, hospitals and catering establishments.

They save water heating costs and keep hot water distribution fresh with legionella prevention.

Solar Station XL

Includes stainless steel heat exchanger with block insulation and two circulation pumps for primary and secondary cycle. Installed on a base plate and concealed casing. Split system with solar fluid heating through the heat exchanger, in turn heating the tank reservoir cycle. 1" connections. Suitable for collectors up to 30m².

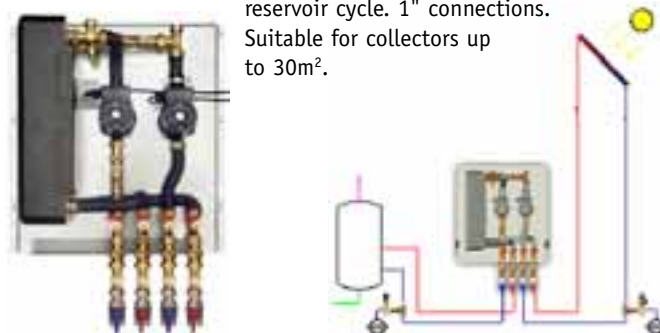

Solar Ventec

A choice of solar pumps to suit commercial applications and now complete with new generation valve technology without the need for non-return valves and still providing 100% prevention if gravity circulation.

Provides excellent performance with up to 22m² collector sizes.

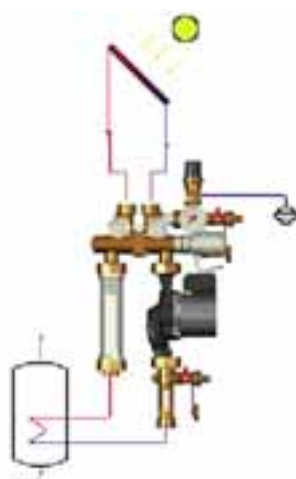

Solar Station XXL

Includes stainless steel heat exchanger with block insulation. Two large circulation pumps for primary and secondary cycle. Installed with aluminium frame. Split system with solar fluid heating through the heat exchanger, in turn heating the tank reservoir cycle. 1 1/4" connections. Suitable for collectors between the sizes of 95m² to 150m².

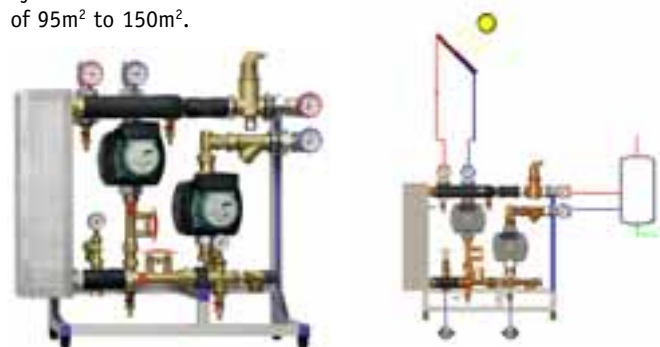

Solar Station L

Dual line solar pump station with a choice of high performance DN 25 rated pumps with 1" connections. Provides all the benefits and features of a domestic solar station whilst suiting

large surface collectors reaching up to sizes of 50m².

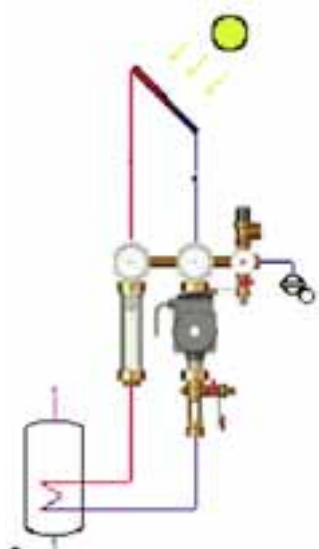

Press-fit solutions for solar water heating systems

XPRESS Solar fittings from Pegler Yorkshire makes jointing in solar water heating systems easier, faster and more cost effective than other jointing methods – a fittings system which simply presses together in seconds to create a perfect joint, every time.



XPRESS press-fit: cost-effective jointing for solar applications

Pegler Yorkshire's innovative and comprehensive XPRESS Solar range delivers all the benefits of a heat-free, press-fit jointing system.

XPRESS Solar also lives up to the promise of its name in every respect: a method which is easy, fast and highly cost-effective, simply pressing together in seconds to create a perfect joint every time, with the guarantee of uncontaminated installation.

XPRESS Solar fittings are suitable for use with most proprietary propylene glycol heat transfer fluids in concentrations of up to 40%.

So many XPRESS Solar benefits, and so much choice

- Major savings in installation time and cost compared with traditional jointing methods
- A completely heat-free jointing system that requires no additional solders, adhesives, compounds, tools, accessories, gas, hot works permit or extra and costly insurance
- Clean, rapid, heat-free jointing: no complicated clamping techniques or long preparation procedures or waiting for adhesive to dry
- Safety: no naked flames
- Perfectly clean internal bore – so less finishing or cleaning required
- No localised annealing from high-temperature working
- No carbon deposits – so less risk of corrosion
- System does not need to be 'dry' for effective jointing
- Electrical continuity assured when the XPRESS jointing process is complete.

Standards and approvals



ISO is achieved through the continuous improvement of our Quality Management System in line with the requirements of BS EN ISO9001: 2000.

Guarantees

25 year guarantee

The XPRESS Solar range is guaranteed against all manufacturing defects for 25 years when installed along with other manufacturers' pipeline components conforming to the specified standard.

30 year guarantee



Where pipelines are constructed exclusively from compatible XPRESS Solar fittings and tubes, the resulting installations will be deemed an XPRESS System and as such qualifies for a 30 year guarantee against all manufacturing defects.

XPRESS solar fittings, tube and accessories	Guarantee period (years)	
	25	30
Fittings	✓	-
Fittings with Yorkex* copper tube	-	✓

To qualify for guarantees, all products must be installed in accordance with our instructions on specified applications. *Yorkex is a brand name of Yorkshire Copper Tube.





Pegler Yorkshire

Our brands:



UK sales

Free Phone: 0800 156 0010
Free Fax: 0808 156 1011
Email: uk.sales@pegleryorkshire.co.uk

Export

Tel: +44 (0) 1302 855 656
Fax: +44 (0) 1302 730 513
Email: export@pegleryorkshire.co.uk

Technical Help

Free Phone: 0800 156 0015
Free Fax: 0808 156 1012
Email: tech.help@pegleryorkshire.co.uk

Brochure Hotline

Free Phone: 0800 156 0020
Free Fax: 0808 156 1011
Email: info@pegleryorkshire.co.uk

www.pegleryorkshire.co.uk

Pegler Yorkshire Group Limited

St. Catherine's Avenue, Doncaster,
South Yorkshire, DN4 8DF, England.
Tel: 0844 243 4400 Fax: 0844 243 9870

Registered in England Company No. 00401507
Registered Office: Haigh Park Road, Stourton, Leeds,
West Yorkshire, LS10 1RT, England.

All brand names and logo styles are registered trademarks.
Maintaining a policy of continual product development,
Pegler Yorkshire reserves the right to change specifications, design
and materials of products listed in this publication without prior notice.

LIT.REF: 880135.08.09

