

# **IDEAL SPRINT RS.75**

## **Wall Mounted Balanced Flue Combination Boiler Installation & Servicing**

---

### **CAUTION:**

To avoid the possibility of injury during the installation, servicing or cleaning of this appliance, care should be taken when handling the edges of sheet steel components.

**G.C. Appliance No.**

**Ideal SPRINT RS. 75**

**47 415 01**

**IMPORTANT:** This appliance is for use with **NATURAL GAS ONLY.**

---

### **NOTE TO INSTALLER:**

**LEAVE THESE INSTRUCTIONS ADJACENT TO THE GAS METER**

---

**Stelrad**  **Ideal**

**Table 1 – GENERAL DATA**

Main Burner		FURIGAS – Type 'R' 118.000.020
Gas Control Valve		HONEYWELL V 8600 N 1017
Burner Injector		BRAY 10 2200
Pilot Injector		HONEYWELL 45003 – 508 – 001 38/36A
Gas Supply Connection		Rc½ (½in.BSP/t)
Inlet Connection – DHW		15mm O.D. Copper
Outlet Connection – DHW		15mm O.D. Copper
Flow Connection – CH		22mm O.D. Copper
Return Connection – CH		22mm O.D. Copper
MAXIMUM Working Pressure (sealed system)	bar (psi)	2.65 (38.5)
MAXIMUM Static Water Head	m (ft)	27.5 (90.0)
MINIMUM Static Water Head (Open Water Systems)	m (ft)	0.45 (1.5)
MAXIMUM DHW Inlet Pressure	bar (psi)	6.0 (87.0)
MINIMUM DHW Inlet Pressure	bar (psi)	1.0 (14.5)
Electric Supply		220/240V 50 Hz
External Fuse Rating		3 Amp
Water Content	CH litre (gal)	2.9 (0.64)
	DHW litre (gal)	0.55 (0.12)
Dry Weight	kg (lb)	48.8 (107.6)
MAXIMUM Installation Weight	kg (lb)	38.8 (85.5)

**Table 2 – PERFORMANCE DATA****(a) Central Heating**

Burner Setting Pressure (Hot)	mbar	4.0	6.4	9.3	14.1
	in.w.g.	1.6	2.6	3.7	5.7
Output	kW	11.7	14.6	17.6	22.0
	Btu/h	40 000	50 000	60 000	75 000
Input	kW	14.9	18.4	22.0	27.5
	Btu/h	50 900	62 900	75 000	93 800
Gas Consumption (Hot)	l/s	0.39	0.48	0.57	0.71
	ft <sup>3</sup> /h	49.0	60.6	72.3	90.4

**(b) Domestic Hot Water**

Maximum Burner Setting Pressure (Hot)	mbar	14.1
	in.w.g.	5.7
Maximum DHW Output	kW	22.0
	Btu/h	75 000
DHW flowrate at 35°C temperature rise at minimum mains water pressure of 1.5 bar (21.5 psi) at an inlet water temperature of not greater than 7°C.	l/m	9.0
	gpm	2.0

**Notes:**

- Gas consumption is calculated using a calorific value of 38.7 MJ/m<sup>3</sup> (1 038 Btu/ft<sup>3</sup>)
- The appliance is pre-set at the factory to the lowest nominal rating

# INTRODUCTION

The IDEAL SPRINT RS. 75 is a wall mounted, low water content natural draught, balanced flue combination boiler. It is range rated to provide central heating outputs of 11.7kW (40 000 Btu/h) to 22.0 kW (75 000 Btu/h) maximum, with instantaneous domestic hot water priority at an output of 22.0 kW (75 000 Btu/h) maximum.

The boiler is designed for use with fully pumped sealed water systems, though connection to open water systems is also possible. It is supplied fully assembled with domestic hot water calorifier, diverter valve and circulating pump by-pass valve, pressure gauge, safety valve and expansion vessel. Two selector switches control the choice of service between central heating and hot water or hot water only.

An optional programmer kit is available to control the central heating.

With the HEATING switch set to OFF and the WATER switch set to ON the boiler fires only when domestic hot water is drawn off.

With both switches set to ON central heating is supplied at the required pre-set output until domestic hot water is drawn off. The boiler then fires at maximum rate and the full output is directed, via the diverter valve, to the calorifier to supply a maximum DHW output of 22.0 kW (75 000 Btu/h). At the minimum DHW draw-off rate of 3 l/min (0.7 gpm) the maximum temperature is limited to 70°C by the modulating gas control.

The boiler casing is of white enamelled mild steel with a removable smoked brown fascia. The controls compartment below the boiler has a brown enamelled mild steel cover. The boiler controls can be seen through a cut-out in the cover.

## Gas Safety (Installation and Use) Regulations 1984

It is the law that all gas appliances are installed by competent persons (e.g. CORGI, identified by ) , in accordance with the above Regulations. Failure to install appliances correctly could lead to prosecution.

It is in your own interest, and that of safety, to ensure that the law is complied with.

The installation of the boiler MUST also be in accordance with I.E.E. wiring regulations, the Local Building Regulations, the by-laws of the Local Water Undertaking and any relevant requirements of the Local Authority. Detailed recommendations are given in the following British Standard Codes of Practice.

- CP.331:3 Low pressure installation pipes.
- BS.5376:2 Boilers of rated input not exceeding 60 kW.
- BS.5449:1 Forced circulation hot water systems (smallbore and microbore domestic central heating systems).
- BS.5546 Installation of gas hot water supplies for domestic purposes (2nd Family Gases).
- BS.5440:1 Flues (for gas appliances of rated input not exceeding 60 kW).
- BS.5440:2 Air supply (for gas appliances of rated input not exceeding 60 kW).

## IMPORTANT:

This appliance is approved by the British Gas Corporation for safety and performance. It is, therefore, important that no external control devices — e.g. flue dampers, economisers, etc., — be directly connected to this appliance unless covered by these 'Installation and Servicing' instructions or otherwise recommended by Stelrad Group Ltd., in writing. If in doubt please enquire.

Any direct connection of a control device not recommended by Stelrad Group Ltd., could invalidate the B.G.C. approval and the normal appliance warranty and could also infringe the Gas Safety Regulations and above Regulations.

Manufacturer's notes must NOT be taken, in any way, as over-riding statutory obligations.

## LOCATION OF BOILER

The boiler MUST be installed on an external wall. The wall MUST be flat and vertical, and capable of adequately supporting the weight of the boiler and any ancillary equipment.

The boiler may be fitted on a combustible wall and insulation between the wall and the boiler is not necessary — unless required by the local authority.

## IMPORTANT NOTICE

If the boiler is to be fitted in a timber framed building it should be fitted in accordance with the British Gas publication 'Guide for Gas Installations in Timber Frame Housing'. Reference DM2. If in doubt advice must be sought from the Local Gas Region of British Gas.

The boiler may be installed in any room or internal space, although particular attention is drawn to the requirements of the I.E.E. Wiring Regulations and, in Scotland, the electrical provisions of the Building Regulations applicable in Scotland with respect to the installation of the boiler in a room or internal space containing a bath or shower.

Where installation will be in an unusual location special procedures may be necessary and BS.5376:2 gives detailed guidance on this aspect.

A compartment used to enclose the boiler MUST be designed and constructed specially for this purpose. An existing cupboard, or compartment, may be used provided it is modified for the purpose.

Details of essential features of cupboard/compartment design, including airing cupboard installations, are given in BS.5376:2.

In siting the boiler, the following limitations MUST be observed:

1. The position selected for installation MUST allow adequate space for servicing in front of the boiler and for air circulation around the boiler.
2. This position MUST also permit the provision of a satisfactory balanced flue termination.

## GAS SUPPLY

The Local Gas Region should be consulted, at the installation planning stage, in order to establish the availability of an adequate supply of gas.

An existing service pipe must NOT be used without prior consultation with the Local Gas Region.

A gas meter can only be connected by the Local Gas Region, or by a Local Gas Region Contractor.

An existing meter should be checked, preferably by the Gas Region, to ensure the meter is adequate to deal with the rate of gas supply required.

Installation pipes should be fitted in accordance with CP.331:3.

Pipework from the meter to the boiler must be of an adequate size.

Do NOT use pipes of a smaller size than the boiler inlet gas connection.

The complete installation MUST be tested for gas soundness and purged as described in the above Code.

## FLUING

Detailed recommendations for fluing are given in BS.5440:1.

The following notes are intended for general guidance.

1. The boiler MUST be installed so that the terminal is exposed to the external air.
2. It is important that the position of the terminal allows the free passage of air across it at all times.
3. The minimum acceptable spacings from the terminal to obstructions and ventilation openings are specified in Table 3.

**Table 3**

Terminal Position	Minimum Spacing Natural Draught
1. Directly below an openable window, air vent or any other ventilation opening.	300mm (12in)
2. Below guttering, eaves, drain-pipes or soil pipes	300mm (12in)
3. Below balconies	600mm (24in)
4. Above adjacent ground or balcony level	300mm (12in)
5. From vertical drain pipes or soil pipes	75mm (3in)
6. From internal or external corners	600mm (24in)
7. From a surface facing the terminal	600mm (24in)
8. From a terminal facing the terminal	600mm (24in)

4. Where the lowest part of the terminal is fitted less than 2m (6.6ft) above a balcony, above ground, or above a flat roof to which people have access, the terminal MUST be protected by a purpose designed guard.

Terminal guards are available from:

Quinnel, Barret & Quinnet Ltd., 884 Old Kent Road, London SE 15, and from Tower Flue Components Ltd. Vale Rise, Tonbridge, Kent. TN9 1TB.

5. Where the terminal is fitted within 850mm (34in) of a plastic or painted gutter, or 450mm (18in) of painted eaves, an aluminium shield of at least 750mm (30in) long should be fitted to the underside of the gutter or painted surface.

6. The air inlet/products outlet duct and the terminal of the boiler MUST be NOT closer than 25mm (1in) to combustible material.

Detailed recommendations on protection of combustible material are given in BS.5440:1 1978, sub-clause 20:1.

**IMPORTANT:**

It is absolutely ESSENTIAL to ensure, in practice, that products of combustion discharging from the terminal cannot re-enter the building, or any other adjacent building, through ventilators, windows, doors, other sources of natural air infiltration, or forced ventilation/air conditioning.

If this eventuality should occur, the appliance MUST be turned OFF IMMEDIATELY and the Local Gas Region consulted.

**TERMINAL**

The terminal assembly of balanced flue can be adapted to accommodate various wall thicknesses – refer ‘Packaging’.

**AIR SUPPLY**

Detailed recommendations for air supply are given in BS.5440:2. The following notes are intended for general guidance:

1. It is NOT necessary to have a purpose provided air vent in the room or internal space in which the boiler is installed.

2. If the boiler is to be installed in a cupboard or compartment, permanent air vents are required (for cooling purposes) in the cupboard/compartment, at both high and low levels.

The air vents must either communicate with a room/

internal space, or be direct to outside air.

The minimum effective areas of the permanent air vents, required in the cupboard/compartment, are specified below and are related to the maximum rated heat input of the boiler.

**Table 4**

Position of air vent	Air from room /internal space	Air direct from outside
HIGH $\text{cm}^2$	248	124
LEVEL $\text{in}^2$	38	19
LOW $\text{cm}^2$	248	124
LEVEL $\text{in}^2$	38	19

**Note:** Both air vents MUST communicate with the same room or internal space, or MUST both be on the same wall to outside air.

**WATER CIRCULATION SYSTEM**

The boiler is suitable for connection to sealed water and open vent central heating systems. The domestic hot water (DHW) calorifier is incorporated within the boiler casing and only requires connection to the mains water supply.

The central heating system should be in accordance with the relevant recommendations given in BS.5376:2 and, in addition, for Smallbore and Microbore systems – BS.5449:1.

The domestic hot water system should be in accordance with the relevant recommendations of BS.5546.

Copper tubing, to BS.2871:1, is recommended for water carrying pipework, and MUST be used for pipework carrying potable water.

Ancillary pipework, not forming part of the useful heating surface, should be lagged to prevent heat loss and any possible freezing, particularly where pipes run through roof spaces and ventilated under-floor spaces.

Draining taps should be at least 1/2in.BSP nominal size and be in accordance with BS.2879.

The hydraulic resistances of the boiler (including the diverter valve and all internal pipework) are given in Table 5.

**Table 5**

Boiler Output	kW Btu/h	11.7 40 000	14.6 50 000	17.6 60 000	22.0 75 000
Water flow rate	l/min gal/h	15.2 200	19.0 250	22.8 300	24.7 326
Temperature differential	$^{\circ}\text{C}$ $^{\circ}\text{F}$	11 20	11 20	11 20	13 23
Pressure loss	mbar in.w.g.	77 31	127 51	187 75	217 87

**ELECTRICAL SUPPLY**

Wiring external to the appliance MUST be in accordance with the current I.E.E. wiring Regulations and any Local Regulations which apply.

The boiler is supplied for 240 V ~ 50 Hz. Single Phase.

Fuse rating is 3 A.

The methods of connection to the mains electricity supply MUST facilitate complete electrical isolation of the boiler, preferably by use of a fused three-pin plug & shuttered socket-outlet, both complying with the requirements of BS. 1363. Alternatively, a fused double-pole switch, having a 3 mm (1/8 in.) contact separation in both poles serving only the boiler, may be used.

The point of connection to the mains should be readily accessible and adjacent to the boiler, except that, for bathroom installations, the point of connection to the mains MUST be situated outside the bathroom.

**Note:** Where a room sealed appliance is installed in a room containing a bath or a shower, any electrical switch or appliance control utilising mains electricity should be situated such that it cannot be touched by a person using the bath or shower.

# INSTALLATION

Allow adequate space in front of the boiler for servicing purposes.

## PACKAGING

The boiler is supplied fully assembled and despatched in one pack, 'A' together with one of three packs – 'B', 'B1' or 'C'. Pack 'A' contains the boiler body assembly, wall fixing template, top cover plate, Instruction book and a hardware pack – containing:–

- (a) 6 off – No. 10 x 2in. lg screws
- (b) 6 off – wall plugs
- (c) a wall mounting plate
- (d) 4 off – cable clips

Keep the carton the right way up, in accordance with the markings on the outside.

Packs 'B', 'B1' and 'C' contain the terminal outlet appropriate to the wall thickness – Refer Table 6.

**Table 6 WALL THICKNESS**

Wall thickness	Packs supplied
114 – 191 mm	A + C
4½ – 7½ in	
229 – 305 mm	A + B
9 – 12 in	
318 – 394 mm	A + B1
12½ – 15½ in	

It is MOST IMPORTANT that this appliance be installed in a VERTICAL POSITION, with the flue/air duct passing through the wall in a HORIZONTAL PLANE.

A minor deviation from the horizontal is acceptable, provided that this results in a downward slope of the flue/air duct away from the boiler.

Two jacking screws, located at the bottom of the boiler back panel, are provided to facilitate boiler alignment – refer Fig.1.

The boiler is to be hung on an external wall, and the space in which it is fitted MUST have the following minimum dimensions: Refer Fig. 4.

Width	485mm	(19½in)
Depth	300mm	(12in)
Height	1050mm	(42in)

This space includes the following minimum clearances for installation and servicing:

Above the boiler	50mm (2in)
At each side of the boiler	10mm (½in)
Underneath the boiler	100mm (4in)

In addition, a minimum clearance of 450mm (18in) MUST be available at the front of the boiler to enable the appliance to be serviced.

## UNPACKING THE BOILER

- Open pack 'A' – remove the hardware pack, the top cover plate, the wall fixing template and the Instruction books.
- Lift off the outer box, leaving in position the pipe protection pad attached to the bottom of the boiler. To facilitate installation the casing must be removed.

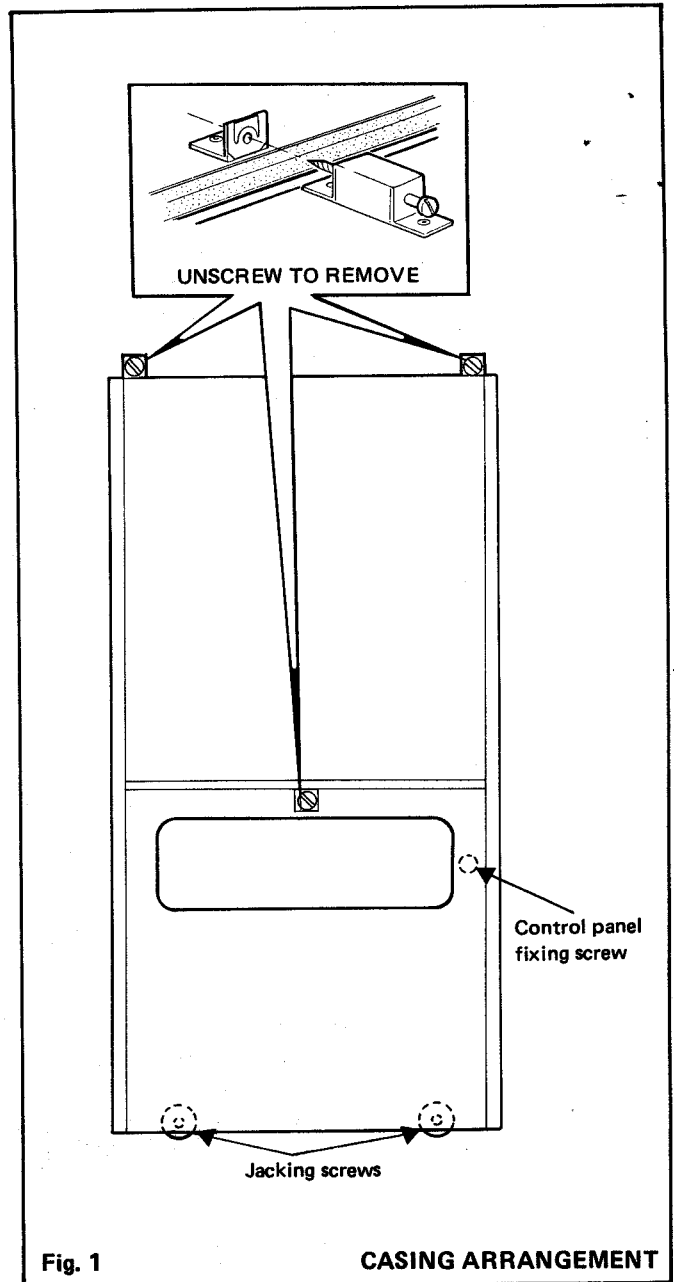

**Fig. 1**

**CASING ARRANGEMENT**

## REMOVING THE BOILER CASING

- Lift off the controls compartment front cover.
- Release the two captive screws at the top of the casing and the single captive screw within the controls compartment. Lift the casing off the boiler (refer to Fig. 1) and take care not to damage the glass fascia panel. Place the casing safely to one side.

## PREPARING THE WALL – Refer Fig. 2

- Tape the template to the wall in the selected position.
- Mark out the position of the two wall mounting plate screws, the two lower fixing screws, the two top cover plate screws and the position of the hole for the duct.
- Drill the holes with an 8mm (5/16in) masonry drill and insert the plastic plugs provided.
- Cut the appropriate hole in the wall for insertion of the terminal assembly. The terminal assembly MUST NOT come into contact with combustible material, such as that used in non-standard construction of timber framework and plasterboard etc.
- Secure the mounting plate to the wall with two of the No. 10 x 2in. screws provided.

**FITTING TO THE WALL – Refer Fig. 2**

**Note:** If the boiler is to be installed at low level, over a solid floor, it is recommended that additional clearance is allowed beneath the boiler for ease of connection. The gas and water pipes should, also, be pre-formed before fitting to the boiler.

1. Lift the boiler into position, entering the projecting air duct into the opening cut in the wall, and engaging the backplate onto the wall mounting plate lugs.
2. Remove the pipe protection pad from the bottom of the boiler.
3. Using the jacking screws located at the bottom of the boiler back panel (refer Fig. 1) adjust as necessary until the flue duct is horizontal or sloping slightly downwards – away from the boiler. Check the alignments with a spirit level.
4. Secure the lower casing to the wall with two of the No. 10 x 2in. lg. screws provided.
5. Fix the top cover plate in position, above the boiler flue duct, with the two remaining No. 10 x 2in. lg. screws.

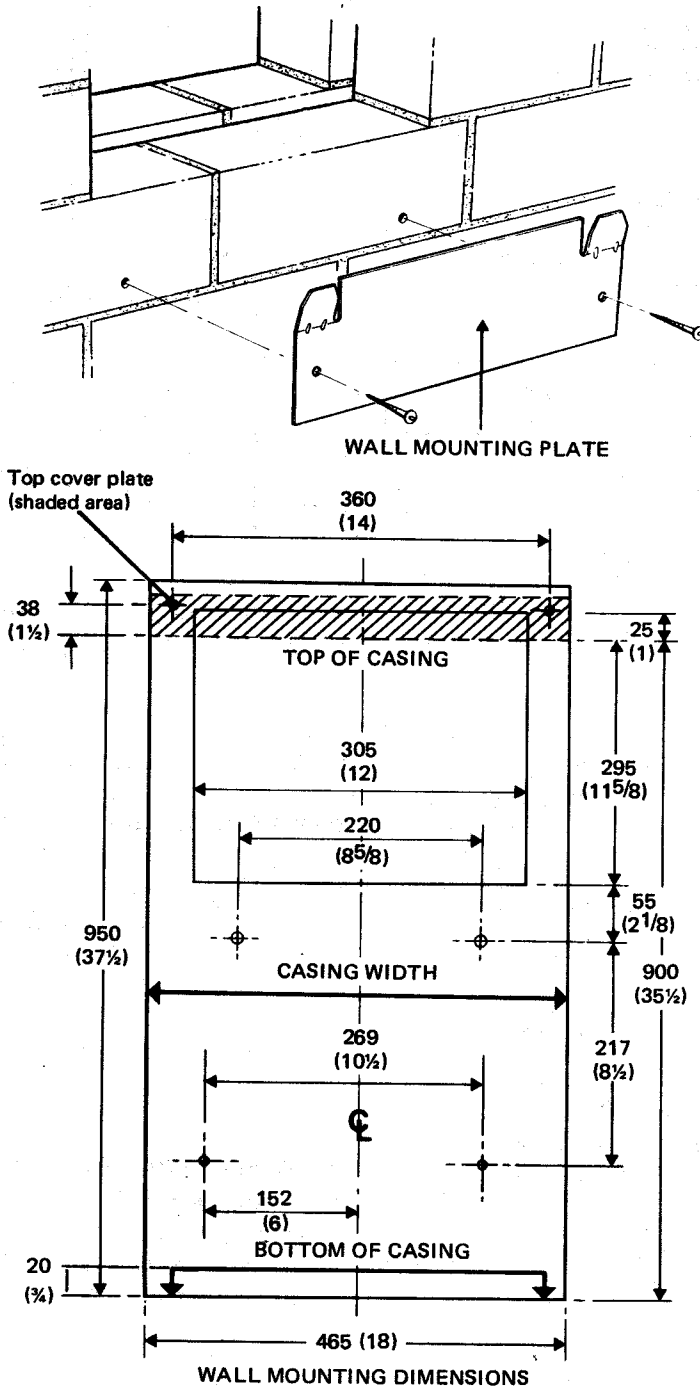
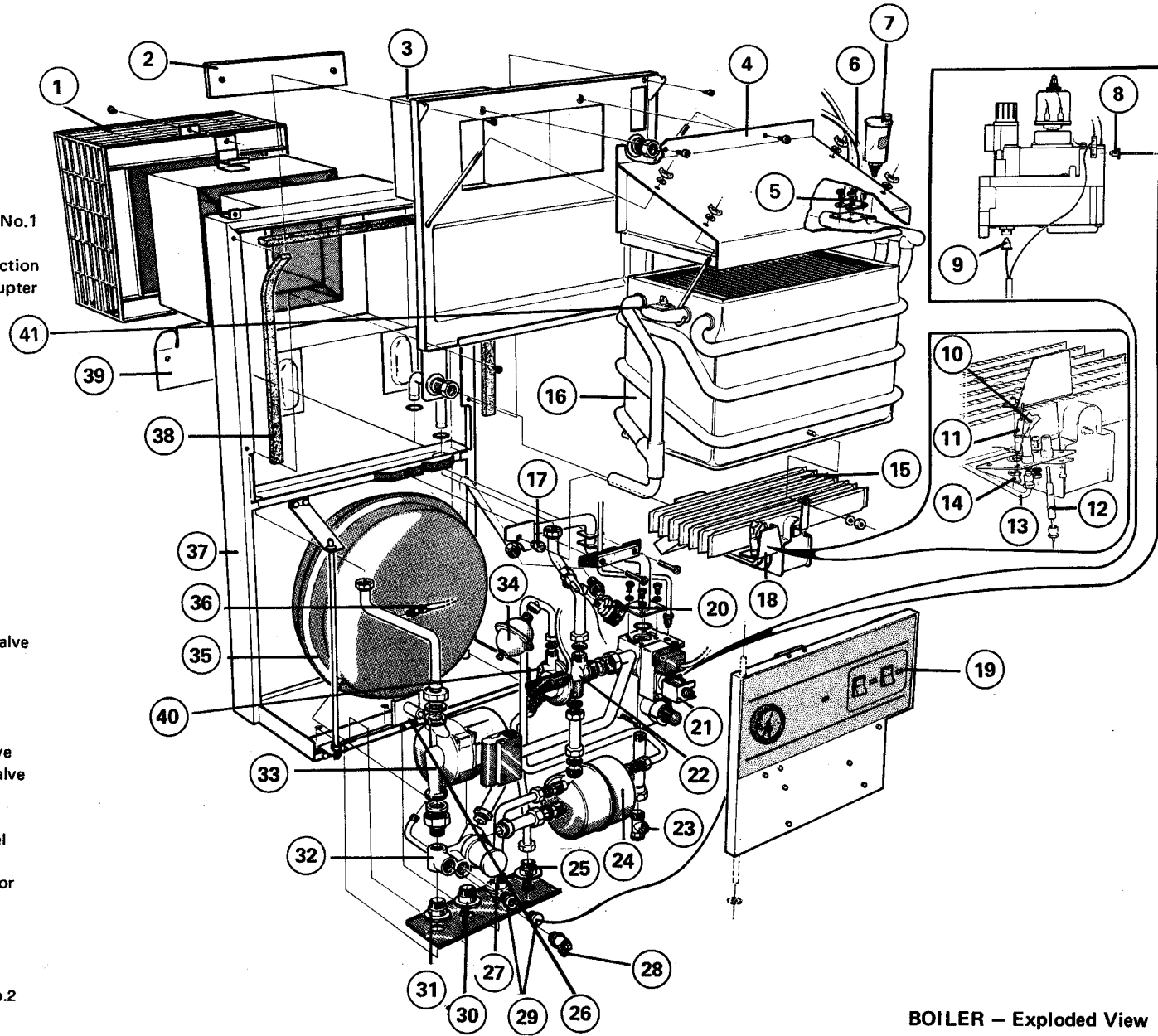

**Fig. 2**

**TEMPLATE AND WALL MOUNTING PLATE**

**LEGEND:**

1. Terminal grille
2. Top cover plate
3. Interpanel assembly
4. Collector hood
5. Control thermostat
6. Overheat thermostat No.1
7. Automatic air vent
8. Thermocouple connection
9. Thermocouple interrupter
10. Pilot burner
11. Spark electrode
12. Thermocouple
13. Pilot pipe
14. Pilot injector
15. Main burner
16. Heat exchanger
17. Main burner injector
18. Pilot burner shield
19. Control panel
20. Safety valve
21. Gas control valve
22. Diverter valve
23. Gas service cock
24. DHW calorifier
25. DHW inlet isolating valve
26. Piezo unit
27. DHW outlet
28. Drain cock
29. Pressure gauge
30. CH flow isolating valve
31. CH return isolating valve
32. By-pass valve
33. Circulating pump
34. DHW expansion vessel
35. CH expansion vessel
36. DHW thermistor sensor
37. Back panel assembly
38. Sealing strip
39. Wall mounting plate
40. DHW throttle screw
41. Overheat thermostat No.2



**BOILER – Exploded View**

All dimensions in mm (ins)

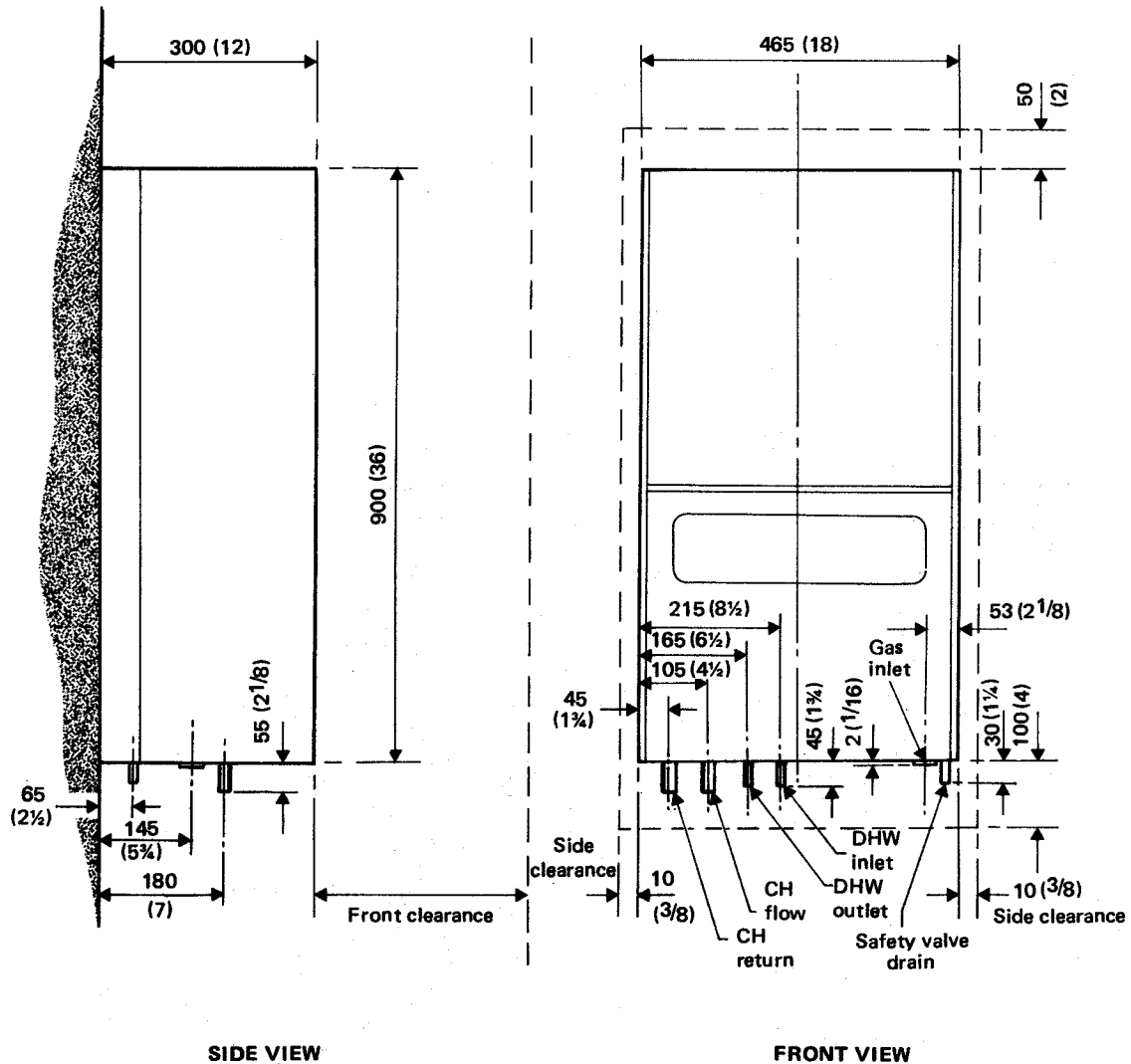

Fig. 4

DIMENSIONS

## WATER CONNECTIONS – Refer Fig. 4

### 1. Central Heating

#### Notes:

- When the boiler output exceeds 14.4 kW (49 000 Btu/h) then 28mm (in) pipes should be used, both to and from the boiler
- Before any connections are made to the boiler all system valves should be opened and the system thoroughly flushed with cold water.

#### USING COMPRESSION FITTINGS

- Connect the central heating flow pipe to the pipe end marked 'CH FLOW'.
- Connect the central heating return pipe to the pipe end marked 'CH RETURN'.
- Fill and vent the system.  
Check for water soundness.

#### Note:

When filling there may be a slight water leakage from the automatic air vent on the boiler flow header.  
Care must be taken to protect the thermostats, adjacent to the vents, from any such leakage.

### 2. DHW Supply

**Notes:** Flush out all foreign matter from the supply pipe before connecting to the appliance.

If the DHW supply is fed from a constant head tank then remove the flow regulator from the DHW OUTLET pipe, as follows:

- Disconnect the spark lead from the piezo unit.
- Withdraw the piezo unit and bracket by undoing the screws retaining the piezo unit bracket to the casing.
- Undo the unions on the pipe connecting the DHW OUTLET to the calorifier and remove the pipe.
- Lift out the flow regulator and re-assemble in reverse order.

#### USING COMPRESSION FITTINGS

- Connect the cold water supply to the pipe end marked 'DHW INLET'.
- Connect the hot water supply pipe to the pipe end marked 'DHW OUTLET'.

### 3. Safety Valve Drain

Route a 15mm OD pipe from the safety valve drain connection (bottom R.H. side of the boiler) to a position outside of the building such that any discharge of water or steam from the valve cannot create a hazard to the occupants or damage to electrical components and wiring.



## GUIDE TO SYSTEM REQUIREMENTS – Fig. 5

1. The installation must comply with the requirements of BS.5376:2 and BS.5449:1.
2. The installation should be designed to work with flow temperatures of up to 82°C.
3. All components of the system, must be suitable for a working pressure of 3 bar (45 psi) and temperature of 110°C. Great care should be taken in making all connections so that the risk of leakage is minimised. The following components are incorporated within the appliance.
  - (a) Circulating pump
  - (b) Automatic by-pass valve
  - (c) Safety valve with a non-adjustable pre-set lift pressure of 3 bar (45 psi)
  - (d) Pressure gauge covering the range 0–6 bar (0–90 psi).
  - (e) 10 litre expansion vessel with initial charge pressure of 0.75 bar

For further details refer to BS.5449:1 and British Gas Corporation publication – Specifications for Domestic Central Heating

- and Hot Water.
4. Make-up water  
Provision must be made for replacing water loss from the system either:
    - (a) from a manually filled make-up vessel with a readily visible water level. The vessel should be mounted at least 150mm (6in) above the highest point of the system and be connected through a non-return valve to the system on the return side of the domestic hot water cylinder or radiators. (Refer Fig. 5).
    - (b) where access to a make-up vessel would be difficult, by pre-pressurisation of the system (Refer Section 6 – Filling).
    - (c) The maximum cold water capacity of the system should not exceed 190 litres if not pre-pressurized. However, if the system is to be pre-pressurized the efficiency of the expansion vessel will be reduced and a larger vessel (or smaller system volume) may be necessary. If the capacity of the vessel is not considered sufficient for this, or any other reason, an additional vessel should be installed on the return to the boiler.

Guidance on vessel sizing is given in Table 7.

**Table 7 – SIZING OF EXPANSION VESSELS**

Safety Valve Setting (bar)	3.0			
Vessel Charge Pressure (bar)	0.5		0.75 (as standard from factory)	
System pre-charge pressure (bar)	None	1.0	None	1.0
System Volume (litres)	Expansion Vessel Volume (litres)			
25	1.2	1.5	1.3	1.5
50	2.4	3.0	2.7	3.0
75	3.6	4.5	4.0	4.5
100	4.8	6.0	5.3	6.0
125	6.0	7.5	6.7	7.5
150	7.2	9.0	8.0	9.0
175	8.4	10.5	9.3	10.5
190	9.1	11.4	10.1	11.4
200	9.6	12.0	10.7	12.0
250	12.0	15.0	13.3	15.0
300	14.4	18.0	16.0	18.0
350	16.8	21.0	18.7	21.0
400	19.2	24.0	21.3	24.0
450	21.6	27.0	24.0	27.0
500	24.0	30.0	26.6	30.0
For system volumes other than those given above then multiply the system volume by the factor across –	0.048	0.060	0.053	0.060

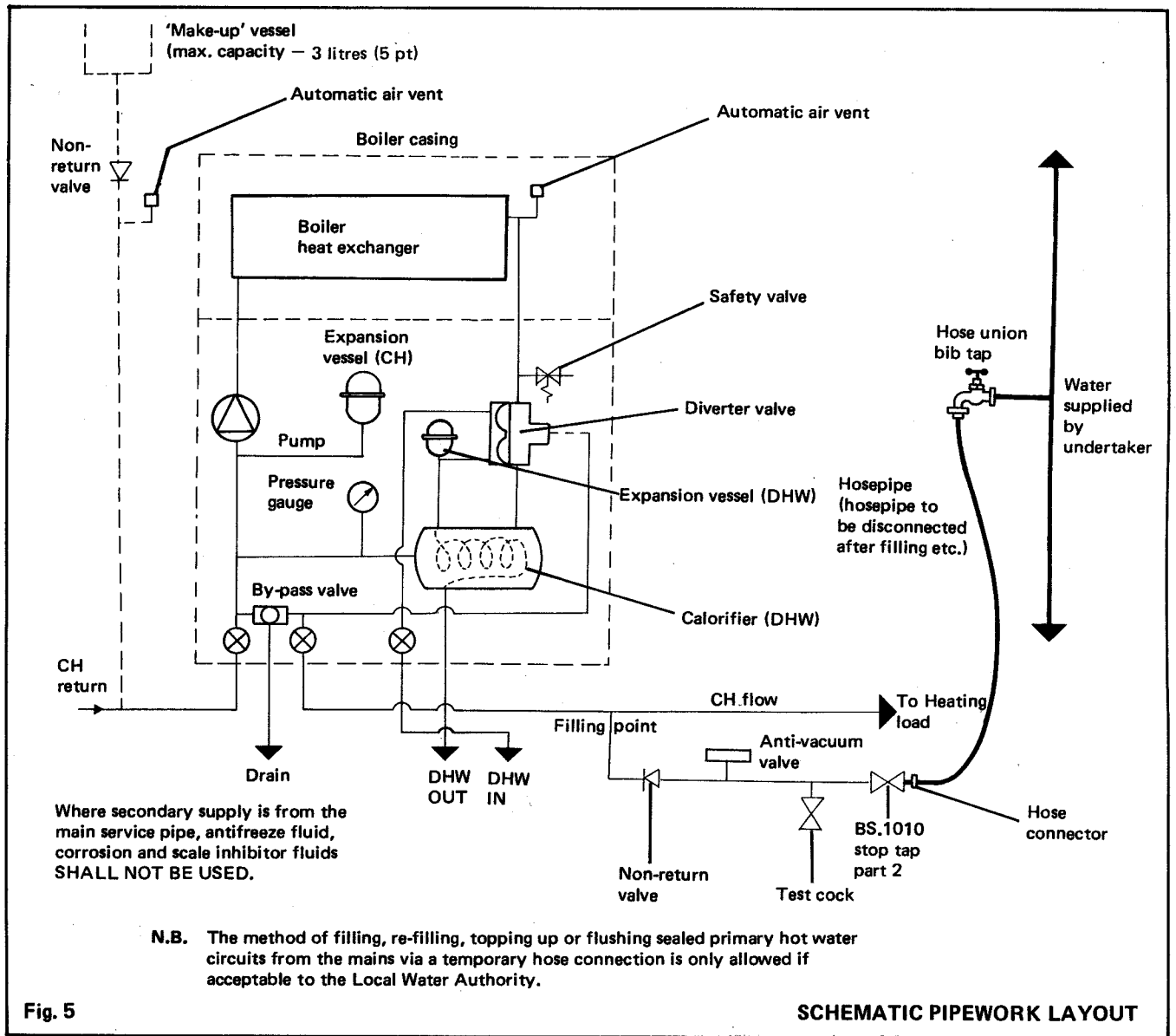

**5. Mains Connection**

There must be no direct connection to the mains water supply or to the water storage tank supplying domestic water, even through a non-return valve, without the approval of the Local Water Authority.

**6. Filling**

The system may be filled by one of the following methods:

- (a) Through a cistern, used for no other purposes, via a ballvalve permanently connected directly to a service pipe and/or cold water distributing pipe. The static head available from the cistern should be adequate to provide the desired initial system design pressure. The cold feed pipe from the cistern should include a non-return valve and a stopvalve with an automatic air vent connected between them, the stopvalve being located between the system and the automatic air vent. The stopvalve may remain open during normal operation of the system if automatic water make-up is required.
- (b) Through a self-contained unit comprising a cistern, pressure booster pump if required, and if necessary, an automatic pressure-reducing valve or flow restrictor. The cistern should be supplied through a temporary connection from a service pipe or cold water distributing pipe. The unit may remain permanently connected to the heating system to provide limited automatic water make-up.

Where the temporary connection is supplied from a service pipe or distributing pipe which also supplies other draw-off points at a lower level a combined check valve and anti-vacuum valve shall be installed upstream of the draw-off point.

- (c) Through a temporary hose connection from a draw-off tap supplied from a service pipe under mains pressure. Where the mains pressure is excessive, a pressure-reducing valve shall be used to facilitate filling. The following fittings shall form a permanent part of the system and shall be fitted in the order stated.

- a stopvalve complying with the requirements of BS.1010:Part 2 (the hose from the draw-off tap shall be connected to this fitting),
- a test cock.
- an anti-vacuum valve of an accepted type.
- a non-return valve of an accepted type.

- (i) Thoroughly flush out the whole of the system with cold water.
- (ii) Fill and vent the system until the pressure gauge registers 1.5 bar (21.75 psi) and examine for leaks.
- (iii) Check the operation of the safety valve by manually raising the water pressure until the valve lifts. This should occur within  $\pm 0.3$  bar ( $\pm 4.3$  psi) of the pre-set lift pressure.
- (iv) Release water from the system until minimum system design pressure is reached, 1.0 bar (14.5 psi) if the system is to be pre-pressurised.

## 7. By-pass

The boiler is fitted with an automatic By-pass valve. Therefore no external system by-pass is required.

## 8. Thermostatic Radiator Valves

Stelrad Group Ltd. support the recommendations made by leading manufacturers of domestic heating controls that; 'heating systems utilising full thermostatic radiator valve control of temperature in individual rooms should also be fitted with a room thermostat- controlling the temperature in a space served by radiator(s) not fitted with such a valve'. Such an arrangement will provide for a potentially more efficient control of the environment and will also avoid the continuous running of the circulation pump during programmed heating 'On' periods- thus saving electrical energy. Therefore it is strongly recommended that when thermostatic radiator valves are used the space heating temperature control over a living/dining area or hallway having a heating requirement of at least 2kW (7,000 Btu/h) is achieved using a room thermostat whilst other rooms are individually controlled by thermostatic radiator valves. If a room thermostat is not fitted, as described above, it is recommended that the system includes one uncontrolled radiator having a minimum heat loss of 1.5kW (5,000 Btu/h) under design conditions.

## 9. Open Water Systems

The IDEAL SPRINT RS.75 is designed for use with sealed systems, but may be connected to open water systems if required. Further details can be obtained from Stelrad Group Ltd.

## GUIDE TO D.H.W. REQUIREMENTS

1. The Ideal Sprint is suitable for connection to most types of washing machines and dishwashing appliances.
2. When connecting to showers,
  - (a) The cold inlet to the boiler must be fitted with an approved anti-vacuum or syphon non-return valve.

- (b) The cold water supply to the shower must have a water governor to equalise the pressure to that of the hot water supply from the boiler.

## FITTING THE AIR/FLUE DUCT ASSEMBLY AND TERMINAL GRILLE – Fig. 6

Separate the terminal grille (E) from the air duct (C) by removing the two screws (F).

Apply a 25mm (1in) wide coating of the sealing compound, packed with the terminal grille, to the ends of the air inlet/ flue outlet ducts as follows:

- to the INNER surface of the boiler air duct (A),
- to the OUTER surface of the terminal air duct (C),
- to the OUTER surface of the boiler flue duct (B),
- to the INNER surface of the terminal flue duct (D).

From OUTSIDE the building, pass the terminal air duct (C) through the opening and slide it into the boiler air duct, – ensuring that duct (C) slides into the air duct (A).

When correctly inserted, push the terminal air duct (C) fully in, until the fixing brackets (G) contact the wall face. Make good between wall and duct OUTSIDE the building.

Pass the terminal flue duct (D) through the opening and slide it into the boiler flue outlet (B) ensuring that duct (D) slides over duct (B). When correctly entered, push the flue terminal assembly fully in and fasten the terminal grille (E) to the bracket (G) with the two screws (F).

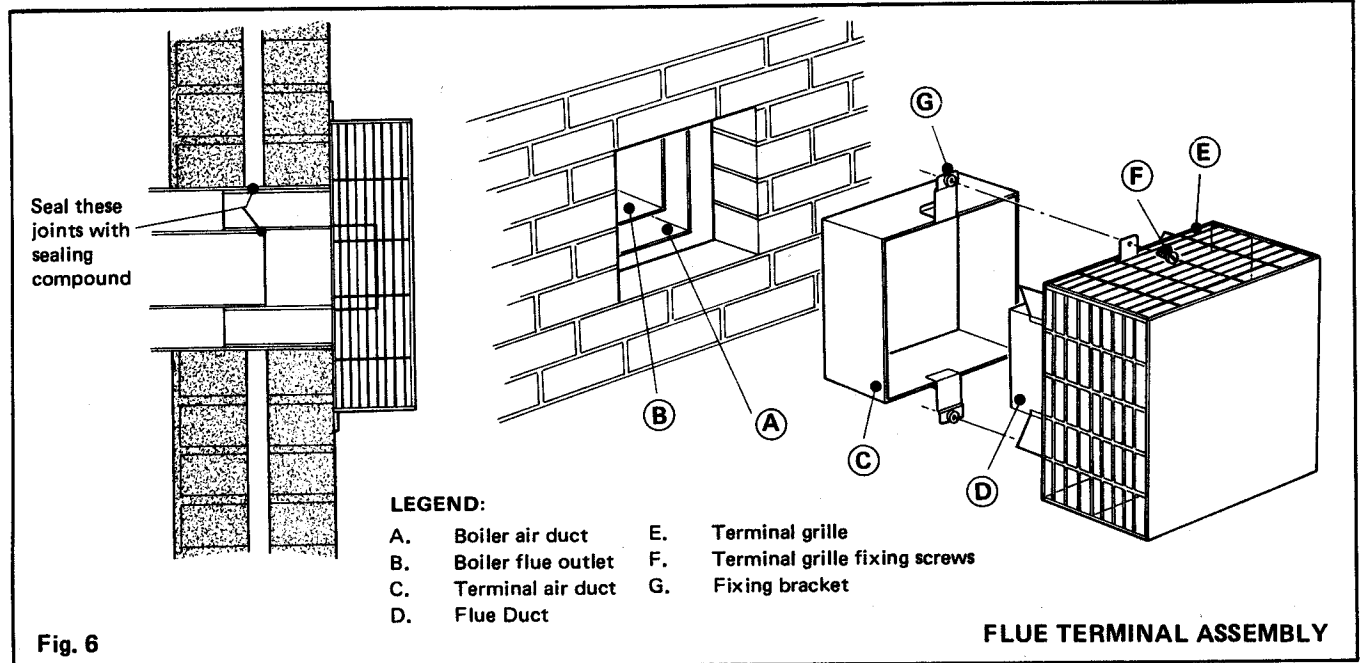

## GAS CONNECTIONS

A minimum gas pressure of 20 mbar (8in.w.g.) MUST be available at the boiler inlet.

Extend a gas supply pipe NOT LESS THAN 15mm O.D. to the boiler and connect to the gas service cock – situated at the bottom, right hand side of the controls compartment. Connection must be made from below the boiler.

## ELECTRICAL CONNECTIONS

**WARNING: The appliance MUST be efficiently earthed.**

A mains supply of 220/240 Volt, 50 Hz, A.C., Single Phase, is required.

ALL external controls and external wiring MUST be suitable for mains voltage.

Wiring should be in three-core, PVC insulated cable, NOT LESS than 24/0.2mm.

Wiring external to the boiler MUST be in accordance with the I.E.E. Wiring Regulations and any Local Regulations which apply.

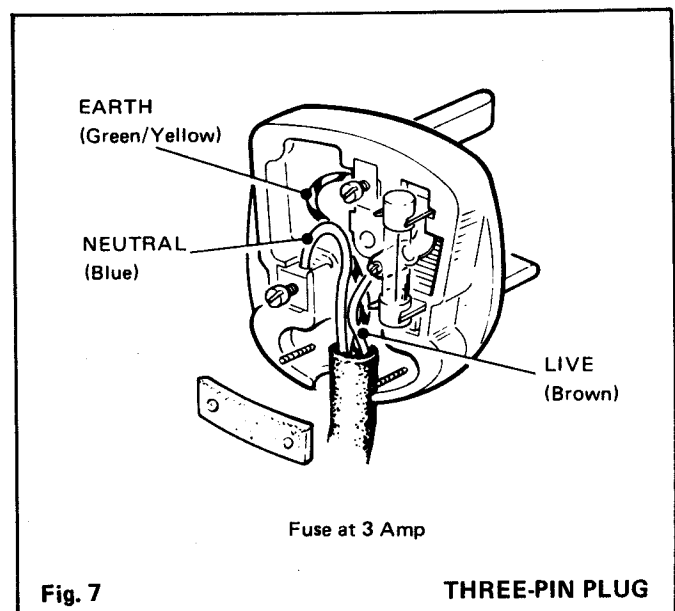

The supply connection may be made via a removable plug to a shuttered socket-outlet and, should such a plug be used for connection to the mains, it MUST be of 3-pin type, wired as shown in Fig. 7, fused at 3 Amp, and complying with the requirements of BS.1363.

Alternatively a fused, double pole switch, having a 3mm (1/8in) contact separation in both poles and serving, only, the boiler may be used.

### INTERNAL WIRING

The internal wiring of the control box is shown in Figs. 8 and 9.

A wiring diagram is also included on the Lighting instruction label affixed to the inside of the controls compartment lift-off cover.

1. Release the captive screw, located at the RH side of the control panel and swing open the panel – hingeing from the left.
2. Lift off the controls inner cover by removing the relevant three screws and paint cutting washers.
3. Pass the mains lead into the bottom RH side of the controls compartment via the grommetted hole and route along the inside front edge of the bottom panel. Secure with the clips provided.
4. Wire into the supply terminals marked L, N and  $\perp$  – secure with the cable clamp .

**Note:** The mains lead connection MUST be made in such a way that, should the lead slip from the anchorage, the current carrying conductors become taut before the earthing conductor.

### EXTERNAL CONTROLS

External wiring MUST be in accordance with the I.E.E. Wiring Regulations.

Difficulty in wiring should not arise, providing the following directions are observed:

1. **Room thermostat** – Remove the link between terminals L1 and L2 and wire in the room thermostat – Refer Fig. 10 (C).
2. Controls that over-ride an ON/OFF control, e.g. a frost thermostat MUST be wired into the mains in parallel with the controls to be over-ridden. Wire the frost thermostat into terminals L<sup>0</sup> and L<sup>2</sup> – refer Fig. 10 (A).
3. **Time Switch**

- (a) **EXTERNAL:** Wire the time switch into terminals L<sup>0</sup>, L<sup>1</sup> and L<sup>2</sup> – refer Fig. 10 (b) or Fig. 10 (d) (including room thermostat).

**Note:** The time switch must have isolated contacts.

- (b) **OPTIONAL PROGRAMMER KIT**  
Refer to the IDEAL SPRINT Programmer Kit Installation Instructions.

Secure all leads with the cable clamp provided.

### COMMISSIONING AND TESTING

#### Electrical Installation:

Checks to ensure electrical safety should be carried out by a competent person.

ALWAYS carry out the Preliminary Electrical System Checks as detailed in the Instructions for the British Gas Multimeter. Refit the controls inner cover.

#### Gas Installation:

The whole of the gas installation, including the meter, should be inspected and tested for soundness, and purged in accordance with the recommendations of CP.331:3.

Purging air from the gas installation may be expedited by loosening the union on the gas service cock and purging until gas is smelled.

Retighten the union and check for gas soundness.

#### WARNING:

Whilst effecting the required gas soundness test and purging air from the gas installation, open all windows and doors, extinguish naked lights and DO NOT SMOKE.

#### INITIAL LIGHTING – Refer Fig. 12

1. Check that the gas service cock is ON and that the 'HEATING' and 'WATER' switches (V), (Y) respectively are OFF.
2. Slacken the screw in the burner pressure test nipple (T) and connect a gas pressure gauge via a flexible tube.
3. Turn the gas control knob (P) CLOCKWISE until resistance is felt and then release it.
4. Push in and retain fully depressed the gas control knob (P), press and release the piezo ignition button (K) repeatedly until the pilot lights.
5. Hold the gas control knob depressed for 15 seconds after the pilot burner has ignited.
6. If the pilot fails to remain alight at this stage, repeat the procedure detailed above but wait longer than 15 seconds before releasing the gas control knob (P).
7. Check the appearance of the pilot flame to ensure that it envelops the tip of the thermocouple, and is approximately 25mm (1in) long.  
The pilot flame is factory set and no adjustment should be necessary.
8. Switch the electricity supply ON, and check that all external controls are calling for heat.  
The 'MAINS ON' neon (B) will glow.

#### HOT WATER ONLY

1. Set the 'WATER' switch to ON and the 'HEATING' switch to OFF. The 'WATER' neon (K) will glow and will continue to do so as long as the 'WATER' switch is ON.
2. Fully open a DHW tap.  
Check that the pump starts and that the burner cross-lights smoothly.
3. Test for gas soundness around the boiler gas components using leak detection fluid.
4. Turn off the DHW tap, and fit the boiler casing as follows:

**Note:** Before fitting the casing remove the retaining tape and polythene bag from the fascia and refit the fascia if required.

Lift the boiler casing up to the boiler assembly and secure with the three fixing screws.

The casing MUST seat correctly and compress the sealing strip to make an air-tight joint.

If side clearance is limited this may be checked by ensuring that the top and bottom edges of the casing are correctly located.

5. Fully open all DHW taps, to ensure that the boiler fires at maximum rate, and operate the boiler for ten minutes to stabilise the burner temperature.  
The burner pressure is pre-set to maximum at the factory and should be 14.1 mbar (5.7in.w.g.)  $\pm 0.5$  mbar (0.2in.w.g.).
6. With the boiler firing as above pull one of the grey electrical leads off the Modureg solenoid, Fig. 9 on the gas control valve. The burner pressure should reduce to the minimum setting which is pre-set in the factory and should be 2.5 mbar (1.0in.w.g.)  $\pm 0.5$  mbar (0.2in.w.g.).  
**Note:** If either of the pressures is incorrect contact Stelrad Group Ltd.
7. Re-connect the grey electrical lead to the Modureg solenoid to return the burner pressure to the maximum setting.

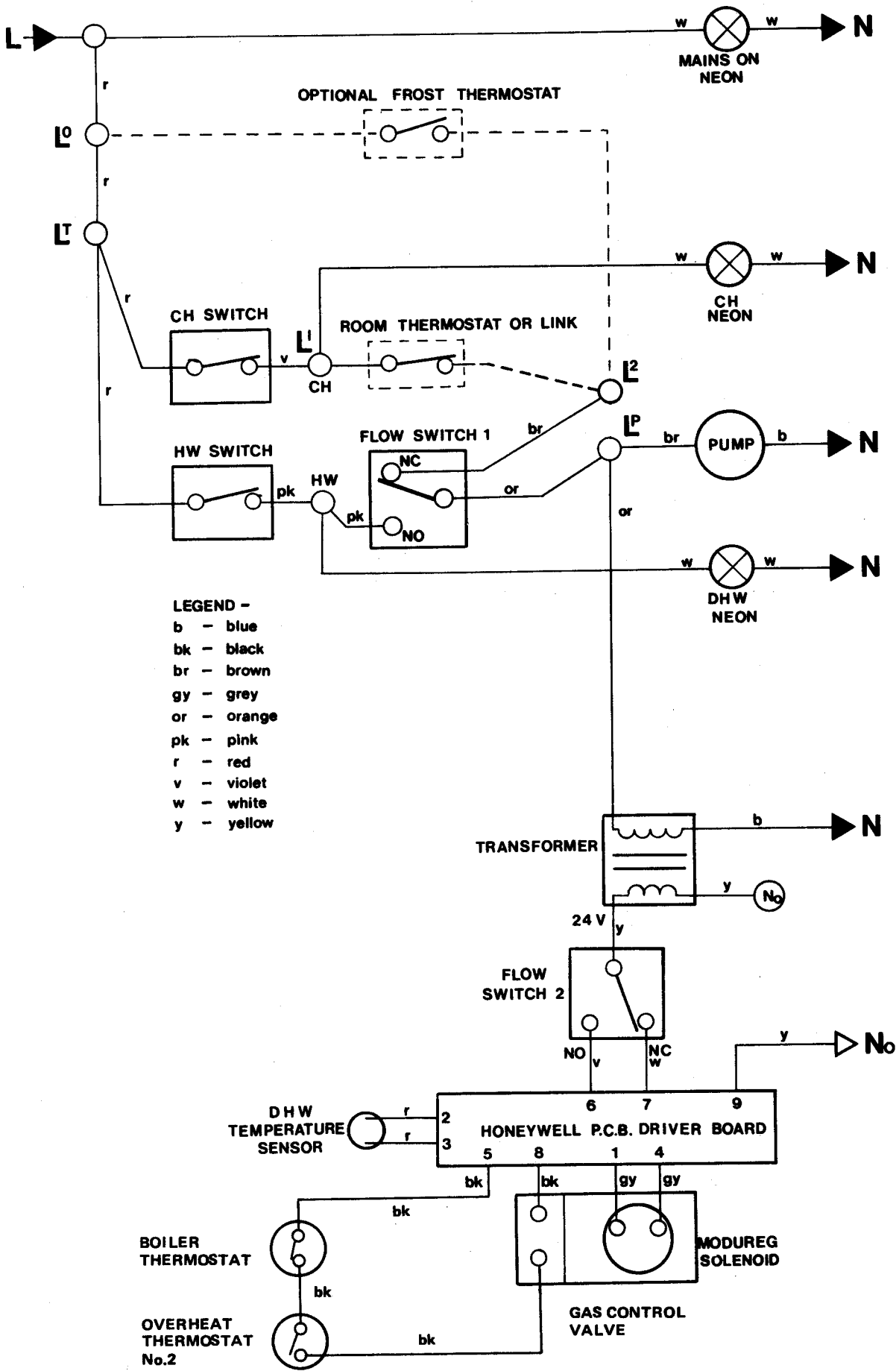
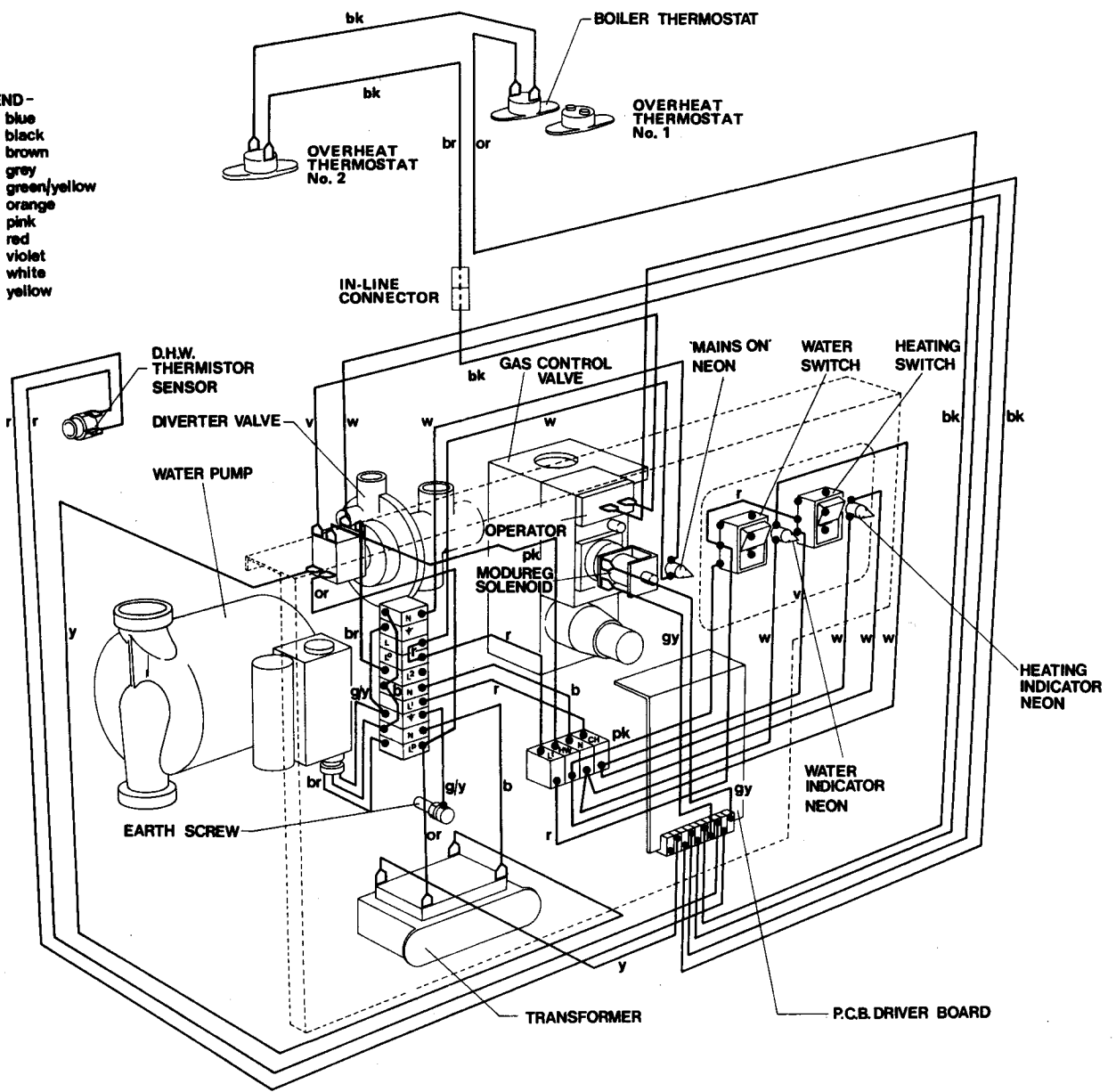

Fig. 8

FLOW WIRING DIAGRAM

**LEGEND -**  
 b - blue  
 bk - black  
 br - brown  
 gy - grey  
 g/y - green/yellow  
 or - orange  
 pk - pink  
 r - red  
 v - violet  
 w - white  
 y - yellow



8. Reduce the DHW draw-off rate to the minimum required to keep the boiler firing and check that the burner pressure decreases in response to DHW temperature rise.
9. Close the DHW tap and check that the main burner extinguishes and the pump stops.

turn the 'HEATING' switch OFF and then ON again. Check the setting pressure and re-adjust if it has deviated more than 0.5 mbar (0.2 in.w.g.).

- (d) Make final adjustment as (c) above.
- (e) Swing the cover (S) back into position and secure.

4. Set the Indicator on the Data Plate, located at the front RH side of the bottom panel, to the appropriate burner setting pressure.

### HEATING AND HOT WATER

1. Set the 'WATER' switch to ON and the 'HEATING' switch to ON.  
The 'HEATING' neon (W) and 'WATER' neon (X) will glow.
2. Check that the pump starts and that the burner cross-ignites smoothly from the pilot flame.
3. The boiler is pre-set at the factory to its lowest nominal rating, but can be range rated to suit the system design requirements. — Refer Table 2 on Page 2. If the burner pressure setting requires adjustment proceed as follows:—
  - (a) Remove the securing screw of the cover (S) on the control panel and swing the cover aside to expose the CH setting pressure adjuster (D).
  - (b) Turn the adjusting screw (D) ANTICLOCKWISE to INCREASE the pressure or CLOCKWISE to DECREASE the pressure.
  - (c) To ensure that the setting pressure is maintained

### DHW FLOW-RATE SETTING

1. Set the 'WATER' switch to ON and the 'HEATING' switch to OFF.
2. Fully open all DHW taps and ensure that water flows freely from them.
3. Close all taps except the furthest one from the boiler and check that the boiler is firing at maximum rate.
4. Adjust the DHW flowrate by turning the throttle screw (40) on the diverter valve (22) — Refer Fig. 3 on Page 7 until a DHW flowrate of 9 l/min is measured at the tap.
5. Turn off the DHW tap.

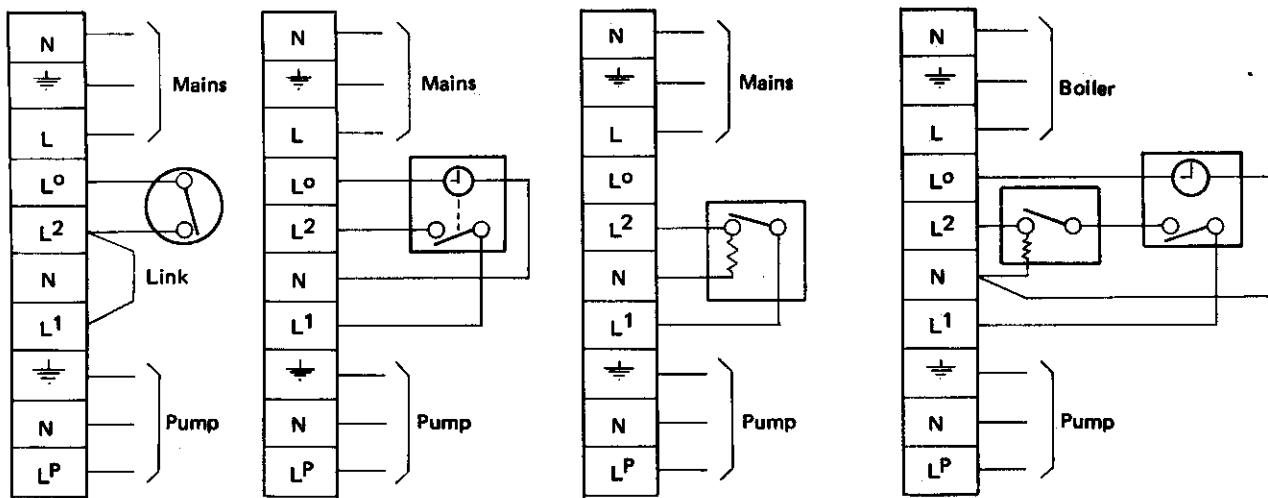

(a) FROST THERMOSTAT

(b) TYPICAL CLOCK (N.B. isolated contacts)

(c) ROOM THERMOSTAT

(d) ROOM THERMOSTAT AND CLOCK

A frost thermostat may be wired, as shown above, to any of the systems illustrated.

In the event of the premises being empty for several days in frosty weather, then the pilot and mains supply MUST be left 'On' with the boiler switched 'Off' at the CH/HW switches.

If a clock other than the 'Stalrad Programmer Kit' is to be fitted then a time switch with isolated contacts should be chosen — wired as shown above. Full instructions for the 'Stalrad Programmer Kit' are provided with the kit.

Fig. 10

## SYSTEMS WIRING DIAGRAMS

6. Remove the pressure gauge and tube and re-tighten the sealing screw in the pressure test nipple, ensuring that a gas-tight seal is made.

### GENERAL CHECKS

Make the following checks for correct operation.

#### 1. HOT WATER MODE

- (a) Set the 'WATER' switch to ON and the 'HEATING' switch to OFF.  
Check that the 'WATER' indicator neon glows.
- (b) Fully open a DHW tap and check that the pump starts and the main burner lights in response.
- (c) Close the DHW tap and check that the burner extinguishes and the pump stops.  
The 'WATER' indicator neon should remain illuminated.

#### 2. HEATING AND HOT WATER MODE

- (a) Set the 'WATER' and 'HEATING' switches to ON.  
Check that the main burner lights and both 'HEATING' and 'WATER' indicator neons glow in response.

**Note:** If a programmer is fitted, the 'HEATING' neon will only glow during 'ON' periods.

- (b) Fully open a DHW tap and check that hot water is delivered.
- (c) Close the DHW tap, set the 'HEATING' switch to OFF and check that the main burner extinguishes and the pump stops.

#### 3. FLAME FAILURE DEVICE

Check the operation of the flame failure device in the gas control valve as follows:—

- (a) Extinguish the pilot flame by closing the gas

service cock (N) and note the time taken for the flame failure device to shut down — identified by a click within the gas control valve. This MUST NOT be longer than 60 seconds.

- (b) Open the gas service cock and re-light the pilot.
- (c) Set the 'HEATING' switch to ON and the main burner should light.
- (d) Turn the gas control knob (P) CLOCKWISE until resistance is felt and then release it. The main burner and pilot flames should shut down immediately.

**Note:** A latch in the gas control valve provides a safety delay period of approximately 30 seconds before the boiler can be re-lit.

#### 4. WATER CIRCULATION SYSTEM

- (a) With the system cold check that the initial pressure is correct to the system design requirements. For pre-pressurised systems this should be 1.0 bar (14.5 psi).
- (b) Set the RED fill-pressure indicator on the pressure gauge (C) — Refer Fig. 12 — to the initial system pressure.
- (c) With the system hot examine all water connections for soundness. The system pressure will increase with temperature rise but should not exceed 2.5 bar (36.3 psi).
- (d) With the system still hot turn off the gas, water and electricity supplies to the boiler and drain down in order to complete the flushing process.
- (e) Re-fill and vent the system as described in 'Guide to System Requirements', clear all air locks and again check for water soundness.
- (f) Re-set the system initial pressure to the design requirement.

**Finally:—**

1. Swing the control panel back into its working position and secure.
2. Re-fit the controls compartment front cover and set the controls to the User's requirements.

**Note:** If an optional Programmer Kit is fitted, refer to the Programmer Kit Installation and User's Instructions.

**WARNING:**

The boiler **MUST NOT** be operated with the casing removed.

**HANDING OVER**

After completion of installation and commissioning the system, the Installer should hand over to the Householder by the following actions:

1. Hand the User's Instructions to the Householder and explain his/her responsibilities under the Gas Safety, (Installation and Use) Regulations 1984.
2. Draw attention to the Lighting Instruction label affixed to the inside of the control compartment front cover.
3. Explain and demonstrate the lighting and shutting down procedures.

4. The operation of the boiler and the use and adjustment of ALL system controls should be fully explained to the Householder, to ensure the greatest possible fuel economy, consistent with household requirements of both heating and hot water consumption.

Advise the User of the precautions necessary to prevent damage to the system, and to the building, in the event of the system remaining in-operative during frost conditions.

5. Explain the function and the use of the boiler 'HEATING' and 'WATER' switches.
6. Explain the function of the boiler over-heat thermostat.

Emphasise that if cut-out occurs, the boiler should be turned off and the local Heating Installer consulted.

7. Explain and demonstrate the function of time and temperature controls, radiator valves, etc. for the economic use of the system.
8. If an optional Programmer Kit is fitted, then draw attention to the Programmer Kit User's Instructions and hand them to the Householder.
9. Stress the importance of regular servicing by the Local Gas Region or by a qualified Heating Engineer and that a comprehensive service should be carried out **AT LEAST ONCE A YEAR.**

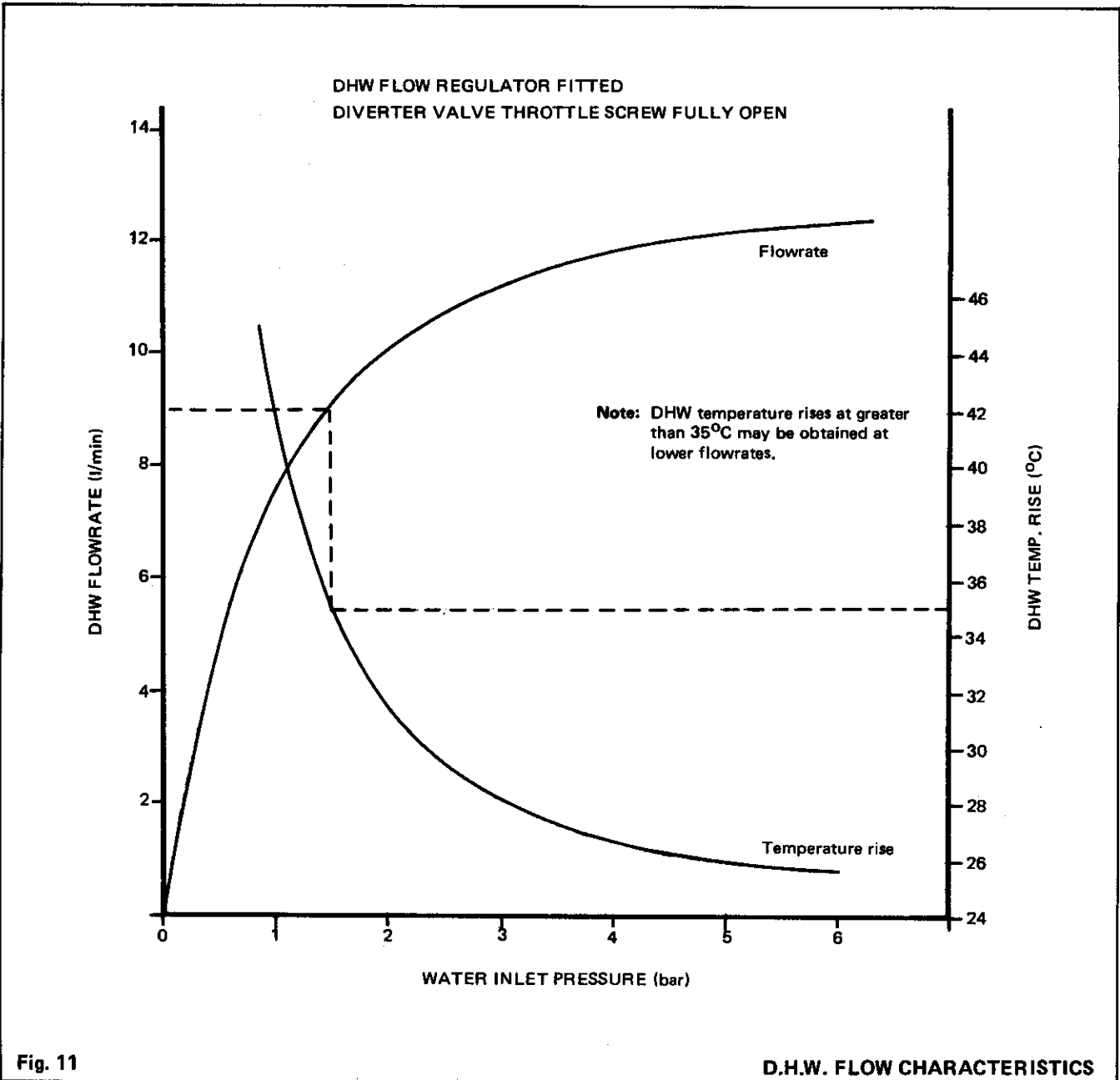



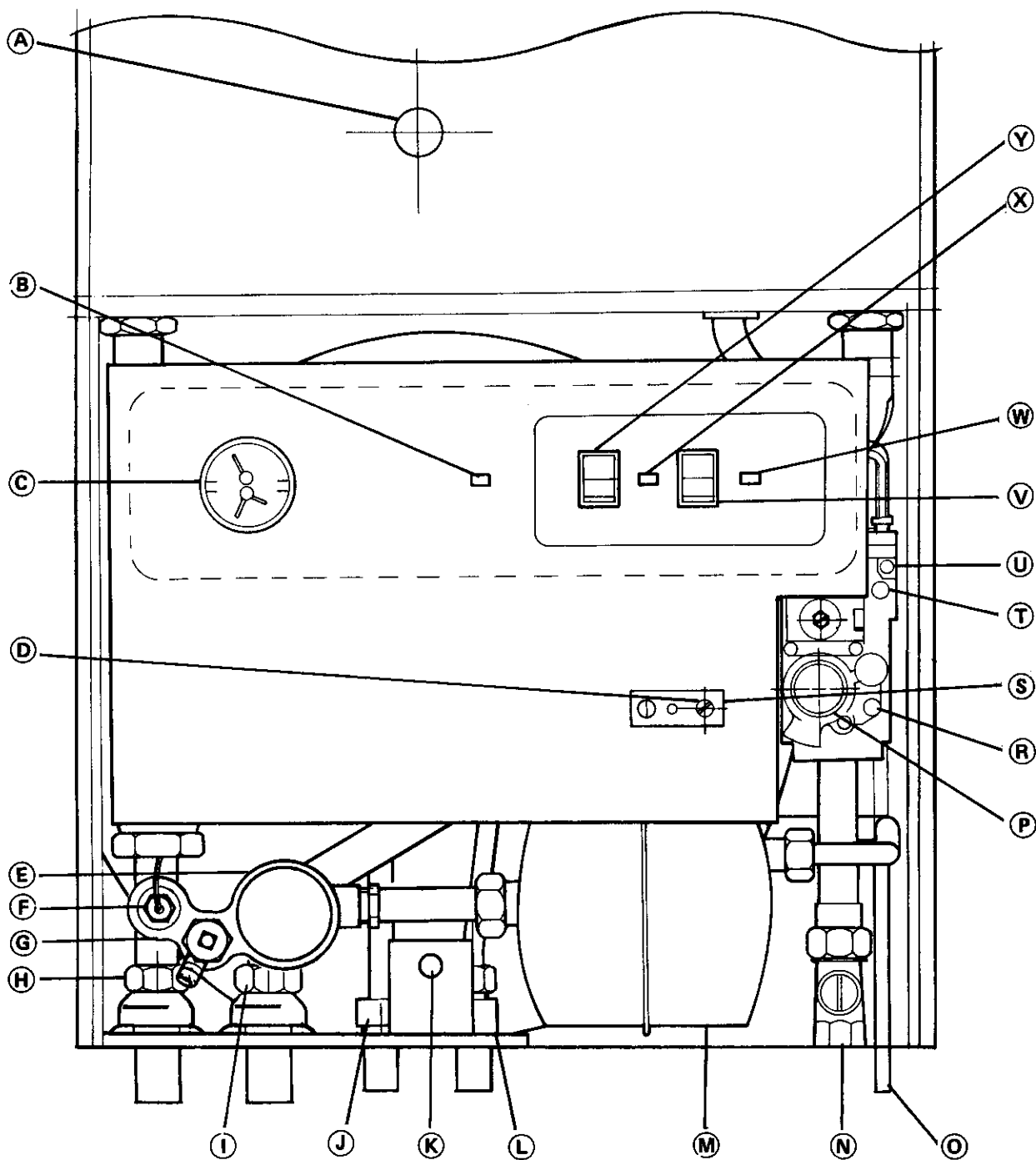

**LEGEND:**

- |    |                              |    |  |
|----|------------------------------|----|--|
| A. | Sight-glass                  | N. | Gas service cock                         |
| B. | 'Mains On' indicator neon    | O. | Safety valve drain pipe                  |
| C. | Pressure/temperature gauge   | P. | Gas valve control knob                   |
| D. | CH setting pressure adjuster | R. | Inlet pressure test nipple               |
| E. | By-pass valve                | S. | CH setting pressure adjuster screw cover |
| F. | Pressure gauge connection    | T. | Burner pressure test nipple              |
| G. | Drain cock                   | U. | Pilot pressure adjuster                  |
| H. | CH return isolating valve    | V. | 'HEATING' switch                         |
| I. | CH flow isolating valve      | W. | 'HEATING' indicator neon                 |
| J. | DHW outlet flow regulator    | X. | 'WATER' indicator neon                   |
| K. | Piezo unit ignition button   | Y. | 'WATER' switch                           |
| L. | DHW inlet isolating valve    |    |  |
| M. | DHW calorifier               |    |  |

# SERVICING

## WARNING:

**ALWAYS turn OFF the gas supply at the gas service cock and switch OFF and DISCONNECT the electricity supply to the appliance BEFORE SERVICING.**

## IMPORTANT

**AFTER COMPLETING ANY SERVICING OR EXCHANGE OF GAS CARRYING COMPONENTS ALWAYS TEST FOR GAS SOUNDNESS.**

## TO REMOVE THE BOILER CASING

Refer Fig. 1

1. Lift off the controls compartment front cover. Release the two captive screws at the top of the casing, and the single captive screw within the controls compartment and lift the casing off the boiler, taking care not to damage the glass fascia panel (if fitted).

## TO REMOVE THE MAIN BURNER AND CONTROLS ASSEMBLY – Refer Fig. 3

1. Release the captive screw at the RH side of the control panel and swing the panel open – hingeing from the left.
2. Disconnect the four electrical leads from the gas control valve – the grey wires should be connected to the green Modureg solenoid on the gas control valve – refer Fig. 9.
3. Disconnect the spark lead from the piezo unit body.
4. Undo the union nut on the gas service cock.
5. Undo the two screws securing the gas supply pipe sealing clamp to the backplate and remove the clamp and front rubber block.

6. Support the assembly and undo the wing nut securing the burner front support bracket to the heat exchanger skirt.
7. Draw the complete assembly forward and disconnect the thermocouple and the two interrupter leads from the gas control valve.
8. Remove the assembly to a convenient working surface for attention.
9. Brush off any deposits that may have fallen on to the burner head, ensuring the flame ports are un-obstructed, and remove any debris that may have collected.

**Note:** Brushes with metallic bristles must NOT be used.

10. Remove the main burner injector; ensure there is no blockage or damage.
11. Replace the injector – use an approved jointing compound, sparingly.
12. Inspect the pilot burner, thermocouple and spark electrode; ensure they are clean and in good condition. In particular, check that:
  - (a) The pilot burner injector is not blocked or damaged.
  - (b) The pilot burner is clean and unobstructed.
  - (c) The spark electrode is clean and undamaged.
  - (d) The spark lead is in good condition and securely connected.
  - (e) The spark gap is correct – Refer Fig. 13.
  - (f) The thermocouple tip is not burned or cracked.
  - (g) The position of the thermocouple relative to the pilot burner and main burner is correct – Refer Fig. 13.
  - (h) The thermocouple terminal at the gas valve is clean.

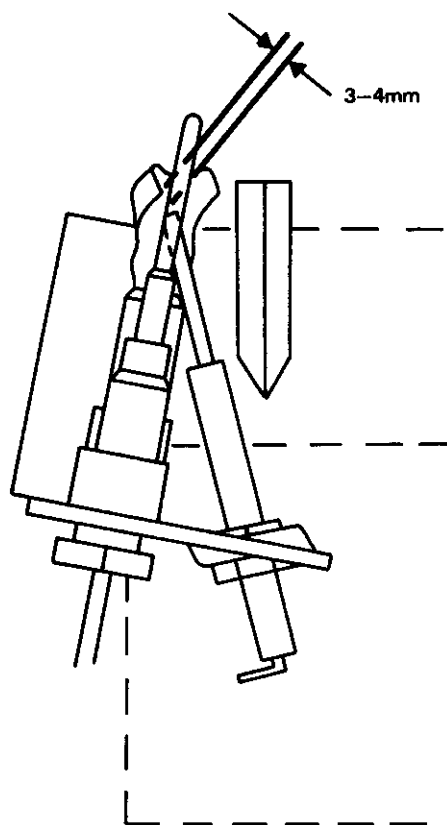

Fig. 13

PILOT AND ELECTRODE POSITION

## TO CLEAN THE FLUEWAYS

With the main burner and controls assembly removed as previously described:

1. Remove the two screws at the top rear of the flue collector hood.
2. Slacken the four wing nuts on top of the collector hood, disengage the tie-rods – NOTING THEIR POSITION – and remove the hood.
3. Remove all loose deposits from the heat exchanger finned block, brushing from above and below, and from the copper skirt, using a suitable brush – and /or clearing rod.
4. Refit the flue collector hood in reverse order – replacing any damaged or deteriorating sealing gaskets.
5. Refit the burner and controls assembly in reverse order.
6. Reconnect the gas and electrical supplies.
7. Ensure the sight glass in the boiler casing is clean and undamaged.
8. Swing the control panel closed and secure .
9. Refit the boiler casing.
10. Refit the controls compartment front cover.

## PILOT BURNER

Light the pilot and check that the pilot flame envelops the tip of the thermocouple, and is approximately 25 mm (1 in) long.

The pilot adjuster screw is factory set to maximum and no further adjustment should be necessary.

However, if the pilot flame appears small, check the adjustment of the pilot pressure adjuster screw – Fig. 11, as follows:

- (a) Turn the gas control knob (P), CLOCKWISE, until resistance is felt and then release it.
- (b) Turn the pilot pressure adjuster screw (u) CLOCKWISE until fully CLOSED.
- (c) Turn the pilot pressure adjuster screw ANTI-CLOCKWISE four full turns to give maximum setting.
- (d) Relight the pilot in accordance with the Lighting Instructions.

**Note:** A large capacity pilot filter is incorporated in the gas control valve, and, requires no maintenance.

## ADJUSTMENT OF GAS PRESSURE – Refer Fig. 12

After each occasion of servicing, reference should be made to Table 2 which quotes details of the rated output, with the related burner setting pressure and the heat input, for both Central Heating and Domestic Hot Water modes.

Any required adjustment should be made by using the pressure adjustment screw (D).

Refer to 'Initial Lighting' on Page 12.

## REPLACEMENT OF COMPONENTS

### WARNING:

**ALWAYS turn OFF the gas supply at the gas service cock and switch OFF and DISCONNECT the electricity supply BEFORE WORKING ON THE APPLIANCE.**

**Note:** To replace the following components, it will be necessary to remove the boiler casing, as previously described.

### Sight Glass

1. Remove the fascia panel, if fitted, from the casing by sliding it upwards.
2. Unfasten the two nuts and washers holding the sight-glass assembly to the casing front panel.
3. When fitting the new assembly, make certain the parts are in the correct order, i.e. gasket, glass, gasket and frame.

**Note:** The frame MUST have the return edge at the bottom.

4. Retighten the two nuts to ensure an airtight seal. Do NOT overtighten.
5. Refit the fascia panel.

### Boiler Control Thermostat (Central Heating)

The control thermostat has push-on connections.

1. Loosen the two screws securing the thermostat to the mounting plate and disengage the thermostat.

**Note:** If access is difficult then remove the collector hood – as previously described.

2. Pull the two electrical connections off the thermostat.
3. Fit the new thermostat and re-assemble in reverse order.

### Boiler Overheat Thermostat No. 1 – Refer Fig. 3

The overheat thermostat has soldered on connections.

1. Remove the main burner and controls assembly as previously described.
2. Release the strain relief bush from the bottom panel and withdraw the interrupter leads.
3. Release the overheat lead from the clips on the back plate.
4. Remove the two screws securing the thermostat to the mounting plate and remove the thermostat .
5. Fit the new assembly in reverse order, ensuring that the strain relief bush is fitted correctly.

### Boiler Overheat Thermostat No. 2 – Refer Fig. 3

1. Remove the two screws securing the thermostat to the mounting plate.
2. Pull the two electrical leads off the thermostat.
3. Fit the new thermostat and re-assemble in reverse order.

### Piezo Unit

1. Disconnect the spark lead from the piezo unit body.
2. Remove the two screws securing the piezo unit bracket to the casing bottom panel and withdraw the bracket complete with piezo unit.
3. Remove the back nut and withdraw the unit from the bracket – bending the connector tab to clear the bracket.
4. Fit the new unit and re-assemble in reverse order. Bend the connector tab at right angles to the piezo unit body after fitting to the mounting bracket. Check that the new unit functions correctly.

### Pilot Burner Assembly

1. Remove the burner and controls assembly as previously described.
2. Undo the thermocouple and pilot pipe connections at the pilot burner and the gas control valve and pull clear of the pilot burner. Do not lose the pilot injector which is a push fit in the pilot pipe connection to the pilot burner.
3. Disconnect the spark lead from the base of the electrode.
4. Undo the two screws securing the pilot burner to the main burner and remove, complete with the pilot shield.
5. Undo the screw securing the shield to the pilot burner and remove the shield.
6. Remove the spark electrode locking nut and withdraw the electrode.
7. Transfer the electrode and shield to the new pilot burner ensuring that the spark gap is correct. Refer Fig. 13.
8. Fit the new pilot burner and ensure that the injector is in position when refitting the pilot pipe. Re-assemble in reverse order.

### Spark Electrode

1. Remove the pilot burner assembly as previously described.
2. Remove the electrode locking nut and withdraw the electrode.
3. Fit the new electrode and re-assemble in reverse order.

### Spark Lead

1. Swing open the control panel as previously described.
2. Undo the two screws securing the gas supply pipe sealing clamp to the backplate and remove the clamp and front rubber block.
3. Disconnect the spark lead from the base of the electrode and from the piezo unit body.
4. Remove the clips securing the lead to the pilot supply pipe and withdraw the lead.
5. Fit the new lead and re-assemble in reverse order.

### Thermocouple

1. Remove the burner and controls assembly as previously described.
2. Remove the clips securing the thermocouple to the pilot supply pipe.
3. Undo the thermocouple connection at the pilot burner and withdraw the thermocouple.
4. Fit the new thermocouple. Avoid sharp bends in the thermocouple and ensure that it follows the same route as previously.
5. Re-assemble in reverse order.

### Main Burner – Refer Fig. 3

1. Remove the burner and controls assembly as previously described.
2. Remove the pilot burner assembly as previously described.
3. Remove the two nuts securing the burner to the manifold and withdraw the burner.
4. Remove the burner end bracket and transfer to the new burner.
5. Fit the new burner and re-assemble in reverse order.

### Gas Control Valve

1. Remove the burner and controls assembly as previously described.
2. Undo the pilot pipe connection at the gas valve.
3. Undo the four screws securing the gas valve outlet pipe flange and withdraw the valve.  
The sealing 'O' ring should be discarded and a new one fitted.
4. Unscrew the inlet pipe and transfer it to the new valve using a suitable jointing compound.
5. Fit the new gas valve ensuring that:
  - (a) The valve is fitted the right way round; an arrow engraved on the valve, indicates the direction of flow.
  - (b) The sealing 'O' ring, supplied with the valve, is correctly fitted at the outlet flange.
6. Re-assemble in reverse order.

### Modureg Solenoid

1. Pull the two grey leads off the solenoid.
2. Remove the two screws securing the solenoid operator to the gas control valve and lift off the solenoid.
3. Fit the new solenoid in reverse order.

### Casing Seals

1. Remove the old seals from the top and sides of the back plate and, also, from the middle edge of the boiler casing. Scrape off any traces of old adhesive, etc.

2. Peel the backing tape off the new sealing strip; apply to the back and sides of the backplate and, also, to the middle edge of the boiler casing.  
The top strip should overlap the side strips at the top corners. Avoid stretching the sealing and ensure a good bond by pressing down firmly.
3. Re-assemble in reverse order. Ensure that the casing is correctly seated – compressing the sealing strip to make an airtight joint. If the side clearances are limited then this can be checked by ensuring that the top and bottom edges of the casing are correctly located.

### Pipe Sealing Blocks

1. Remove the burner and controls assembly as previously described.
2. Remove the sealing blocks in the pipe clamp and the backplate bracket.
3. Fit the new blocks and re-assemble in reverse order.

### Transformer

1. Swing open the control panel – as previously described.
2. Remove the three screws and paint cutting washers securing the controls inner cover and lift off the cover.
3. Pull the two yellow, low voltage leads off the bottom terminals of the transformer.
4. Disconnect the orange, mains voltage, lead from terminal 'L<sup>S</sup>' and the blue, mains voltage, lead from terminal 'N' on the terminal strip – refer Fig. 9.
5. Withdraw the transformer from the control panel by, first, removing the securing nuts, washers and screws.
6. Fit the new transformer and re-assemble in reverse order. Ensure that all the electrical connections are correctly remade – refer Fig. 9.

### 'HEATING' and 'WATER' Switches

1. Swing open the control panel and remove the inner cover – as previously described.
2. Pull the red lead off the switch bottom terminal and the pink lead (WATER switch) or violet lead (HEATING switch) off the top terminal.
3. Compress the retaining clips and prise the defective switch out, through the front of the control panel.
4. Fit the new switch and re-assemble in reverse order. Ensure that:
  - (a) The switch is the correct way up – the two terminals should be positioned toward the bottom of the control panel.
  - (b) All electrical connections are correctly re-made – refer Fig. 9.
  - (c) The indicator neons have not been displaced during the switch replacement.

### Indicator Neons

1. Swing open the control panel and remove the inner cover – as previously described.
2. Disengage the neon from within the lens, contained in the control panel.
3. Disconnect the leads from the terminals marked 'N' and 'CH' ('HEATING' neon), 'HW' (WATER neon) or 'L' ('MAINS ON' neon).
4. Fit the new neon and re-assemble in reverse order. Ensure that all the electrical connections are correctly remade – refer Fig. 9.

### P.C.B. Driver Board

1. Swing open the control panel and remove the inner cover – as previously described.
2. Disengage the board from the four mounting pegs by compressing the pegs with pliers.
3. Unplug the edge connector from the board.
4. Fit the new board and re-assemble in reverse order.

### IMPORTANT:

IN ADDITION TO REMOVING THE BOILER CASING, IN ORDER TO REPLACE THE FOLLOWING COMPONENTS, IT IS ALSO NECESSARY TO DRAIN THE BOILER.

Close the isolating valves (I) and (H) on the central heating flow and return pipes of the boiler. Drain via the drain cock (G) – refer Fig. 12.

There may be some slight water leakage, and gas and electrical components and the floor should be protected with water proof sheets or similar.

To refill the boiler then refer to 'Filling Instructions' on page 10.

### D.H.W. Thermistor Sensor

1. Swing open the control panel – as previously described.
2. Pull the electrical leads off the DHW thermistor sensor, located on the boiler return pipe.
3. Unscrew the sensor from the pipe.
4. Fit the new thermistor sensor and re-assemble in reverse order.

### Pressure/Temperature Gauge

1. Swing open the control panel as previously described.
2. Unclip the temperature sensor from the boiler flow pipe.
3. Undo the SMALL hexagon nut connecting the pressure sensor to the bypass valve block, and withdraw the sensor.
4. Unclip the pressure and temperature sensor capillaries from the back of the control panel.
5. Undo the knurled nut at the back of the gauge and remove the retaining clamp.
6. Withdraw the gauge through the front of the control panel.
7. Fit the new gauge and re-assemble in reverse order. Ensure that:
  - (a) The capillaries are carefully and neatly routed.
  - (b) The gauge is correctly orientated within the control panel.
  - (c) The temperature sensor is correctly positioned – butting the safety valve connecting boss.

### DHW Expansion Vessel

1. Swing open the control panel as previously described.
2. Close the isolating valve (L) on the DHW inlet connection to the boiler – refer Fig. 12
3. Open the lowest DHW draw-off tap.
4. Unscrew the DHW expansion vessel from the pipe – applying an appropriate counterforce in order to prevent damage.
5. Fit the new vessel, using a suitable jointing compound, and re-assemble in reverse order.

### Diverter Valve

1. Close the isolating valve (L) on the DHW inlet connection to the boiler – refer Fig. 12
2. Open the lowest DHW draw-off tap.
3. Swing open the control panel – as previously described.
4. Pull off the clip securing the micro switch assembly to the left hand end of the diverter valve and withdraw the assembly to gain access to the electrical connections.
5. Disconnect the leads, as follows:
  - (a) YELLOW lead from the LH terminal;
  - (b) VIOLET lead from the centre terminal;
  - (c) WHITE lead from the RH terminal;
  - (d) Unplug the three in-line connectors in the, soldered-on PINK, BROWN and ORANGE leads.
6. Undo the five union connections and remove the valve. Discard the old sealing washers.
7. Fit the new valve, complete with the new sealing washers provided, in reverse order. Ensure that all the electrical connections are correctly remade – refer to 'Instruction 5, above.

### DHW Calorifier

1. Close the isolating valve (L) CH on the DHW inlet connection to the boiler – refer Fig. 12.
2. Open the lowest DHW draw-off tap.
3. Swing open the control panel – as previously described.
4. Undo the four union connections and remove the calorifier. Discard the old sealing washers.
5. Fit the new calorifier, complete with the new sealing washers provided, in reverse order.

**Note:** To descale the calorifier;

- (a) Remove the calorifier from the boiler as described above.
- (b) Descale the domestic hot water coil, using a proprietary descaling agent.
- (c) Rinse thoroughly with clean water.
- (d) Re-assemble in reverse order.

### WARNING:

These compounds are highly corrosive and ingestion or contact with skin, eyes and clothing MUST be avoided.

Protective clothing should be worn and the descaling operation conducted out of doors or in a well ventilated area.

### Pump

1. Swing open the control panel – as previously described.
2. Remove the burner and control assembly – as previously described.
3. Unclip the temperature sensor from the boiler flow-pipe.
4. Remove the pump terminal box cover, disconnect the brown lead from the RH terminal and the blue lead from the centre terminal.
5. Pull the leads off the DHW thermistor sensor.
6. Undo the screws securing the control panel top support bracket and swing the bracket aside.
7. Undo the union connecting the pump outlet pipe to the boiler heat exchanger.
8. Slacken the 2.5mm socket screw located on the bypass valve block, below the bottom pump union.
9. Withdraw the pump – complete with inlet and outlet pipes – by rotating it to the left and lifting.
10. Undo the pump union connections. Use the new sealing gaskets provided and transfer the inlet and outlet pipes to the new pump.

11. Re-assemble in reverse order and ensure that:
  - (a) The new sealing washer, provided, is fitted to the outlet pipe connection on the boiler heat exchanger.
  - (b) The electrical connections are correctly re-made – Refer to 'Instruction 3' and the diagram inside of the terminal box cover.
  - (c) The pump selector switch cover is correctly fitted and that the switch is set at position '3'.

### **Safety Valve**

1. Remove the burner and controls assembly as previously described.
2. Unclip the temperature sensor from the boiler flow pipe.
3. Undo the safety valve drain pipe union connection.
4. Unscrew the valve from the boiler flow pipe – applying an appropriate counter-force in order to prevent damage.
5. Unscrew the fitting from the valve outlet and transfer it to the new valve.
6. Fit the new valve using a suitable jointing compound and re-assemble in reverse order.

### **Boiler Heat Exchanger**

1. Remove the boiler control and overheat thermostats as previously described.
2. Unscrew the automatic air vent from the flow header of the heat exchanger.
3. Remove the burner and controls assembly and the flue collector hood, as previously described.
4. Support the heat exchanger and undo the union nuts connecting the flow and return pipes to the inter-panel.

5. Disengage the rear edge of the heat exchanger skirt from the inter-panel and withdraw the heat exchanger.
6. Fit the new heat exchanger and re-assemble in reverse order.

### **CH Expansion Vessel**

In the unlikely event of the failure of the CH expansion vessel it is recommended that a new vessel be fitted – exterior to the boiler. It should be positioned on the return pipe and as close to the boiler as possible. If, however, the vessel must be replaced then the following procedure may be used:

1. Drain down the complete CH system and isolate the DHW circuit from the mains water supply.
2. Remove the main burner and controls assembly – as previously described.
3. Remove the pump – as previously described.
4. Remove the piezo unit – as previously described.
5. Disconnect the safety valve drain pipe – as previously described.
6. Disconnect the electrical leads from the diverter valve – as previously described.
7. Undo the union connecting the boiler flow pipe to the boiler heat exchanger.
8. Undo the pipe connection at the expansion vessel.
9. Disconnect the CH flow pipe, CH return pipe, DHW inlet pipe and DHW outlet pipe from the boiler.
10. Remove the four screws securing the 'by-pass valve block' mounting plate to the bottom panel. Lift the complete pipework assembly out of the controls compartment.
11. Lift out the expansion vessel.
12. Fit the new vessel and re-assemble in reverse order.

**LEGEND:**

- 1. Neon indicators
- 2. Neon indicator lens
- 3. Selector switch (2-off)
- 4. Fascia label
- 5. 12-way connector
- 6. Control panel
- 7. Pressure/temperature gauge
- 8. Insulation pad
- 9. Earth post
- 10. Transformer
- 11. Fastening spigot (4-off)
- 12. Edge connector
- 13. PCB driver board

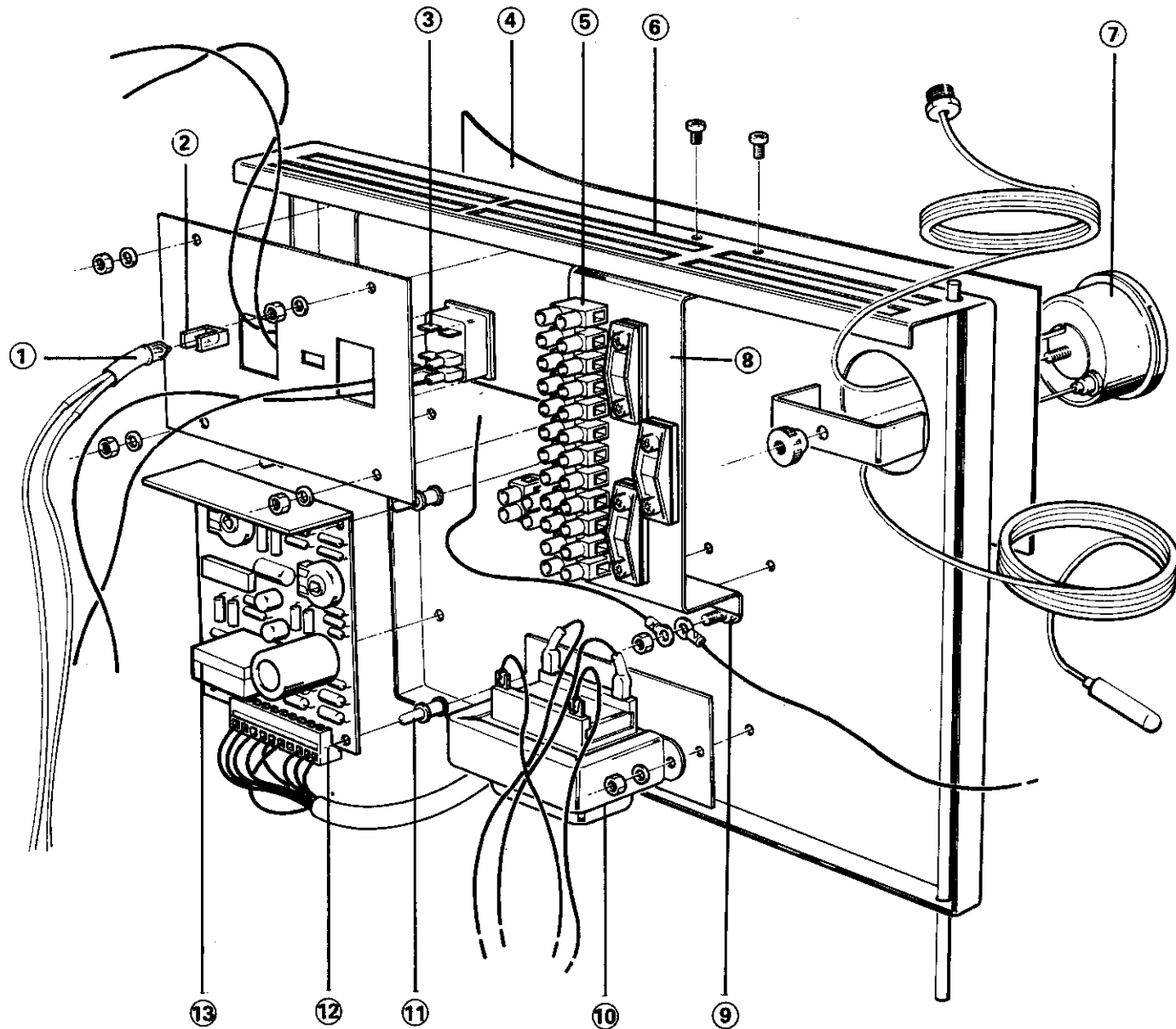

**BOILER CONTROL PANEL**  
(cover plate not shown)

**Fig. 14**

# FAULT FINDING

Before attempting any electrical fault finding, ALWAYS carry out the preliminary electrical system checks as detailed on pages 6–9 of the Instructions for the British Gas Multimeter.

Detailed instructions on the replacement of faulty components are contained in the Servicing section of this publication.

## 1. PILOT WILL NOT LIGHT

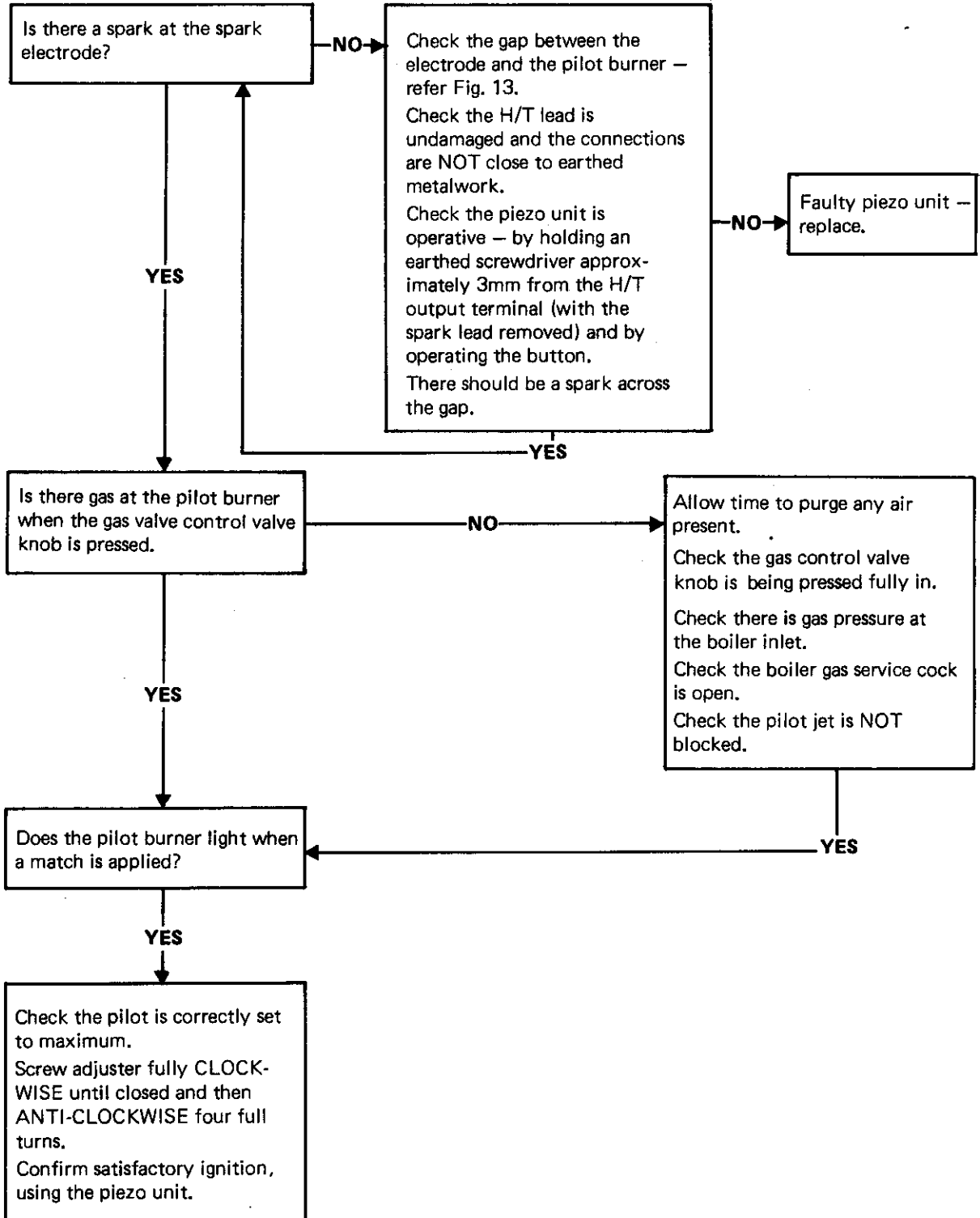



2. PILOT WILL NOT STAY LIT WHEN THE GAS VALVE KNOB IS RELEASED

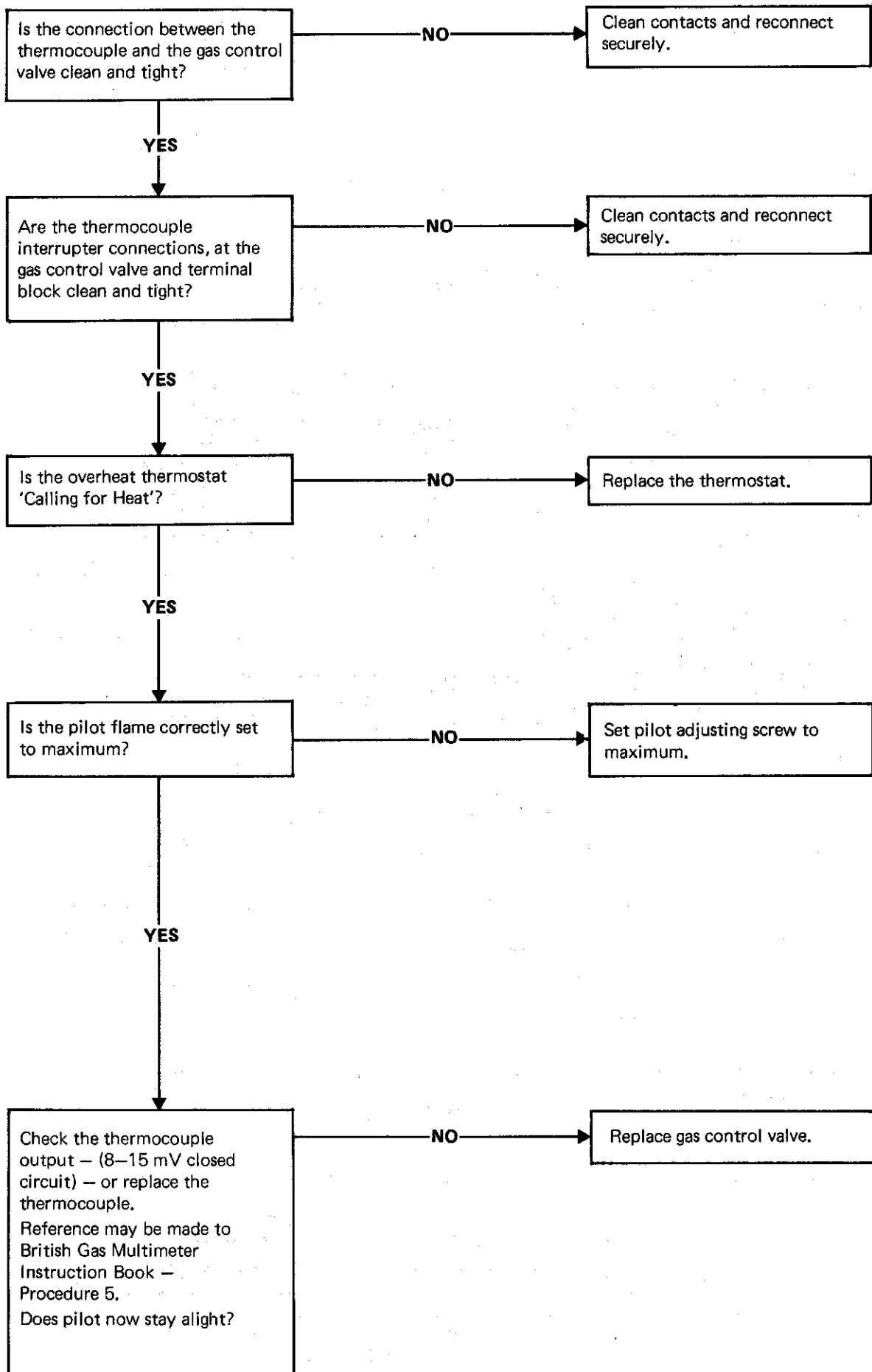

3. PILOT LIT, BUT NO MAINS GAS  
(Central Heating Mode)

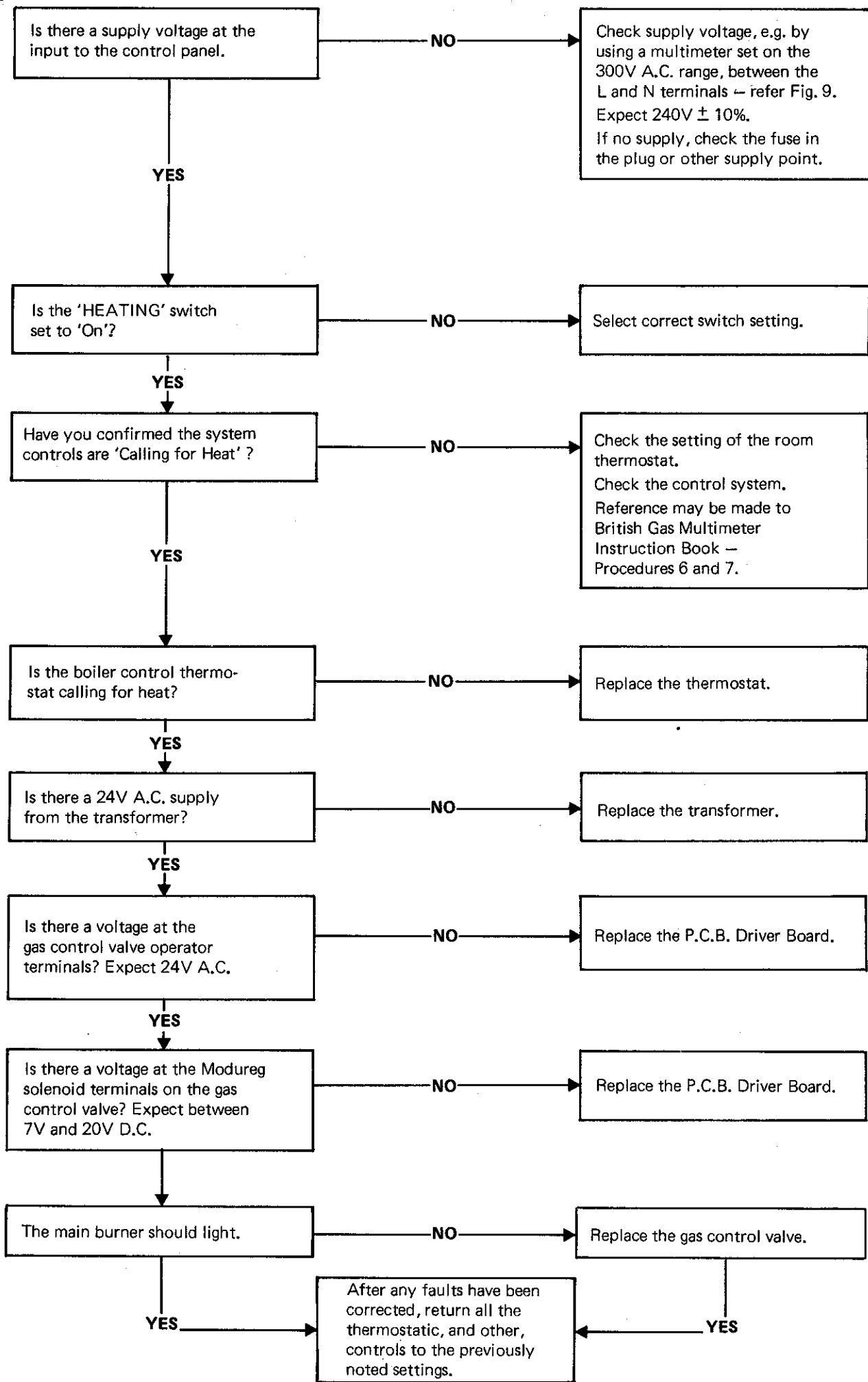

4. PILOT LIT, BUT NO MAINS GAS (DHW Mode)

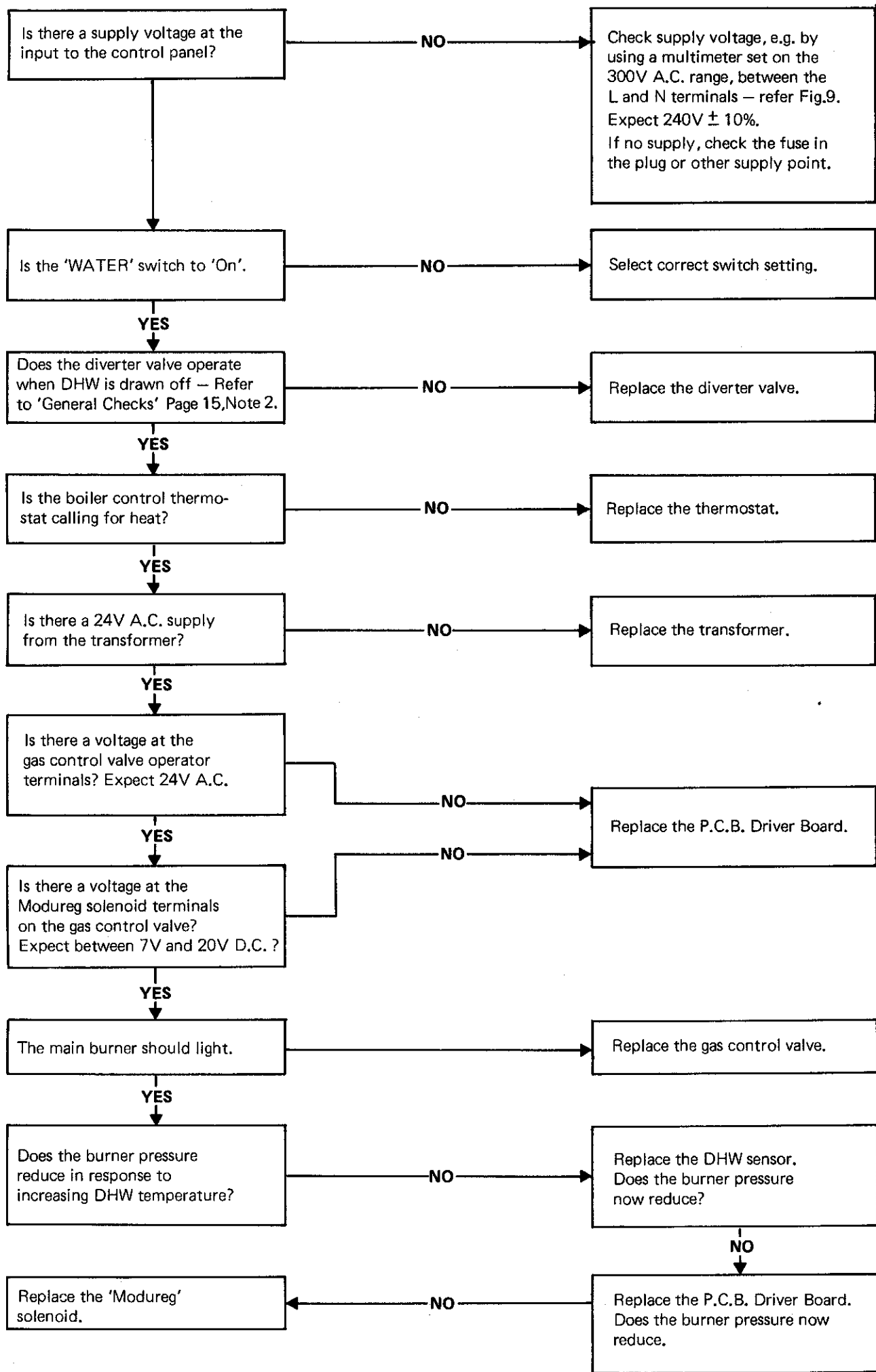

## 5. MAIN BURNER SHUT DOWN BY OVERHEAT THERMOSTATS

- Notes:-**
1. If the boiler has been shut down by overheat thermostat No.1, the pilot flame will be out.
  2. If the boiler has been shut down by overheat thermostat No. 2 ONLY the pilot flame will be alight, but the main burner will not fire.
  3. Before re-setting the thermostat(s) and continuing with the fault finding procedure, ensure that the boiler and system are full of water and free from air locks.

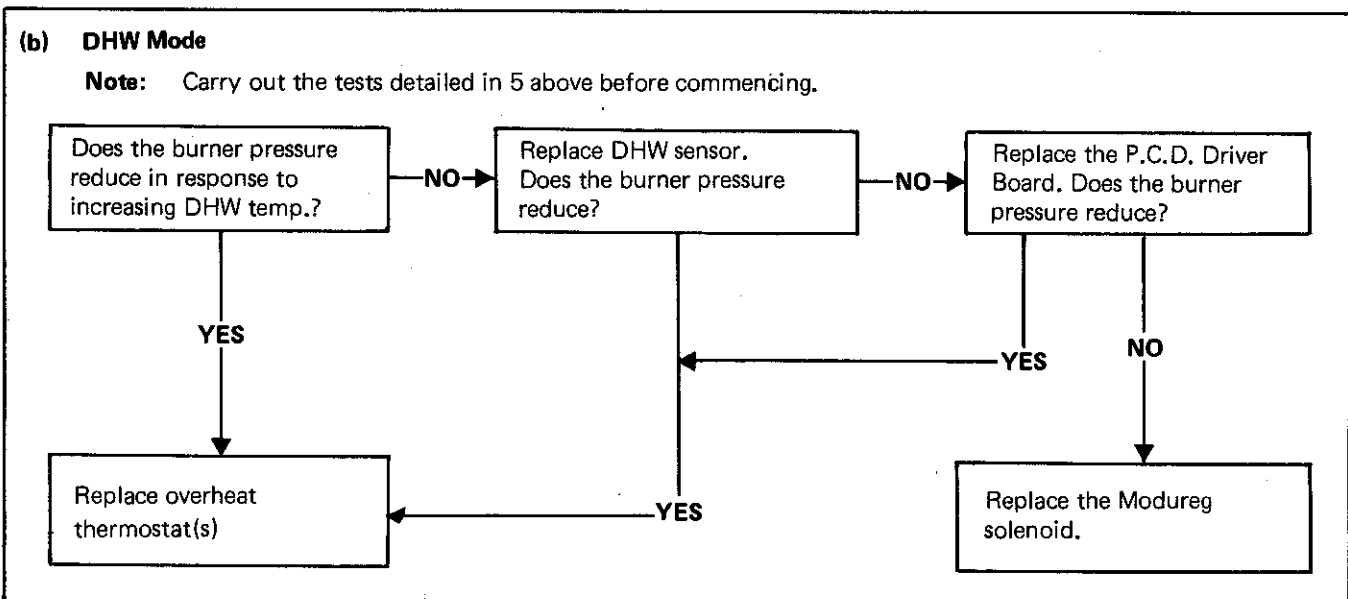
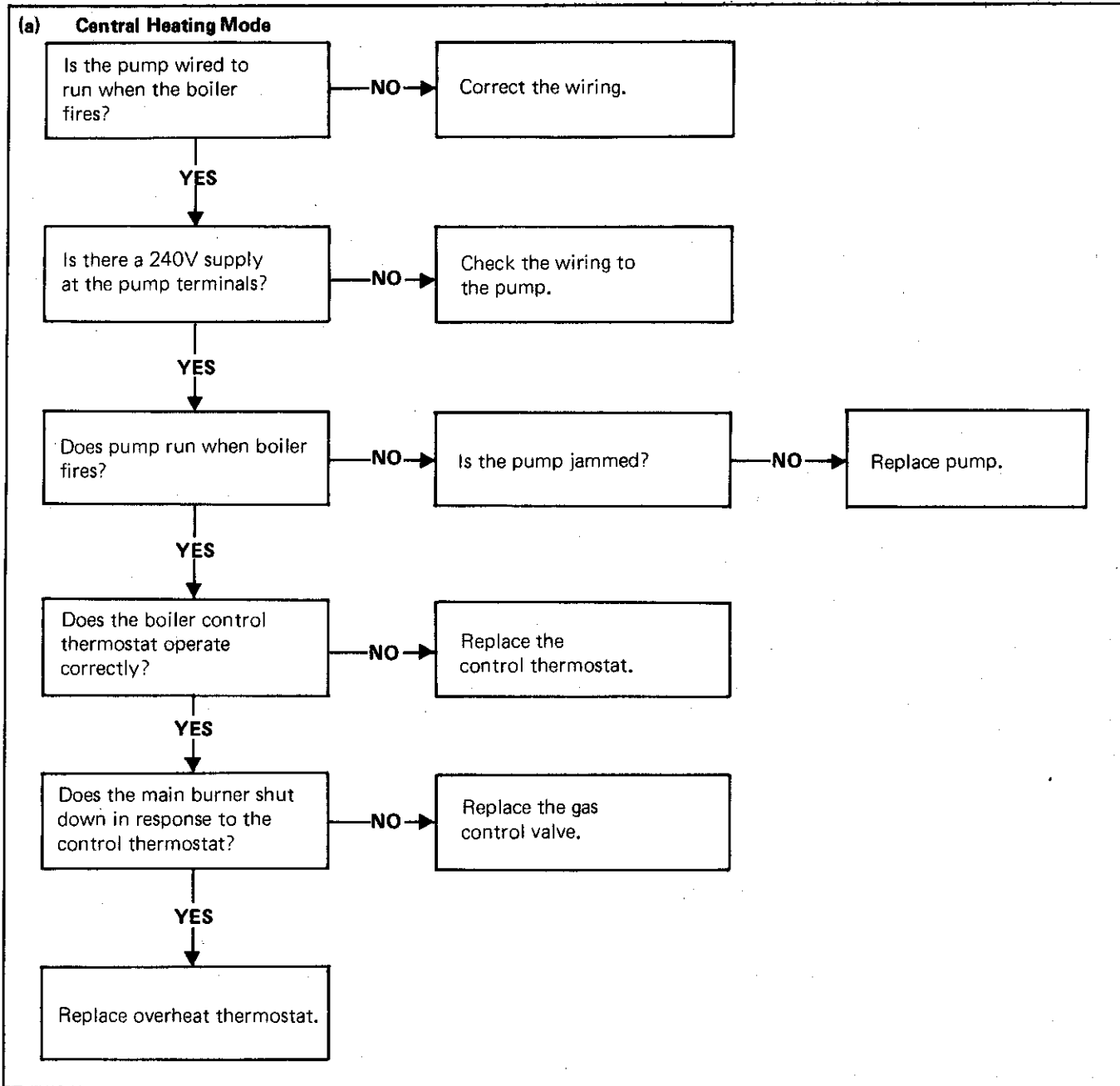

# SHORT LIST OF PARTS

The following list comprises parts commonly required as replacement components due to damage, expendability, or such that their failure or absence is likely to affect safety or performance.

The list is extracted from the British Gas List of Parts, which contains all available spare parts.

Details of the British Gas Lists are held by Gas Regions, STELRAD Distributors and by Merchants.

## IDEAL SPRINT RS.75 COMBINATION GAS BOILER

When ordering spares please quote.

1. Boiler Model
2. Appliance G.C. Number
3. Description
4. Maker's Part Number
5. Quantity

Key No.	G.C. Part No.	Description	No. Off	Maker's Part No.
4.	341 446	Sight-glass assy. comprising sight-glass frame, 2—sight-glass gaskets, 2—M4 Hex. nuts, 2—M4 shakeproof washers	1	189736045
7	392 916	Main burner — FURIGAS type R No. 118 000 020	1	199226064
8	398 064	Main burner injector — Bray Cat. 10 size 2200	1	189776060
9	391 664	Pilot burner — HONEYWELL Q359A—1041 with double orifice injector	1	589040085
10	382 536	Pilot injector — HONEYWELL 45003 508 001 double orifice (0.38/0.35)	1	589040083
12	392 884	½in. BSP HONEYWELL gas control valve V8600N 1017 — 24V	1	586221900
14	341 933	Spark generator — VERNITRON	1	589220086
15	341 505	Spark electrode — VERNITRON 60843 and H.T. lead assy. — 600mm long	1	589220088
16	390 039	Thermocouple — HONEYWELL Q309A—2739 24in. lg.	1	576730052
19	392 929	24V Transformer — HINCHLEY No. 29708	1	589220071
20	341 911	PCB driver board — HONEYWELL	1	589220072
21	341 932	Pressure/temperature gauge — GRUTER	1	589220075
22	392 919	Heating/water switch — ARCO ELECTRIC single pole rocker switch No. C1450 SP VQN black	2	589220073
23	341 461	Neon indicator — READLEADS	3	589730067
25	395 686	Thermostat — boiler control — ESSEX type 495—107	1	589730051
	392 921	Alternative thermostat — boiler control — ELMWOOD No. 2455R—821—4		589730056
26	392 922	Thermostat — overheat 1 with leads — THERMODISC No.44T2131602	1	589220074
26A		Thermostat — overheat 2 — ELMWOOD 2455 RM	1	
27	392 927	Domestic hot water thermistor sensor, HONEYWELL No. T7335 A1004	1	589220041
28	341 954	Domestic hot water diverter valve complete with microswitch and 5 gaskets	1	589220042
30	392 928	Safety valve — R½ x Rc½ — 3 bar — INTER-ALBION No. 2911301	1	589220044
31	389 375	Water pump with gaskets — GRUNDFOS UPS 18—60	1	589030031
52	341 925	Boiler casing assy. white stove enamel (less removable smoked brown fascia) with dimple foil insulation, bottom sealing strip, 3 securing screws and retaining washers including Key No. 4	1	199224030
53	341 567	Glass fascia — smoked brown	1	189760088
54	341 926	Controls compartment lift-off cover — brown stove enamel with name badges and Lighting Instructions	1	199220089
55	341 927	Sealing pack, comprising, 2—sealing strips, 1 pair sealing blocks, pipe sealing clamp and 2—M5 screws	1	199224033

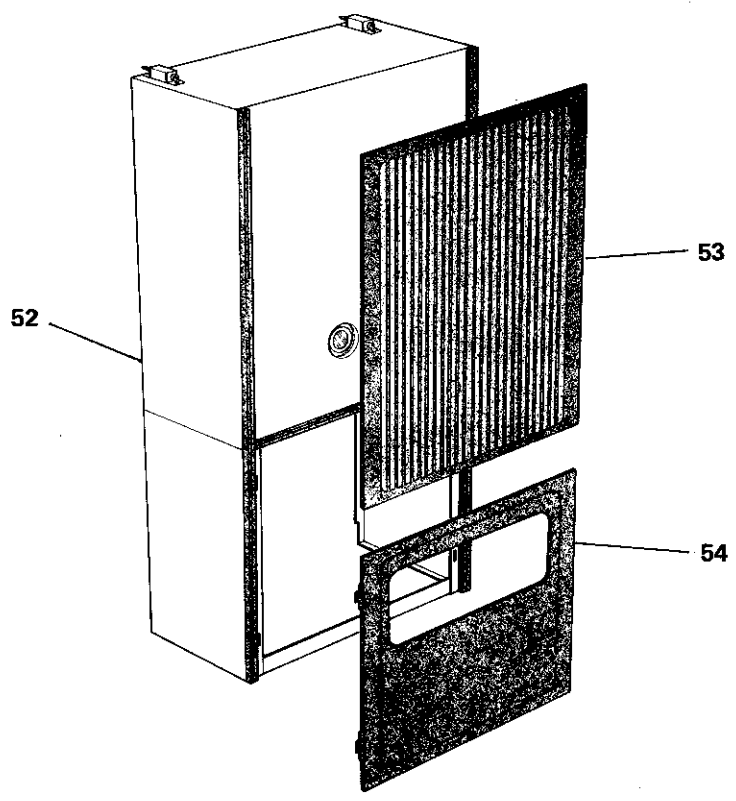

Fig. 15

BOILER CASING — EXPLODED VIEW

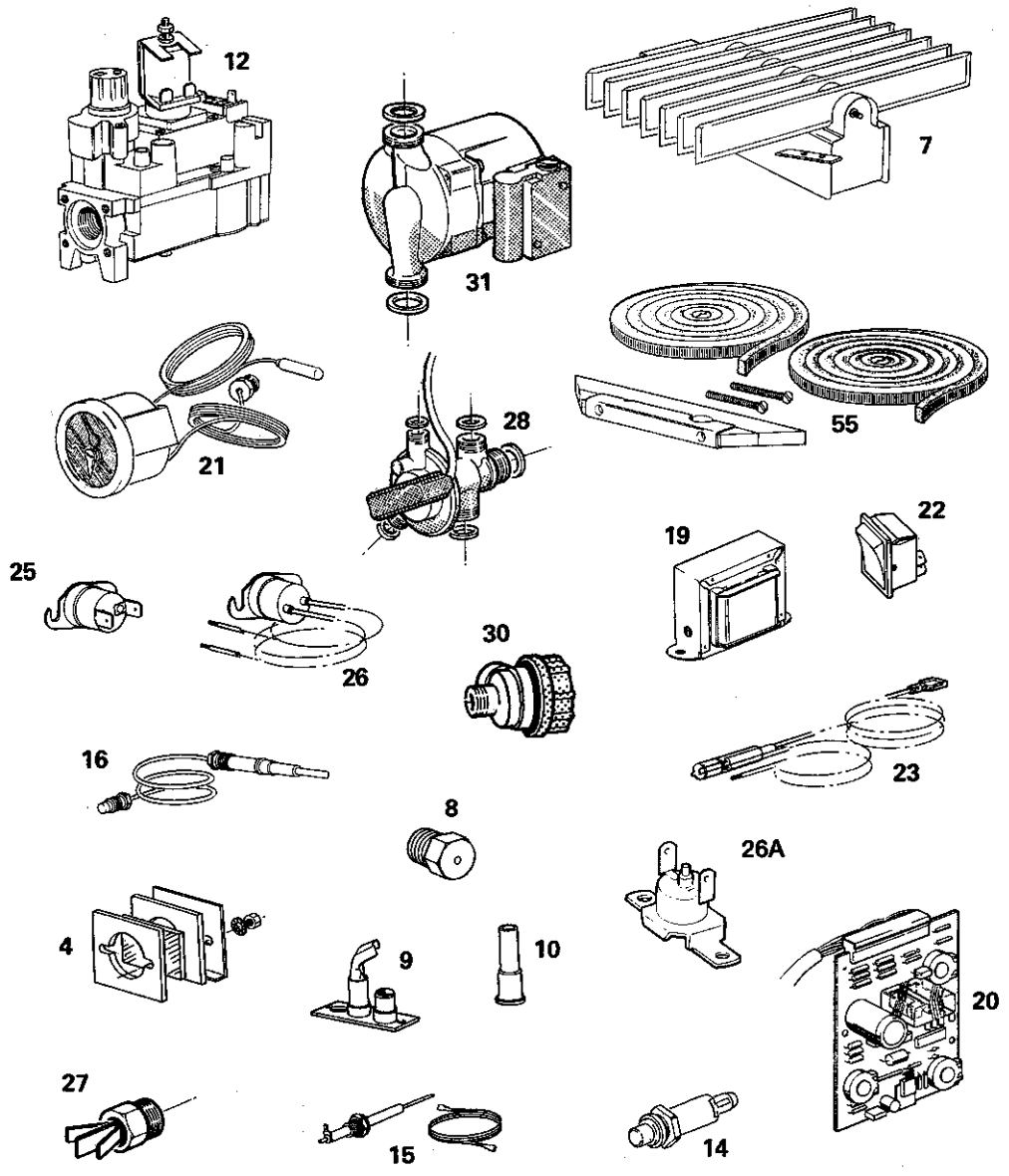

Fig. 16

SMALL PARTS

**CARADON HEATING** pursues a policy of continuing improvement in the design and performance of its products. The right is therefore reserved to vary specification without notice.

**CARADON HEATING** Limited,  
Sales and Marketing,  
P.O. Box 103, National Avenue,  
Kingston upon Hull,  
North Humberside, HU5 4JN.  
Telephone; 0482 492 251.  
Fax; 0482 448 858.

Registration No. London 322 137

Registered Office;  
National Avenue, Kingston upon Hull,  
North Humberside, HU5 4JN.

*A subsidiary of M.B. Caradon p.l.c.*

Printed in England.

116 010 A0 H0425(3)

