

INSTALLATION AND SERVICING

LOGIC Heat 12, 15, 18, 24, 30

For users guide see reverse of book



For details of document amendments, refer to page 3

When replacing any part on this appliance, use only spare parts that you can be assured conform to the safety and performance specification that we require. Do not use reconditioned or copy parts that have not been clearly authorised by Ideal.

For the very latest copy of literature for specification and maintenance practices visit our website www.idealheating.com where you can download the relevant information in PDF format.



NOTES FOR THE INSTALLER

**FOR ANY TECHNICAL QUERIES PLEASE RING THE
IDEAL INSTALLER/TECHNICAL HELPLINE : 01482 445570**

NOTE. BOILER RESET PROCEDURE -

To reset boiler, turn mode knob to reset position and immediately turn knob back to required setting.
The boiler will repeat the ignition sequence.

DOCUMENT AMENDMENTS

Relevant Installation changes implemented in this book from Mod Level A01 (Jun 2010) to A02 (Oct 2010)

Page 4, Table 2

New Sedbuk 2009 figures

Page 8, Gas Supply

New graph added - Gas Cock Pressure Drop

Page 8, Flue Installation

New "IMPORTANT" note added.

Page 10, Frame 1 Boiler Dimensions, Services & Clearances

"Side Flue Only" Table updated

Page 15, Frame 9 Water Treatment

Addition of Scalemaster Gold 100

Page 17, Frame 11 Unpacking

Pack A Contents - New item F added.

Page 26, Frame 25 Connecting the Flue to the Boiler

Key no. 4 updated ref flue seal.

Page 37, Frame 40 Internal Installer Wiring

Updated Y Plan & S Plan diagrams

Page 38, Frame 42 External Electrical Controls

Updated wiring diagram

Page 39, Frame 43 Wiring Diagram

Updated wiring diagram

Short List of Parts diagrams

Page deleted refer to Boiler Assembly Frame

Installer Notification Guidelines

Page deleted

Page 68 - 69 Commissioning Checklist

Forms updated

Boiler Guarantee

Page deleted. Now found in Guarantee /Registration Pack

Ideal Stelrad Group reserve the right to vary specification without notice

GENERAL

Table 1 - General Data

| Ideal Logic Heat | | | 12 | 15 | 18 | 24 | 30 |
|---|---------------------------|---------|---|-------------|-------------|--------------|--------------|
| Gas supply | | | 2H - G20 - 20mbar | | | | |
| Gas Supply Connection | | | 15mm copper compression | | | | |
| Injector Size | (mm) | | 4.15 | 4.15 | 4.15 | 4.15 | 4.65 |
| Flow Connection | Central Heating | | 22mm copper compression | | | | |
| Return Connection | Central Heating | | 22mm copper compression | | | | |
| Flue Terminal Diameter - Turret | mm (in) | | 100 (4) | | | | |
| Flue Terminal Diameter - Rear Flue Outlet (55/80) | mm (in) | | 80 (3) | | | | |
| Average Flue Temp-Mass Flow Rate | 56°C - 5g/s | | 56°C - 5g/s | 56°C - 6g/s | 58°C - 8g/s | 63°C - 10g/s | 69°C - 13g/s |
| Max. static water head | m (ft.) | | 30.5 (100) | | | | |
| Min. static water head | m (ft.) | | 0.45 (1.5) | | | | |
| Max. Working Pressure (Sealed Systems) | bar (lb/in ²) | | 2.5 (36.3) | | | | |
| Electrical Supply | | | 230 V ~ 50 Hz. | | | | |
| Power Consumption | W | | 23 | 26 | 31 | 46 | 48 |
| Fuse Rating | | | External : 3A Internal : T4H HRC L250 V | | | | |
| Water content | litre (gal) | | 1.2 (0.26) | | | | |
| Packaged Weight | kg (lb) | | 28.7 (63.3) | 28.7 (63.3) | 28.7 (63.3) | 28.7 (63.3) | 28.7 (63.3) |
| Maximum Installation Weight | kg (lb) | | 23 (51) | 23 (51) | 23 (51) | 23 (51) | 23 (51) |
| Boiler Casing Size | Height | mm (in) | 700 (27.5) | | | | |
| | Width | mm (in) | 395 (15.5) | | | | |
| | Depth | mm (in) | 278 (11) | | | | |

Table 2 - Performance Data - Central Heating

| | | | 12 | | 15 | | 18 | | 24 | | 30 | |
|------------------------------------|-----------------------|----------------------|----------|----------|----------|----------|----------|----------|----------|----------|----------|-----------|
| | | | MIN | MAX | MIN | MAX | MIN | MAX | MIN | MAX | MIN | MAX |
| Boiler Input : | | | | | | | | | | | | |
| Boiler Input 'Q' | Nett CV | kW | 4.9 | 12.1 | 4.9 | 15.1 | 4.9 | 18.1 | 4.9 | 24.3 | 6.1 | 30.4 |
| | | (Btu/h) | (16,600) | (41,300) | (16,600) | (51,520) | (16,600) | (61,800) | (16,600) | (82,900) | (20,700) | (103,600) |
| | Gross CV | kW | 5.4 | 13.4 | 5.4 | 16.6 | 5.4 | 20.1 | 5.4 | 27.0 | 6.7 | 33.7 |
| | | (Btu/h) | (18,400) | (45,800) | (18,400) | (56,800) | (18,400) | (68,600) | (18,400) | (92,000) | (23,000) | (115,000) |
| Gas Consumption | | l/s | 0.139 | 0.346 | 0.139 | 0.427 | 0.139 | 0.52 | 0.139 | 0.698 | 0.173 | 0.871 |
| | | (ft ³ /h) | (17.8) | (44.1) | (17.8) | (54.7) | (17.8) | (66.1) | (17.8) | (89) | (22) | (111) |
| Boiler Output : | | | | | | | | | | | | |
| Non Condensing | | kW | 4.8 | 12.0 | 4.8 | 15.0 | 4.8 | 18.0 | 4.8 | 24.2 | 6.1 | 30.3 |
| | 70°C Mean Water temp. | (Btu/h) | (16,500) | (41,100) | (16,500) | (51,300) | (16,500) | (61,600) | (16,500) | (82,600) | (20,700) | (103,300) |
| Condensing | | kW | 5.1 | 13.0 | 5.1 | 15.9 | 5.1 | 19.1 | 5.1 | 25.6 | 6.4 | 31.0 |
| | 40°C Mean Water temp. | (Btu/h) | (17,500) | (44,600) | (17,500) | (54,250) | 17,500 | (65,100) | (17,500) | (87,400) | (21,800) | (105,800) |
| Seasonal efficiency* (SEDBUK) 2005 | | | 91.2% | | 91.1% | | 91% | | 91% | | 91.1% | |
| Seasonal efficiency* (SEDBUK) 2009 | | | 89.4% | | 89.3% | | 89.2% | | 89.5% | | 89.6% | |
| NOx Classification | | | CLASS 5 | | | | | | | | | |

* The value is used in the UK Government's Standard Assessment Procedure (SAP) for energy rating of dwellings. The test data from which it has been calculated have been certified by a notified body.

Note. Gas consumption is calculated using a calorific value of 38.7 MJ/m³ (1038 Btu/ft³) gross or 34.9 MJ/m³ (935 Btu/ft³) nett

To obtain the gas consumption at a different calorific value:

- For l/s - divide the gross heat input (kW) by the gross C.V. of the gas (MJ/m³)
- For ft³/h - divide the gross heat input (Btu/h) by the gross C.V. of the gas (Btu/ft³)
- For m³/h - multiply l/s by 3.6

Key to symbols

GB = United Kingdom **IE** = Ireland (Countries of destination)

PMS = Maximum operating pressure of water

C₁₃ C₃₃ C₅₃ = A room sealed appliance designed for connection via ducts to a horizontal or vertical terminal, which admits fresh air to the burner and discharges the products of combustion to the outside through orifices which, in this case, are concentric. The fan is up stream of the combustion chamber.

I_{2H} = An appliance designed for use on 2nd Family gas, Group H only.

GENERAL

IDEAL LOGIC HEAT

Natural Gas only

| Boiler size | G.C. Appliance No. (Benchmark No.) | PI No. |
|-------------|---------------------------------------|----------|
| 12 | 41-399-99 | 86 CL 08 |
| 15 | 41-409-93 | 86 CL 08 |
| 18 | 41-409-94 | 86 CL 08 |
| 24 | 41-409-95 | 86 CL 08 |
| 30 | 41-409-96 | 86 CL 08 |

Destination Country: GB, IE

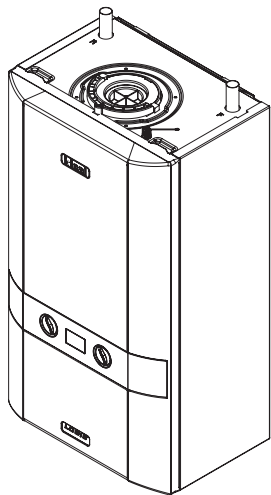

CONTENTS

| | |
|---|-----------|
| Air Supply | 9 |
| Benchmark Commissioning Checklist | 58 |
| Boiler Clearances | 10 |
| Boiler Exploded Diagram | 15 |
| Condensate Drain | 9, 31, 47 |
| Commissioning & Testing | 36 |
| Electrical Connections | 32 |
| Electrical Supply | 9 |
| Fault Finding | 51 |
| Flue Fitting | 17 |
| Flue Installation | 8 |
| Gas Safety Regulations | 7 |
| Gas Supply | 8 |
| Initial Lighting | 37 |
| Installation | 17-38 |
| Safe Handling | 6 |
| Servicing | 39-50 |
| Short List of Parts | 56 |
| Thermostatic Radiator Valves | 9 |
| Water and Systems | 9,11-14 |
| Water & Gas Connections | 32 |
| Water Treatment | 14 |
| Wiring Diagram | 35 |

For GB, to comply with Building Regulations Part L1 (Part 6 in Scotland) the boiler should be fitted in accordance with the manufacturer's instructions. Self-certification that the boiler has been installed to comply with Building Regulations can be demonstrated by completing and signing the Benchmark Commissioning Checklist.

Before installing this boiler, read the Code of Practice sheet at the rear of this book.

BENCHMARK COMMISSIONING CHECKLIST DETAILS

| Boiler | Page | Page | |
|---|--------------------|--|--------------------|
| Make and model..... | 5 | Burner operating pressure | n/a |
| Appliance serial no. on data badge | Front Cover | Central heating flow temp. | measure and record |
| SEDBUK No. %..... | 4 | Central heating return temp. | measure and record |
| Controls | | For combination boilers only | |
| Time and temperature control to heating | 34 | Scale reducer | 14 |
| Time and temperature control to hot water | 34 | <i>Hot water mode</i> | |
| Heating zone valves..... | n/a | Heat input..... | to be calculated |
| TRV's..... | 9 | Max. operating burner pressure | n/a |
| Auto bypass | 9 | Max. operating water pressure..... | measure & record |
| Boiler interlock..... | 9 | Cold water inlet temp | measure & record |
| For | all boilers | Hot water outlet temp | measure & record |
| Flushing to BS.7593..... | 14 | Water flow rate at max. setting..... | measure & record |
| Inhibitor | 14 | For condensing boilers only | |
| <i>Central heating mode</i> | | Condensate drain..... | 31 |
| Heat input..... | to be calculated | For all boilers: complete, sign & hand over to customer | |

For assistance see Technical Helpline on the back page

NOTE TO THE INSTALLER: COMPLETE THE BENCHMARK COMMISSIONING CHECKLIST AND LEAVE THESE INSTRUCTIONS WITH APPLIANCE



INTRODUCTION

The **Logic Heat** range of boilers are wall mounted, full sequence, automatic spark ignition, low water content, fanned flue, high efficiency, condensing, heating only gas boilers.

Note. *Due to the high efficiency of the boiler a plume of water vapour will form at the terminal during operation.*

Central heating (CH) output is fully modulating with a range of:

| | |
|----|---|
| 12 | 4.8 to 12kW (16,500 to 41,100 Btu/h) |
| 15 | 4.8 to 15kW (16,500 to 51,300 Btu/h) |
| 18 | 4.8 to 18kW (16,500 to 61,600 Btu/h) |
| 24 | 4.8 to 24.2kW (16,500 to 82,600 Btu/h) |
| 30 | 6.1 to 30.3kW (20,700 to 103,300 Btu/h) |

A variable CH temperature control is fitted on the user control.

The boiler includes as standard:

- Boiler frost protection

The boiler casing is of white painted mild steel.

The boiler temperature control is visibly located in the control panel on the front of the boiler.

The heat exchanger is manufactured from cast aluminium.

Note that these boilers cannot be used on systems which include gravity circulation.

The boiler is suitable for connection to fully pumped open vented or sealed water systems. Adequate arrangements for completely draining the system by provision of drain cocks **MUST** be provided in the installation pipework.

Pipework from the boiler is routed upwards.

A rear flue outlet kit (55/80) is available which provides a compact installation.

OPERATION

When there is a demand for CH, the heating system is supplied at the selected temperature of between 30°C and 80°C.

The boiler features a comprehensive diagnostic system which gives detailed information on the boiler status when operating, and performance of key components to aid commissioning and fault finding.

SAFE HANDLING

This boiler may require 2 or more operatives to move it to its installation site, remove it from its packaging base and during movement into its installation location. Manoeuvring the boiler may include the use of a sack truck and involve lifting, pushing and pulling.

Caution should be exercised during these operations.

Operatives should be knowledgeable in handling techniques when performing these tasks and the following precautions should be considered:

- Grip the boiler at the base.
- Be physically capable.
- Use personal protective equipment as appropriate, e.g. gloves, safety footwear.

During all manoeuvres and handling actions, every attempt should be made to ensure the following unless unavoidable and/or the weight is light.

- Keep back straight.
- Avoid twisting at the waist.
- Avoid upper body/top heavy bending.
- Always grip with the palm of the hand.
- Use designated hand holds.
- Keep load as close to the body as possible.
- Always use assistance if required.

OPTIONAL EXTRA KITS

- **Horizontal Flue Terminal** (600mm long)
- **Horizontal Flue Terminal** (1000mm long)
- **Horizontal Flue Telescopic**
- **Rear Flue Outlet Kit (55/80)**
- **Flue Extension Ducts** (1000mm long)
 - 12 - 24 up to 9m
 - 30 up to 8m
- **Flue Finishing Kit (60/100)**
- **Flue Finishing Kit (55/80)**
- **90° Elbow Kit** (maximum per installation).
 - 12 - 30 up to 6 elbows
- **45° Elbow Kit** (maximum per installation).
 - 12 - 30 up to 6 elbows
- **Concentric Flue Screw Retaining Kit**
- **Roof Flue Kit** (to a maximum of 7.5m)
- **Powered Vertical Flue Kit** (5m primary and 17m secondary is a typical maximum length. For alternative details refer to Powered Vertical Instructions)
- **Weather Collar (Universal)**
- **Weather Collar (Flat Roof)**
- **Stand-Off Kit**
- **High Level Flue Outlet Kit - 60/100**
- **High Level Flue Outlet Kit - 55/80 (Rear Flue only)**
- **Flue Deflector Kit**
- **Condensate Pump Kit**
- **Weather Compensation Kit**
- **Adjustable Flue Support Bracket**
- **Balcony Flue Kit**
- **Security Bracket Kit**
- **Terminal Wall Plate Kit**

SAFETY

Current Gas Safety (installation and use) regulations or rules in force:

The appliance is suitable only for installation in GB and IE and should be installed in accordance with the rules in force.

In GB, the installation must be carried out by a Gas Safe Registered Engineer. It must be carried out in accordance with the relevant requirements of the:

- Gas Safety (Installation and Use) Regulations
- The appropriate Building Regulations either The Building Regulations, The Building Regulations (Scotland), Building Regulations (Northern Ireland).
- The Water Fittings Regulations or Water byelaws in Scotland.
- The Current I.E.E. Wiring Regulations.

Where no specific instructions are given, reference should be made to the relevant British Standard Code of Practice.

In IE, the installation must be carried out by a Registered Gas Installer (RGII) and installed in accordance with the current edition of I.S.813 "Domestic Gas Installations", the current Building Regulations and reference should be made to the current ETCI rules for electrical installation.

Detailed recommendations are contained in the following British Standard Codes of Practice:

- BS. 5440:1** Flues (for gas appliances of rated input not exceeding 70 kW).
- BS. 5440:2** Ventilation (for gas appliances of rated input not exceeding 70 kW).
- BSEN. 12828:2003** Heating Systems in buildings: Design for water based heating systems.
- BSEN 12831:2003** Heating Systems in buildings: Method for calculation of the design heat load.
- BSEN 14336:2004** Heating Systems in buildings: Installation and commissioning of water based heating systems.
- BS. 5546** Installation of gas hot water supplies for domestic purposes (2nd Family Gases)
- BS. 6798** Installation of gas fired hot water boilers of rated input not exceeding 70 kW.
- BS. 6891** Low pressure installation pipes.

Health & Safety Document No. 635.

The Electricity at Work Regulations, 1989.

The manufacturer's notes must NOT be taken, in any way, as overriding statutory obligations.

IMPORTANT. These appliances are CE certificated for safety and performance. It is, therefore, important that no external control devices, e.g. flue dampers, economisers etc., are directly connected to these appliances unless covered by these Installation and Servicing Instructions or as otherwise recommended by **Ideal Stelrad Group** in writing. If in doubt please enquire.

Any direct connection of a control device not approved by **Ideal Stelrad Group** could invalidate the certification and the normal appliance warranty. It could also infringe the Gas Safety Regulations and the above regulations.

SAFE HANDLING OF SUBSTANCES

No asbestos, mercury or CFCs are included in any part of the boiler or its manufacture.

LOCATION OF BOILER

The boiler must be installed on a flat and vertical internal wall, capable of adequately supporting the weight of the boiler and any ancillary equipment.

The boiler may be fitted on a combustible wall and insulation between the wall and the boiler is not necessary, unless required by the local authority.

For electrical safety reasons there must be no access available from the back of the boiler.

The boiler must not be fitted outside.

Timber Framed Buildings

If the boiler is to be fitted in a timber framed building it should be fitted in accordance with the Institute of Gas Engineering document IGE/UP/7:1998.

Bathroom Installations

This appliance is rated **IP20**.

The boiler may be installed in any room or internal space, although particular attention is drawn to the requirements of the current IEE (BS.7671) Wiring Regulations and the electrical provisions of the building regulations applicable in Scotland, with respect to the installation of the boiler in a room or internal space containing a bath or shower. For IE reference should be made to the current ETCI rules for electrical installations and I.S. 813:2002.

If the appliance is to be installed in a room containing a bath or shower then, providing water jets are not going to be used for cleaning purposes (as in communal baths/showers), the appliance must be installed beyond Zone 2, as detailed in BS.7671.

Compartment Installations

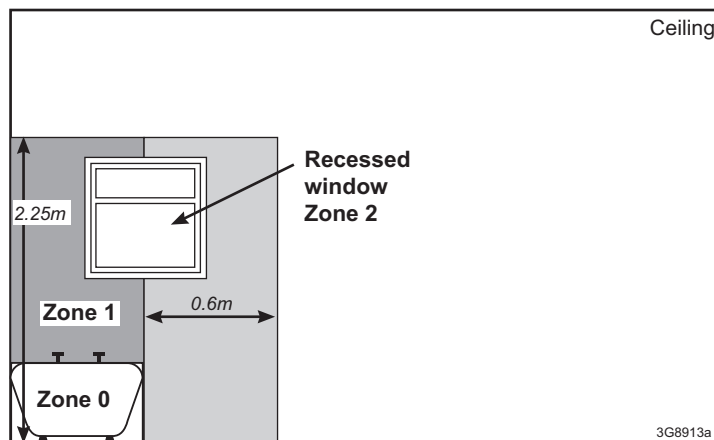

A compartment used to enclose the boiler should be designed and constructed specially for this purpose.

An existing cupboard or compartment may be used, provided that it is modified for the purpose.

In both cases, details of essential features of cupboard / compartment design, including airing cupboard installation, are to conform to the following:

- BS 6798 (No cupboard ventilation is required - see 'Air Supply' for details).
- The position selected for installation MUST allow adequate space for servicing in front of the boiler.
- For the minimum clearances required for safety and subsequent service, see the wall mounting template and Frame 1. In addition, sufficient space may be required to allow lifting access to the wall mounting plate.

GAS SUPPLY

The local gas supplier should be consulted, at the installation planning stage, in order to establish the availability of an adequate supply of gas. An existing service pipe must NOT be used without prior consultation with the local gas supplier.

The boiler MUST be installed on a gas supply with a governed meter only.

A gas meter can only be connected by the local gas supplier or by a Gas Safe Registered Engineer. In IE by a Registered Gas Installer (RGII).

An existing meter should be checked, preferably by the gas supplier, to ensure that the meter is adequate to deal with the rate of gas supply required.

It is the responsibility of the Gas Installer to size the gas Installer to size the gas installation pipework in accordance with BS6891:2005. Whilst the principle of the 1:1 gas valve ensures the Logic range is able to deliver it's full output at inlet pressures as low as 14mb, other gas appliances in the property may not be as tolerant. When operating pressures are found to be below the minimum meter outlet of 19mb these should be checked to ensure this is adequate for correct and safe operation.

Allowing for the acceptable pressure loss of 1mb across the installation pipework, it can be assumed that a minimum permitted operating pressure of 18mb will be delivered to the inlet of the appliance. (Reference BS 6400-1 Clause 6.2 Pressure Absorption).

The external gas cock could further reduce the operating pressure when measured at its test point. The pressure drop is relative to the heat input to the boiler (kW), refer to graph below.

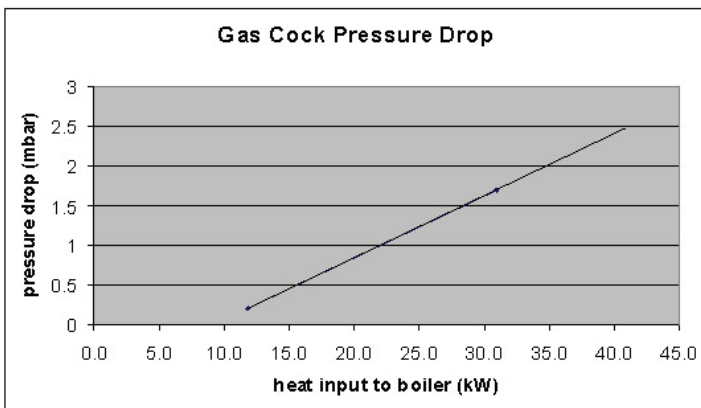

IMPORTANT.

Installation pipes must be fitted in accordance with BS.6891. In IE refer to IS.813:2002.

The complete installation MUST be tested for gas tightness and purged as described in the above code.

FLUE INSTALLATION

Plumbing will occur at the terminal so terminal positions where this could cause a nuisance should be avoided.

The flue must be installed in accordance with the recommendations of BS. 5440-1: 2008. In IE refer to I.S. 813:2002.

The following notes are intended for general guidance:

1. The boiler MUST be installed so that the terminal is exposed to external air.
2. It is important that the position of the terminal allows the free passage of air across it at all times.
3. Minimum acceptable spacing from the terminal to obstructions and ventilation openings are specified in Table 3.

4. Where the lowest part of the terminal is fitted less than 2m (6'6") above a balcony, above ground or above a flat roof to which people have access then the terminal MUST be protected by a purpose designed guard.

Terminal guards are available from boiler suppliers. (Ask for TFC flue guard model no. K6 - round, plastic coated). In case of difficulty contact:

Grasslin (UK) Ltd. Tel. + 44 (0) 01732 359 888
 Tower House, Vale Rise Fax. + 44 (0) 01732 354 445
 Tonbridge. Kent TN9 1TB www.tfc-group.co.uk

Ensure that the guard is fitted centrally.

5. The flue assembly shall be so placed or shielded as to prevent ignition or damage to any part of any building.
6. The air inlet/products outlet duct and the terminal of the boiler MUST NOT be closer than 25mm (1") to combustible material. Detailed recommendations on the protection of combustible material are given in BS. 5440-1:2008.

IMPORTANT. It is essential to ensure, in practice, that products of combustion discharging from the terminal cannot re-enter the building or buildings through any openings into the building such as ventilators, windows, doors, or other sources of natural air infiltration, such as forced ventilation openings etc.

If products of combustion re-entry is identified or suspected this should be immediately investigated and corrected following the guidance provided in the current Gas Industry Unsafe Situation Procedure.

Table 3 - Balanced Flue Terminal Position

| Flue Terminal Positions | Min. Spacing* |
|---|----------------------------|
| 1. Directly below, above or alongside an opening window, air vent or other ventilation opening. | 300mm (12") |
| 2. Below guttering, drain pipes or soil pipes. <i>BS5440-1 2008</i> | 25mm (1")* 75mm (3") |
| 3. Below eaves. <i>BS5440-1 2008</i> | 25mm (1")* 200mm (8") |
| 4. Below balconies or a car port roof. <i>BS5440-1 2008</i> | 25mm (1")* 200mm (8") |
| 5. From vertical drain pipes or soil pipes. <i>BS5440-1 2008</i> | 25mm (1")* 150mm (6") |
| 6. From an internal or external corner or to a boundary along side the terminal. <i>BS5440-1 2008</i> | 25mm (1")* 300mm (12") |
| 7. Above adjacent ground, roof or balcony level. | 300mm (12") |
| 8. From a surface or a boundary facing the terminal. | 600mm (24") |
| 9. From a terminal facing a terminal. | 1,200mm (48") |
| 10. From an opening in a car port (e.g. door or window) into dwelling. | 1,200mm (48") |
| 11. Vertically from a terminal on the same wall. | 1,500mm (60") |
| 12. Horizontally from a terminal on the wall. | 300mm (12") |
| Vertical Terminals | |
| 13. Above the roof pitch with roof slope of all angles. Above flat roof. | 300mm (12") 300mm (12") |
| 14. From a single wall face. From corner walls. | 300mm (12") 300mm (12") |
| 15. Below velux window | 2000mm (79") |
| 16. Above or side of velux window | 600mm (24") |

* Only one reduction down to 25mm is allowable per installation otherwise BS5440-1 2008 dimensions must be followed.

GENERAL

TERMINAL

The terminal assembly can be adapted to accommodate various wall thicknesses. Refer to Frame 13 .

AIR SUPPLY

It is NOT necessary to have a purpose-provided air vent in the room or internal space in which the boiler is installed. Neither is it necessary to ventilate a cupboard or compartment in which the boiler is installed, due to the low surface temperatures of the boiler casing during operation; therefore the requirements of BS 6798, Clause 12, and BS 5440:2 may be disregarded.

WATER CIRCULATION SYSTEM

IMPORTANT.

A minimum length of 1 metre of copper pipe MUST be fitted to both flow and return connections from the boiler before connection to any plastic piping.

The central heating system should be in accordance with BS.6798 and, in addition, for smallbore and microbore systems, BS.5449.

Heat Exchanger Pressure Loss

| Boiler Size | | 12 | 15 | 18 | 24 | 30 |
|-------------------|-------|--------|--------|--------|--------|---------|
| Boiler Output | kW | 12 | 15 | 18 | 24.2 | 30.3 |
| | But/H | 41,100 | 51,300 | 61,600 | 82,600 | 103,300 |
| Water Flow Rate | l/min | 8.6 | 10.7 | 13 | 17.2 | 21.5 |
| | g/min | (1.9) | (2.4) | (2.8) | (3.8) | (4.7) |
| Temp Differential | °C | 20 | 20 | 20 | 20 | 20 |
| | °F | 36 | 36 | 36 | 36 | 36 |
| Pressure Loss | M.Wg | 0.5 | 0.7 | 1.0 | 1.6 | 2.4 |
| | FT.WG | 1.7 | 2.3 | 3.1 | 5.2 | 8.0 |

WATER TREATMENT - see Frame 9

BOILER CONTROL INTERLOCKS

Central heating systems controls should be installed to ensure the boiler is switched off when there is no demand for heating, in compliance with Building Regulations.

Heating systems utilising full thermostatic radiator valve control of temperature in individual rooms should also be fitted with a room thermostat controlling the temperature in a space served by radiators not fitted with such a valve.

When thermostatic radiator valves are used, the space heating temperature control over a living / dining area or hallway having a heating requirement of at least 10% of the minimum boiler heat output should be achieved using a room thermostat, whilst other rooms are individually controlled by thermostatic radiator valves. However, if the system employs thermostatic radiator valves on all radiators, or two port valves, then a bypass circuit must be fitted with an automatic bypass valve to ensure a flow of water should all valves be in the closed position.

ELECTRICAL SUPPLY

WARNING.

This appliance must be earthed.

Wiring external to the appliance MUST be in accordance with the current I.E.E. (BS.7671) Wiring Regulations and any local regulations which apply. For IE reference should be made to the current ETCI rules for electrical installations.

The mains supply to the boiler and system wiring centre shall be through one common fused double pole isolator. For new heating systems, and where practicable replacement boiler installation, the isolator shall be situated adjacent to the appliance.

NOTE. THE APPLIANCE MUST BE WIRED WITH A PERMANENT LIVE SUPPLY. THE SYSTEM PUMP MUST BE WIRED TO THE BOILER (SEE FRAME 41). THE BOILER WARRANTY WILL BE INVALID IF THIS REQUIREMENT IS NOT COMPLIED WITH.

CONDENSATE DRAIN

Refer to Frames 36 & 37

A condensate drain is provided on the boiler. This drain must be connected to a drainage point on site. All pipework and fittings in the condensate drainage system MUST be made of plastic - *no other materials may be used.*

IMPORTANT.

Any external runs must be in accordance with BS 6798.

The drain outlet on the boiler is sized for standard 21.5mm (3/4") overflow pipe. It is a universal fitting to allow use of different brands of pipework.

GENERAL

1 BOILER DIMENSIONS, SERVICES & CLEARANCES

all dimensions in mm

The boiler connections are made on the boiler connection tails. Refer to Frame38.

The following minimum clearances must be maintained for operation and servicing.

Additional space will be required for installation, depending upon site conditions.

Side and Rear Flue

a. Provided that the flue hole is cut accurately, e.g. with a core drill, the flue can be installed from inside the building where

wall thicknesses do not exceed 600mm (24"). Where the space into which the boiler is going to be installed is less than the length of flue required the flue must be fitted from the outside.

Installation from inside ONLY

b. If a core boring tool is to be used inside the building the space in which the boiler is to be installed must be at least wide enough to accommodate the tool.

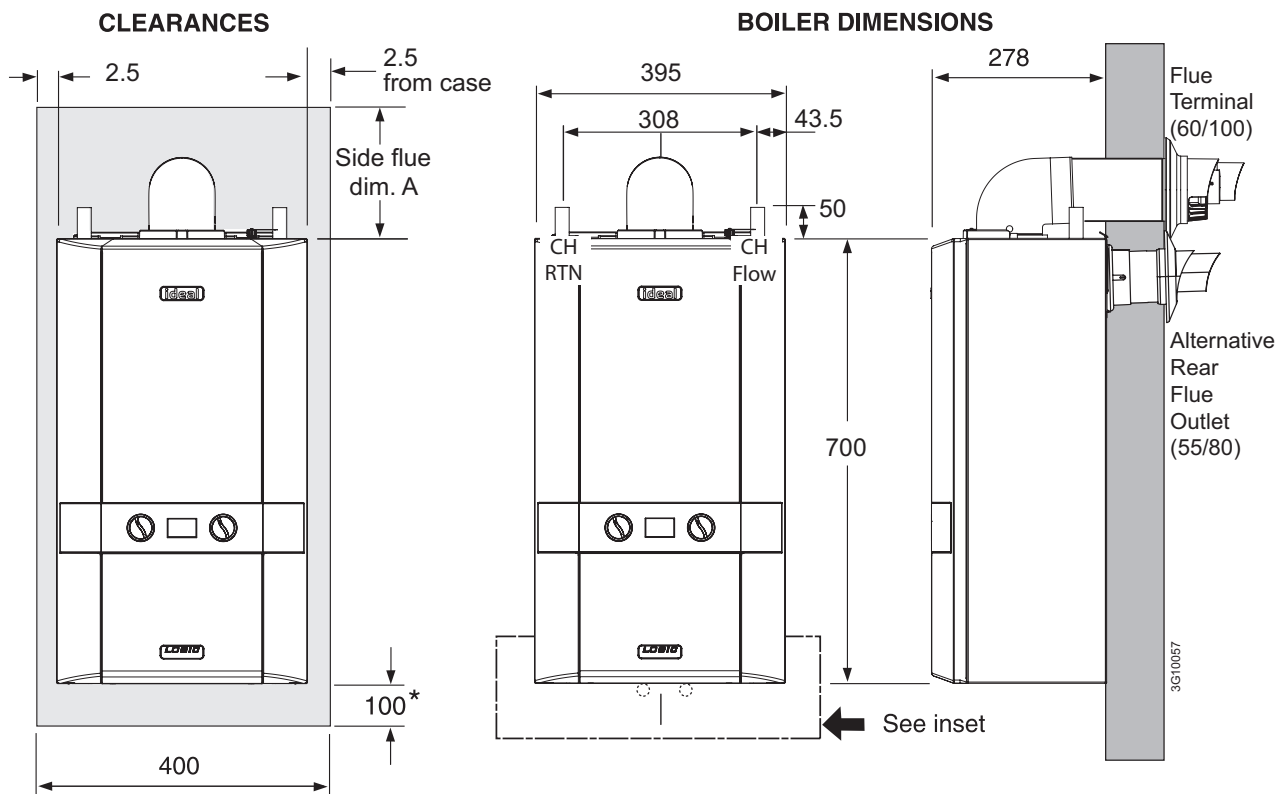

Inset: Condensate Connection and Gas Connection

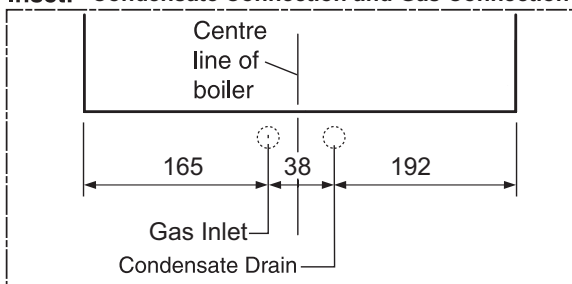

Front clearance

The minimum front clearance when built in to a cupboard is 5mm from the cupboard door but 450mm overall clearance is still required, with the cupboard door open, to allow for servicing.

* Bottom clearance

Bottom clearance after installation can be reduced to 5mm. This must be obtained with an easily removable panel, to enable the consumer to view the system pressure gauge, and to provide the 100mm clearance required for servicing.

TOP CLEARANCES

MIN. Top clearance required = 165 mm (Turret)
MIN. Top clearance required = 100mm (Rear Flue only option)

SIDE FLUE ONLY

| Horizontal length of flue from CL of boiler to outside wall | | Top clearance required (MIN.) Dim. A |
|---|-------|--------------------------------------|
| 12,15, 18, 24 | 30 | |
| 0.5 m | 0.5 m | 165 mm |
| 1.0 m | 1.0 m | 170 mm |
| 1.5 m | 1.5 m | 185 mm |
| 2.0 m | 2.0 m | 200 mm |
| 2.5 m | 2.5 m | 210 mm |
| 3.0 m | 3.0 m | 225 mm |
| 3.5 m | 3.5 m | 250 mm |
| 4.0 m | 4.0 m | 260 mm |
| 4.5 m | 4.5 m | 265 mm |
| 5.0 m | 5.0 m | 275 mm |
| 5.5 m | 5.5 m | 290 mm |
| 6.0 m | 6.0 m | 300 mm |
| 6.5 m | 6.5 m | 320 mm |
| 7.0 m | 7.0 m | 330 mm |
| 7.5 m | 7.5 m | 345 mm |
| 8.0 m | 8.0 m | 360 mm |
| 8.5m | N/A | 370 mm |
| 9.0 m | N/A | 385 mm |

GENERAL

2 OPEN VENT SYSTEM REQUIREMENTS

The system should be vented directly off the boiler flow pipe, as close to the boiler as possible. The cold feed entry should be inverted and **MUST** be positioned between the pump and the vent, and not more than 150mm (6") away from the vent connection.

Note. Combined feed and vent pipes may also be fitted.

There should be a minimum height 450mm (18") of open vent above the cistern water level. If this is not possible refer to Frame 5. The vertical distance between the highest point of the system and the feed/expansion cistern water level **MUST** not be less than 450 mm (18"). The pump must be fitted on the flow side of the boiler.

A suitable pump is a domestic circulator capable of providing a maximum 20°C temperature differential across the boiler with the whole of the heating circuit open (e.g. Grundfos UPS 15/50, 15/60 or equivalent). With the minimum flow circuit allowed by the controls the differential must not exceed 25 °C.

The vertical distance between the pump and feed/expansion cistern **MUST** comply with the pump manufacturer's minimum requirements, to avoid cavitation. Should these conditions not apply either lower the pump position or raise the cistern above the minimum requirement specified by **Ideal Stelrad Group**. The isolation valves should be fitted as close to the pump as possible.

It is recommended that an automatic air vent should be fitted to the return connection.

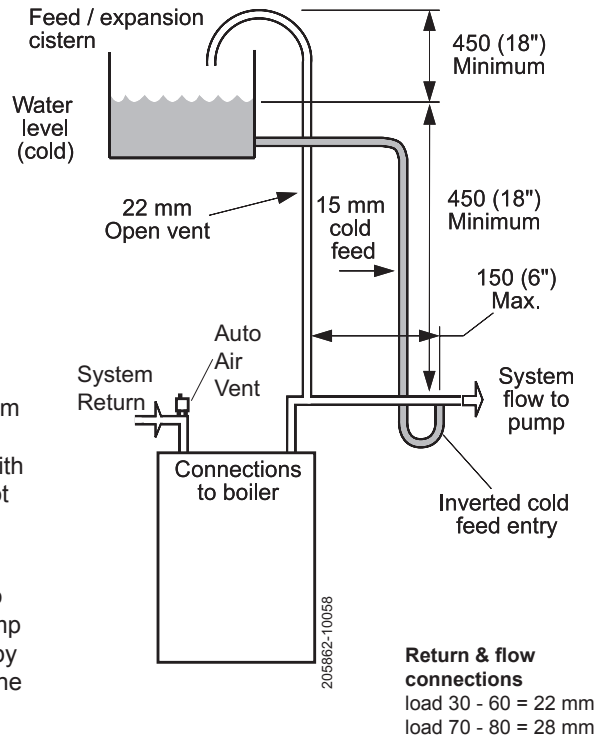

3 SCHEMATIC PIPEWORK AND SYSTEM BALANCING

The boiler does not normally need a bypass but at least some radiators on the heating circuit, of load at least 10% of the minimum boiler output, must be provided with twin lockshield valves so that this minimum heating load is always available (see footnote re. thermostatic radiator valves).

Balancing

1. Set the programmer to ON for both CH and HW. Turn the cylinder thermostat down. Close the manual or thermostatic valves on all radiators, leaving the twin lockshield valves (on the radiators referred to above) in the open position. Turn up the room thermostat and adjust these lockshield valves to give boiler flow and return temperatures not more than 20°C apart. These valves should now be left as set.
2. Open all manual or thermostatic radiator valves and adjust the lockshield valves on remaining radiators to give around 20°C temperature drop at each radiator.
3. Turn up the cylinder thermostat and adjust the cylinder balancing valve so that the cylinder achieves a maximum flow consistent with adequate flow to the radiators. Check that with only the domestic hot water loop in circuit a differential temperature of 25°C across the boiler is not exceeded.
4. Adjust room and cylinder thermostats and programmer to NORMAL settings.

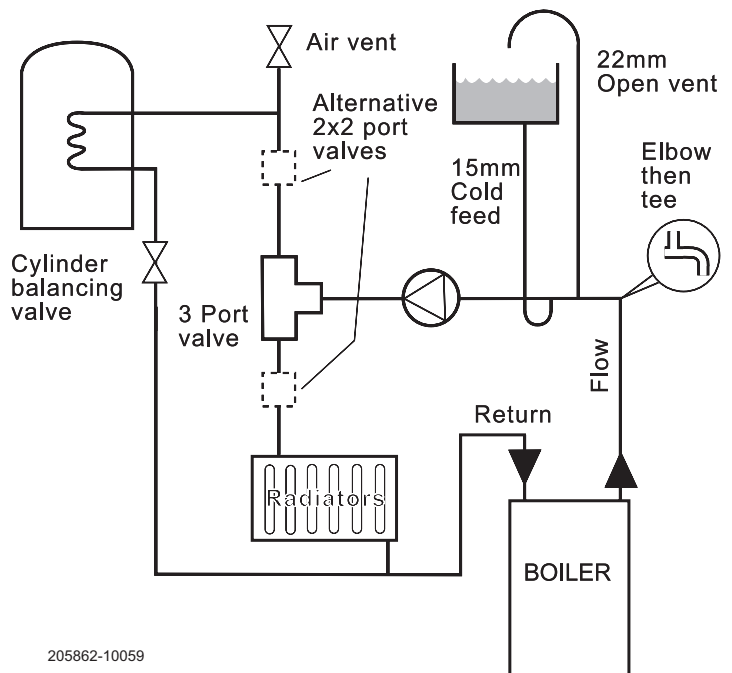

GENERAL

4 LOW HEAD AND LARGE SYSTEMS WITH EXTENSIVE PIPE RUNS - OPEN VENT

This arrangement is useful for large systems where radiators at the extremities are difficult to vent. This can lead to pumping over with conventional feed and vent arrangements.

The following conditions MUST be observed:

1. The top of the automatic air vent must be below the cold water level.
2. The static water level (cold) must be at least 200mm above the top of the horizontal flow pipe, fitted as shown. The vent connection MUST NOT be made immediately off the top of the boiler as venting is made less efficient.
3. The maximum practical length of 22mm cold feed pipe should be used in order to reduce the effective volume of hot system water expanding into the feed/expansion cistern to a minimum.

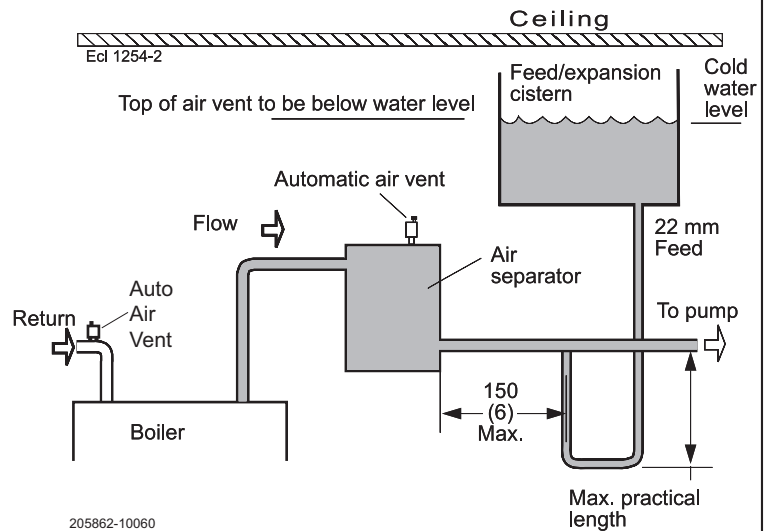

Note. The pump manufacturers' minimum requirements must be complied with.

All dimensions in mm (in.).
NB. Imperial dimensions are approximate

5 SEALED SYSTEM REQUIREMENTS

Notes.

- a. The method of filling, refilling, topping up or flushing sealed primary hot water circuit from the mains via a temporary hose connection is only allowed if acceptable to the local water authority.
- b. When installing the filling device, it must be connected as shown to fully comply with the water regulations. This may involve the fitting of an additional WRAS approval isolator valve to the mains supply.

1. General

- a. The installation must comply with the requirements of BS. 6798 and BS. 5449.
- b. The installation should be designed to work with flow temperatures of up to 82 °C.
- c. All components of the system, including the heat exchanger of the indirect cylinder, must be suitable for a working pressure of 3 bar (45lb/in²) and temperature of 110°C. Care should be taken in making all connections so that the risk of leakage is minimised.

2. Safety Valve

A spring loaded safety valve complying with the relevant requirements of BS. 6759 must be fitted in the flow pipe as close to the boiler as possible and with no intervening valve or restriction. The valve should have the following features:

- a. A non-adjustable preset lift pressure not exceeding 3bar (45lb/in²).

3. Pressure Gauge

A pressure gauge covering at least the range 0-4 bar (0-60 lb/in²) must be fitted to the system. The gauge should be easily seen from the filling point and should preferably be connected at the same point as the expansion vessel.

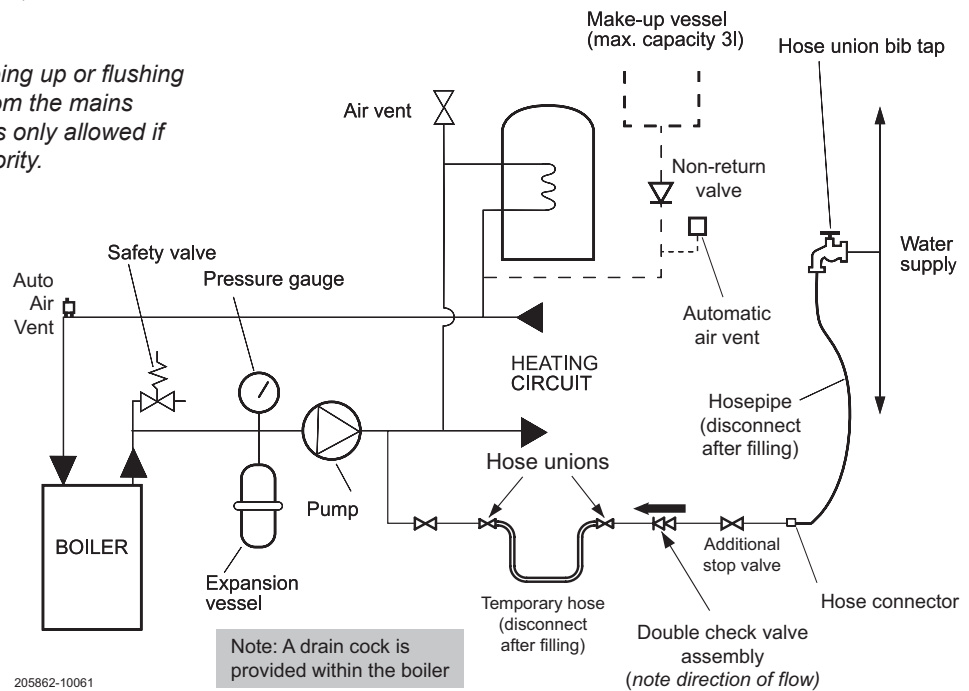

6 SEALED SYSTEM REQUIREMENTS - continued

4. Expansion Vessel

- a. A diaphragm type expansion vessel must be connected to a point close to the inlet side of the pump, the connecting pipe being not less than 15 mm (1/2" nominal) size and not incorporating valves of any sort.
- b. The vessel capacity must be adequate to accept the expansion of the system water when heated to 110°C (230°F).
- c. The charge pressure must not be less than the static water head above the vessel. The pressure attained in the system when heated to 110° C (230° F) should be at least 0.35 bar (5 lb/in²) less than the lift pressure of the safety valve.

For guidance on vessel sizing refer to the table in Frame 7.

For further details refer to BS. 5449, BS. 7074:1 and the British Gas Corporation publication 'Material and Installation Specifications for Domestic Central Heating and Hot Water'. For IE refer to the current edition of I.S.813.

5. Cylinder

The cylinder must be either of the indirect coil type or a direct cylinder fitted with an immersion calorifier which is suitable for operating on a gauge pressure of 0.35 bar (5 lb/in²) in excess of the safety valve setting. Single feed indirect cylinders are not suitable for sealed systems.

6. Make-up Water

Provision must be made for replacing water loss from the system, either:

- a. From a manually filled make-up vessel with a readily visible water level. The vessel should be mounted at least 150 mm (6") above the highest point of the system, and be connected through a non-return valve to the system, fitted at least 300 mm (12") below the make-up vessel on the return side of the domestic hot water cylinder or radiators.
- or
- b. Where access to a make-up vessel would be difficult by pre-pressurisation of the system. Refer to 'Filling', below.

7. Mains Connection

There must be no direct connection to the mains water supply or to the water storage tank supplying domestic water, even through a non-return valve, without the approval of the local water authority.

8. Filling

The system may be filled by one of the following methods:

- a. Through a cistern, used for no other purposes, via a ball valve permanently connected directly to a service pipe and/or a cold water distributing pipe.
The static head available from the cistern should be adequate to provide the desired initial system design pressure. The cold feed pipe from the cistern should

include a non-return valve and a stop valve with an automatic air vent connected between them, the stop valve being located between the system and the automatic air vent. The stop valve may remain open during normal operation of the system if automatic water make-up is required.

- b. Through a self-contained unit comprising a cistern, pressure booster pump (if required) and, if necessary, an automatic pressure reducing valve and flow restrictor. The cistern should be supplied through a temporary connection from a service pipe or cold water distributing pipe.
This unit may remain permanently connected to the heating system to provide limited automatic water make-up. Where the temporary connection is supplied from a service pipe or distributing pipe which also supplies other draw-off points at a lower level then a double check valve shall be installed upstream of the draw-off point.
- c. Through a temporary hose connection from a draw-off tap supplied from a service pipe under mains pressure. Where the mains pressure is excessive a pressure reducing valve shall be used to facilitate filling.

The following fittings shall form a permanent part of the system and shall be fitted in the order stated:

A stop valve complying with the requirements of BS. 1010, Part 2 (the hose from the draw-off tap shall be connected to this fitting).

A test cock.

A double check valve of an approved type.

- Thoroughly flush out the whole of the system with cold water, without the pump in position.
- With the pump fitted, fill and vent the system until the pressure gauge registers 1.5 bar (21.5lb/in²). Examine for leaks.
- Check the operation of the safety valve by manually raising the water pressure until the valve lifts. This should occur within ± 0.3 bar (± 4.3 lb/in²) of the preset lift pressure.
- Release water from the system until the initial system design pressure is reached.
- Light the boiler and heat the system to the maximum working temperature. Examine for leaks.
- Turn off the boiler and drain the system while still hot.
- Refill and vent the system.
- Adjust the initial pressure to the required value.

Sizing procedure for expansion vessels: The volume of the expansion vessel (litres) fitted to a sealed system shall not be less than that given by the table on the following page, multiplied by a factor of 0.8 (for flow temperatures of less than 83° C).

continued

GENERAL

7 SEALED SYSTEM REQUIREMENTS - continued

| Safety valve setting | 3.0 bar | | | 2.5 bar | | | 2.0 bar | |
|--|--------------------------------|---------|---------|---------|---------|---------|---------|---------|
| Vessel charge and initial system pressure | 0.5 bar | 1.0 bar | 1.5 bar | 0.5 bar | 1.0 bar | 1.5 bar | 0.5 bar | 1.0 bar |
| Total water content of system litres | Expansion vessel volume litres | | | | | | | |
| 25 | 2.1 | 2.7 | 3.9 | 2.3 | 3.3 | 5.9 | 2.8 | 5.0 |
| 50 | 4.2 | 5.4 | 7.8 | 4.7 | 6.7 | 11.8 | 5.6 | 10.0 |
| 75 | 6.3 | 8.2 | 11.7 | 7.0 | 10.0 | 17.7 | 8.4 | 15.0 |
| 100 | 8.3 | 10.9 | 15.6 | 9.4 | 13.4 | 23.7 | 11.3 | 20.0 |
| 125 | 10.4 | 13.6 | 19.5 | 11.7 | 16.7 | 29.6 | 14.1 | 25.0 |
| 150 | 12.5 | 16.3 | 23.4 | 14.1 | 20.1 | 35.5 | 16.9 | 30.0 |
| 175 | 14.6 | 19.1 | 27.3 | 16.4 | 23.4 | 41.4 | 19.7 | 35.0 |
| 200 | 16.7 | 21.8 | 31.2 | 18.8 | 26.8 | 47.4 | 22.6 | 40.0 |
| 225 | 18.7 | 24.5 | 35.1 | 21.1 | 30.1 | 53.3 | 25.4 | 45.0 |
| 250 | 20.8 | 27.2 | 39.0 | 23.5 | 33.5 | 59.2 | 28.2 | 50.0 |
| 275 | 22.9 | 30.0 | 42.9 | 25.8 | 36.8 | 65.1 | 31.0 | 55.0 |
| 300 | 25.0 | 32.7 | 46.8 | 28.2 | 40.2 | 71.1 | 33.9 | 60.0 |
| Multiplying factors for other system volumes | 0.0833 | 0.109 | 0.156 | 0.094 | 0.134 | 0.237 | 0.113 | 0.20 |

8 SYSTEM BALANCING

The boiler does not normally need a bypass but at least some radiators on the heating circuit, of load of at least 10% of the minimum boiler output, must be provided with twin lockshield valves so that this minimum heating load is always available. See note regarding thermostatic radiator valves on page 9.

Note. *Systems incorporating zone valves which could completely cut off the flow through the system must also include a bypass.*

BALANCING

- Set the programmer to ON.
Close the manual or thermostatic valves on all radiators, leaving the twin lockshield valves (on the radiators referred to above) in the OPEN position.
Turn up the room thermostat and adjust the lockshield valve to give an uninterrupted flow through the radiator.
These valves should now be left as set.
- Open all manual or thermostatic radiator valves and adjust the lockshield valves on the remaining radiators, to give around 20°C temperature drop at each radiator.
- Adjust the room thermostat and programmer to NORMAL settings.

9 WATER TREATMENT

CENTRAL HEATING

The Logic Heat range of boilers have an ALUMINIUM alloy heat exchanger.

IMPORTANT.

The application of any other treatment to this product may render the guarantee of Ideal Stelrad Group Invalid.

Ideal Stelrad Group recommend Water Treatment in accordance with the Benchmark Guidance Notes on Water Treatment in Central Heating Systems.

If water treatment is used **Ideal Stelrad Group** recommend only the use of Scalemaster Gold 100, FERNOX, MBI or SENTINEL X100 inhibitors and associated water treatment products, which must be used in accordance with the manufacturers' instructions.

Notes.

- It is most important that the correct concentration of the water treatment products is maintained in accordance with the manufacturers' instructions.*
- If the boiler is installed in an existing system any unsuitable additives MUST be removed by thorough cleansing. BS 7593:2006 details the steps necessary to clean a domestic heating system.*
- In hard water areas, treatment to prevent lime scale may be necessary - however the use of artificially softened water is NOT permitted.*
- Under no circumstances should the boiler be fired before the system has been thoroughly flushed.*

For further information contact:

Fernox Manufacturing Co. Ltd
Cookson Electronics
Forsyth Road, Sheerwater, Woking
Surrey GU21 5RZ
+44 (0) 1799 521133

Sentinel Performance Solutions
The Heath Business & Technical Park
Runcorn, Cheshire WA7 4QX
Tel: 0800 389 4670
www.sentinel-solutions.net

Scalemaster Water Treatment Products
Emerald Way, Stone, Staffordshire
ST15 0SR
Tel:01785 811636

Calmag Ltd.
Unit 4-6, Crown Works
Bradford Road, Sandbeds, Keighley
West Yorkshire BD20 5LN
Tel: +44 (0) 1535 210 320

GENERAL

10 BOILER ASSEMBLY - Exploded View

Note that item numbers are linked to the spares list

| | | | | | |
|-----|----------------------|-----|-------------------------------------|-----|-----------------------|
| 103 | HEAT EXCHANGER DRAIN | 223 | FLUE MANIFOLD | 306 | ELECTRODE IGNITION |
| 104 | FLOW SENSOR | 224 | FLUE MANIFOLD TOP | 307 | ELECTRODE DETECTION |
| 105 | PIPE - FLOW | 225 | FLUE MANIFOLD - TOP SEALING CAP | 308 | IGNITOR UNIT |
| 106 | PIPE - RETURN | 226 | FLUE MANIFOLD - REAR SEALING CAP | 313 | IGNITION LEAD |
| 203 | GAS COCK | 227 | CLAMP RETAINING FLUE TURRET | 314 | CONTROL BOX LENS |
| 204 | PIPE - GAS INLET | 228 | HOSE CONDENSATE INTERNAL | 324 | CONTROLS BOX LID |
| 205 | GAS VALVE | 229 | SIPHON TRAP | 325 | CONTROL BOX FRONT |
| 206 | PIPE - GAS INJECTOR | 230 | SIPHON TRAP CAP & SEAL | 401 | HEAT ENGINE |
| 211 | INJECTOR ASSEMBLY | 231 | CONDENSATE OUTLET CONNECTION | 503 | WALL MOUNTING BRACKET |
| 214 | VENTURI | 233 | FLUE SENSING NIPPLE | 504 | FRONT PANEL |
| 215 | FAN | 301 | CONTROLS BOX FIXINGS HINGE & SPRING | 505 | FASCIA |
| 217 | BURNER | 302 | PRIMARY PCB* | 506 | BRACKET - GAS VALVE |
| 218 | GASKET - BURNER | 303 | CUI BOARD | 512 | INFILL FRONT PANEL |
| 219 | SUMP CLEAN OUT COVER | 304 | CONTROL THERMISTOR (RETURN) | | |

* Note that production boiler PCBs are factory pre-set to operate for boiler range and output, but when ordering Primary PCB as a spare, an additional Boiler Chip Card (BCC) MUST also be purchased for your specific boiler range and output.

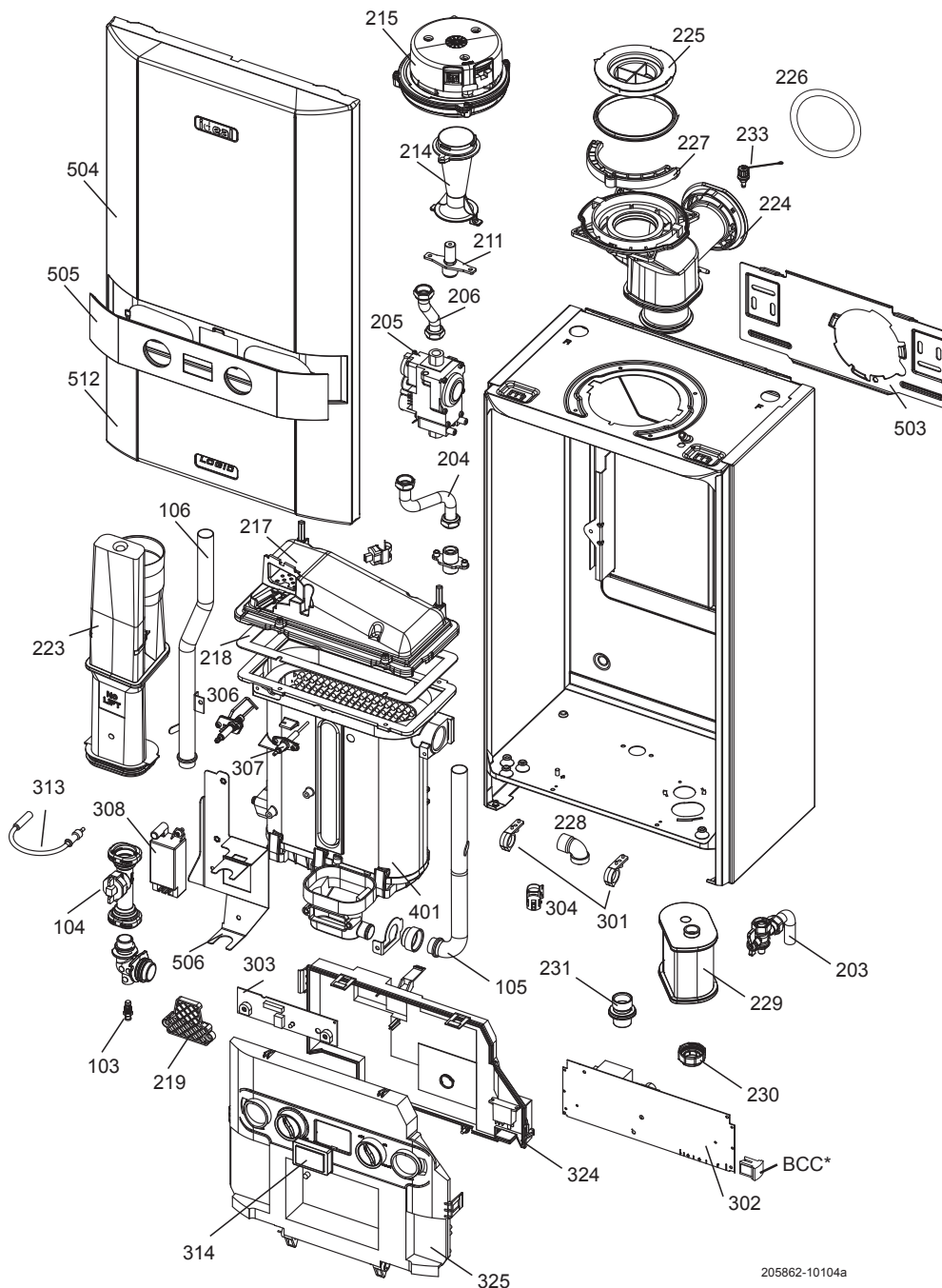

205862-10104a

11 UNPACKING

The boiler is supplied fully assembled together with a flue pack (Pack B)

Unpack and check the contents.

Pack A Contents

- A Boiler
- B Hardware Pack Box
- C Wall Mounting Plate
- D These Installation/Users Instructions
- E Wall Mounting Template (located on internal protective packaging)
- F Boiler Guarantee & Registration Pack

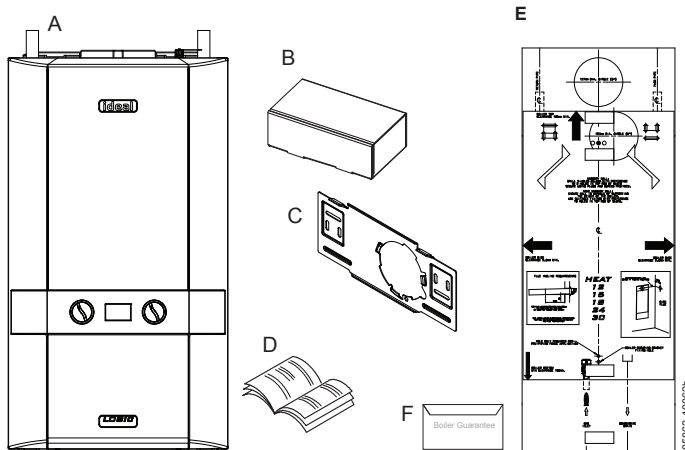

HARDWARE PACK CONTENTS

Gas Valve Pack

- 1. Pipe - Gas Inlet
- 2. Washer - Gas (blue)
- 3. Gas Cock

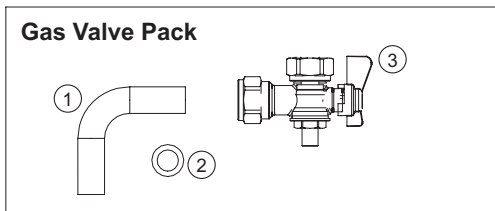

Accessory Pack

- 1. Screw (x3)
- 2. Wallplug (x3)

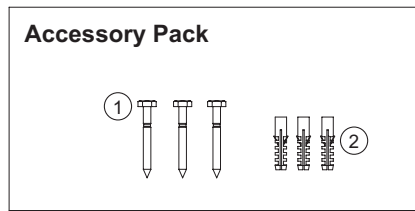

205862-10063

Pack B Contents Rear Flue Outlet Kit (55/80)

- A Plastic Connector
- B Flue Terminal
- C Rubber terminal wall seal
- D 2 x Self Tapping Screws
- E Sealing Tape
- F Cutting Aid

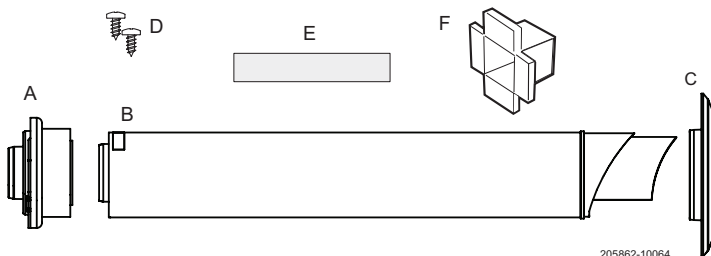

205862-10064

Pack B Contents Non-Telescopic (60/100)

- A Flue terminal
- B Flue turret
- C Rubber terminal wall seal
- D Cutting Aid

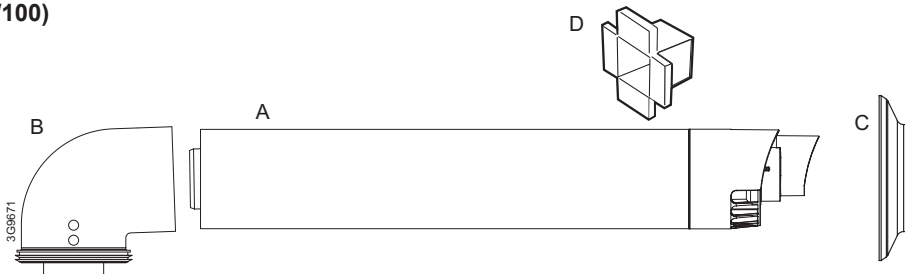

Pack B Contents Telescopic (60/100)

- A Telescopic flue terminal
- B Flue turret
- C Rubber terminal wall seal
- D Screw
- E Sealing Tape

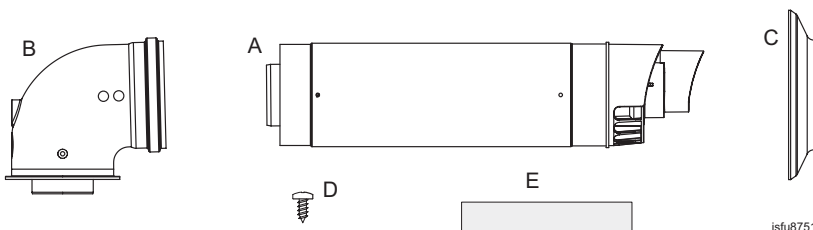

isfu8751d

INSTALLATION

12 FRONT PANEL REMOVAL

1. Loosen the 2 screws retaining the front panel.
2. Pull the two spring clips downwards to disengage.
3. Pull the front panel forward and upwards to remove.

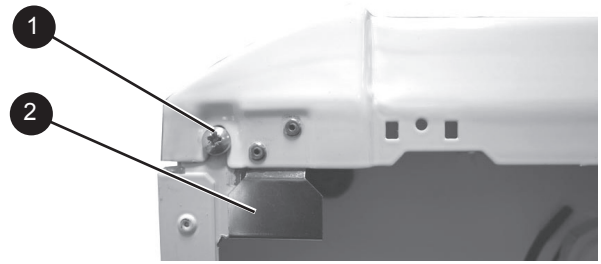

13 DETERMINING THE FLUE LENGTH AND FLUE PACKS REQUIRED (TURRET & REAR FLUE OPTION)

IMPORTANT. The boiler MUST be installed in a vertical position

FLUE KITS

Pack B - rear flue outlet kit (55/80) (supplied as standard)

Pack B - non-telescopic (600mm & 1000mm options available)

Pack B - optional telescopic

Pack D - optional extension kit for side flue or rear flue outlet.

Concentric Flue Retaining Kit - Optional Kit for mechanical fixing of flue joints

Finishing Kit - Supplied as an optional extra.

Refer to 'Flue Extension Ducts'

Note. MAXIMUM FLUE LENGTHS:

12,15,18,24 - 9M (HORIZONTAL FLUE)

30 - 8M (HORIZONTAL FLUE)

12,15,18,24,30 - 7.5M (ROOF FLUE)

12,15,18,24,30 - 442MM (REAR FLUE OUTLET KIT (55/80))

12,15,18,24,30 - 5M PRIMARY AND 17M SECONDARY IS A TYPICAL MAX.

FLUE LENGTH. (For alternative details refer to Powered Vertical Instructions)

90° ELBOW KIT 60/100 (EQUIVALENT FLUE LENGTH RESISTANCE = 1M)

45° ELBOW KIT 60/100 (EQUIVALENT FLUE LENGTH RESISTANCE = 0.6M)

MINIMUM HORIZONTAL FLUE LENGTHS - TELESCOPIC TERMINAL = 150MM

(Centre Line of turret to outside of wall terminal) - ONE PIECE TERMINAL = 115MM

- REAR FLUE OUTLET KIT (55/80) TERMINAL = 115MM (WALL THICKNESS)

Dimension X - Wall thickness.

Dimension L - Wall thickness plus boiler spacing.

Dimension S - Optional stand-off frame depth 45mm.

REAR FLUE (TURRET)

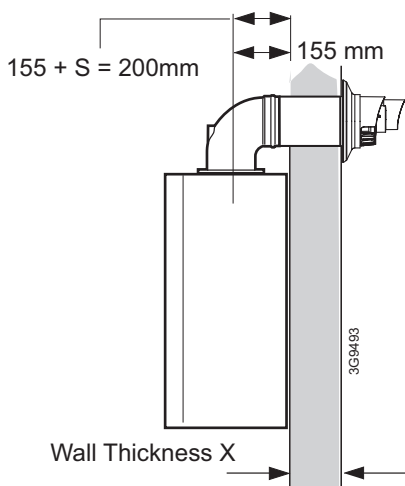

SIDE FLUE

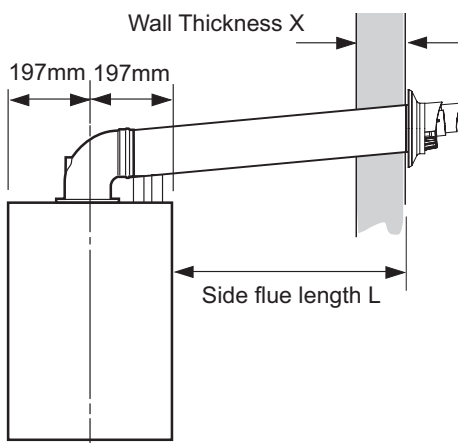

REAR FLUE OUTLET KIT (55/80)

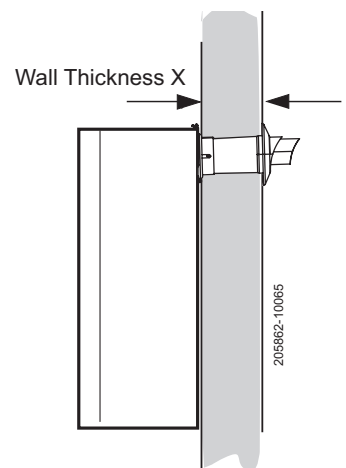

continued

INSTALLATION

14 DETERMINING THE FLUE LENGTH AND FLUE PACKS REQUIRED CONT'D

Notes.

1. It is recommended that a support bracket is fitted for every 1 metre of extension pipe used and a bracket should be used at every joint, to ensure pipes are held at the correct angle.

If a slip joint coupling is to be used then a bracket should be used to secure the collar.
2. When extension 'D' packs are used the flue duct MUST be inclined at 1.5 degrees to the horizontal to allow condensate to drain back into the boiler and out through the condensate drain.
3. If the B pack, or telescopic B pack only are used, they may be mounted horizontally. The 1.5 degrees is taken care of by the inclination of the flue within the air pipe.
4. Only use water as a lubricant during assembly.

NON - TELESCOPIC FLUE (600mm long Kit)

| Total Flue length dimension (measuring from CL of turret to outside wall) | | Flue | |
|--|----------------------|----------------------|-----------------|
| Rear flue dim. X+155 | Side flue dim. L+197 | Extra packs required | Boiler Size |
| Up to 640 mm | Up to 640 mm | none | 12,15,18,24,30 |
| Up to 1590 mm | Up to 1590 mm | Pack D - 1 off | 12,15,18,24,30 |
| Up to 2540 mm | Up to 2540 mm | Pack D - 2 off | 12,15,18,24,30 |
| Up to 3490 mm | Up to 3490 mm | Pack D - 3 off | 12,15,18,24,30 |
| Up to 4440 mm | Up to 4440 mm | Pack D - 4 off | 12,15,18,24,30 |
| Up to 5390 mm | Up to 5390 mm | Pack D - 5 off | 12,15,18,24,30 |
| Up to 6340 mm | Up to 6340 mm | Pack D - 6 off | 12,15,18,24,30 |
| Up to 7290 mm | Up to 7290 mm | Pack D - 7 off | 12,15,18,24,30 |
| Up to 8240 mm | Up to 8240 mm | Pack D - 8 off | 12,15,18,24,30* |
| Up to 9000 mm | Up to 9000 mm | Pack D - 9 off | 12,15,18,24 |

* Logic Heat 30 is capable of 8m flue only

TELESCOPIC FLUE

| Total Flue length dimension (measuring from CL of turret to outside wall) | | Flue | |
|--|----------------------|----------------------|-----------------|
| Rear flue dim. X+155 | Side flue dim. L+197 | Extra packs required | Boiler Size |
| Up to 575 mm | Up to 575 mm | none | 12,15,18,24,30 |
| Up to 1525 mm | Up to 1525 mm | Pack D - 1 off | 12,15,18,24,30 |
| Up to 2475 mm | Up to 2475 mm | Pack D - 2 off | 12,15,18,24,30 |
| Up to 3425 mm | Up to 3425 mm | Pack D - 3 off | 12,15,18,24,30 |
| Up to 4375 mm | Up to 4375 mm | Pack D - 4 off | 12,15,18,24,30 |
| Up to 5325 mm | Up to 5325 mm | Pack D - 5 off | 12,15,18,24,30 |
| Up to 6275 mm | Up to 6275 mm | Pack D - 6 off | 12,15,18,24,30 |
| Up to 7225 mm | Up to 7225 mm | Pack D - 7 off | 12,15,18,24,30 |
| Up to 8175 mm | Up to 8175 mm | Pack D - 8 off | 12,15,18,24,30* |
| Up to 9000 mm | Up to 9000 mm | Pack D - 9 off | 12,15,18,24 |

* Logic Heat 30 is capable of 8m flue only

15 WALL MOUNTING TEMPLATE

The wall mounting template is located on the internal protective packaging.

Note. The template shows the positions of the fixing holes and the rear flue hole centre for both turret rear flue and rear flue option kit. Care MUST be taken to ensure the correct holes are drilled.

1. Tape template into the selected position. Ensure squareness by hanging a plumbline as shown.
2. If fitting a side flue extend the flue centre line onto the side wall and measure in 155mm for standard installation.
3. Mark onto the wall the following:
 - a. The wall mounting plate screw positions (choose one from each group).
 - b. The position of the flue duct hole (see diagram below).
 - c. The position of the boiler bottom fixing screw.

Note. Mark the centre of the hole as well as the circumference.

4. Remove the template from the wall.

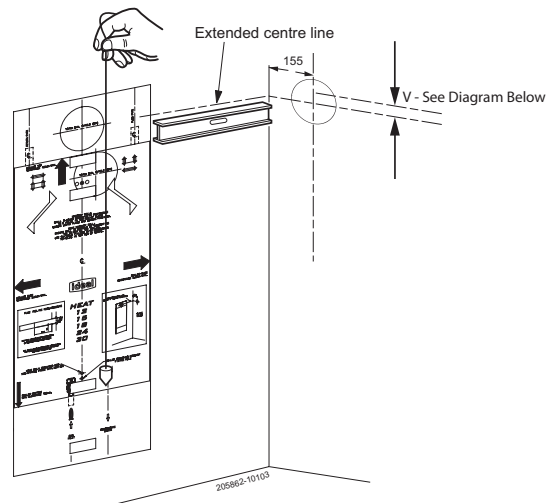

See wall mounting template

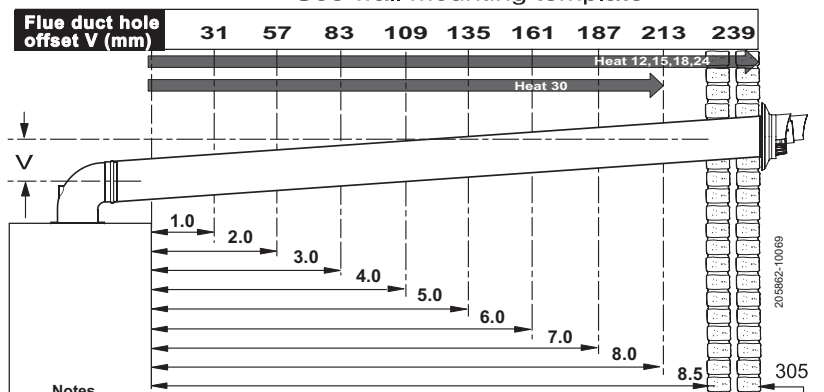

Notes.

1. If the wall thickness is greater than 305mm then dimension "H" must be reduced by the same amount and the offset may be adjusted accordingly.
2. For flue lengths greater than 600mm the flue must be inclined by 26mm per 1000mm flue length.

* "H" = Distance in metres from side of the boiler to the side wall

INSTALLATION

16 PREPARING THE WALL

IMPORTANT.

Ensure that, during the cutting operation, masonry falling outside of the building does not cause damage or personal injury.

1. Cut the rear flue hole (preferably with a 5" core boring tool), ensuring that the hole is square to the wall.
Both wall faces immediately around the cut hole should be flat.
2. Drill 3 holes with a 7.5mm / 8mm masonry drill and insert the plastic plugs, provided, for the wall mounting plate and the boiler bottom retaining bracket.
3. Locate 2 No.14 x 50mm screws in the wall mounting plate (one at each side, in any of the 3 holes provided at each side) and screw home.

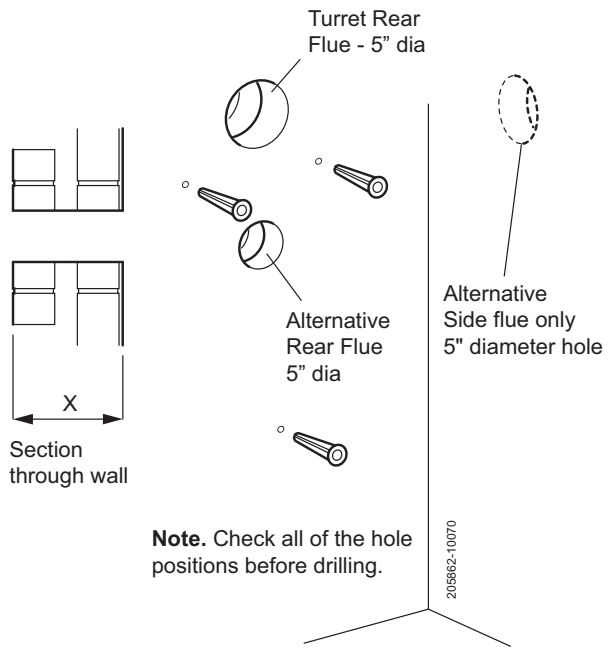

17 TURRET FLUE ASSEMBLY - Exploded View

An optional flue duct extension kit is required for wall thicknesses greater than :

- Side** 378mm
- Rear** 420mm

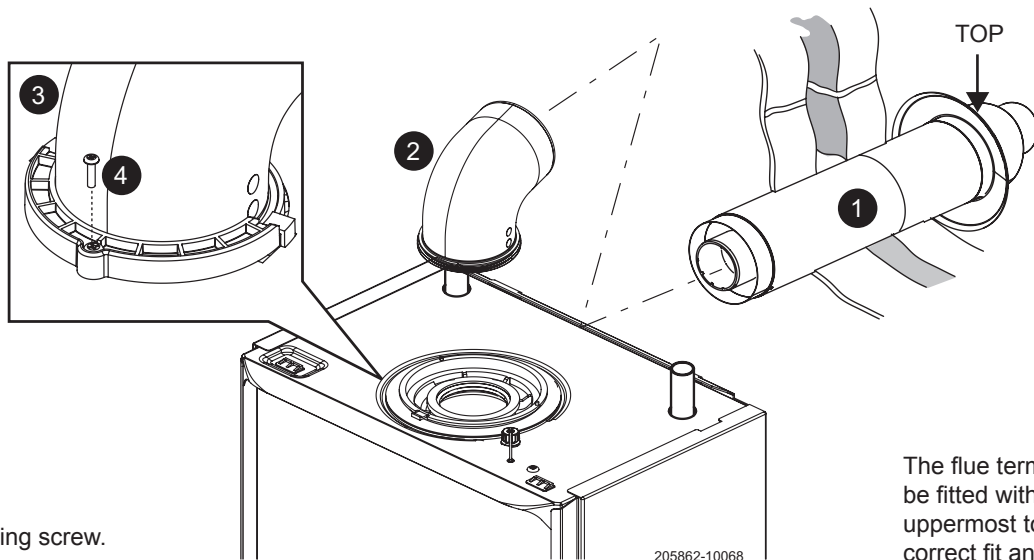

LEGEND

1. Duct assembly.
2. Flue turret.
3. Turret clamp.
4. Turret clamp fixing screw.

The flue terminal **MUST** be fitted with the 'TOP' uppermost to allow the correct fit and use of the High Level Flue Outlet.

Telescopic B Pack shown

FLUE OUTLET

INSTALLATION

18 TERMINAL WALL SEAL ASSEMBLY / POSITIONING

Prior to fitting the flue, the rubber terminal wall seal provided in the flue pack **MUST** be fitted to the flue terminal as shown below in Figure 1.

Once the flue is installed it is **IMPORTANT** that the rubber terminal wall seal is pressed against the outside wall to create an adequate seal between the flue and wall as shown in Figure 2.

FIGURE 1

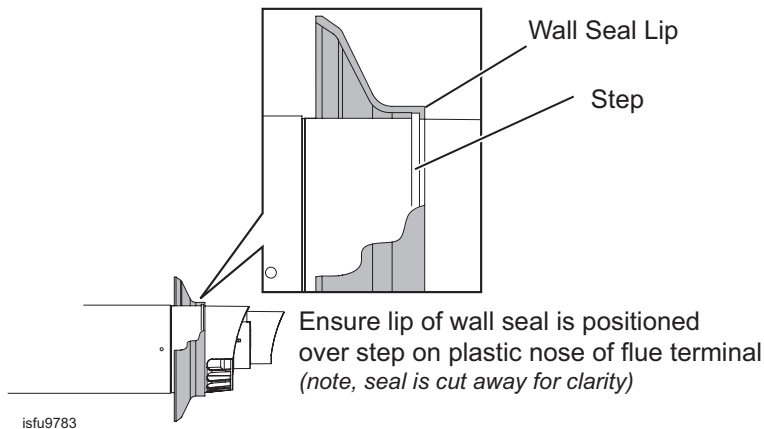
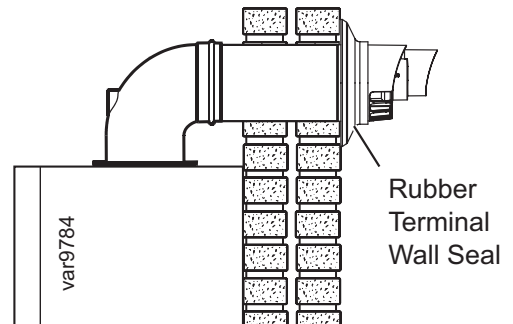

FIGURE 2



19 SETTING THE FLUE - REAR

NON TELESCOPIC FLUE - Wall thickness of 115mm to 485mm

Notes.

- a. If using the extension ducts go to Frame 21.
- b. If the stand-off frame is used it is essential to add 45mm to 'X' the measured wall thickness when marking the flue (this will allow for the fitted frame).

1. Measure and note wall thickness X. Refer to Frame 13.
2. Add 90mm to dimension X and, measuring from the ring, cut the outer tube only.
3. To ensure the tube is cut square, mark the flue all the way around.
4. Cut the inner tube to a length 20mm longer to aid engagement, using the cutting aid provided.

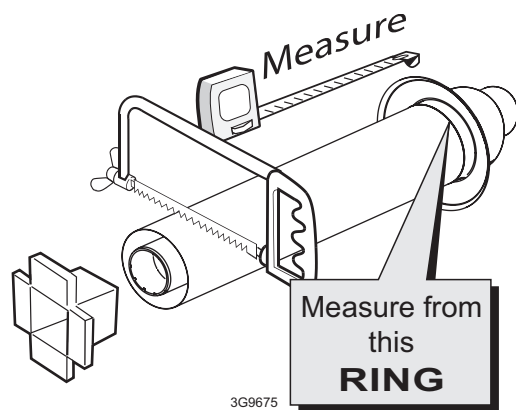

TELESCOPIC FLUE - Wall thickness of 195mm to 420mm

Notes.

- a. If using the extension ducts go to Frame 21.
- b. For shorter flue requirements use non telescopic B Pack.
- c. If the stand-off frame is used it is essential to add 45mm to 'X' the measured wall thickness when marking the flue (this will allow for the fitted frame).

1. Measure and note wall thickness X. Refer to Frame 13.
2. Add 75mm to dimension X and set telescopic flue length as indicated in drawing.
3. Using a 3.5mm drill bit, drill one hole in outer air duct taking care not to pierce plastic inner flue.
4. Fix to length using self tappers provided.
5. Seal outer air duct using the tape provided.

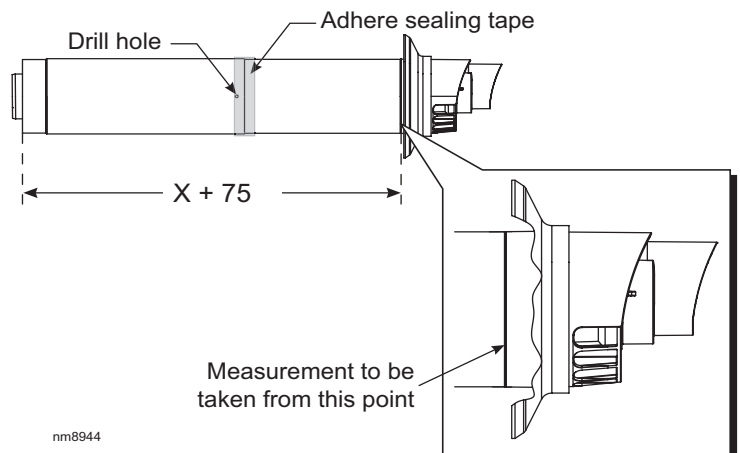

INSTALLATION

20 SETTING THE FLUE - SIDE

Wall thicknesses of 148 to 378mm

NON TELESCOPIC FLUE - Wall thickness of 115mm to 440mm

Notes.

If using the extension ducts go to Frame 21.

1. Measure and note side flue length L. Refer to Frame 13.
2. Add 125mm to dimension L and, measuring from the ring, cut the outer tube only.
3. To ensure the tube is cut square, mark the flue all the way around.
4. Cut the inner tube to a length 20mm longer to aid engagement, using the cutting aid provided

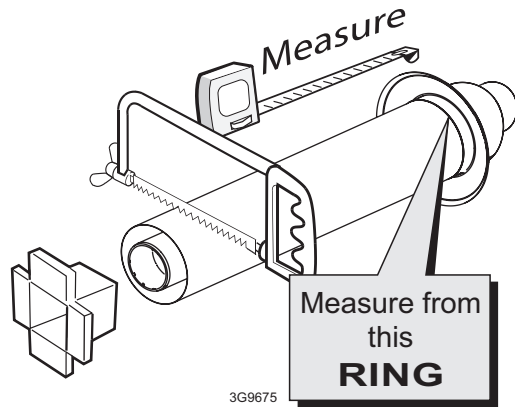

3G9675

TELESCOPIC FLUE - Wall thickness of 150mm to 375mm

Notes.

- a. If using the extension ducts go to Frame 21.
- b. For shorter flue requirements use non telescopic B Pack.

1. Measure and note wall thickness X. Refer to Frame 13.
2. Measure distance from side of boiler to inside of wall and add to wall thickness $X=L$. Refer to Frame 13.
3. Add 115mm to dimension L and set telescopic flue length as indicated in drawing.
4. Using a 3.5mm drill bit, drill one hole in outer air duct taking care not to pierce plastic inner flue.
5. Fix to length using self tappers provided.
6. Seal outer air duct using the tape provided.

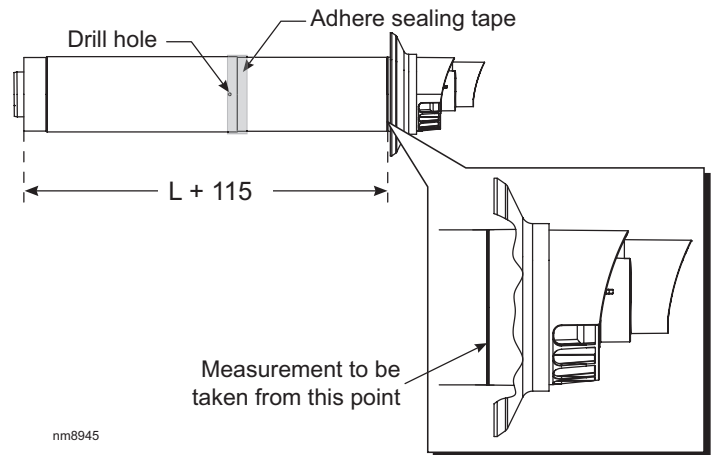

nm8945

21 FLUE EXTENSION DUCTS - For total flue lengths greater than 575mm

Pack D Flue extension duct kit contents

Extension duct & clamp
1.0m (39") long

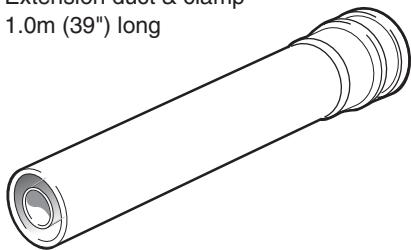

nm8732

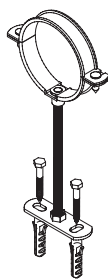

Flue duct support

Flue support cutting aid
(shown folded up)

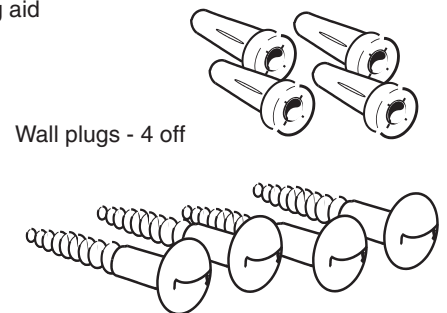
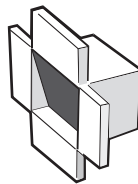

Wall plugs - 4 off

No. 10 x 2" wood screw - 4 off

INSTALLATION

22 FLUE EXTENSION DUCTS - continued

Use a maximum of 9m extended flue ONLY (12,15,18,24)

Use a maximum of 8m extended flue ONLY (30)

General arrangement

1. A **maximum** number of extension ducts are possible for each boiler output with one suitably cut.
 - 9 extension ducts for 12, 15, 18 & 24
 - 8 extension ducts for 30Refer to Frame 14 for lengths
2. Flue extensions of greater length than 1m should be supported with the bracket provided, suitably adjusted. Refer to Frames 21 and 33.
3. **Only use water as a lubricant during assembly. Do not use mineral based oils.**

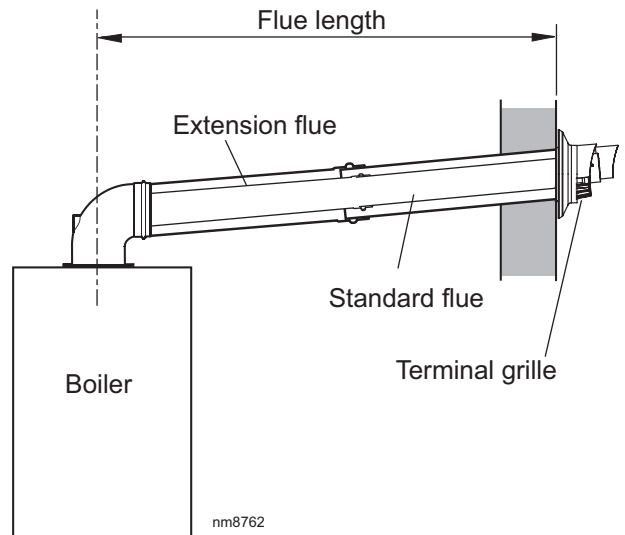

23 FITTING THE KIT

If the telescopic flue terminal is used it is not always necessary to cut an extension pack.

1. Measure the total flue length 'L' from the centre of the boiler outlet to the outside wall.
2. Subtract 65mm from this dimension.
3. Subtract 950mm for each 'D' pack to be used.
4. If the remainder Y is 300mm - 500mm this can be taken up by the adjustment in the telescopic flue.
5. If the remainder Y is 500mm - 950mm it will be necessary to use a further 'D' pack cut to 400mm.
6. If the remainder Y is less than 300mm, shorten the previous 'D' pack to suit required length and adjust the telescopic terminal.
7. Measure and mark the length on the flue, to ensure a square cut mark the flue all the way around and cut to length.

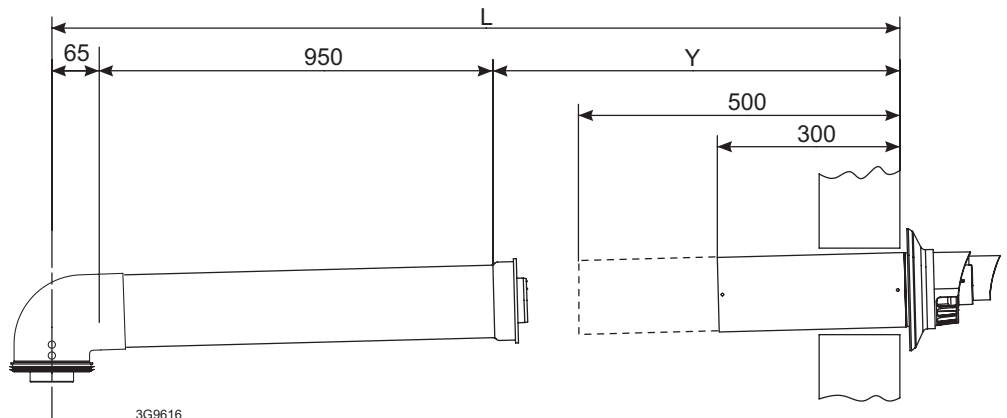

24 FITTING THE WALL MOUNTING PLATE (TURRET OPTION)

Screw the wall mounting plate to the wall using 2 wall plugs (previously fitted) with the 2 screws provided.

Choose one of the 2 sets of slots in left and right bank. Ensuring that at least one of the screws is fitted into a top slot.

Example of fixing

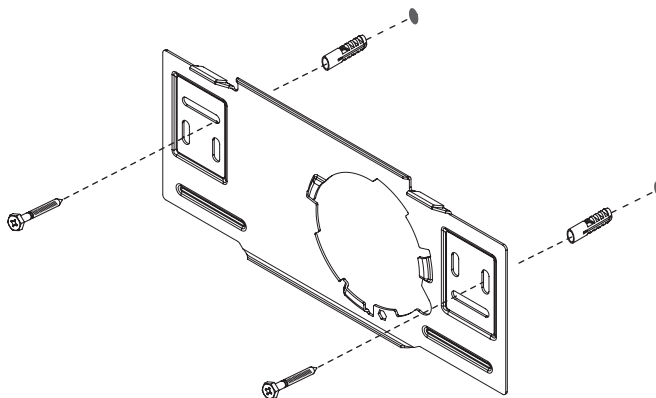

205862-10084

25 MOUNTING THE BOILER (TURRET OPTION)

1. Remove the top flue plastic blanking disc and retain the plastic horseshoe fixing and screw.
2. Lift the boiler onto the wall mounting plate (refer to the Introduction section for safe handling advice), locating it over the two tabs.
3. Screw the boiler bottom retaining bracket to the wall with the screw provided.

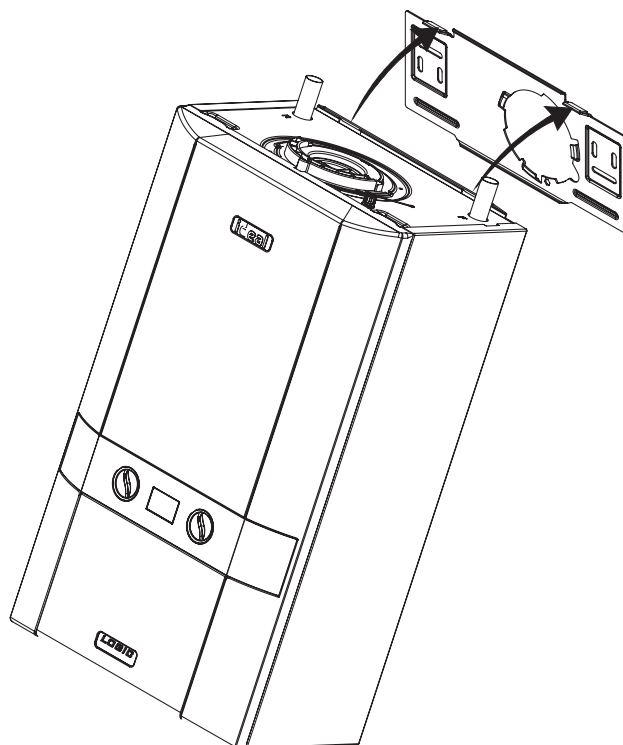

205862-10086

INSTALLATION

26 CONNECTING THE FLUE TO THE BOILER TURRET

Notes.

- Before fitting the flue turret remove the retaining clamp and the top flue blanking disk then fill the condensate trap within the boiler by pouring a cupful of water into the flue outlet (shown below). Take care to ensure that the water is only poured into the flue outlet, and does not spill into the boiler casing.
- During assembly check that flue seals do not become dislodged.

NOTE. SIDE FLUE

Select flue orientation before inserting turret into boiler flue manifold.

DO NOT twist the turret once inserted.

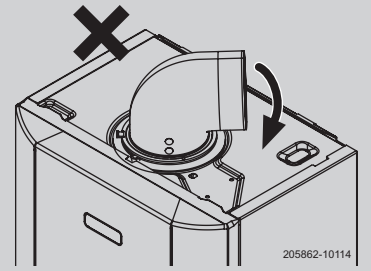

1. Ensure front panel is removed. Refer to Frame 12.
2. Locate the flue into the turret.
3. Insert the flue assembly through the prepared hole in the wall. Push through and pull back to seal against outside wall face.
4. Ensure rubber flue seal is present & fully engaged into plastic top flue manifold then locate the flue turret into the flue manifold and secure by applying downward pressure.
5. Engage the clamp in its slide mechanism and push it horizontally backwards
6. Fit the previously removed fixing screw.

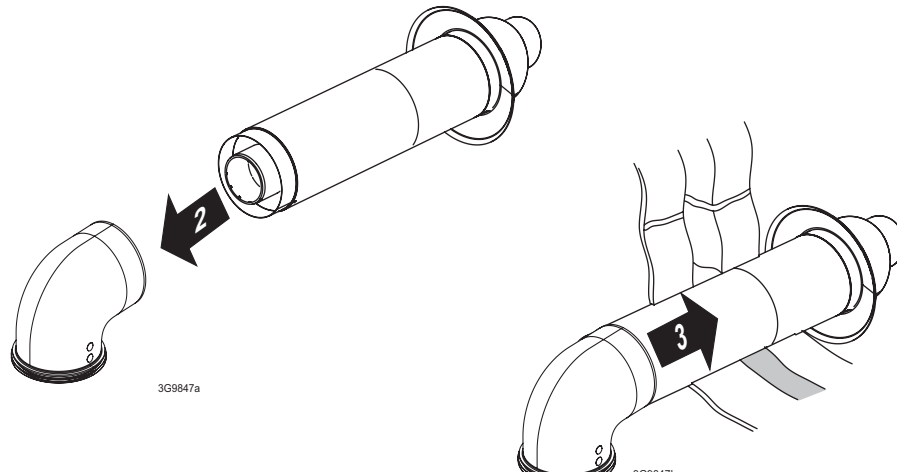

Note - Flues over 1 metre long

It is recommended that a support bracket is fitted for every 1 metre of extension pipe used and a bracket should be used at every joint, to ensure pipes are held at the correct angle.

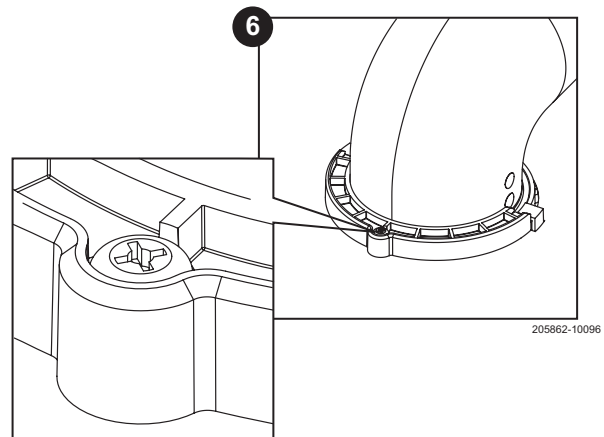
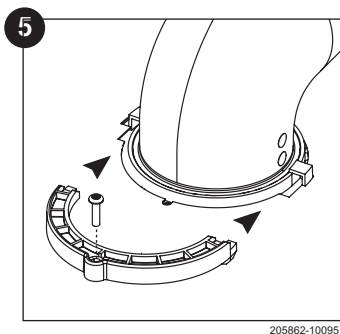
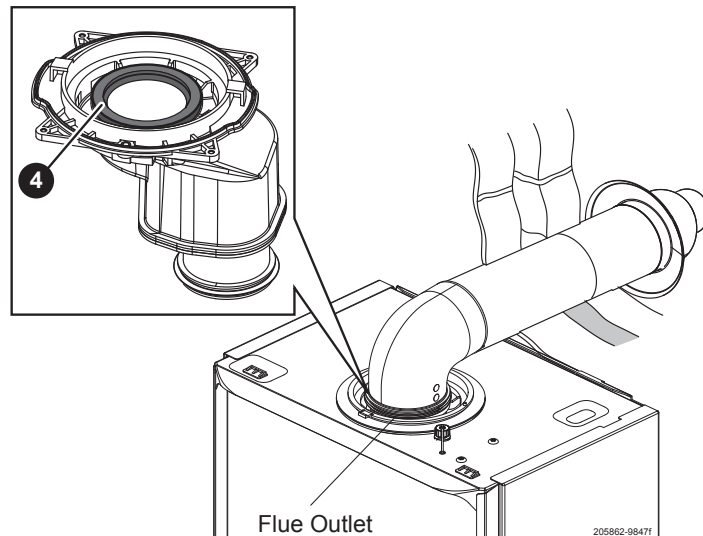

INSTALLATION

27 REAR FLUE OUTLET KIT (55/80) ASSEMBLY - EXPLODED VIEW

LEGEND

1. Duct Assembly
2. Plastic Connector
3. Wall Mounting Plate

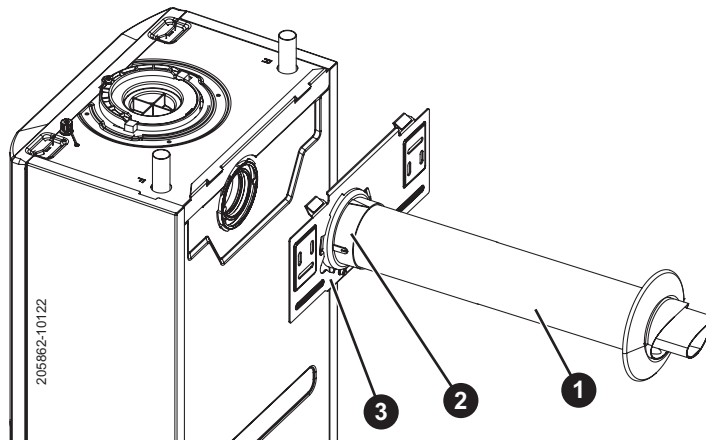

28 TERMINAL WALL SEAL ASSEMBLY/POSITIONING

Prior to fitting the flue, the rubber terminal wall seal provided in the flue pack **MUST** be fitted to the flue terminal as shown below in Figure 1.

FIGURE 1

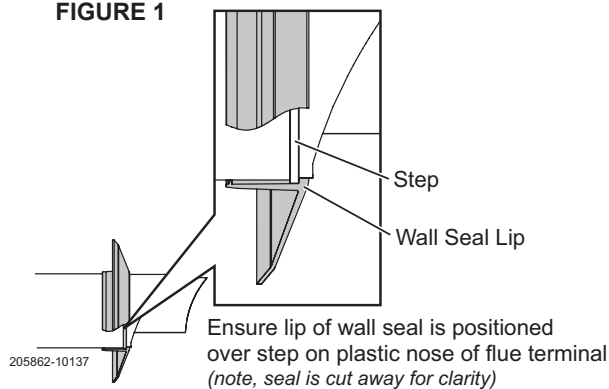

Once the flue is installed it is **IMPORTANT** that the rubber terminal wall seal is pressed against the outside wall to create an adequate seal between the flue and wall as shown in Figure 2.

FIGURE 2

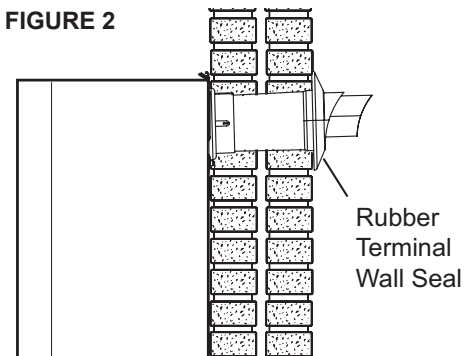

29 SETTING THE REAR FLUE LENGTH - WALL THICKNESS OF 115MM TO 442 MM

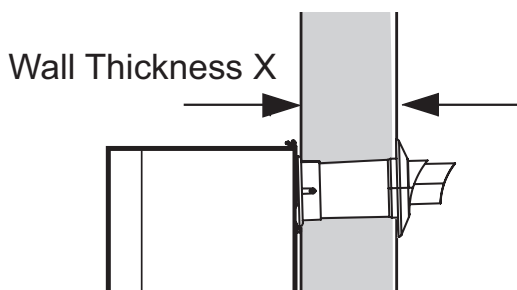

1. Measure and note wall thickness X. Refer to Frame 13.
2. Add 8mm to dimension X and, measuring from the ring, cut the outer tube only.
3. To ensure the tube is cut square, mark the flue all the way around.
4. Cut the inner tube to a length 10mm longer to aid engagement, using the cutting aid provided.

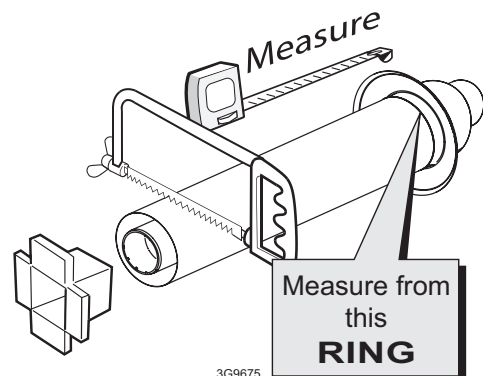

Note. If the stand-off frame is used, it is essential to add 45mm to 'X' the measured wall thickness when marking the flue (this will allow for the fitted frame)

INSTALLATION

30 FITTING THE WALL PLATE/REAR FLUE TERMINAL ASSEMBLY

1. Ensure the rubber terminal wall seal is fitted to the terminal. Refer to Frame 28.
2. Insert the previously cut to length terminal assembly into the plastic connector.
3. Line up the mark on the top of the plastic connector with the top of the terminal (marked with a label).
4. Drill 2 - 3.5mm dia holes through each side of the plastic connector and the air duct and fit the two self tapping screws (provided) to retain the duct terminal assembly to the plastic connector.
5. Seal the joint between the plastic connector and the terminal air duct with the tape provided.
6. Push the terminal assembly through the prepared hole in the wall until the rubber seal clears the outside wall. Rest the assembly in the hole while fitting the wall mounting plate.
7. Screw the wall mounting plate to the wall using 2 wall plugs (previously fitted) with the 2 screws provided. Choose one of the 2 sets of slots in the left and right bank. Ensure that at least one of the screws is fitted into a top slot.
8. Pull the flue assembly back through the wall mounting plate to seal against the outside wall face and ensure the 3 locating tabs are pulled through the wall mounting plate slots.
9. Turn the plastic connector clockwise to lock the connector into the wall plate.
10. Retain with the M5 screws provided.

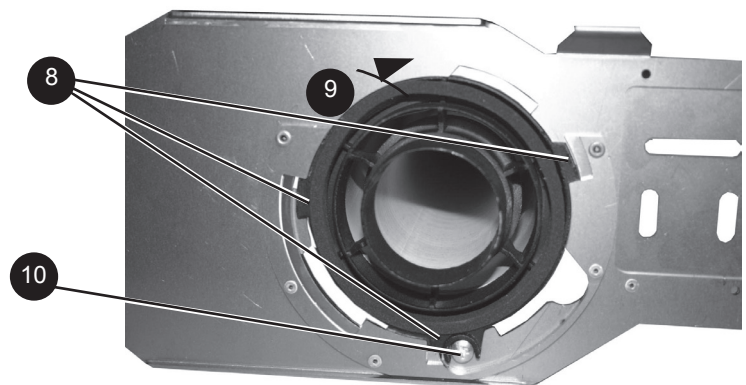
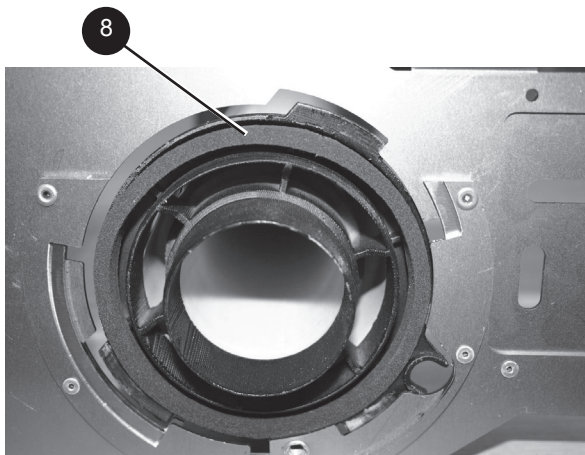
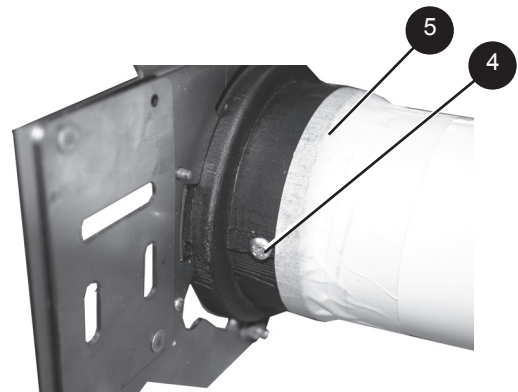

INSTALLATION

31 MOUNTING THE BOILER - REAR FLUE OUTLET KIT (55/80)

1. Remove the rear flue blanking disk.
2. Lift the boiler onto the wall plate, (refer to the introduction section for safe handling advice), ensuring the boiler is offered to the bracket tabs at an angle as shown below, and carefully allow the boiler to swing down to the wall as this movement engages the rear flue air and flue seal.
3. Screw the boiler bottom retaining bracket to the wall with the screw provided.
4. Remove the top flue blanking disk refer to Frame 26. Fill the condensate trap within the boiler by pouring a cupful of water into the flue outlet. Take care to ensure that the water is only poured into the flue outlet, and does not spill into the boiler casing.
5. Replace the top flue blanking disc and retain with the horseshoe bracket and fixing screw previously removed.

During assembly check that the flue seals do not become dislodged.

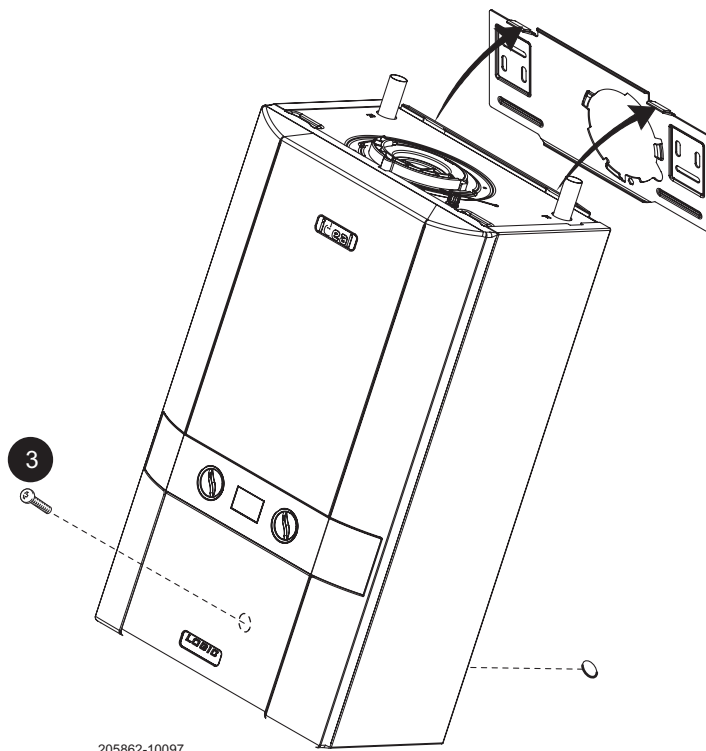
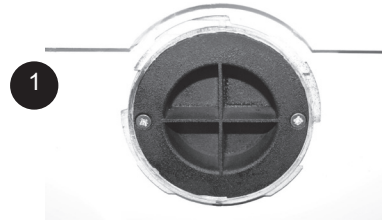

205862-10097

INSTALLATION

32 FITTING THE OPTIONAL ROOF FLUE KIT (Flat or Pitched)

Note.

A flat or pitched roof flashing plate (not supplied) is required before proceeding with the installation of this kit.

This kit is suitable for both flat and pitched roof terminations, using a concentric flue to run vertically from the top of the boiler and terminating above roof level.

Connection to the top of the boiler is made using a separately supplied vertical connector.

WEATHER PROOFING

Where the flue passes through the roof line an adequate seal must be made. This is achieved by using either:

- Flat roof weather collar
- or
- Universal weather collar.

ACCESSORIES

Flue Duct Extension Kits are available for flue lengths extending beyond 1m. These packs contain 1m extension ducts and may be cut to the desired length.

If the offset vertical option is used an elbow Kit is required. For a full accessories list refer to page 6, Optional Extras.

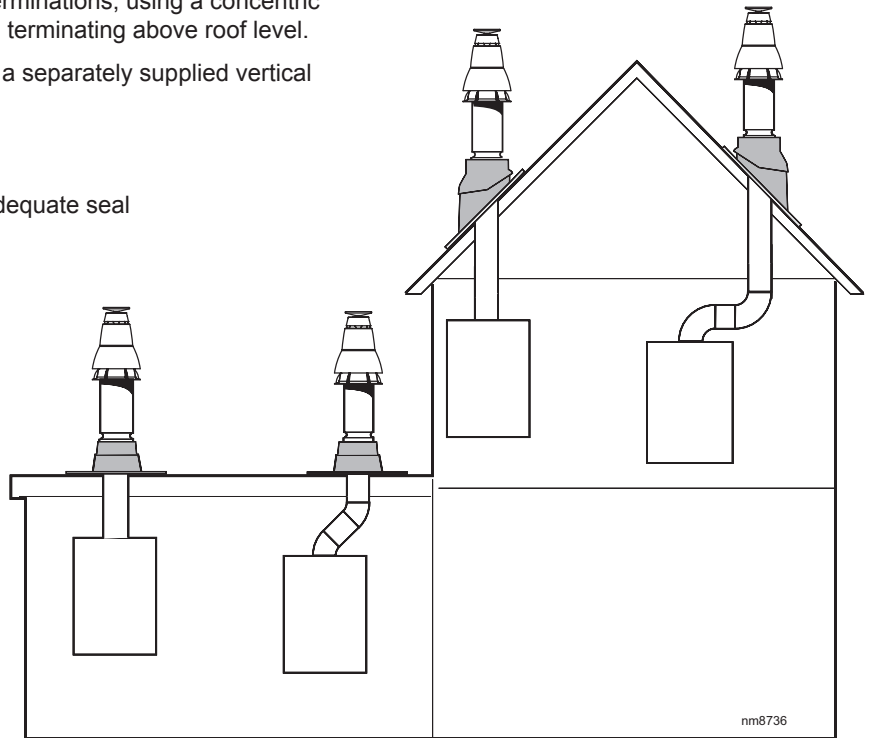

33 ROOF FLUE KIT CONTENTS / OPTIONS

Flue Terminal
UIN 203132

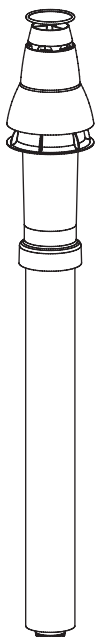

Flue Seal Collar - Flat Roof
UIN 152259

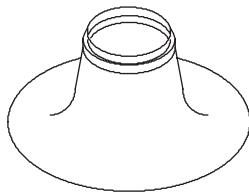

Vertical connector
UIN 204645

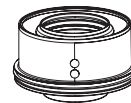

90° elbow
UIN 203130



45° elbow
UIN 203131

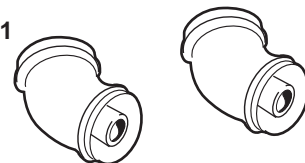

Flue Seal Collar - Tile Roof
UIN 152258

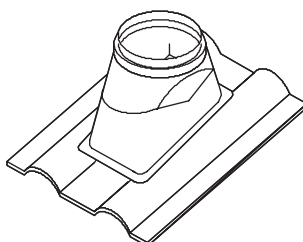

Roof Flue Extension Duct
UIN 203129

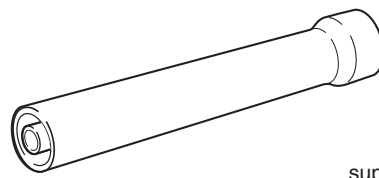

Flue duct support



Flue duct support

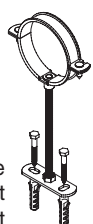

3G9626a

INSTALLATION

34 FLUE TERMINAL POSITION

The terminal should be positioned so that products of combustion can safely disperse at all times.

Plumbing may occur at the termination so, where possible, terminal positions where this could cause a nuisance should be avoided.

Minimum dimensions are shown below

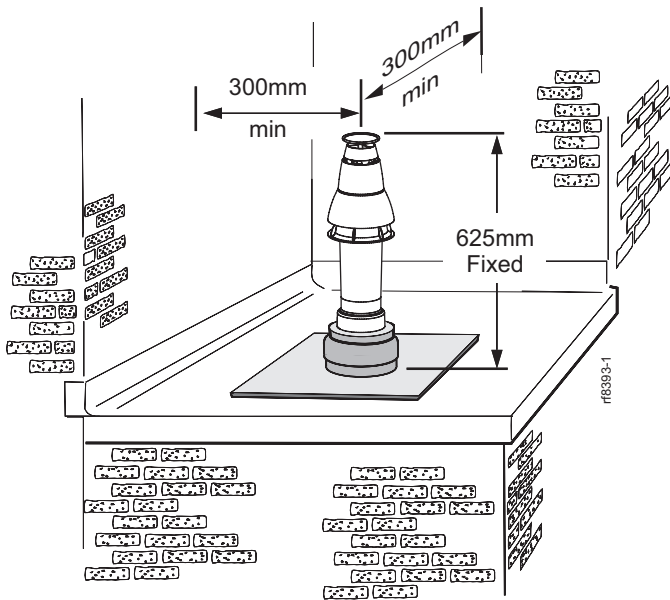

Flat roof - with structure

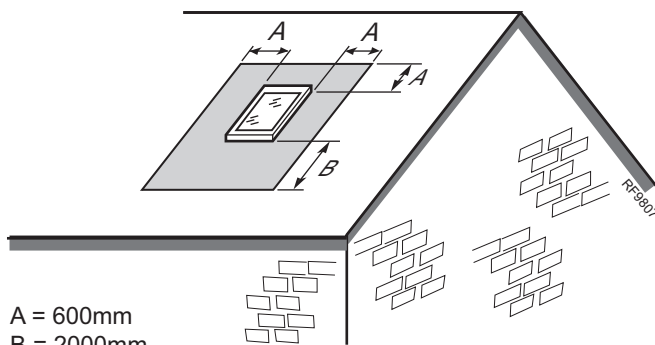

A = 600mm
B = 2000mm

The flue terminal shall not penetrate the shaded area of the roof

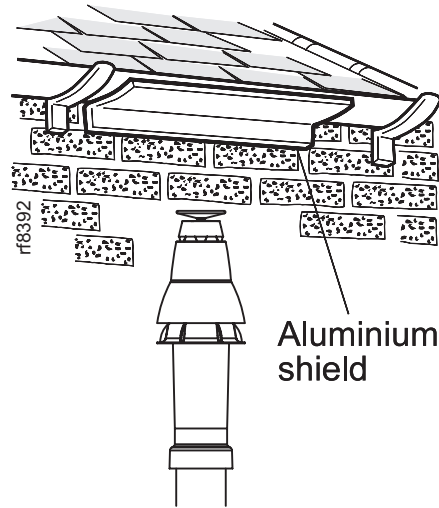

Aluminium shield

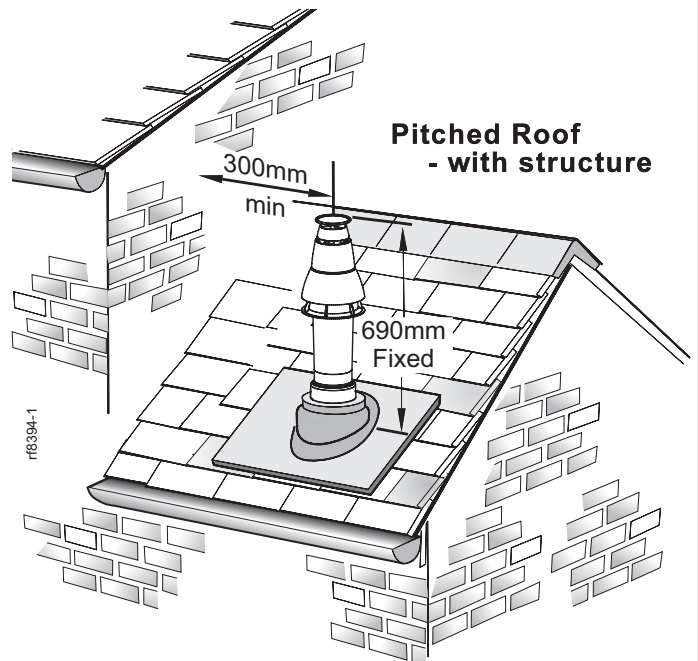

Pitched Roof - with structure

| Terminal Position | Minimum Dimension |
|---|-------------------|
| Directly below an opening, air brick, windows, etc. | 300 mm |
| Below plastic / painted gutters | 300 mm |
| Painted surface | 300 mm |
| Below eaves or balcony | 500 mm |
| Below velux windows | 2000mm |
| Above or side of velux windows | 600mm |

Note.

The equivalent flue length resistance of the elbow kits are:

90° elbow kit = 1m

45° elbow kit = 0.6m

INSTALLATION

35 ASSEMBLING THE ROOF FLUE KIT

Determine the correct height that the flue should terminate above the roof. If after calculating or measuring the overall flue height from the top of the boiler, it is necessary to cut both pipes of assembly A, then ensure they are cut equally leaving the inner flue tube longer than the outer air tube as supplied.

Ensure the cut pipe ends are free from any burrs.

1. Position the roof flashing plate (supplied separately) over the hole cut in the roof and insert flue terminal from the roof end.

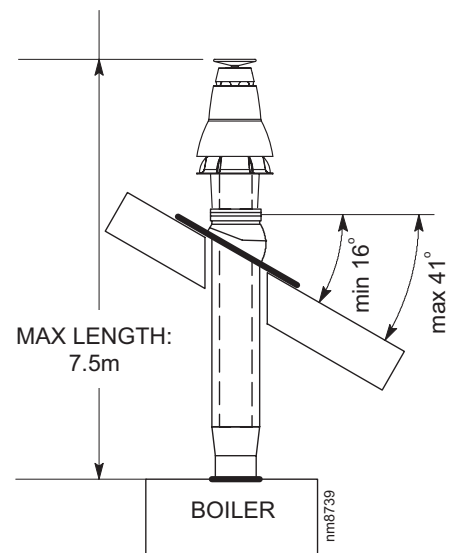
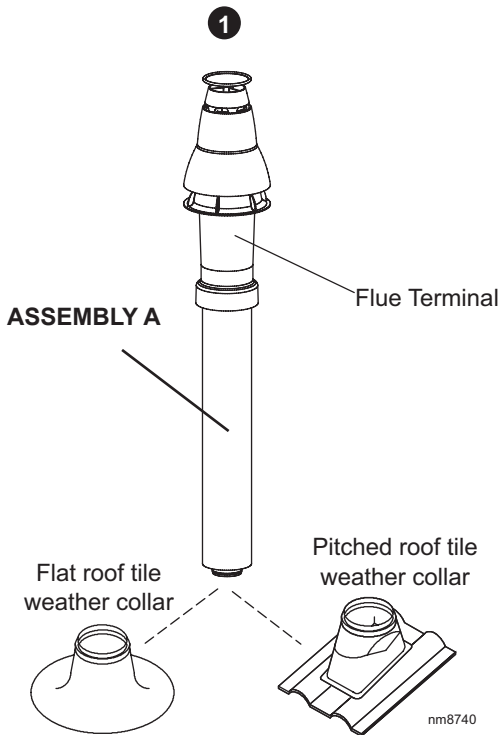

2. Fit the vertical connector (supplied separately) in accordance with the instructions provided with the vertical connector kit.
3. Secure the vertical connector by applying downward pressure on the connector.
4. Engage the clamp in its slide mechanism and push it horizontally backwards, locating on BOTH plastic pegs BEFORE the front retaining clip is fully located (as shown in Frame 26).
5. "Push" fit extension duct (if required (supplied separately)) into vertical connector.
6. If the last extension duct requires cutting, measure 'X', the

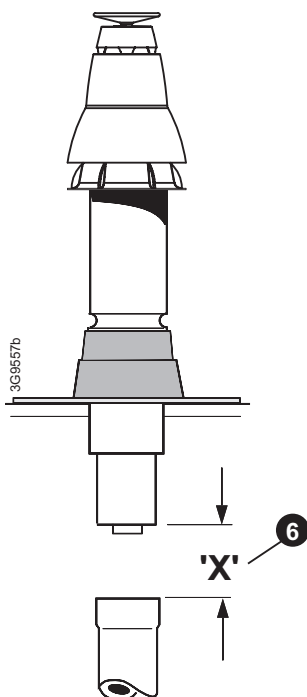
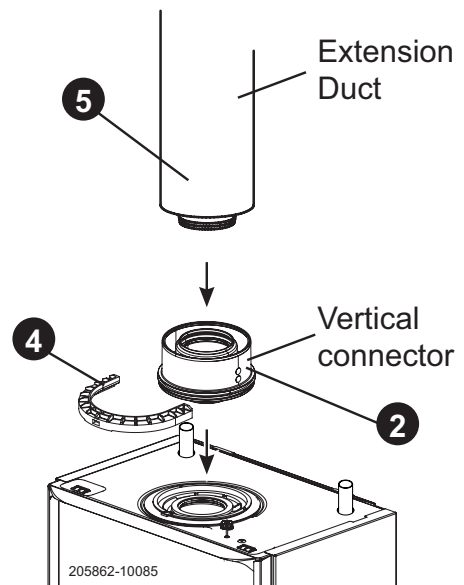

distance (outer ducts), between the duct and the terminal and add 100 mm to this dimension. This gives the length of the last extension duct.

Note. Check the position of the inner flue duct relative to the outer duct on the assembled extension duct(s) and ensure the terminal flue duct is cut longer than the air duct to ensure engagement in the final flue duct seal.

7. Finally ensure the roof flashing plate is correctly sealed to the roof.

INSTALLATION

36 CONDENSATE DRAIN

Ensure that the siphon is full of water before commissioning the boiler.

The routing of the drain must be made to allow a minimum fall of 1 in 20 away from the boiler, throughout its length.

The drainage pipework must be arranged so that obstruction (e.g. through freezing) of external drainage pipe does not give rise to spillage within the dwelling.

IMPORTANT.

All pipework and fittings in the condensate drain system must be made of plastic. No other materials may be used.

The drain outlet on the boiler is standard 21.5mm overflow pipe and is suitable for either push fit or solvent weld applications. This size must not be reduced in any part of its length.

The boiler includes as standard, a 75mm condensate trap. The condensate trap also includes a siphon to reduce the possibility of freezing in the drain outlet.

If external condensate pipe run is greater than 3m then pipe should be 32mm nominal diameter. Consideration should be given to insulating external condensate pipe runs.

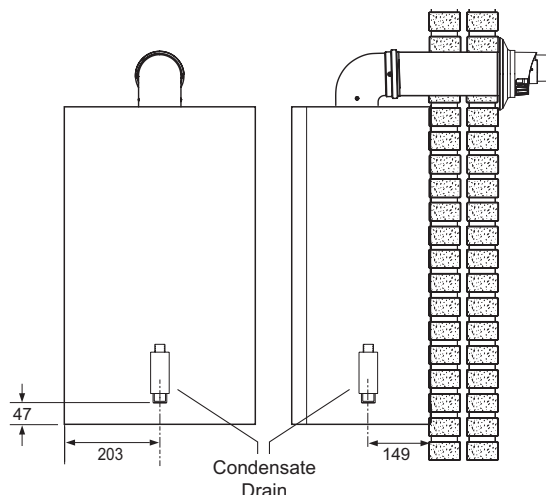

37 CONDENSATE PIPE TERMINATION CONFIGURATIONS

Notes: ALL EXTERNAL PIPE RUNS MUST BE IN ACCORDANCE WITH BS 6798

1. INTERNAL TO SINK WASTE UPSTREAM OF SINK WASTE TRAP

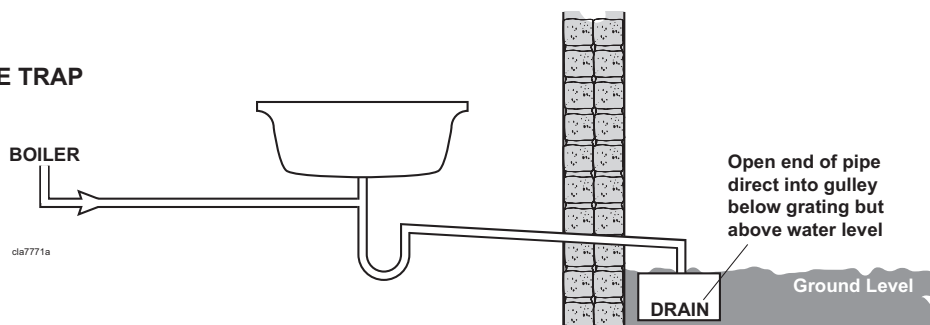

3. INTERNAL CONNECTION TO SOIL AND VENT STACK

* Make connection to SVP using a solvent welded saddle

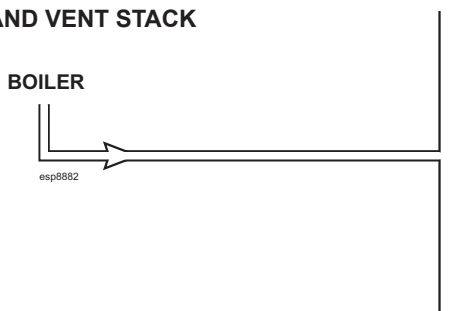

4. TERMINATION TO SOAK AWAY

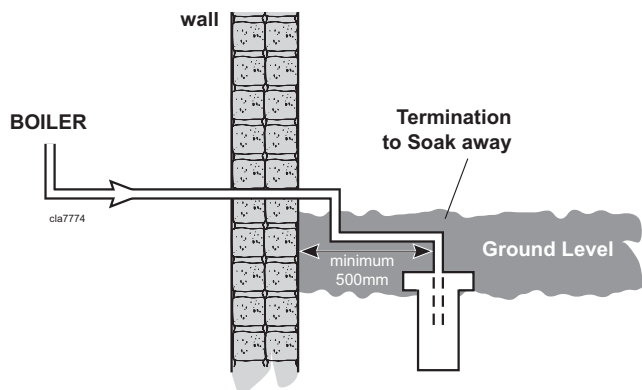

5. TERMINATION TO DRAIN / GULLY

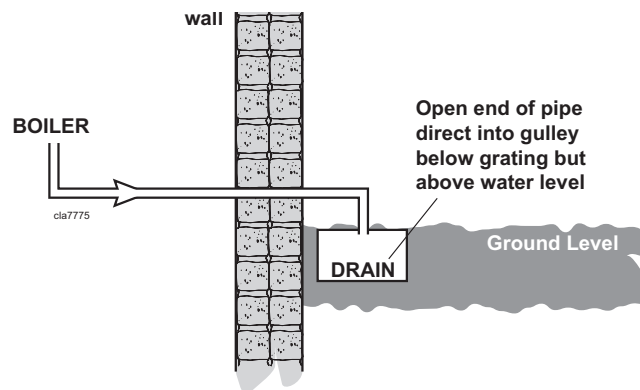

INSTALLATION

38 CONNECTIONS

NOTES.

Ensure all pipe blanking plugs are removed before connecting.

WATER CONNECTIONS

The boiler flow and return pipes are supplied fitted to the boiler and ready for top connection.

Note. For heating loads in excess of 17.6kW (60,000 Btu/h) use 28mm x 22mm connectors to connect the boiler flow and return pipes to 28mm.

Top Connection

Connect the system pipework to the boiler flow and return pipes.

An optional stand-off kit is available where system pipework needs to be taken downwards.

GAS CONNECTION

IMPORTANT. The gas service cock is sealed with a non-metallic blue fibre washer, which must not be overheated when making capillary connections. Refer to Frame 1 for details of the position of the gas connection.

For additional gas supply information refer to "Gas Supply" on page 8.

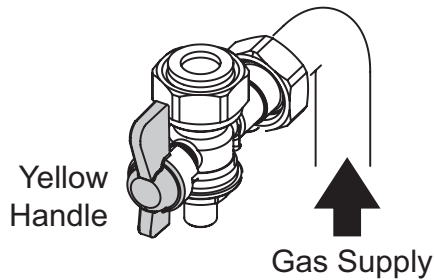
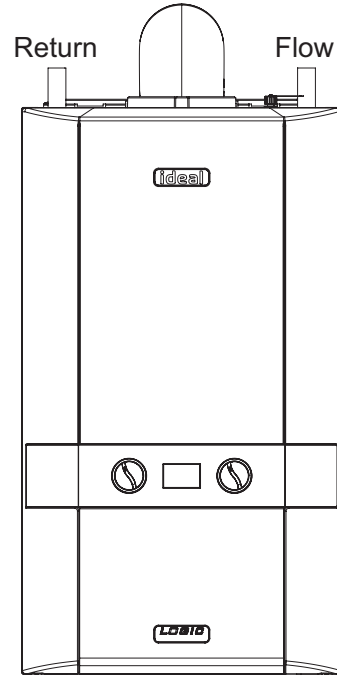

Note. The gas isolation handle is shown in the open position.

39 ELECTRICAL CONNECTIONS

WARNING. This appliance MUST be earthed.

A mains supply of 230Vac ~ 50 Hz is required.

The fuse rating should be 3A. All external controls and wiring must be suitable for mains voltage.

Wiring external to the boiler MUST be in accordance with the current I.E.E. (BS.7671) Wiring Regulations and any local regulations.

Wiring should be 3 core PVC insulated cable, not less than 0.75mm² (24 x 0.2mm), and to BS 6500 Table 16. For IE reference should be made to the current ETCI rules for electrical installations.

The mains supply to the boiler and system wiring centre shall be through one common fused double pole isolator. For heating systems, and where practicable replacement boiler installations, the isolator shall be situated adjacent to the appliance.

NOTE. THE APPLIANCE MUST BE WIRED WITH A PERMANENT LIVE SUPPLY. THE SYSTEM PUMP MUST BE WIRED TO THE BOILER (SEE FRAME 41). THE BOILER WARRANTY WILL BE INVALID IF THIS REQUIREMENT IS NOT COMPLIED WITH.

40 INTERNAL INSTALLER WIRING

The Logic Heat boiler must be connected to a permanent live supply and NOT switched by thermostats/programmers.

To install the mains cable:

1. Isolate the mains supply to the boiler.
2. Remove the front panel. Refer to Frame 12.
3. Swing the control box down into the servicing position.
4. Route incoming cable through a grommet in the bottom panel (note that the grommets are "blind" and will require puncturing) and secure using the clamp and screws provided in the hardware pack.
5. Connect the mains cable to the terminal block as shown.

Connecting the Switched Live to the Boiler

1. Consult the Y Plan and S Plan diagrams below.
2. Isolate the mains supply to the boiler
3. Remove the front panel. Refer to Frame 12.
4. Swing the control box down into the servicing position.
5. Route incoming cable through a grommet in the bottom panel (note that the grommets are "blind" and will require puncturing) and secure using the clamp and screws provided in the hardware pack.
6. Connect the switched live to the terminal block as shown.

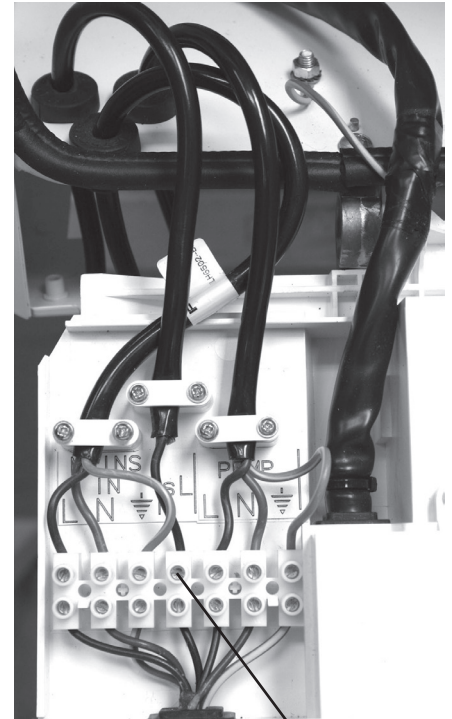

Frost Thermostat - Wiring

If parts of the system are vulnerable to freezing or the programmer is likely to be left off during cold weather, a frost stat should be fitted in conjunction with a pipe thermostat.

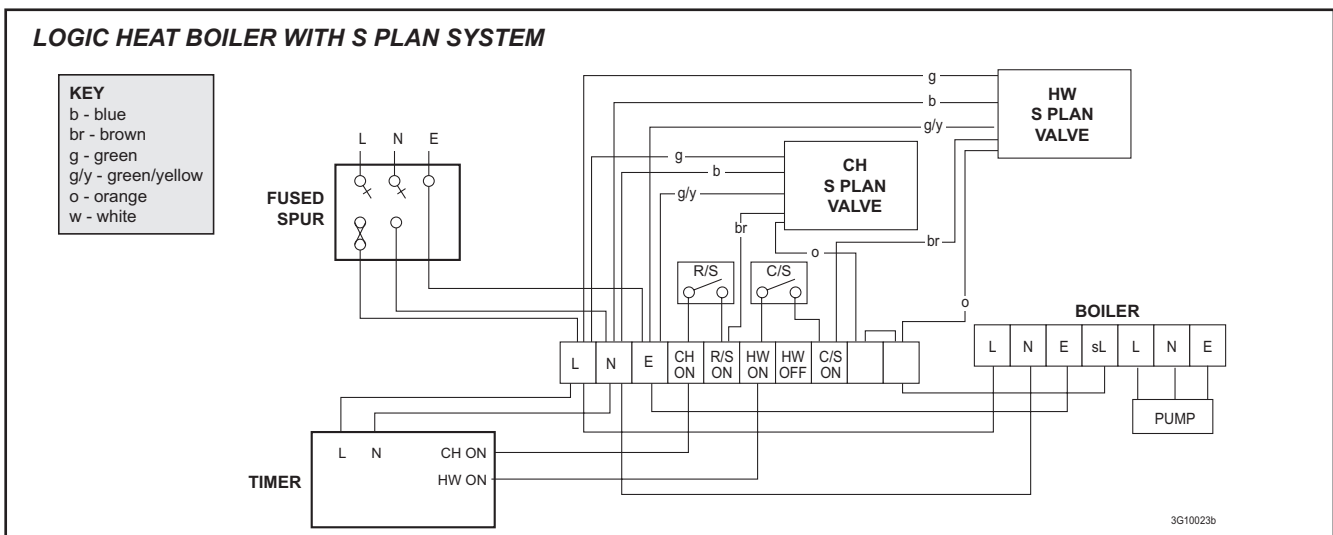
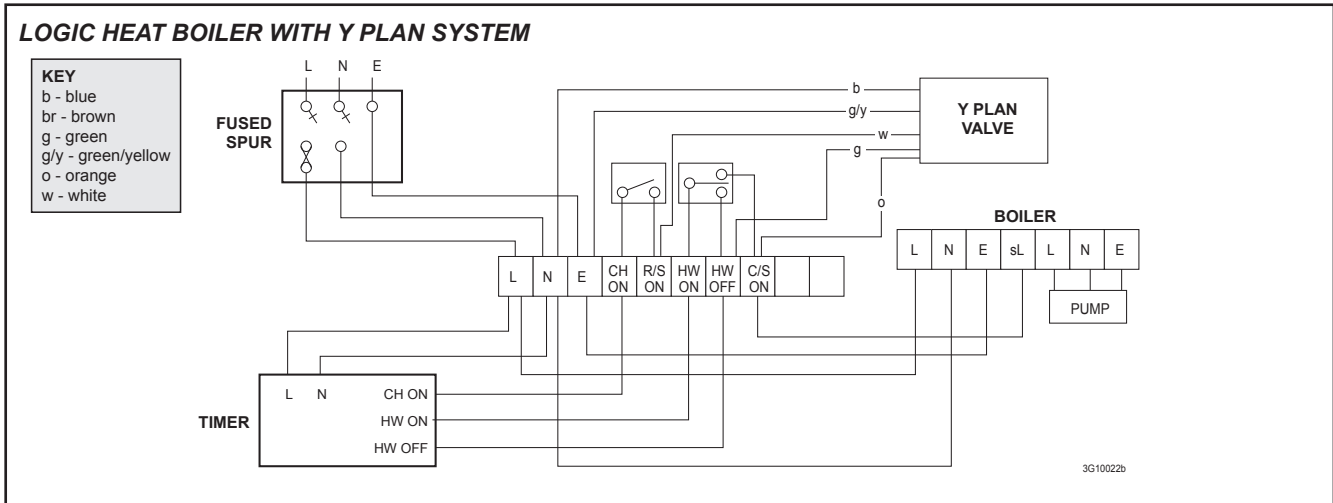

41 WIRING THE SYSTEM PUMP

NOTE. THE APPLIANCE MUST BE WIRED WITH A PERMANENT LIVE SUPPLY. THE SYSTEM PUMP MUST BE WIRED TO THE BOILER. THE BOILER WARRANTY WILL BE INVALID IF THIS REQUIREMENT IS NOT COMPLIED WITH.

1. Isolate the mains supply to the boiler.
2. Remove the front panel. Refer to Frame 12.
3. Swing the control box down into the service position.
4. Loosen the pump wire cable clamp.
5. Route pump cable through the cable clamp and grommet and re-tighten to provide cord anchorage.
6. Connect the live, neutral and earth wires to the terminal strip. When making the mains electrical connections to the boiler it is important that the wires are prepared in such a way that the earth conductor is longer than the current carrying conductors, such that if the cord anchorage should slip, the current carrying conductors become taut before the earthing conductor.
7. Swing the control box back up into the operating position and re-fit the front panel ensuring a good seal is made.

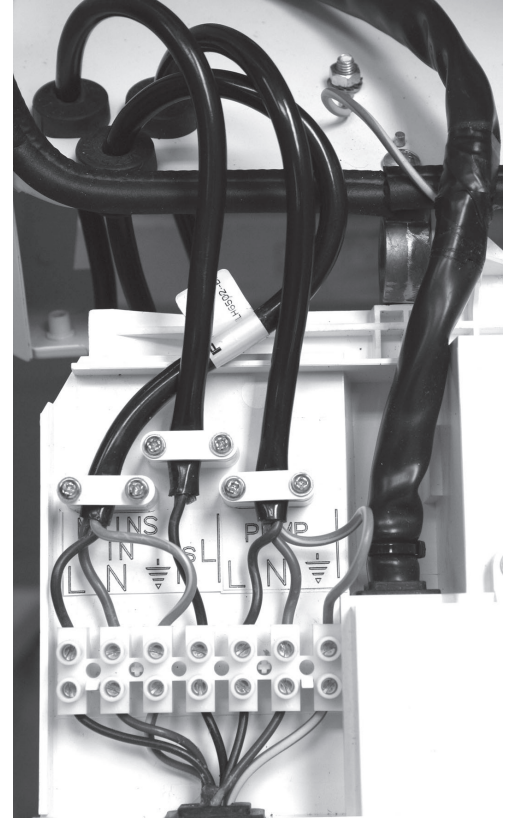

42 EXTERNAL ELECTRICAL CONTROLS

Wiring External to the Boiler

The fuse rating should be 3A.

Wiring external to the boiler **MUST** be in accordance with the current I.E.E. (BS.7671) Wiring Regulations and any local regulations.

Difficulty in wiring should not arise, providing the following directions are observed:

1. The appliance must be wired with a permanent live supply. External controls should **NOT** be wired in series with this mains input. Controlling the mains input in this way will prevent the pump overrun sequence and may cause damage to the heat exchanger.
2. 230V AC output is provided and must be used for the system pump. Care must be taken to ensure that the earth conductor is longer than the current carrying conductors for reasons given in Frame 41 - item 6.

Frost Protection

If parts of the pipework run outside the house or if the boiler will be left off for more than a day or so then a frost thermostat should be wired into the system.

The frost thermostat should be sited in a cold place but where it can sense heat from the system.

Note. *If the boiler is installed in a garage it may be necessary to fit a pipe thermostat, preferably on the return pipework.*

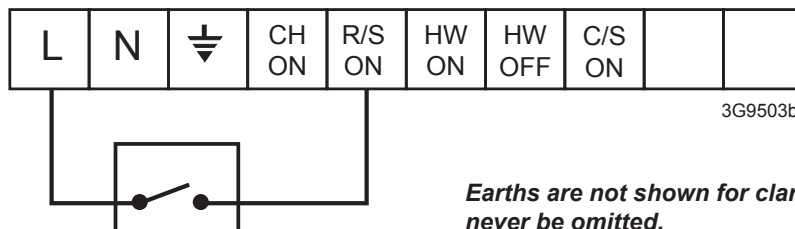

Earths are not shown for clarity but must never be omitted.

43 WIRING DIAGRAM

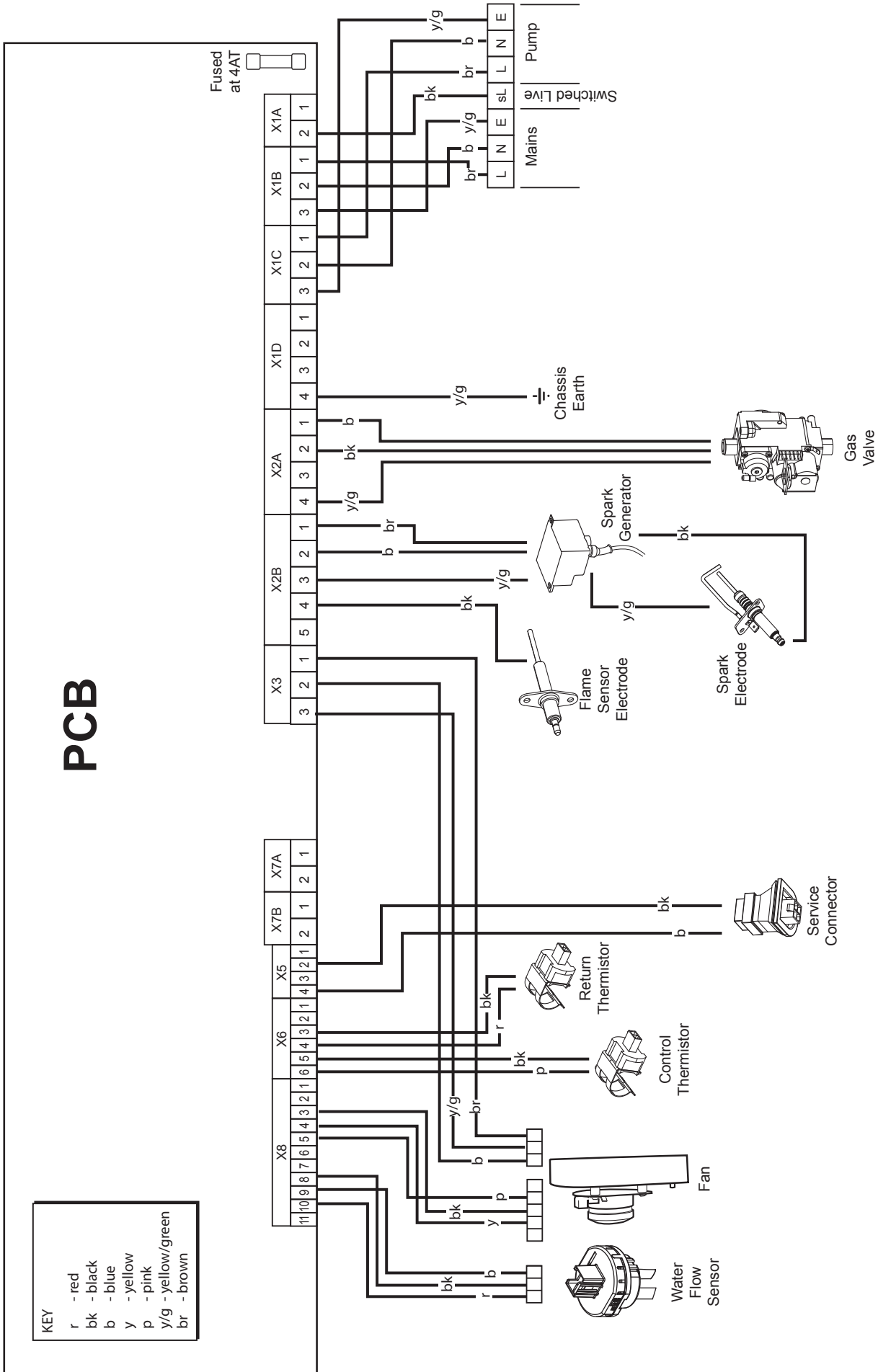

KEY
 r - red
 bk - black
 b - blue
 y - yellow
 p - pink
 y/g - yellow/green
 br - brown

205862-10075b

44 COMMISSIONING AND TESTING

A. Electrical Installation

1. Checks to ensure electrical safety should be carried out by a competent person.
2. ALWAYS carry out the preliminary electrical system checks, i.e. earth continuity, polarity, resistance to earth and short circuit, using a suitable test meter.

B. Gas Installation

1. The whole of the gas installation, including the meter, should be inspected and tested for tightness and purged in accordance with the recommendations of BS. 6891. In IE refer to IS.813:2002.
2. Purge air from the gas installation by the approved methods only.

WARNING. Whilst effecting the required gas tightness test and purging air from the gas installation, open all windows and doors, extinguish naked lights and **DO NOT SMOKE.**

GENERAL

Please Note: The combustion for this appliance has been checked, adjusted and preset at the factory for operation on the gas type defined on the appliance data plate. No measurement of the combustion is necessary. **DO NOT** adjust the air/gas ratio valve.

Having checked:

- That the boiler has been installed in accordance with these instructions.
- The integrity of the flue system and the flue seals, as described in the Flue Installation section.

Proceed to put the boiler into operation as follows:

CHECK THE OPERATIONAL (WORKING) GAS INLET PRESSURE

Set up the boiler to operate at maximum rate.

With the boiler operating in the maximum rate condition check that the operational (working) gas pressure at the inlet gas pressure test point complies with the requirements - refer to "Gas Supply" on page 8.

Ensure that this inlet pressure can be obtained with all other gas appliances in the property working.

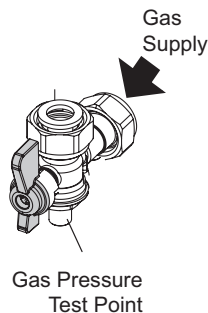

ATTENTION !
IT IS A CONDITION OF THE MANUFACTURERS WARRANTY THAT THE BENCHMARK COMMISSIONING CHECKLIST IS FULLY COMPLETED AND LEFT WITH THE APPLIANCE

45 INITIAL LIGHTING

Legend

- A. CH temperature control
- B. Mode Control Knob
- C. Boiler Status
- D. Burner 'on' indicator
- E. Gas Inlet Pressure Test Point
- F. Gas Service Cock

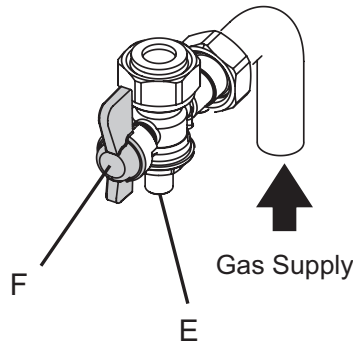
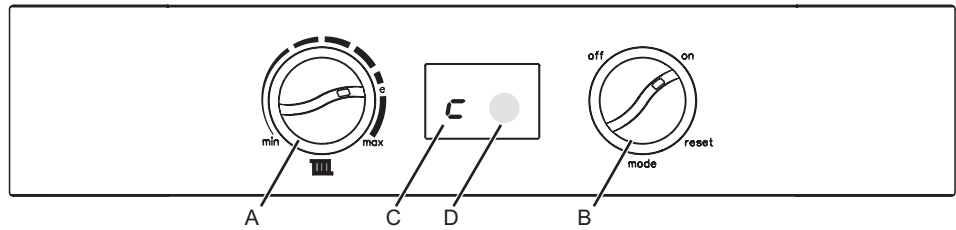

205862-10076

1. Check that the system has been filled and that the boiler is not airlocked.

Note.

It is important the burner is not operated before the system is fully vented of air. If it is necessary to operate the system pump to assist venting of the air this must be done with the gas service cock turned off.

2. Refit the boiler front panel. Refer to Frame 50.
3. Check that the electrical supply is OFF.
4. Check that the boiler mode control knob (B) is off.
5. Check that the gas service cock (F) is OPEN.
6. Slacken the screw in the inlet pressure test point (E) and connect a gas pressure gauge via a flexible tube.
7. Switch the electricity supply ON and check all external controls are calling for heat.

CENTRAL HEATING

8. Set the CH temp control (A) to max and turn the mode control knob (B) to ON. The boiler control should now go through its ignition sequence until the burner is established.
9. If the boiler does not light code **L-2** will be displayed. After 5 attempts the boiler will lock out and display fault code **L-2** constantly. Reset the boiler (Refer to Frame 47). The boiler will repeat its ignition sequence. If reset occurs 5 times within 15 minutes then **L-5** will be shown. If power is removed this will be reset.

When the burner is established the BLUE 'Burner On' neon (D) will be illuminated, the LED display (C) will show status **c**.

10. Ensure that with the boiler operating the dynamic gas pressure is able to obtain maximum output. Refer to Table 2.

IMPORTANT

The gas input to the burner is regulated by the gas valve according to the air flow produced by the fan. It is NOT user-adjustable. Any interference to sealed settings on the

valve will adversely affect operation and render our warranty void.

For additional gas supply information refer to "Gas Supply" on page 8.

THE DISPLAY

The user control has one neon and one display to inform the user about the status. The display will show the status of the boiler. The neon will show the status of the flame. If no flame is detected the neon is off. When the flame is detected the neon will be lit permanently.

Below is a list with display function in normal operation.

- 0** Standby, no demand for heat present.
- c** Boiler is active for heating.
- F** Boiler is active for boiler frost protection.
- L** Boiler is in lockout for a specific error. Display will be blinking, alternating with a number or letter to show which error is detected.
- F** Boiler has a fault for a specific error. Display will be blinking, alternating with a number or letter to show which error is detected.

Note: Boiler frost protection - boiler fires if temperature is below 5 degrees C.

Note. The boiler incorporates a fan overrun cycle which MUST NOT be prematurely interrupted by isolation of the mains electricity supply.

INSTALLATION

46 GENERAL CHECKS

Make the following checks for correct operation:

CENTRAL HEATING (CH) MODE

1. Ensure that the CH external controls are calling for heat.

The display should read: 

2. Check the boiler gas rate when the boiler is at full output.

Check at the gas meter, with no other appliance in use.

Refer to Table 2 for gas rate.

3. Set the central heating external controls to OFF. The burner should go off and the pump continue to run for two minutes

The display should read: 

4. Check the correct operation of all system controls. Operate each control separately and check that the main burner responds.

WATER CIRCULATION SYSTEM

1. With the system COLD, check that the initial pressure is correct to the system design requirements.

For pre-pressurised systems, this should be 1.0 bar.

2. With the system HOT, examine all water connections for soundness. The system pressure will increase with temperature rise but should not exceed 2.5 bar.

3. With the system still hot, turn off the gas, water and electricity supplies to the boiler and drain down to complete the flushing process.

Note: A flushing solution should be used during the flushing procedure. Flushing solutions: Fernox Superfloc, Sentinel X300 (new systems) or X400 (existing systems). Refer to Frame 5.

4. Refill and vent the system, add inhibitor (see Frame 5), clear all air locks and again check for water soundness.
5. Reset the system initial pressure to the design requirement.
6. Balance the system. Refer to Frame 4.
7. Check the condensate drain for leaks and check that it is discharging correctly.
8. Finally, set the controls to the User's requirements.

WATER TEMPERATURES

Temperatures can be selected using the CH temp ctrl (A)

| Knob Setting | CH Flow Temp °C (°F) |
|--------------|----------------------|
| Max | 80 (176) |
| Min | 30 (86) |

47 RESET PROCEDURE

To reset boiler, turn the mode control knob (B) to reset position and immediately turn knob back to required setting. The boiler will repeat the ignition sequence.

Legend

- A. CH temperature control
- B. Mode Control Knob
- C. Boiler Status
- D. Burner 'on' indicator

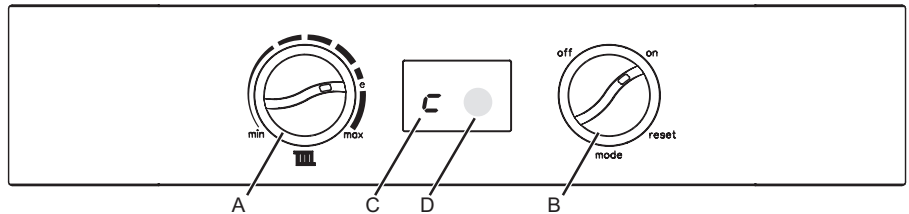

48 HANDING OVER

After completing the installation and commissioning of the system the installer should hand over to householder by the following actions:

1. Hand the User Instructions to the householder and explain his/her responsibilities under the relevant national regulations.
 2. Explain and demonstrate the lighting and shutting down procedures.
 3. The operation of the boiler and the use and adjustment of all system controls should be fully explained to the householder, to ensure the greatest possible fuel economy consistent with the household requirements of both heating and hot water consumption.
Advise the User of the precautions necessary to prevent damage to the system and to the building, in the event of the system remaining inoperative during frosty conditions.
 4. Explain the function and the use of the boiler heating controls.
 5. Explain the function of the boiler fault mode.
Emphasise that if a fault is indicated refer to "Fault Codes" in the User Guide.
 6. Explain and demonstrate the function of time and temperature controls, radiator valves etc., for the economic use of the system.
 7. If a timer is fitted draw attention to the timer Users Instructions and hand them to the householder.
 8. Explain Boiler reset procedure.
 9. After installation and commissioning please complete the Benchmark Commissioning Checklist before handover to the customer. For IE, its is necessary to complete a "Declaration of Conformity" to indicate compliance to I.S. 813:2002.
- IMPORTANT**
10. A comprehensive service should be carried out ANNUALLY. Stress the importance of regular servicing by a Gas Safe Registered Engineer. In IE servicing work must be carried out by a Registered Gas Installer (RGI).
 11. Inform the householder of the guarantee/registration found within the envelope pack and the requirement to register it to receive the full benefit of the warranty.

49 SERVICING SCHEDULE

For the very latest copy of literature for specification & maintenance practices, visit our website www.idealheating.com, where you will be able to download the relevant information. N.B. Technical Bulletins are also available on www.idealheating.com.

WARNING. Always turn OFF the gas supply at the gas service cock, and switch OFF and disconnect the electricity supply to the appliance before servicing.

Combustion testing must be carried out by a competent person using a combustion analyser conforming to BS7927.

To ensure the continued safe and efficient operation of the appliance it is recommended that it is checked at regular intervals and serviced as necessary. The frequency of servicing will depend upon the installation condition and usage but should be carried out at least annually.

It is the law that any service work must be carried out by a Gas Safe Registered Engineer. In IE service work must be carried out by a Registered Gas Installer (RGII).

INSPECTION

1. Light the boiler and carry out a pre-service check, noting any operational faults.
2. Check the flue terminal (and terminal guard if fitted) is undamaged and clear of any obstruction.
3. Check all water and gas joints for signs of leakage. Remake any suspect joints ensuring a gas tightness check is carried out if applicable and the water system is correctly refilled, vented and on sealed systems only re-pressurised.

CLEANING PROCEDURE

Note. In order to carry out either servicing or replacement of components the boiler front panel must be removed. Refer to Frame 50.

1. Clean the main burner. Refer to frame 52.
2. Clean the heat exchanger & condensate trap/siphon. Refer to Frames 53 & 54.
3. Check the main injector for blockage or damage. Refer to Frame 51.
4. Check that the flue terminal is unobstructed and that the flue system is sealed correctly.

The cleaning procedures are covered more fully in Frames 51-55 and MUST be carried out in sequence.

IMPORTANT.

6. After completing the servicing or exchange of components always test for gas tightness.
7. When work is complete the front panel MUST be correctly refitted, ensuring that a good seal is made.

Do NOT OPERATE the boiler if the front panel is not fitted.

8. If, for any reason, the condensate trap/siphon has been removed ensure the trap is refilled with water before reassembling.
9. Check the gas consumption.
10. Check combustion by connecting the flue gas analyser to the flue gas sampling point as shown in the diagram and measure CO & CO₂.

If the CO/CO₂ ratio is greater than 0.004 AND the integrity of the complete flue system and combustion circuit seals have been verified and the inlet gas pressure (and gas rate) have been verified, then contact Ideal.

11. Complete the service section in the Benchmark Commissioning Checklist.

GENERAL

Please Note: During routine servicing, and after any maintenance or change of part of the combustion circuit, the following must be checked:

- The integrity of the flue system and the flue seals,
- The integrity of the boiler combustion circuit and the relevant seals
- The operational (working) gas inlet pressure at maximum rate.
- The gas rate
- The combustion performance.

COMPETENCE TO CARRY OUT THE CHECK OF COMBUSTION PERFORMANCE

Please Note: BS 6798:2009 Specification for installation and maintenance of gas-fired boilers of rated input not exceeding 70kW net advises that:

- The person carrying out a combustion measurement should have been assessed as competent in the use of a flue gas analyser and the interpretation of the results.
- The flue gas analyser used should be one meeting the requirements of BS7927 or BS-EN50379-3 and be calibrated in accordance with the analyser manufacturers requirements, and
- Competence can be demonstrated by satisfactory completion of the CPA1 ACS assessment, which covers the use of electronic portable combustion gas analysers in accordance with BS7967, Parts 1 to 4.

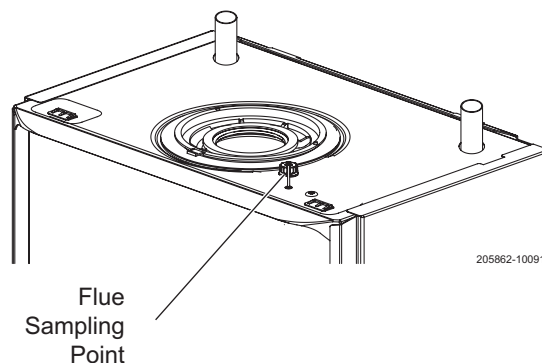

SERVICING

50 BOILER FRONT PANEL REMOVAL / REPLACEMENT

REMOVAL

1. Loosen the two screws retaining the front panel.
2. Pull the two spring clips down to disengage and pull panel forward and upward and remove.

REPLACEMENT

3. Hook the panel onto the top retaining clips.
4. Push the panel until the 2 bottom spring clips engage ensuring the 4 control knobs line up with the holes in the front panel.
5. Re-tighten the two retaining screws.

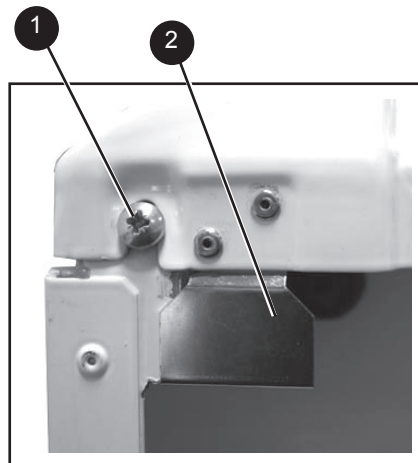

view from bottom of boiler

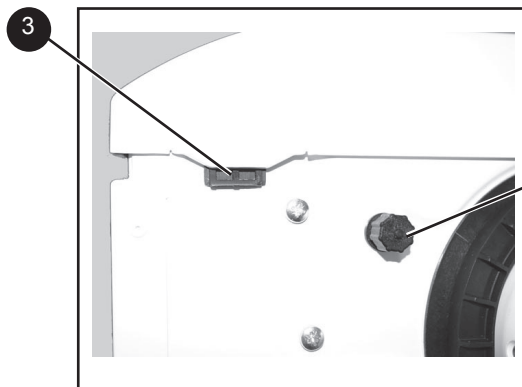

Flue sampling point

view from top of boiler

51 FAN AND VENTURI ASSEMBLY REMOVAL AND CLEANING

1. Disconnect the electrical leads from the fan.
2. Undo the gas pipe union connection to the injector housing.
3. Remove the extended nut on the fan mounting bracket.
4. Lift off fan and venturi assembly.
5. Inspect the injector for blockage or damage.
6. Inspect fan outlet sealing gasket and replace if necessary.

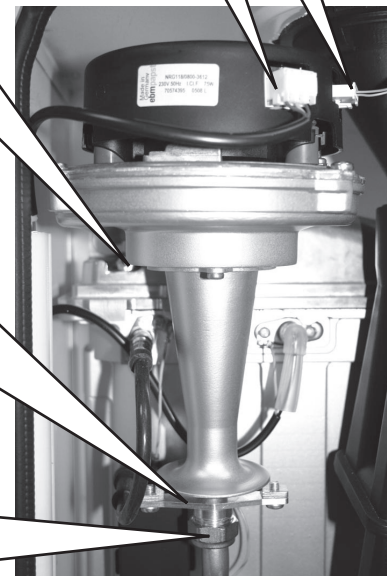
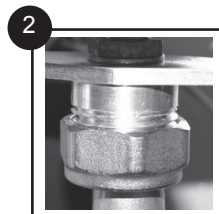
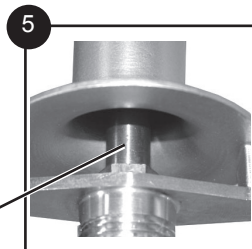
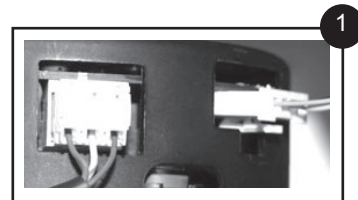
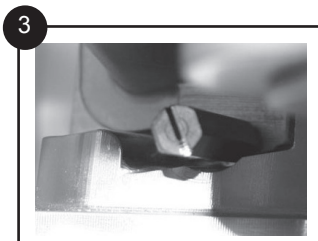

52 BURNER REMOVAL AND CLEANING

1. Ensure the sump is fully drained
2. Undo the two screws and remove the sump cover retaining the lower flue manifold.
3. Lift the manifold to clear the bottom sealing gasket and remove manifold.
4. Remove the 2 burner front fixing screws and loosen the 2 rear extended nuts by at least ten turns.
5. Lift off the burner from the combustion chamber. To facilitate the removal angle the burner as shown.

IMPORTANT

The burner head is a ceramic plaque construction. Care must be taken to ensure that **the burner is not placed down upon its face** as this may cause damage to the ceramic.

6. Brush off any deposits that may be on the ceramic with a SOFT brush.
7. Inspect the sealing gasket around the burner for any signs of damage. Replace as necessary.

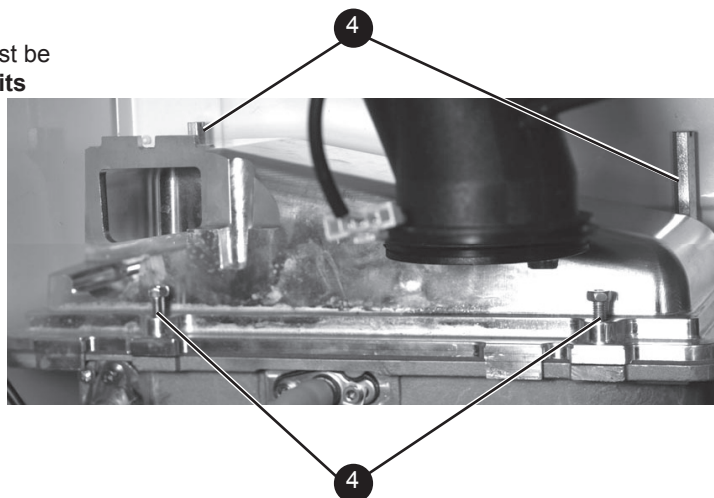
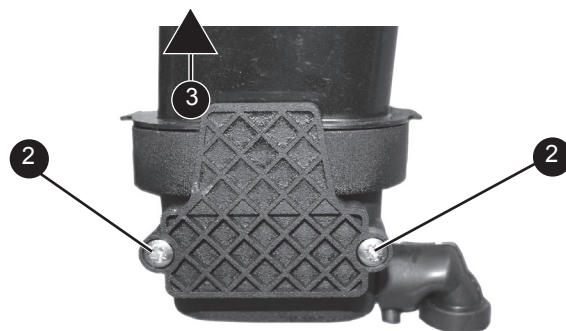

53 CLEANING THE CONDENSATE TRAP/SIPHON

1. Remove the cleaning plug taking care with any residual condense.
2. Pull off the rubber pipe noting the position and flush out any deposits with clean water.
3. Replace the cleaning plug and refill the siphon with water.
4. Replace the rubber pipe connector with the twin wall seal fitted to the condensate siphon.

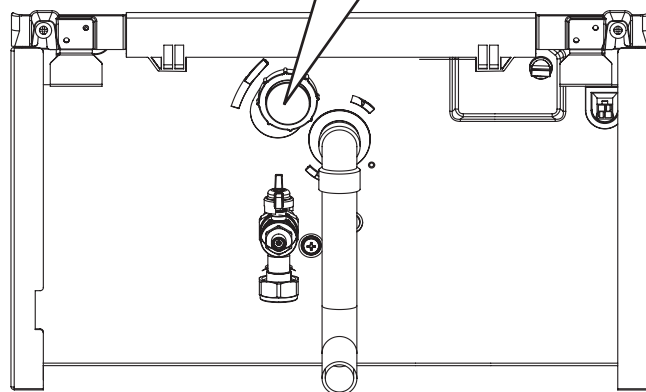
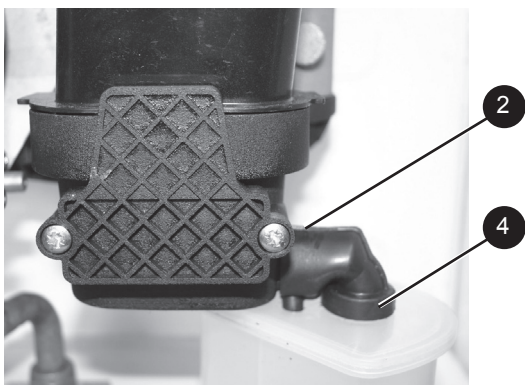
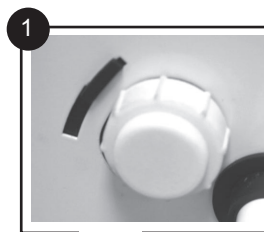

205862-10093

SERVICING

54 CLEANING THE HEAT EXCHANGER

Note: Ensure the condensate trap/siphon is fully drained before cleaning. Refer to Frame 53.

1. Remove ignition and flame detection electrodes. Refer to Frames 61 & 62.
2. It is advisable to replace the sump cover prior to the water flush process.
3. Thoroughly flush the heat exchanger by pouring water into the top of the combustion chamber ensuring the full top area is covered.
4. Remove the sump cover and clean loose deposits from the sump.
5. Inspect the ignition and detection electrodes. Ensure that they are clean and in good condition - replace if necessary.
6. Re-fit the ignition and flame detection electrodes, ensuring that both earth tabs are fitted to ignition electrode.
7. Check that the ignition and detection gaps are correct. Refer to Frames 61 & 62.

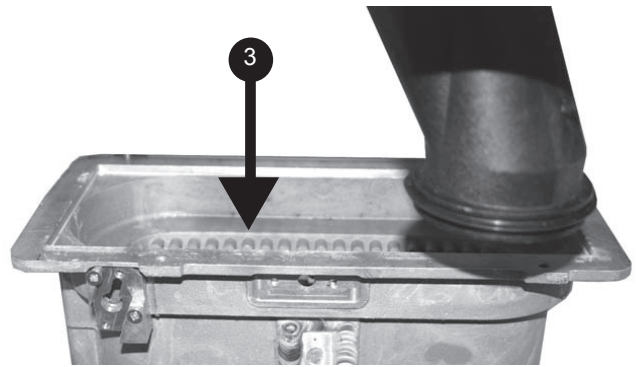
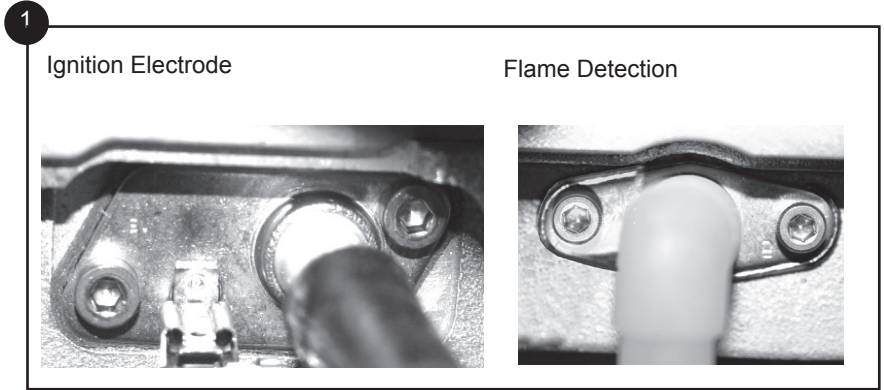

55 REASSEMBLY

Reassemble the boiler in the following order:

1. Ensure that the condensate trap/siphon is full of water.
2. Refit the burner ensuring the sealing gasket is correctly positioned and free from damage (tighten the 4 fixing screws in the sequence shown below - A,B,C,D).
3. Refit the fan / venturi assembly ensuring the retaining tabs are correctly positioned and the sealing gasket is correctly positioned and free from damage.
4. Reconnect the fan electrical leads.
5. Remove the sump cover and refit the lower flue manifold as shown.
6. Refit the sump cover.
7. Refit the boiler front panel.
IMPORTANT. Ensure that the boiler front panel is correctly fitted and that a good seal is made.
8. Swing the control box back into its working position and secure.
9. Turn on the gas supply at the gas service cock.
10. Reconnect the electrical supply.
11. Check operation of the boiler. Refer to Frames 45, 46 & 47.

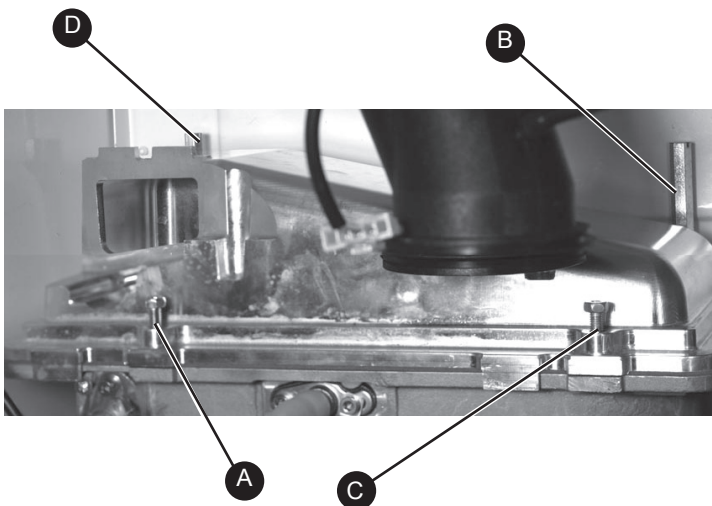

56 REPLACEMENT OF COMPONENTS

GENERAL

When replacing ANY component

1. Isolate the electricity supply.
2. Turn off the gas supply.
3. Remove the boiler front panel. Refer to Frame 50.
4. Release the retaining clip and swing the control box down into the servicing position.

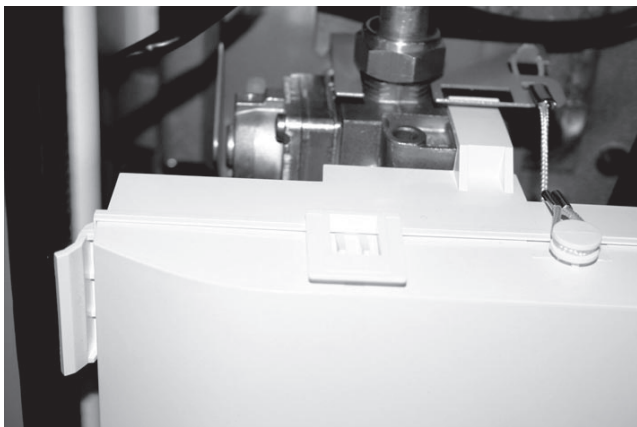

After replacing ANY component check operation of the boiler, including gas soundness, gas rate and combustion test.

IMPORTANT.

When work is complete, the front panel must be correctly refitted - ensuring that a good seal is made.

Notes.

1. In order to assist fault finding, the control panel has an LED diagnostic display. The key to boiler fault conditions is shown in Frame 71.
2. In order to replace components in Frames 57-70 it is necessary to drain the boiler.

THE BOILER MUST NOT BE OPERATED WITHOUT THE FRONT PANEL FITTED

57 FAN REPLACEMENT

1. Refer to Frame 56.
2. Disconnect the electrical leads from the fan.
3. Undo the gas pipe union connection to the injector housing.
4. Remove the extended nut retaining the fan mounting bracket.
5. Lift and remove the fan and venturi assembly.
6. Remove the screw and twist venturi anti-clockwise to remove venturi assembly, *noting the orientation of the venturi in relation to the fan body.*
7. Transfer the venturi assembly to the new fan, replacing the 'o' ring if evidence of damage or deterioration is visible.
8. Fit the new fan / venturi assembly ensuring the retaining tabs are correctly positioned and the fan outlet sealing gasket is correctly positioned and free from damage. Refit the extended nut.
9. Reassemble the boiler in reverse order, taking care not to overtighten the screw on the fan mounting bracket.
10. Check the operation of the boiler. Refer to Frames 45, 46 & 47.

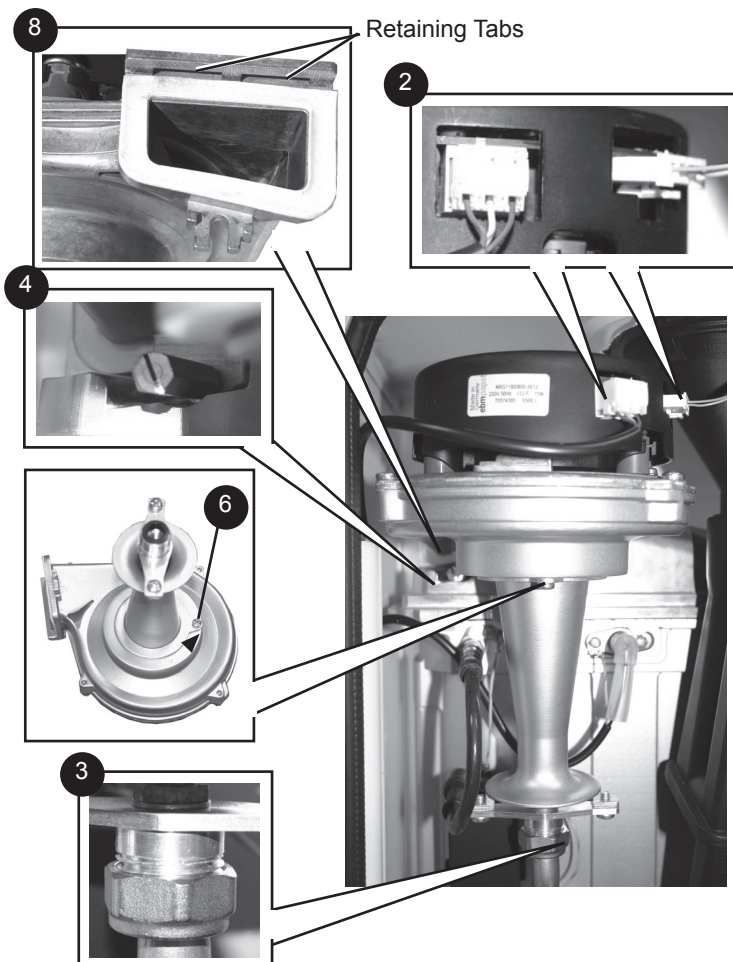

58 BURNER INJECTOR REPLACEMENT

1. Refer to Frame 56.
2. Disconnect the electrical leads from the fan.
3. Undo the gas pipe union connection to the injector housing.
4. Loosen the screw retaining the fan mounting bracket.
5. Lift and remove the fan and venturi assembly.
6. Remove the 2 injector housing screws.
7. Withdraw the injector housing.
8. Fit the new injector housing complete with injector.
9. Reassemble in reverse order, ensuring that the new gas seal supplied is located correctly in the injector housing.
10. Check operation of the boiler. Refer to Frames 45, 46 & 47.

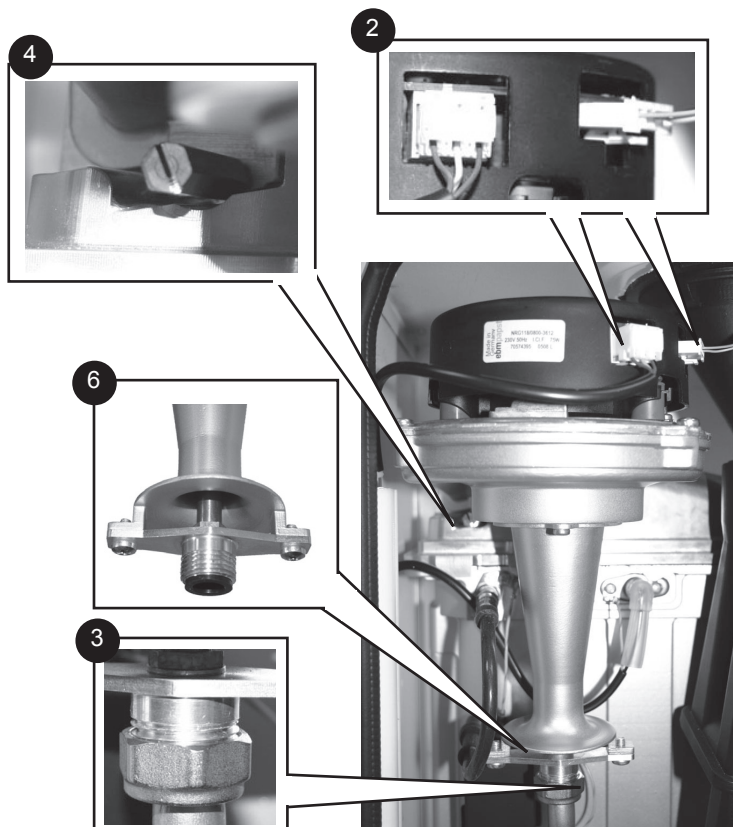

59 BURNER REPLACEMENT

1. See Frame 52.
2. Refer to Frame 56.
3. Undo the two screws and remove the sump cover.
4. Lift the manifold to clear the bottom sealing gasket and remove manifold.
5. Remove the 2 front fixing screws and loosen the 2 rear extended nuts.
6. Lift off the burner from the combustion chamber. To facilitate the removal angle the burner as shown.
7. Fit the new burner, replacing any damaged or deteriorating sealing gasket.
8. Reassemble in reverse order. Refer to Frame 55.
9. Check the operation of the boiler. Refer to Frames 45, 46 & 47.

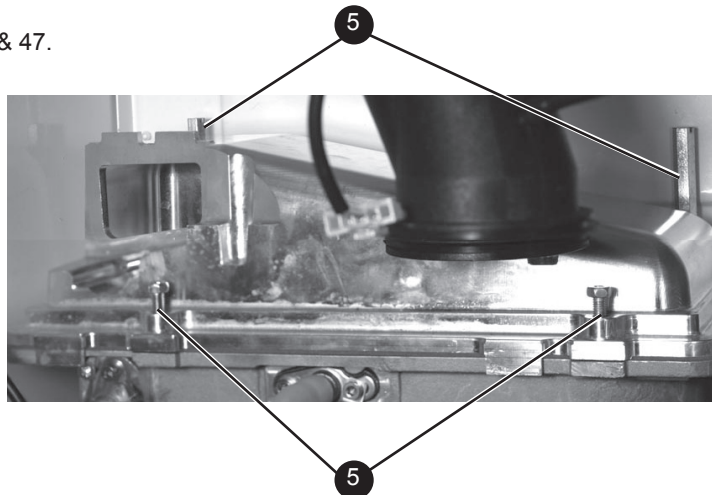
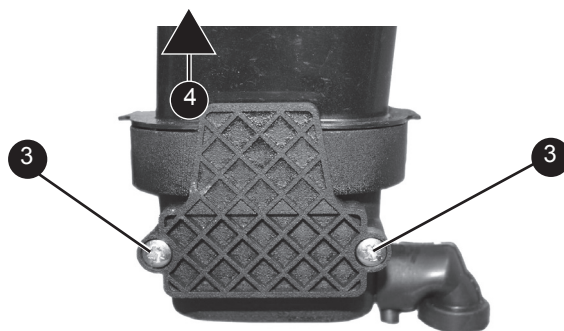

60 CONTROL & RETURN THERMISTOR RENEWAL

1. Refer to Frame 50.
2. Disconnect the electrical leads from the thermistors.
3. Unclip the flow thermistor from the flow pipe and withdraw it from the boiler.
4. Unclip the return thermistor from the return pipe and withdraw it from the boiler.
5. Reconnect the electrical lead to the new thermistors and reassemble in reverse order, ensuring that the thermistor is securely fitted to the pipe on the thermistor locator tab as shown.
6. Check the operation of the boiler. Refer to Frames 45, 46 & 47.

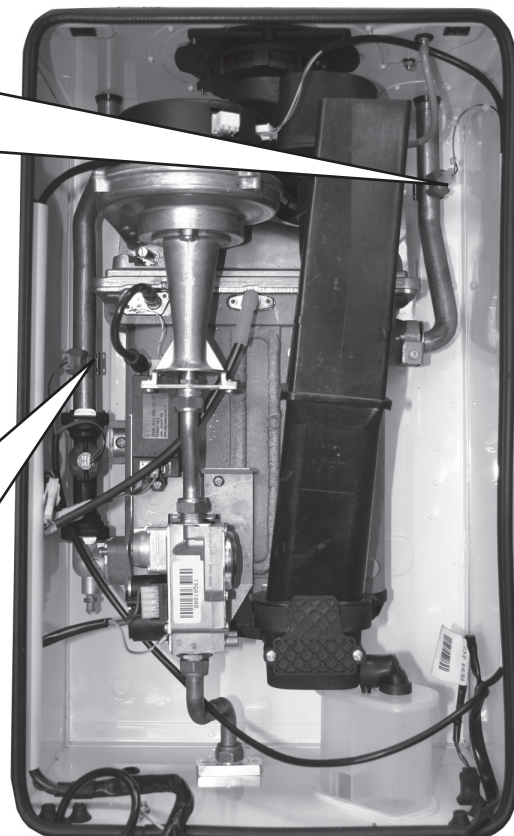
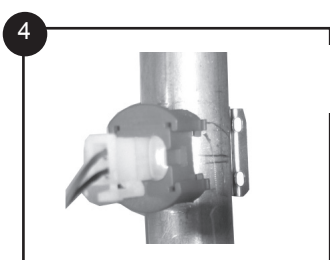
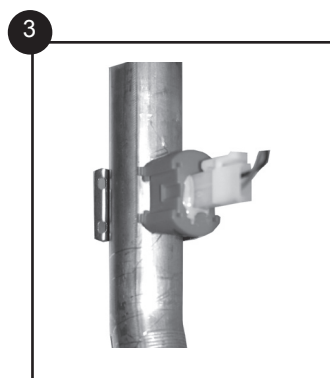
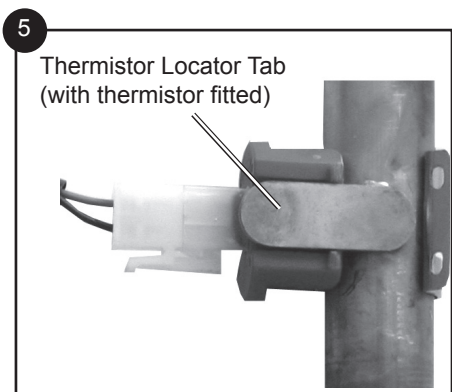

61 IGNITION ELECTRODE REPLACEMENT

1. Refer to Frame 56.
2. Remove the burner. Refer to Frame 59.
3. Unplug the ignition lead from the electrode.
4. Remove the earth lead from the ignition electrode.
5. Remove the 2 screws holding the ignition electrode to the combustion chamber.
6. Remove the electrode.
7. Fit the new ignition electrode, using the new gasket supplied. Check dimensions as shown.
8. Reassemble in reverse order.
9. Check the operation of the boiler. Refer to Frames 45, 46 & 47.

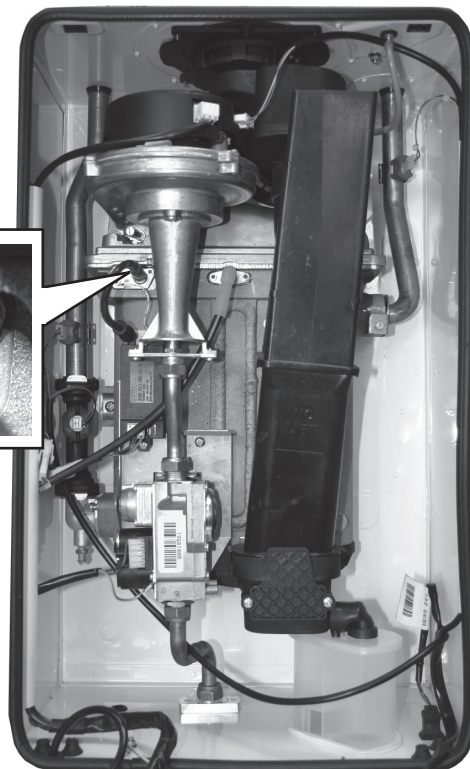
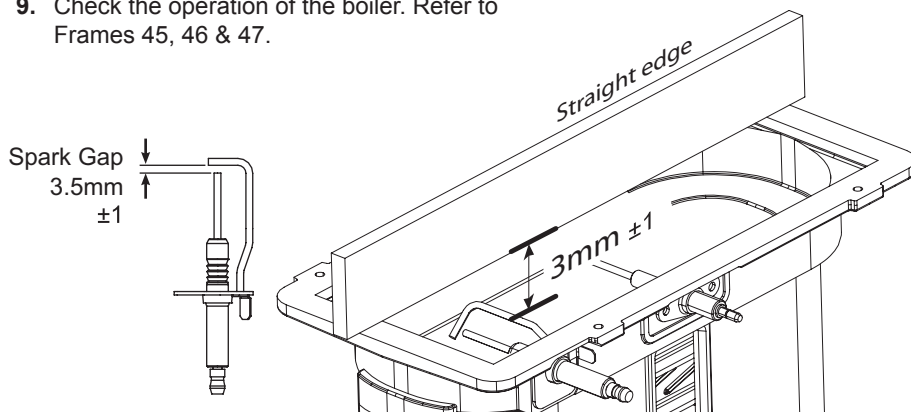
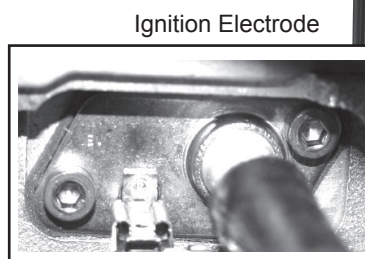

62 FLAME DETECTION ELECTRODE REPLACEMENT

1. Refer to Frame 56.
2. Remove the burner. Refer to Frame 59.
3. Unplug the flame detection lead from the electrode.
4. Remove the 2 screws retaining the detection electrode.
5. Remove the electrode.
6. Fit the new flame detection electrode (check dimension as shown below), using the new gasket supplied.
7. Reassemble in reverse order.
8. Check the operation of the boiler. Refer to Frames 45, 46 & 47.

Flame Detection Electrode

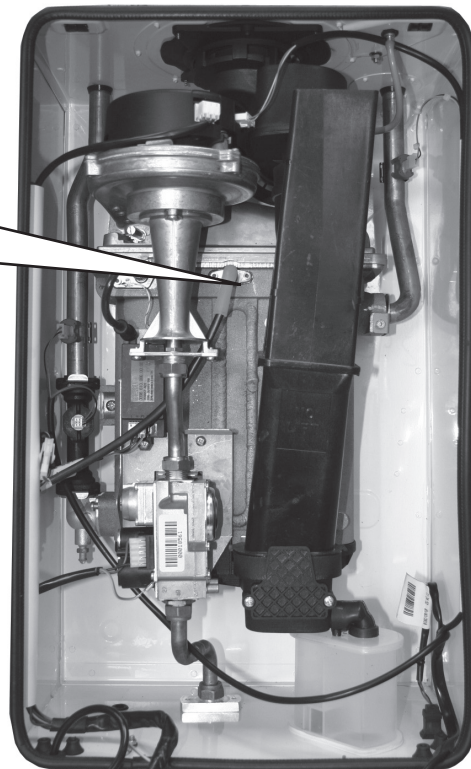
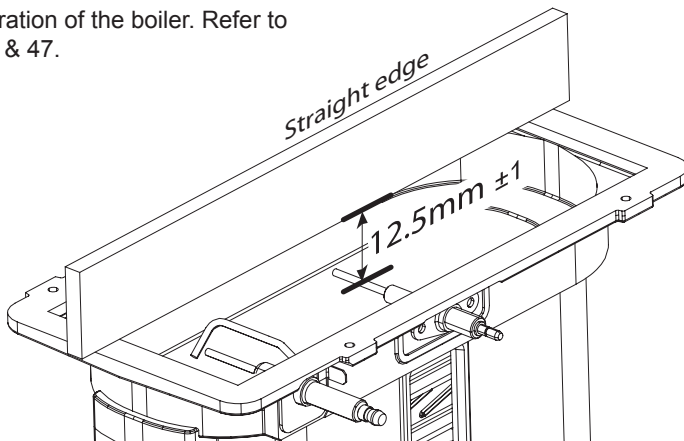
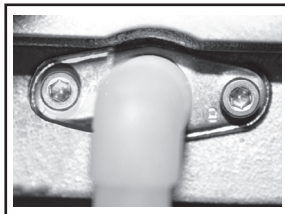

63 SPARK GENERATOR REPLACEMENT

1. Refer to Frame 56.
2. Disconnect the leads from the spark generator.
3. Remove the M5 screws securing the spark generator to the boiler chassis.
4. Fit the new spark generator and re-assemble in reverse order ensuring the two earth leads are correctly replaced.
5. Check operation of the boiler. Refer to Frames 45, 46 & 47.

Spark Generator

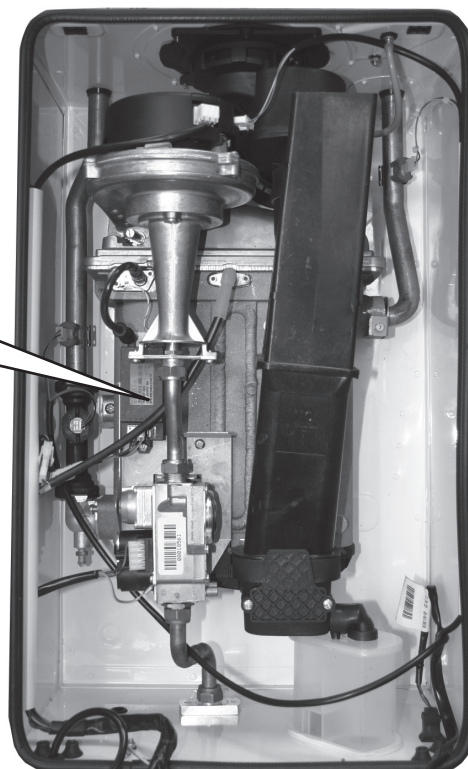
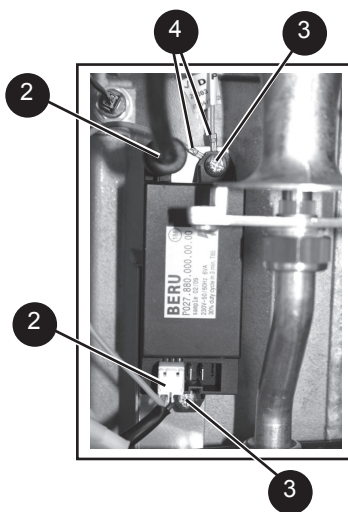

64 GAS CONTROL VALVE REPLACEMENT

1. Refer to Frame 56.
2. Unplug the electrical lead connection from the gas control valve and disconnect the earth wire.
3. Undo the union nut on the outlet of the gas control valve.
4. Undo the gas inlet pipe union at the inlet to the gas control valve.
5. Loosen the back nut retaining the valve to the bracket and withdraw the valve forwards.
6. Fit the new gas control valve ensuring the two sealing washers are in place and reconnect gas and electrical connections.
7. Check operation of the boiler. Refer to Frames 45, 46 & 47.

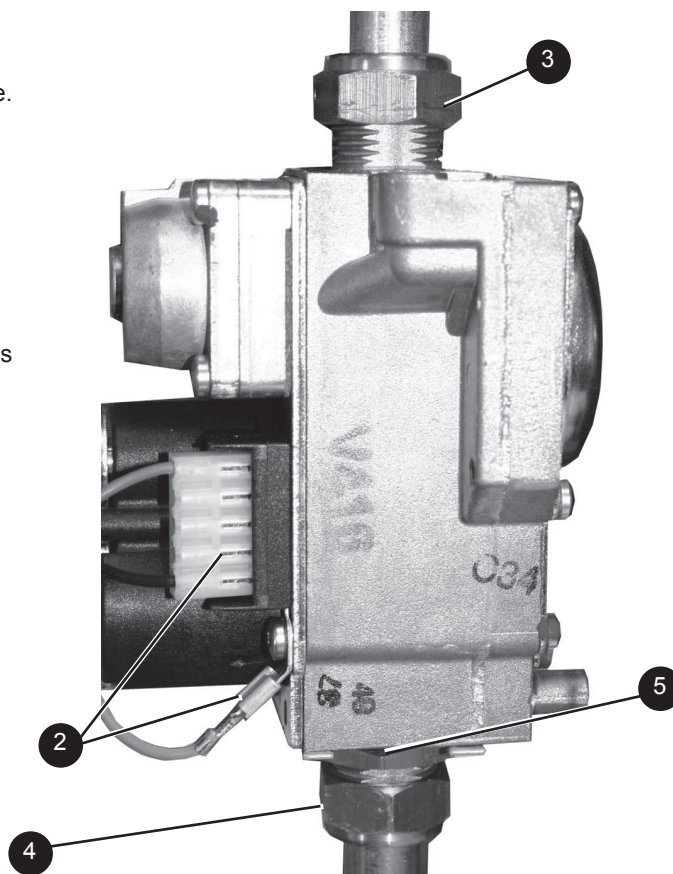

65 CONDENSATE TRAP/SIPHON REPLACEMENT

1. Refer to Frame 56.

Note: Ensure condensate trap is fully drained before removal.

2. Pull off the rubber pipe at the sump drain.
3. Disconnect the condensate drain pipe.
4. Remove the cleaning plug
5. Turn the siphon clockwise to disengage and lift to remove.
6. Reassemble in reverse order.
7. When reassembling ensure the trap is full of water.
8. Check operation of the boiler. Refer to Frames 45, 46 & 47.

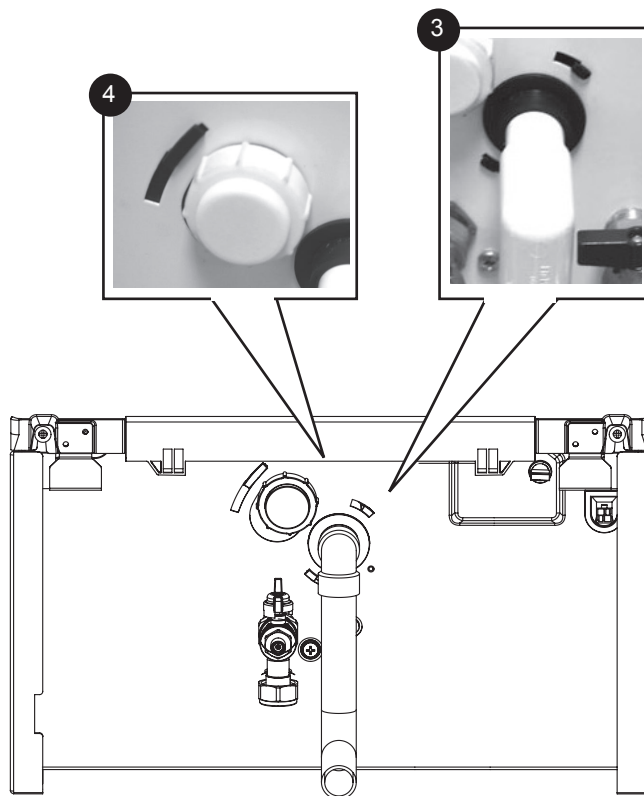
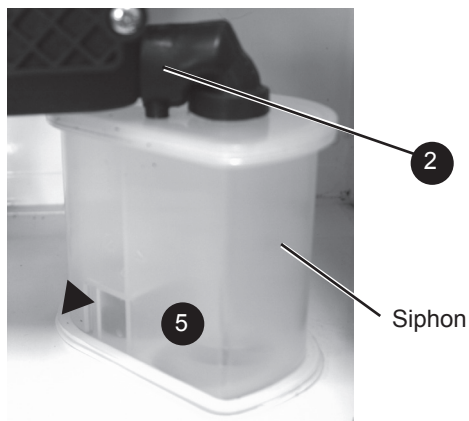

205862-10093

66 MAIN PCB REPLACEMENT

Note that production boiler PCBs are factory pre-set to operate for boiler range and output, but when ordering Primary PCB as a spare, an additional Boiler Chip Card (BCC) MUST also be purchased for your specific boiler range and output.

Note. Fit the earth strap provided with the PCB to your wrist and secure to a suitable earth on the boiler chassis.

1. Refer to Frame 56.
2. Note the control knob positions.
3. Remove the 2 screws retaining the control box cover.
4. Carefully lift the 4 retaining clips and remove control box cover.
5. Unplug all lead connections to the PCB including the ribbon cable (to facilitate ribbon cable removal, ease side clips apart and pull upwards), also where applicable, push the small plastic clip with an electrical screwdriver to facilitate plug removal.
6. Spring out the two side retaining clips and pull the PCB upwards to clear the 4 corner retaining posts.
7. Take the new Primary PCB and attach the appropriate Boiler Chip Card (BCC) to it (this should correspond to the output of the boiler: 12kW, 15kW, 18kW, 24kW or 30kW). **Note.** Ensure the correct orientation of BCC by placing "TOP" side up as shown.

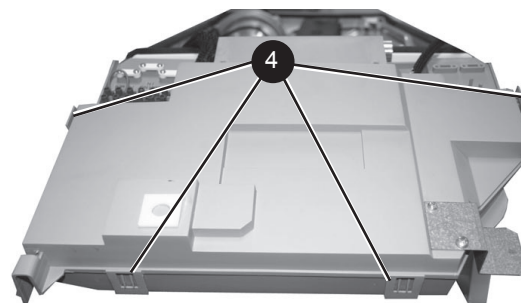

8. Re-connect all plug connections.
9. Reassemble in reverse order.
10. Turn power back on to the boiler, after a few moments the display will start alternating between "c" and "0". Turn the reset knob fully clockwise and when the display shows "-" turn the knob fully anti-clockwise IMMEDIATELY.

Finally move the knob into the required position.

11. Check operation of the boiler. Refer to Frames 45, 46 & 47.

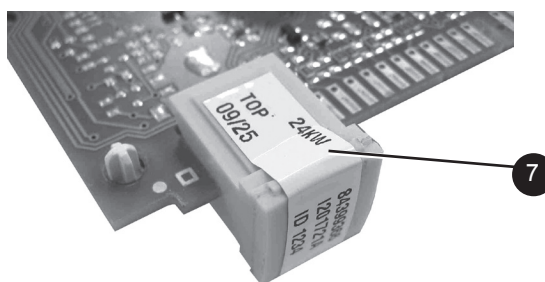
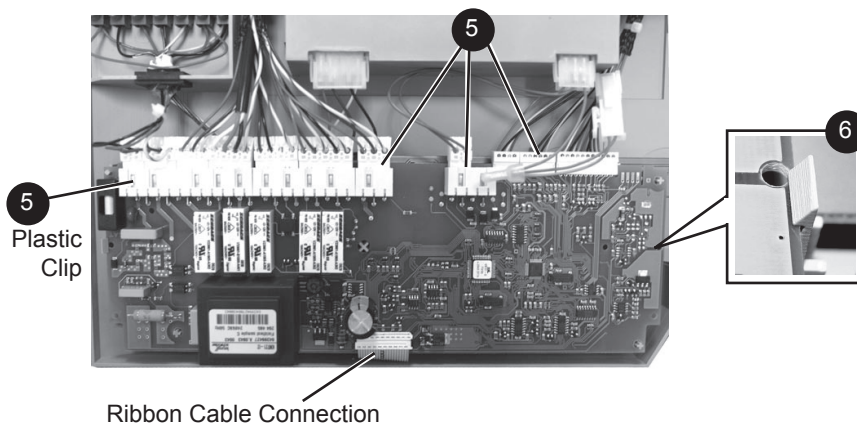

67 USER CONTROL PCB REPLACEMENT

Note. Fit the earth strap provided with the PCB to your wrist and a suitable earth on the boiler chassis.

1. Refer to Frame 56.
2. Remove the main PCB, refer to Frame 66.
3. Unclip the PCB and lift to clear the mounting posts.
4. Fit the new PCB ensuring the 2 potentiometer spindles line up with the control knobs which must be in a vertical position.
5. Reassemble in reverse order.
6. Check operation of the boiler. Refer to Frames 45, 46 & 47.

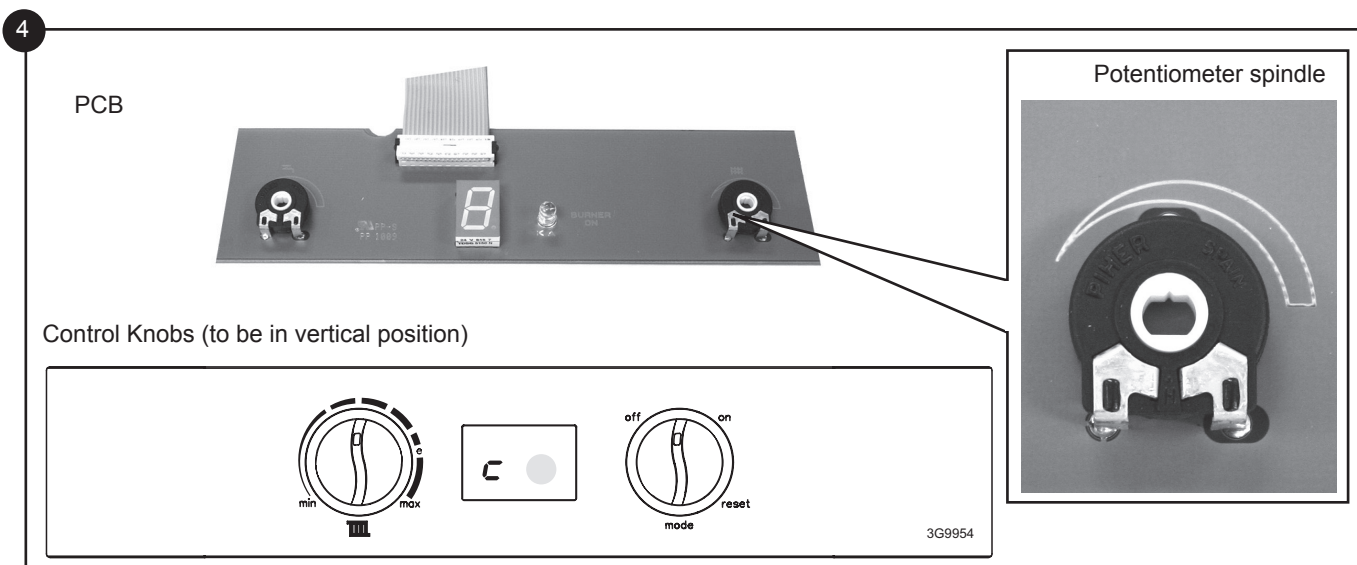
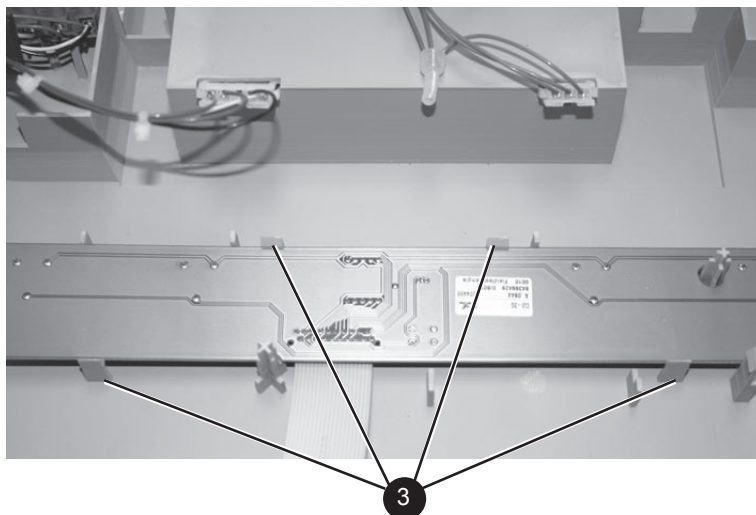

68 WATER FLOW SWITCH HEAD REPLACEMENT

1. Refer to Frame 56.
2. Drain the Boiler.
3. Pull off the electrical connection.
4. Turn the retaining collar anti-clockwise and pull the head from the housing.
5. Fit the new water flow switch head, ensuring the electrical lead connections wires point to the right as shown.
6. Re-assemble in reverse order.
7. Re-fill the boiler.
8. Check the operation of the boiler. Refer to Frames 45, 46 & 47.

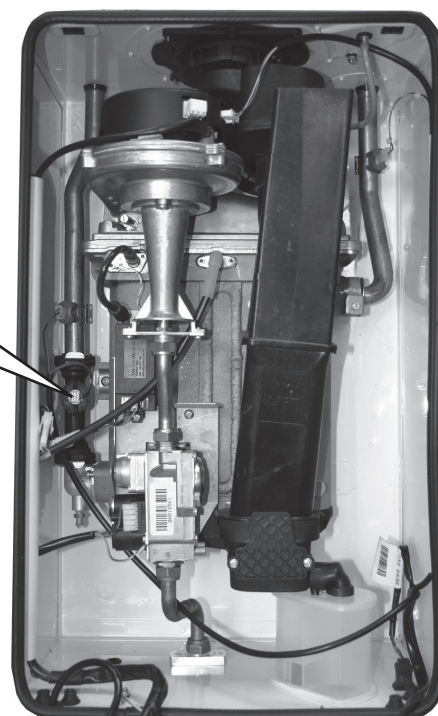
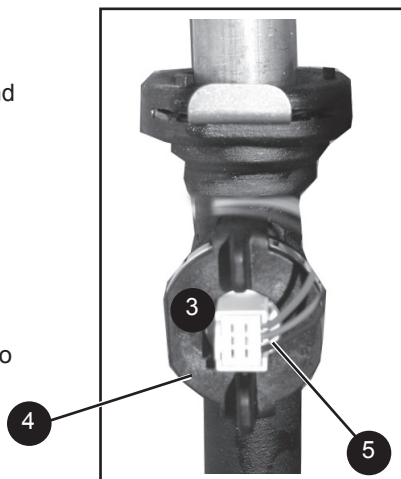

SERVICING

69 HEAT ENGINE RENEWAL - Refer also to Frame 10 - 'Boiler Exploded View'

Note. To remove the flow and return pipe connections from the heat exchanger, it may be necessary to cut the pipes above the boiler.

IMPORTANT

Before starting the removal procedure, protect the gas and electrical controls with a waterproof sheet or plastic bag.

1. Refer to Frame 56.
2. Drain the boiler from the drain point provided.
3. Remove the fan / venturi assembly and place on one side. Refer to frame 57.
4. Remove the burner and place on one side. Refer to Frame 59.
5. Remove the ignition and detection electrodes. Refer to Frames 61 and 62.
6. Remove the spark generator. Refer to Frame 63.
7. Remove the gas valve. Refer to Frame 64.
8. Remove the 2 M5 screws retaining the gas valve mounting bracket and transfer bracket to the new heat exchanger.
9. Pull the bottom clip, retaining the water flow switch housing, forward to remove.
10. Lift the housing/return pipe assembly upwards to disengage from the heat exchanger return pipe elbow.
11. Remove the screw retaining the flow pipe bracket and remove the bracket from its rear retention slot.
12. Pull the flow pipe to the right to disengage from the heat exchanger.
13. Remove the condensate rubber pipe. Refer to Frame 65.
14. Remove the LH heat exchanger fixing screw.
15. Pull the heat exchanger to the left to disengage the rear retention pegs and remove the heat exchanger.
16. Reassemble in reverse order, ensuring the heat exchanger is correctly positioned. Replace any new 'o' rings supplied with new heat exchanger and replacing gaskets or seals if any sign of damage is evident.

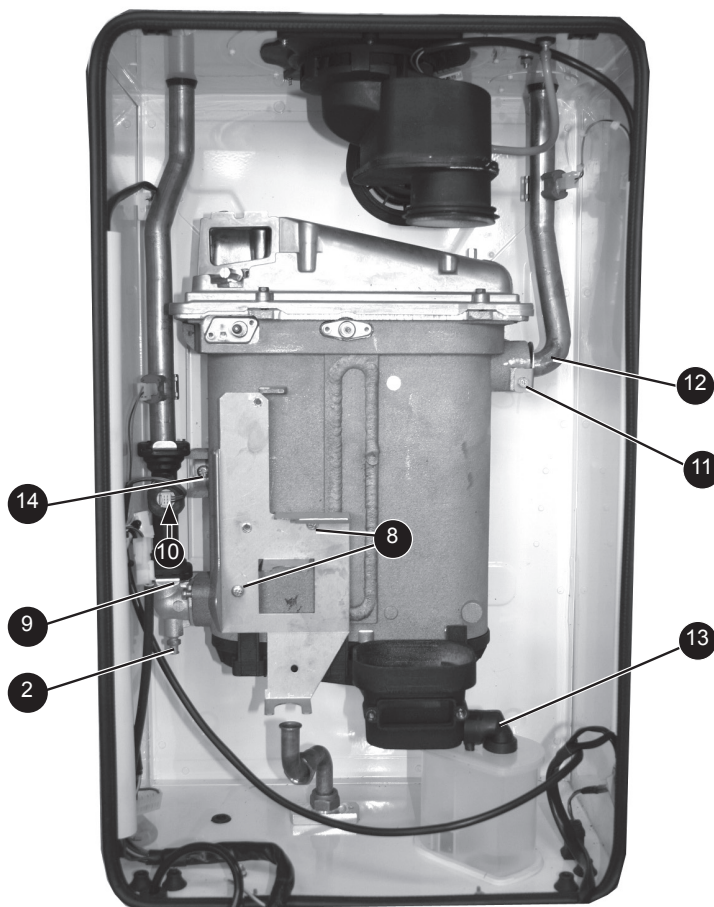

17. Ensure the trap/siphon is filled with water. Refer to Frame 65.
18. Refill the boiler.
19. Check operation of the boiler. Refer to Frames 45, 46 & 47.

70 BOILER SEALING PANEL SEAL REPLACEMENT

1. Refer to Frame 56.
2. Remove the old seal from the casing and thoroughly clean the casing surfaces.
3. Fit the new seal, ensuring the bottom joint provides an air tight seal.
5. Reassemble in reverse order.
6. Check operation of the boiler. Refer to Frames 45, 46 & 47.

Note. Ensure that the boiler front panel is correctly sealed, compressing the seal to make an airtight joint.

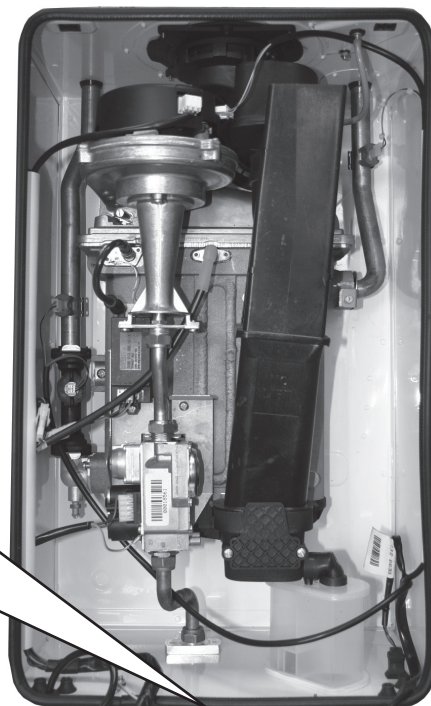
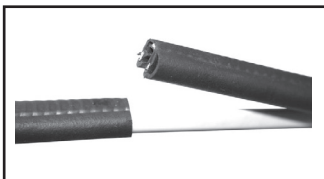

FAULT FINDING

71 FAULT FINDING CHART MAIN MENU

In order to assist fault finding the boiler has a 7 segment display. The key to the display codes is as follows:

| | |
|-------------------------|---|
| ALTERNATING 'L' and '1' | GO TO FRAME 72 - FLOW TEMPERATURE OVERHEAT LOCKOUT |
| ALTERNATING 'L' and '2' | GO TO FRAME 73 - IGNITION LOCKOUT |
| ALTERNATING 'L' and '5' | 5 RESETS WITHIN 15 MINS - TURN POWER OFF AND ON |
| ALTERNATING 'L' and '6' | GO TO FRAME 74 - FALSE FLAME LOCKOUT |
| ALTERNATING 'F' and '2' | GO TO FRAME 75 - FLAME LOSS |
| ALTERNATING 'F' and '3' | GO TO FRAME 76 - FAN FAULT |
| ALTERNATING 'F' and '4' | GO TO FRAME 77 - FLOW THERMISTOR FAULT |
| ALTERNATING 'F' and '5' | GO TO FRAME 78 - RETURN THERMISTOR FAULT |
| ALTERNATING 'F' and '6' | GO TO FRAME 79 - OUTSIDE SENSOR FAULT |
| ALTERNATING 'F' and '7' | LOW MAINS VOLTAGE - CONTACT ELECTRICITY PROVIDER |
| ALTERNATING 'F' and '9' | PCB FAULT - **REPLACE PCB |
| ALTERNATING 'F' and 'A' | GO TO FRAME 80 - FLOW/RETURN REVERSED |
| ALTERNATING 'F' and 'd' | GO TO FRAME 81 - NO WATER FLOW |
| ALTERNATING 'F' and '0' | BCC NOT FITTED |
| ALTERNATING 'c' and '2' | GO TO FRAME 82 - BCC FAULT (BOILER CHIP CARD) |
| ALTERNATING 'c' and '0' | RESET BOILER |
| NO CH | GO TO FRAME 83 |
| NO DHW | GO TO FRAME 84 |
| NO DISPLAY | GO TO FRAME 85 |

Note that production boiler PCBs are factory pre-set to operate for boiler range and output, but when ordering Primary PCB as a spare, an additional Boiler Chip Card (BCC) MUST also be purchased for your specific boiler range and output.

**If PCB replaced as a spare ensure that the BCC (boiler chip card - small plastic part) is fitted to the PCB otherwise replace PCB.

RESET PROCEDURE - To reset boiler, turn mode knob to reset position and immediately turn knob back to required setting.

FAULT FINDING

72 ALTERNATING 'L' AND '1' - FLOW TEMPERATURE OVERHEAT LOCKOUT

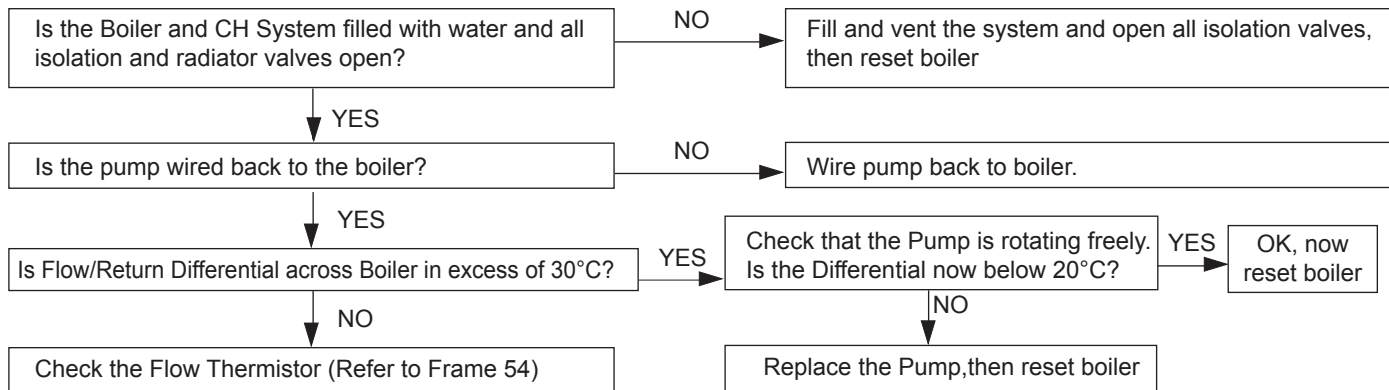

RESET PROCEDURE - To reset boiler, turn mode knob to reset position and immediately turn knob back to required setting.

73 ALTERNATING 'L' AND '2' - IGNITION LOCKOUT

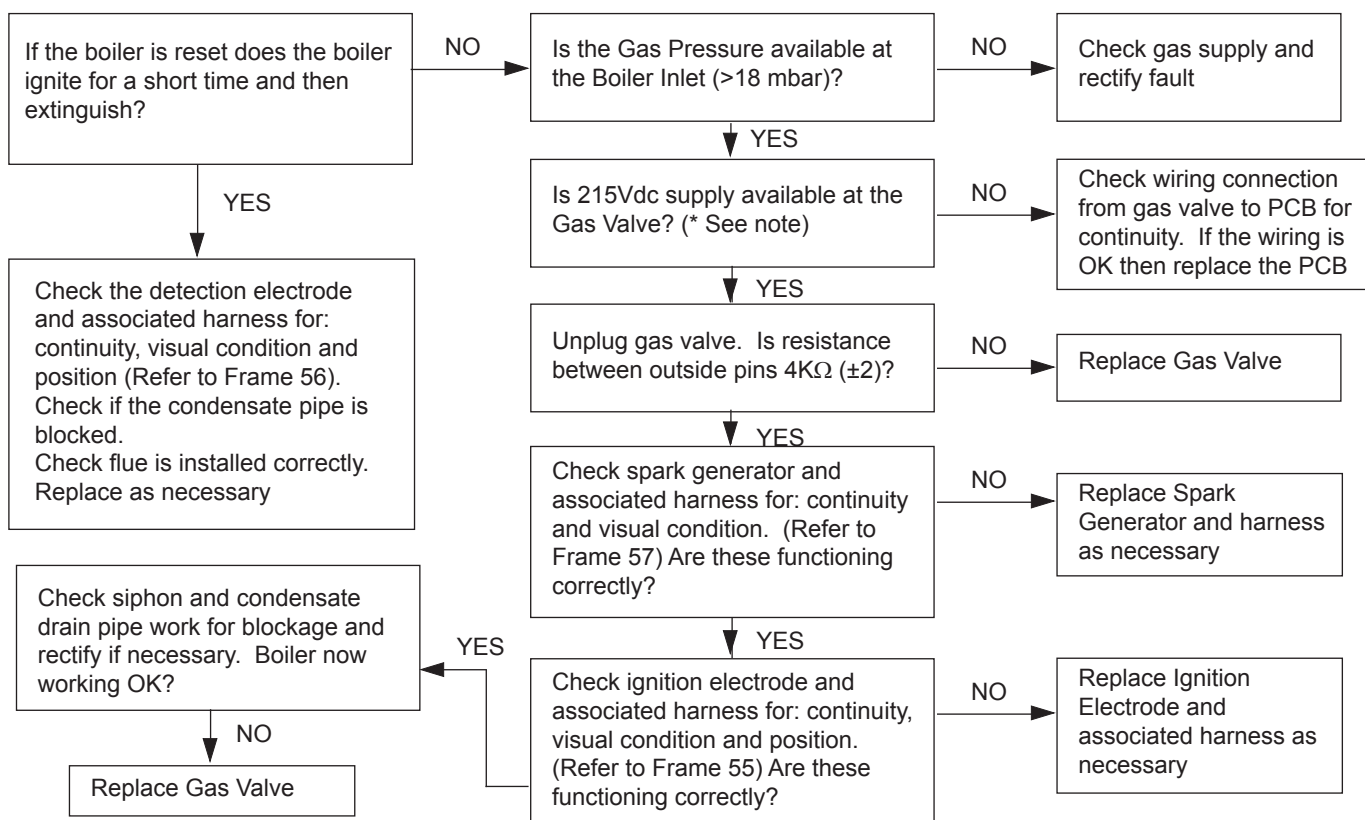

** Note: due to the wave form of the rectified voltage, the reading will vary depending on the type of meter used to measure the value. In general terms a reading greater than 150V indicates that the correct voltage is supplied to the gas valve.*

RESET PROCEDURE - To reset boiler, turn mode knob to reset position and immediately turn knob back to required setting.

74 ALTERNATING 'L' AND '6' - FALSE FLAME LOCKOUT

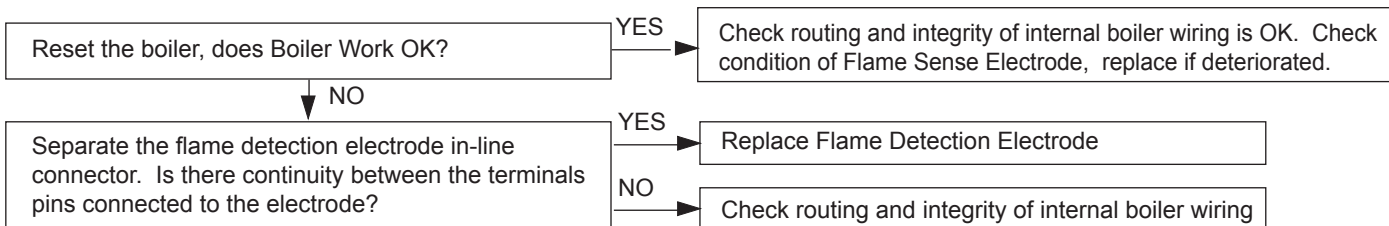

RESET PROCEDURE - To reset boiler, turn mode knob to reset position and immediately turn knob back to required setting.

FAULT FINDING

75 ALTERNATING 'F' AND '2' - FLAME LOSS

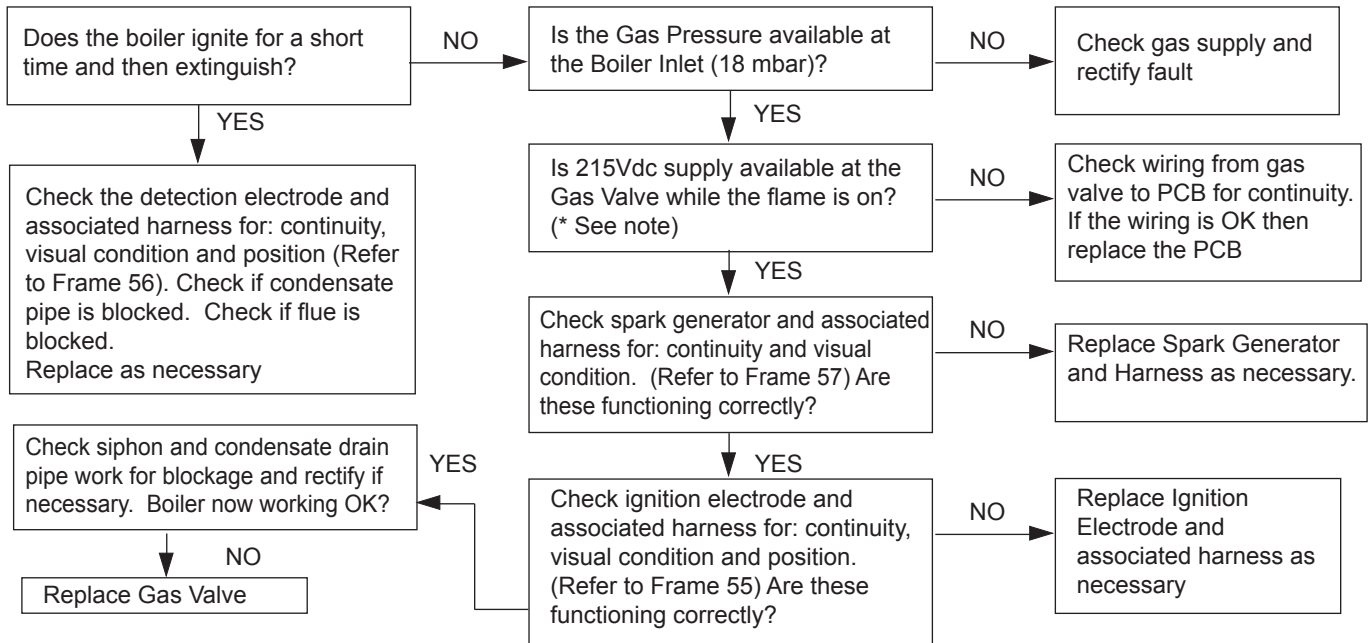

** Note: due to the wave form of the rectified voltage, the reading will vary depending on the type of meter used to measure the value. In general terms a reading greater than 150V indicates that the correct voltage is supplied to the gas valve.*

76 ALTERNATING 'F' AND '3' - FAN FAULT

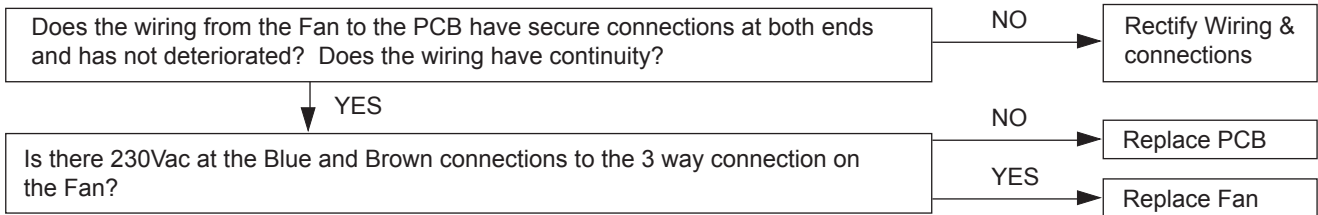

77 ALTERNATING 'F' AND '4' - FLOW THERMISTOR FAULT

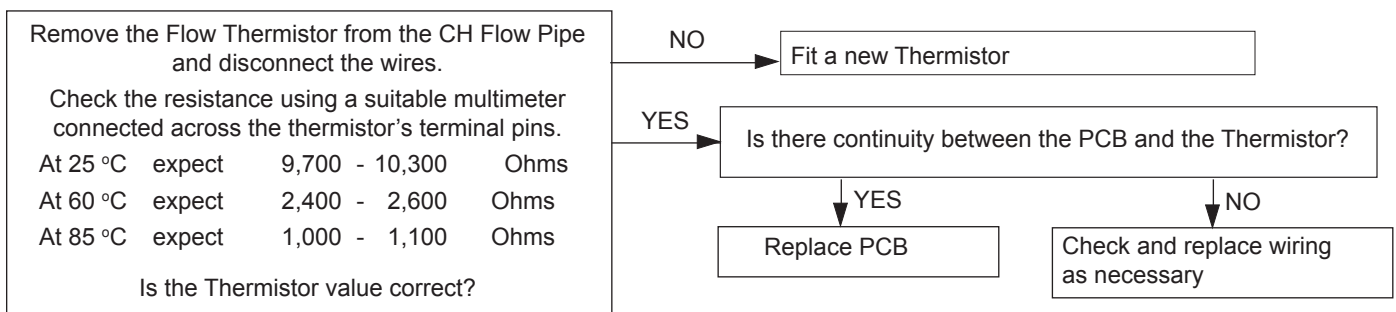

78 ALTERNATING 'F' AND '5' - RETURN THERMISTOR FAULT

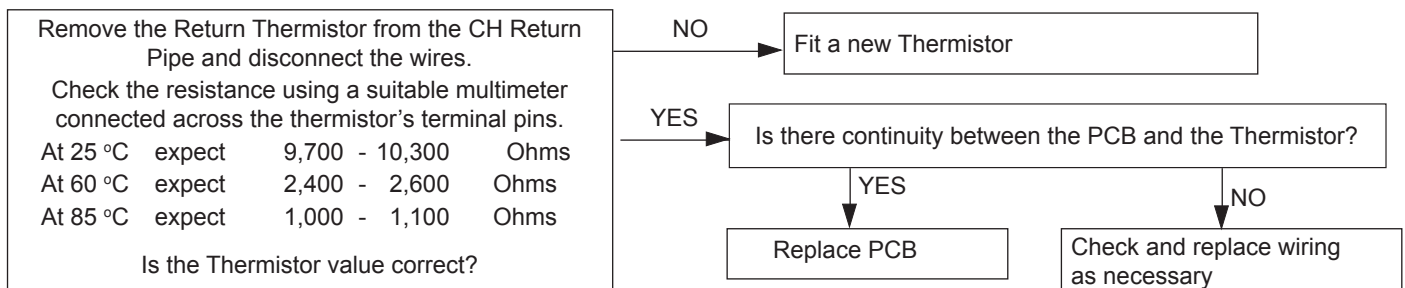

83 NO CH OPERATION

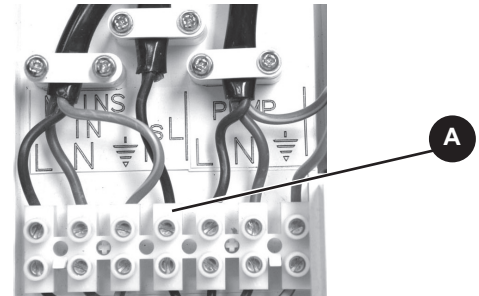
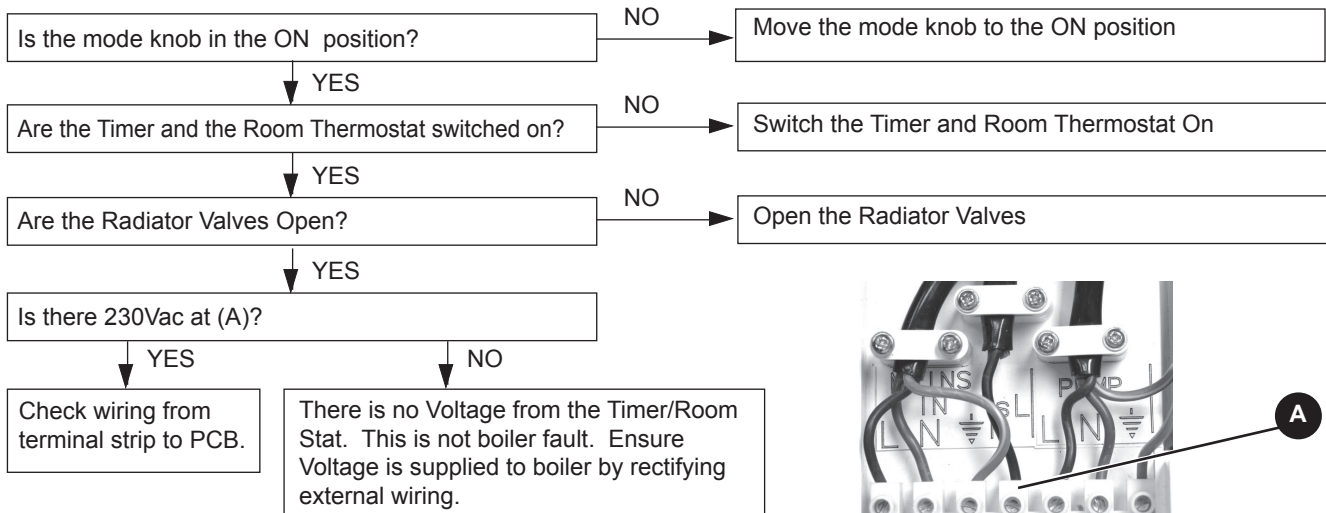

84 NO DHW

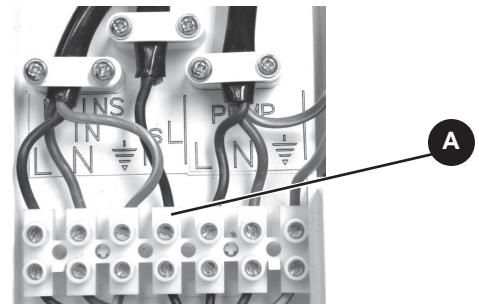
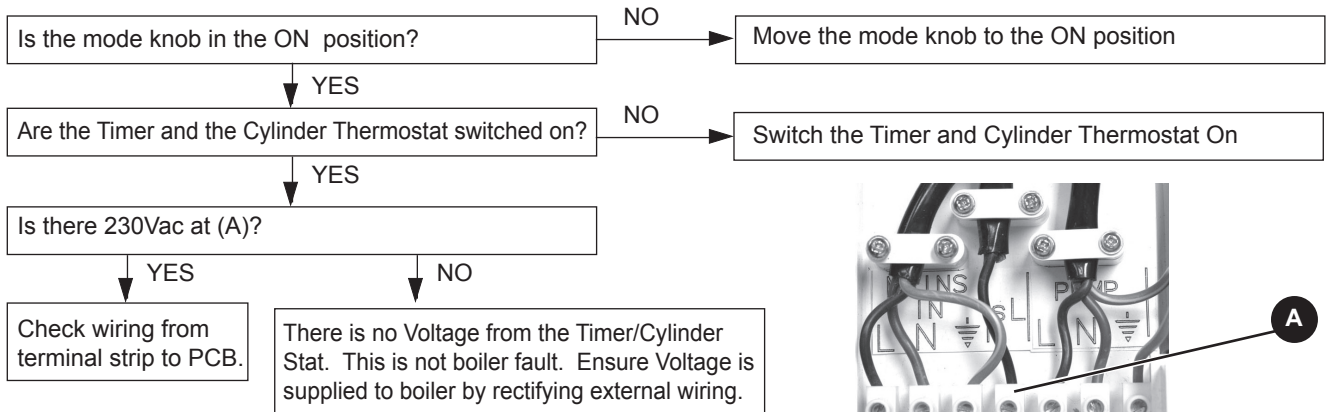

85 NO DISPLAY

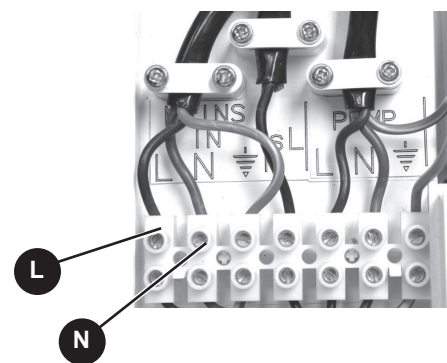
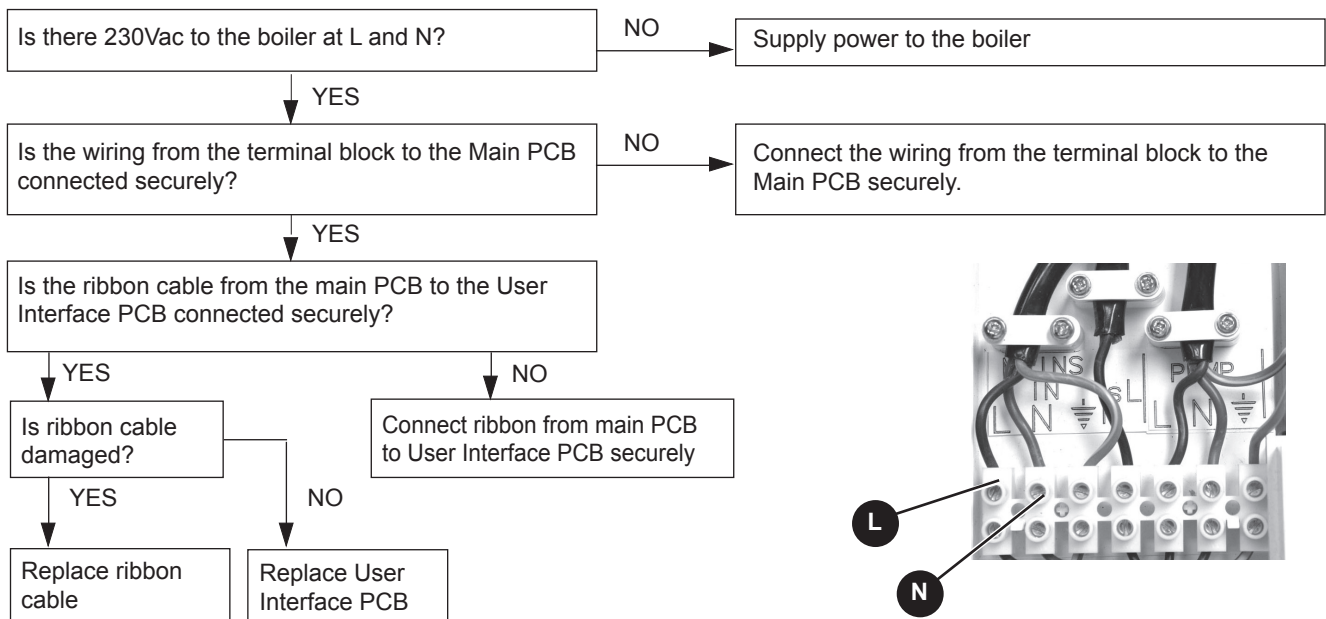

SHORT LIST OF PARTS

The following are parts commonly required due to damage or expendability. Their failure or absence is likely to affect safety or performance of this appliance.

The list is extracted from the British Gas List of Parts, which contains all available spare parts.

The full list is held by British Gas Services, Ideal Stelrad Group distributors and merchants.

When replacing any part on this appliance use only spare parts that you can be assured conform to the safety and performance specification that we require. Do not use reconditioned or copy parts that have not been clearly authorised by Ideal.

When ordering spares please quote:

1. Boiler model
2. Appliance G.C. No.
3. Description.
4. Quantity.
5. Product number.

***** **FOR DIAGRAMS REFER TO FRAME 10 - BOILER ASSEMBLY** *****

| Key No. | G.C. Part No. | Description | Qty./boiler | Product Number |
|---------|---------------|----------------------------------|-----------------|----------------|
| 104 | | Flow Sensor | 1 | 175979 |
| 205 | | Gas Valve kit | 1 | 175562 |
| 211 | | Injector & Housing | 12, 15, 18 & 24 | 175566 |
| | | Injector & Housing | 30 | 175613 |
| 215 | | Fan Kit | 1 | 175569 |
| 217 | | Burner | 1 | 175571 |
| 229 | | Siphon Trap Kit | 1 | 175583 |
| 232 | | Turret Manifold Gasket | 1 | 175620 |
| 302 | | Primary PCB* | 1 | 175935 |
| 302a | | Boiler Chip Card (BCC) | 12 | 175955 |
| | | Boiler Chip Card (BCC) | 15 | 175956 |
| | | Boiler Chip Card (BCC) | 18 | 175957 |
| | | Boiler Chip Card (BCC) | 24 | 175958 |
| | | Boiler Chip Card (BCC) | 30 | 175959 |
| 303 | | CUI Board | 1 | 175978 |
| 304 | | Control Thermistor (Flow/Return) | 2 | 175985 |
| 306 | | Ignition Electrode Kit | 1 | 175591 |
| 307 | | Detection Electrode Kit | 1 | 175592 |
| 308 | | Spark Generator | 1 | 175593 |
| 313 | | Ignition lead | 1 | 175598 |
| 320 | | Detection Lead | 1 | 175604 |
| 328 | | Fuse - PCB | 1 | 175627 |
| 403 | | Heat Engine Gasket Kit | 1 | 175618 |
| 504 | | Front Casing Panel | 1 | 176066 |

*Note that production boiler PCBs are factory pre-set to operate for boiler range and output, but when ordering Primary PCB as a spare, an additional Boiler Chip Card (BCC) MUST also be purchased for your specific boiler range and output.

Code Of Practice

For the installation, commissioning and servicing of domestic heating and hot water products

Benchmark places responsibilities on both manufacturers and installers.* The purpose is to ensure that customers** are provided with the correct equipment for their needs, that it is installed, commissioned and serviced in accordance with the manufacturer's instructions by competent persons and that it meets the requirements of the appropriate Building Regulations. Installers are required to carry out work in accordance with the following:

Standards of Work

- Be competent and qualified to undertake the work required.
- Install, commission, service and use products in accordance with the manufacturer's instructions provided.
- Ensure that where there is responsibility for design work, the installation is correctly sized and fit for purpose.
- Meet the requirements of the appropriate Building Regulations. Where this involves notifiable work be a member of a Competent Persons Scheme or confirm that the customer has notified Local Authority Building Control (LABC), prior to work commencing.
- Complete all relevant sections of the Benchmark Checklist/Service Record when carrying out commissioning or servicing of a product or system.
- Ensure that the product or system is left in a safe condition and, whenever possible, in good working order.
- Highlight to the customer any remedial or improvement work identified during the course of commissioning or servicing work.
- Refer to the manufacturer's helpline where assistance is needed.
- Report product faults and concerns to the manufacturer in a timely manner.

Customer Service

- Show the customer any identity card that is relevant to the work being carried out prior to commencement or on request.
- Give a full and clear explanation/demonstration of the product or system and its operation to the customer.
- Hand over the manufacturer's instructions, including the Benchmark Checklist, to the customer on completion of an installation.
- Obtain the customer's signature, on the Benchmark Checklist, to confirm satisfactory demonstration and receipt of manufacturer's instructions.
- Advise the customer that regular product servicing is needed, in line with manufacturers' recommendations, to ensure that safety and efficiency is maintained.
- Respond promptly to calls from a customer following completion of work, providing advice and assistance by phone and, if necessary, visiting the customer.
- Rectify any installation problems at no cost to the customer during the installer's guarantee period.



*The use of the word "installer" is not limited to installation itself and covers those carrying out installation, commissioning and/or servicing of heating and hot water products, or the use of supporting products (such as water treatment or test equipment).

**Customer includes householders, landlords and tenants.

For additional fault finding advice please visit Ideal's website

www.idealheating.com

Technical Training

The Ideal Technical Training Centre offers a series of first class training courses for domestic, commercial and industrial heating installers, engineers and system specifiers. For details of courses please ring:..... 01482 498 432



The code of practice for the installation, commissioning & servicing of central heating systems



Manufactured under an ISO 9001 registered quality management system

FM 59915

Ideal Boilers Ltd., P.O. Box 103, National Ave, Kingston upon Hull, HU5 4JN. Telephone: 01482 492 251 Fax: 01482 448 858. Registration No. London 322 137.

Ideal Stelrad Group pursues a policy of continuing improvement in the design and performance of its products. The right is therefore reserved to vary specification without notice.



Ideal Stelrad Group

Ideal Installer/Technical Helpline: 01482 498 663

www.idealheating.com