

# THE IDEAL USERS GUIDE

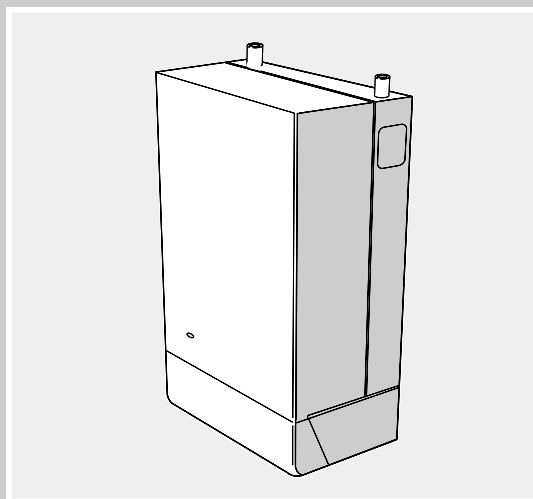

*classic*

the wall hung boiler

Wall mounted, fanned,  
balanced flue gas boilers

**Classic**  
**LXFF 230 - 280**  
**FF 230 - 2 100**

**i** BOILERS  
*Ideal*



# CLASSIC LXFF & FF (Natural Gas Models Only)

## Deluxe

Classic LXFF 230 .....	G.C. No. 41 387 24
Classic LXFF 240 .....	G.C. No. 41 387 25
Classic LXFF 250 .....	G.C. No. 41 387 26
Classic LXFF 260 .....	G.C. No. 41 387 27
Classic LXFF 270 .....	G.C. No. 41 387 28
Classic LXFF 280 .....	G.C. No. 41 387 29

## Standard

Classic FF 230 .....	G.C. No. 41 387 01
Classic FF 240 .....	G.C. No. 41 387 02
Classic FF 250 .....	G.C. No. 41 387 03
Classic FF 260 .....	G.C. No. 41 387 04
Classic FF 270 .....	G.C. No. 41 387 05
Classic FF 280 .....	G.C. No. 41 387 06
Classic FF 2 100 .....	G.C. No. 41 349 71

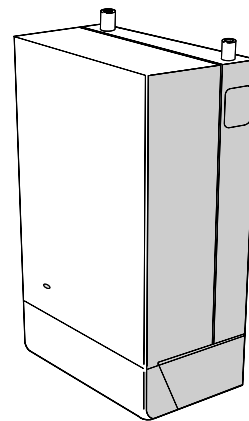
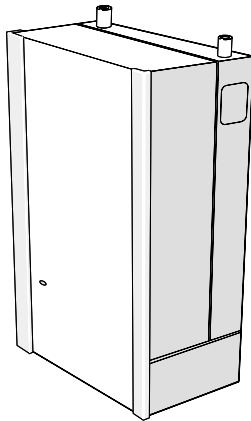

## Introduction

It is essential that the instructions in this booklet are strictly followed, for safe and economic operation of the boiler.

### Gas safety (Installation & Use) Regulations 1994, amendments 1996 or rules in force.

In your own interest, and that of safety, it is the law that this boiler must be installed by a registered installer, in accordance with all national and local regulations.

## Electricity Supply

**This appliance must be efficiently earthed.**

Supply: 230 V ~ 50 Hz. The fusing should be 3A.

Connection must be made in a way that allows complete isolation of the electrical supply such as a double pole switch having a 3mm (1/8") contact separation in both poles, or a plug and socket, serving only the boiler and system controls. The means of isolation must be accessible to the user after installation.

## Important notes

- a. This appliance must not be operated without the casing correctly fitted and forming an adequate seal.
- b. If the boiler is installed in a compartment then the compartment MUST NOT be used for storage purposes.

- c. The ventilation provided for the boiler during installation MUST NOT be blocked, and a check should be made periodically that the ventilation areas are free from any obstruction.
- d. If it is known or suspected that a fault exists on the boiler then it MUST NOT be used until the fault has been corrected by a CORGI registered installer.
- e. Inflammable materials must not be placed in close proximity to the appliance. Materials giving off flammable vapours must not be stored in the same room as the appliance.
- f. Under NO circumstances should any of the sealed components on this appliance be used incorrectly or tampered with.

## Minimum clearances

A clearance of 533mm (21") MUST be available at the front of the boiler for servicing.

The minimum clearances given below MUST be complied with in order to maintain the safe running of the boiler and to facilitate servicing.

<b>Above the boiler</b>	100 mm	(4")
<b>At each side of the boiler</b>	5 mm	(1/4")
<b>Underneath the boiler</b>	100 mm	(4")
<b>In front of the boiler</b>	450 mm	(17 3/4")

**CAUTION. To avoid the possibility of injury during the installation, servicing or cleaning of this appliance care should be taken when handling edges of sheet steel components**

## To light the boiler. Refer to Frame 1

- CHECK THAT THE ELECTRICITY SUPPLY TO THE BOILER IS OFF.
- Deluxe Model (LX)** - Lift the glass fascia and support it with the sliding catch.  
**Standard Model** - Open the controls access door by hinging downwards.
- Ensure that the gas inlet cock (B) is OPEN.
- Press the overheat reset button (D), located as shown in Frame 1.
- Ensure that the mains on/off switch (E) is in the OFF position.
- Switch ON the electricity supply to the boiler. Check that all external controls, e.g. room thermostat etc., are ON.
- Turn the boiler thermostat knob (C) to position 6 and the mains on/off switch (E) to ON. After about 15 seconds the boiler will light automatically - this can be viewed through the sight glass (A).  
Set the boiler thermostat to the desired position.
- Deluxe Model (LX)** - Lower the glass fascia after pushing in the sliding catch.  
**Standard Model** - Close the controls access door.

**Standard Model** - Close the controls access door.

In **winter conditions**, i.e. central heating and domestic hot water, the thermostat should be set at position 5 or 6.

For **summer conditions**, i.e. domestic hot water only, the thermostat should be set at position 3.

These settings, however, are offered for general guidance only and other settings may be found preferable, dependent upon the type of system installed or as recommended by the installer.

Approximate flow temperatures for the boiler thermostat settings are:

Knob Setting	Flow Temperature	
	°C	°F
1	56	133
2	61	142
3	66	152
4	72	161
5	77	170
6	82	180

## 1 BOILER CONTROLS

**Deluxe Model (LX)**

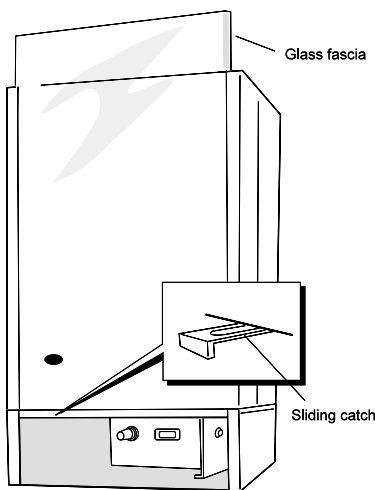

**Standard Model**

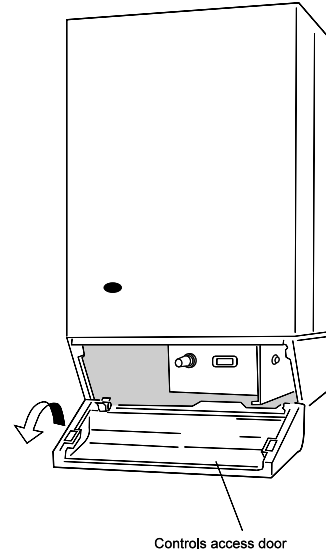

View inside boiler controls area

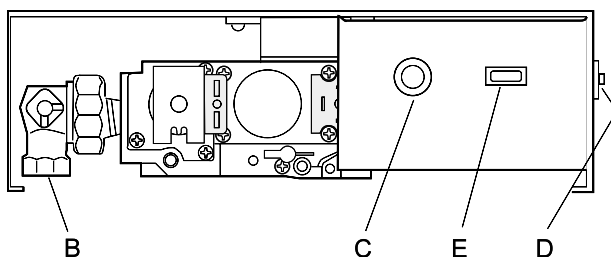

### LEGEND

- A Sightglass
- B Gas inlet cock (shown in the OPEN position)
- C Thermostat knob
- D Overheat thermostat reset button
- E Mains on/off switch

**NOTE TO THE INSTALLER: LEAVE THESE INSTRUCTIONS ADJACENT TO THE GAS METER**

## ***To shut down the boiler***

### **1. For short periods**

Turn the boiler on/off switch (E) to OFF.  
When heating is again required, restore the switch to ON.

### **2. For longer periods**

Turn the boiler ON/OFF switch (E) to OFF.  
Switch the electricity supply to OFF.

## ***Frost protection***

If no frost protection is provided and frost is likely during a short absence from home, leave the heating controls at a reduced temperature setting.

For longer periods, the entire system should be drained - including the domestic water supply. If the system includes a frost thermostat then, during cold weather, the boiler should be turned OFF at the time switch(es) ONLY. The mains supply should be left switched ON, with the boiler thermostat left in the normal running position.

## ***Boiler Overheat Thermostat***

**(Fitted for sealed systems only)**

The boiler is fitted with a safety 'cutout' thermostat. This will shut down the boiler in the event of overheating. Should this occur allow the boiler to cool, press the reset button (D) then relight as detailed in steps 1-8 in 'To light the boiler'.

*If the cutout condition still persists turn off the boiler and consult a CORGI registered installer.*

## ***Control of water temperature***

1. Adjust the boiler thermostat (C) to give the required temperature for central heating.
2. The boiler thermostat automatically switches the main burner OFF and ON to maintain the selected temperature.

## ***To relight the boiler***

Repeat the procedure 1 - 8, detailed in 'To light the boiler'.

## ***Loss of system water pressure***

***Standard boilers fitted with Classic Sealed System Units only***

If the red arrow on the unit pressure gauge is set above zero and the system pressure is seen to fall below this value over a period of time then a water leak is indicated. In this event a CORGI registered installer should be consulted.

**DO NOT OPERATE THE BOILER IF THE PRESSURE HAS REDUCED TO ZERO FROM THE ORIGINAL SETTING.**

## ***Escape of gas***

Should a gas leak be suspected, contact your local gas supplier without delay.

***Do NOT search for gas leaks with a naked flame.***

## ***Cleaning***

For normal cleaning simply dust with a dry cloth.  
To remove stubborn marks and stains, wipe with a damp cloth and finish off with a dry cloth.

**Do NOT use abrasive cleaning materials.**

## ***Maintenance***

The appliance should be serviced at least once a year by a CORGI registered installer.



***The code of practice for the installation, commissioning & servicing of central heating systems***

Caradon Plumbing Limited is a member of the Benchmark initiative and fully supports the aims of the programme. Benchmark has been introduced to improve the standards of installation and commissioning of central heating systems in the UK and to encourage the regular servicing of all central heating systems to ensure safety and efficiency.



**THIS SYMBOL IS YOUR ASSURANCE OF QUALITY**

These appliances are designed for use with Natural Gas only. They have been tested and conform with the provisions of BS. 6332 and BS. 5258.



**CERTIFIED PRODUCT**  
Manufactured under a BS EN ISO 9001:1994 Quality System accepted by BSI.



LXFF.87/AQ/220  
LXRS.87/AQ/221  
FF.87/AP/107  
RS.87/AP/108

Natural Gas appliances are service listed by British Gas

**Caradon Plumbing Solutions** pursues a policy of continuing improvement in the design and performance of its products. The right is therefore reserved to vary specification without notice.

September 1999

UIN 111 498 A06

**Caradon Plumbing Solutions** P.O. Box 103, National Ave, Kingston upon Hull, HU5 4JN. Telephone: 01482 492 251 Fax: 01482 448 858. Registration No. London 322 137. Registered Office: National Avenue, Kingston upon Hull, HU5 4JN. *A subsidiary of Caradon p.l.c*

***i* Ideal** BOILERS

***Ideal Consumer Helpline: 01482 498 660***

## YOUR FEEDBACK

*and your chance to win a free boiler*

At Ideal we've been leaders in the design and engineering of robust and reliable boilers for over 90 years. We want to continue as leaders by listening to your suggestions for how to improve our boilers and our service. We will be giving away a free boiler for the five best ideas every year (to be selected by our Technical Director). Please complete this form, using extra sheets if required, and post it or fax it to us on 01482 498699.

### **Boiler details**

Model / Size (e.g. Classic RS 230, Mexico CF 3/60 etc. Details on control panel door)

Date of Installation

### **Installer details**

Name

Address

Post Code

Telephone (Please include STD code)

### **How I would improve this boiler:**

### **My general comments for Ideal:**

**Caradon**   
**Plumbing Solutions**

*Ideal Care Helpline: 01482 498610*

## Further information

If you would like information about Ideal Boilers please complete this sheet and fax it to us on 01482 498699 or post it to Caradon Ideal Limited, PO Box 103, National Avenue, Kingston upon Hull, HU5 4JN.

### Installer details

Name

Address

Post Code

Telephone (Please include STD code)

### General information required

- Please send me details of Ideal Training Courses.
- Please arrange for a technical representative to contact me.
- Please arrange for me to join an Ideal factory tour.

### Range guides required

- The Ideal Guide: a specifier's and installer's introduction to the Ideal domestic boiler range.
- The Ideal Householders Guide: to assist the installer when presenting to his/her customers.

### Technical manuals required

- The Ideal Classic wall hung boiler
- The Ideal Classic System wall hung boiler
- The Ideal Classic LX Deluxe wall hung boiler
- The Ideal Mexico floor standing boiler
- The Ideal Minimiser heat-saving boiler
- The Ideal Response combi. boiler
- The Ideal Response SE super efficiency combi boiler
- The Ideal Systemiser SE super efficiency system boiler
- The Ideal Concord high output boiler
- The Ideal Buccaneer oil fired boiler

**Caradon**   
**Plumbing Solutions**

PO Box 103, National Avenue, Kingston upon Hull, HU5 4JN. Telephone: 01482 492251 Fax: 01482 448858.

***Ideal Care Helpline: 01482 498610***

U.I.N. 111 498

