



## **Glow-worm**

Nottingham Road  
Belper  
Derbyshire  
DE56 1JT

Head Office:  
01773 824 639

Literature:  
01773 596 105

After Sales Service:  
01773 596 510

Technical Advice:  
01773 828 300  
(Boiler)

08447 361 143  
(Renewables)

Training:  
01773 596 156

# **Glow•worm**

[www.glow-worm.co.uk](http://www.glow-worm.co.uk)



INVESTOR IN PEOPLE

GWTECV710

# Glow•worm

## Clearly Heat Pumps Technical Guide



[www.glow-worm.co.uk](http://www.glow-worm.co.uk)

# Introduction

At Glow-worm we specialise in the most practical and straightforward renewable energy solutions all supported from beginning to end by Glow-worm's experienced pre and after-sales services, assisting you to make the right choices in this changing world of heating and hot water technologies.

The Glow-worm Clearly Heat Pumps Technical Guide is designed to assist with the selection and installation of our latest range of air to water heat pumps - providing all the technical information you will ever need, in one easy to use booklet.

With over 75 years of experience in providing UK homes with value for money heating and hot water solutions, Glow-worm has built a reputation on providing straightforward and reliable systems you can depend on.

Glow-worm not only provides straightforward renewable systems with easy ordering and totally flexible delivery, we also provide you with expert help and friendly support through design, technical help, extensive training courses, specialist onsite support and a nationwide after sales and spares network.

If you require technical advice, simply call our dedicated renewable technical help line 0844 736 1143 for a fast and straightforward answer.

We hope this brochure gives you all the information you need to help you take the next stage in selecting your new Glow-worm air to water heat pump. Should you wish to discuss any area in more detail or if you need any further information, please contact us to see how we can help.



Introduction	2
Clearly Heat Pumps 7, 12, 14kW Features & Benefits	4 - 5
Clearly Heat Pumps 5kW Features & Benefits	6 - 7
System components	8 - 9
Technical information	10 - 11
System sizing	12 - 13
Siting	13 - 17
Envirosorb <sub>5</sub> schematics and wiring (Clearly Heat Pumps 5kW)	18 - 19
Envirosorb <sub>2</sub> schematics and wiring (Clearly Heat Pumps 7, 12, 14kW)	20 - 21
Envirosorb <sub>2</sub> including DHW (Clearly Heat Pumps 7, 12, 14kW)	22 - 23
Zoning	24
Easy ordering	24 - 25
Technical specifications	26 - 27
Clearly Hybrid	28 - 29
Support & advice	30 - 31

## Contact us

By phone

**07773 824 639**

By email

**[info@glow-worm.co.uk](mailto:info@glow-worm.co.uk)**

By web

**[www.glow-wormheating.co.uk](http://www.glow-wormheating.co.uk)**

# **NEW** Clearly Heat Pumps – 7, 12, 14kW Features & Benefits

At Glow-worm, we specialise in creating the most practical and straightforward air to water heat pump solutions for homes across the UK. Glow-worm's new straightforward air to water heat pump system has been designed for hassle free installation and complete heating comfort.

The new 7, 12 and 14kW models combine high performance inverter compressor technology with straightforward and hassle free installation to form the basis of a brand new Clearly Heat Pumps range.

Utilising next generation technology, Glow-worm's new Clearly Heat Pumps range offers a high performance Central Heating and Domestic Hot Water solution for a wide range of domestic properties delivering excellent green credentials with possible carbon savings of up to 40%\* and an impressive Coefficient of Performance (CoP) of up to 4.06 at A7/W35\*\*

## **Key benefits**

- Straightforward range of air to water heat pump systems for high-performance central heating and domestic hot water
- 7,12 and 14kW output models available
- Range features innovative inverter compressor technology
- MCS-accredited range
- Hydraulic module eliminates the need for glycol in the central heating circuit
- No additional buffer vessels required - creating one compact space-saving system
- Can deliver significant carbon savings and help to achieve level 4 of Code for Sustainable Homes
- Quick and easy installation with no F gas qualifications required
- Ultra-quiet operation
- One complete system: heat pump, hydraulic module and controls in a package that's simple to order
- Can be used in conjunction with the intuitive Climapro<sub>2</sub> RF handheld programmable room thermostat

\* When replacing an older standard efficiency boiler

\*\*Tested to EN 14511

**Envirosorb<sub>2</sub>**  
For use with  
Clearly Heat Pumps  
12, 14kW



**Envirosorb<sub>2</sub>**  
For use with  
Clearly Heat Pumps  
7kW

# **NEW** Clearly Heat Pumps - 5kW Features & Benefits

Clearly Heat Pumps 5kW combines high performance renewable technology with straightforward installation, to provide a highly efficient central heating and domestic hot water solution for smaller, well insulated properties.

Installation and servicing is hassle free with no F gas qualifications needed to install and no need for glycol in the central heating circuit, thanks to advances in its Hydraulic Module system technology. All components are easily accessible within the compact unit and no separate expansion vessels or additional buffer vessels are required, making this one of the most installation friendly heat pumps available on the UK market.

This highly efficient heat pump system provides excellent green credentials and can contribute significantly towards meeting a range of environmental legislative targets. Clearly Heat Pumps 5kW can deliver carbon savings of over 40%\* and can be used to help achieve level 4 of the Code for Sustainable Homes. Clearly Heat Pumps 5kW also has full MCS Accreditation meaning that it is eligible for possible future RHI funding.

\*when replacing an older, standard efficiency boiler

## **Key benefits**

- Highly efficient heating and hot water solution for smaller properties
- One complete system: includes system control unit, wireless outdoor sensor & Climapro<sub>2</sub> RF wireless programmable control
- Compact in size
- Ultra quiet operation
- Quick and straightforward to install & service, with no F Gas qualifications required
- No Glycol needed in the central heating circuit
- Compact, wall-hung hydraulic module including small buffer vessel, expansion vessel, circulating pump, filling valves, PRV and back up heater
- MCS accredited
- Can help to achieve Code for Sustainable Homes level 4
- Comprehensive back up from nationwide after sales service
- Can be used in conjunction with the intuitive Climapro<sub>2</sub> RF handheld programmable room thermostat



**Enviro-sorb 5**  
For use with  
Clearly Heat Pumps  
5kW



# Introducing Glow-worm's complete range of straightforward air to water heat pumps

## System components

### Envirosorb<sub>5</sub> (for Clearly Heat Pumps 5kW) 5kW model available

The slimline air to water heat pump is extremely quiet and very compact. With a COP of 3.73 it produces almost 5kW of heat energy which can be used for central heating and domestic hot water.

The heat pump is also incredibly straightforward to install with no F Gas qualifications required and no glycol needed in the central heating circuit.

#### Dimensions

935mm x 880mm x 345mm

#### Key features

- Slimline and compact monobloc outdoor unit
- High COP efficiency of 3.73\*
- Uses non ozone depleting R410a refrigerant
- No F-gas qualification needed to install
- Extremely quiet – modulating DC fan speed of 180-660 rpm
- All components easily accessible for servicing/replacement

\*Measured at air temperature 7°C and water at 35°C



### Envirosorb<sub>2</sub> (for Clearly Heat Pumps 7, 12 & 14kW) 7, 12, & 14kW models available

The air to water heat pump offers a slimline and attractive outdoor unit solution. The impressive Envirosorb<sub>2</sub> also benefits from advanced inverter compressor technology.

#### Dimensions

7kW Model: 821mm x 908mm x 326mm

12 & 14kW Models: 1363mm x 908mm x 326mm



#### Key features

- 7, 12 and 14kW models feature inverter technology
- No F gas qualifications needed for installation
- Prefilled with R410A non ozone depleting refrigerant
- All components easily accessible for installation/servicing
- Excellent Coefficient of Performance of up to 4.06. \*
- High flow temperature up to 60°C

\*Measured at air temperature 7°C and water at 35°C



### Hydraulic Module SA

The Hydraulic Module contains the circulating pump, which transfers the heat generated by the heat pump into the heating system. It also separates the heat pump circuit from the central heating circuit meaning that you don't need to fill the whole system with glycol anti-freeze. The Hydraulic Module in itself is compact and easy to install, as no separate expansion vessel or additional buffer vessels are required.

#### Dimensions

890mm x 418mm x 370mm

#### Key features

- Single indoor unit
- 6 kW variable immersion heater to ensure maximum end user comfort
- Incorporates two three way valves for easy filling of the glycol circuit

### Climapro<sub>2</sub> RF

Glow-worm's most intuitive and user friendly control; Climapro<sub>2</sub> RF is the main point of interaction with the system for the homeowner. The handheld control enables homeowners to simply and quickly programme their specific heating and hot water requirements in detail, from the comfort of their armchair.

#### Key features

- Wireless, programmable room thermostat for complete time and temperature control
- Large backlit display
- Handheld unit, can be wall mounted or taken around the home
- Provides room and weather compensation when combined with wireless outdoor sensor



### Systempro

The Systempro acts as a central installer interface, where maintenance menus, fault history, system parameters, etc. can all be programmed and accessed.

#### Dimensions

290mm x 264mm x 45mm

#### Key features

- Intelligent wiring centre for the system
- Central installer interface
- No need for end user interaction
- Can be used to control a multi-zone system

### Wireless outdoor sensor

The Glow-worm wireless outdoor sensor intelligently communicates the outside temperature to the rest of the system to provide weather compensated flow temperatures for maximum efficiency. The sensor is small and discreet, and no external wiring is required between the unit and the rest of the system.

#### Key features

- Works on indirect sunlight, which charges the inbuilt PV cells
- No maintenance required
- Simple and quick to install



**Glow-worm cylinder**  
Clearly Heat Pumps is compatible with Glow-worm's range of stainless steel hot water twin coil cylinders.

# Clearly Heat Pumps

## Technical information

### Heat pump efficiencies

COP – The 'Coefficient of Performance' simply put is the relationship between the power consumed by the appliance and the output in heat. For example a 90% efficient gas boiler can produce 0.9kW of heat from every 1kW of gas it uses, giving it a COP of 0.9. However, under the correct conditions, a heat pump can produce up to 4kW of heat from every 1kW of electricity it uses (giving it a COP of 4) Glow-worm's Clearly Heat Pumps range have COPs up to 4.06.

### The compressor

The compressor is the heart of the heat pump which needs to be protected. Some heat pumps such as the Glow-worm EnviroSorb<sub>2</sub> (for Clearly Heat Pumps 7, 12, 14kW) have an inverter compressor which means that the heat pump is able to modulate the compressor to suit the energy needs of the home which helps to protect it coming on, and going off frequently. An inverter compressor is essential on larger output heat pumps to maximise the life of the appliance and capitalise on the efficiency of the system.



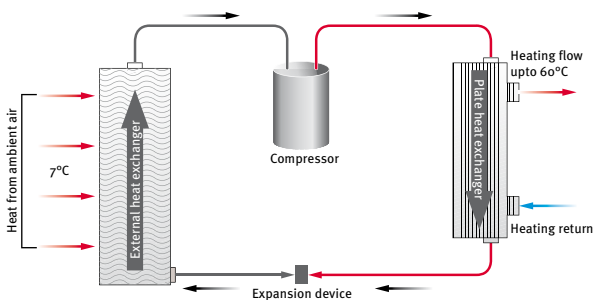

## Refrigeration cycle

Using exactly the same principles as a fridge, the heat pump employs the characteristics of a refrigerant. A fan draws air across a large heat exchanger (or evaporator coil). As the refrigerant has a very low boiling point, even in the depths of winter, this refrigerant is boiling.

The refrigerant passes into the compressor, where it is compressed (think of the effect of a bicycle pump) to take it up to a temperature we can use to heat the home.

The now hot gas passes into a plate heat exchanger, where it gives up its heat to the heating system flow, whilst turning into a liquid. With the hot system water now on its way round the heating system, the refrigerant liquid finally passes through an expansion valve. The expansion valve acts like an aerosol, turning it back into a low temperature gas, to begin the whole process all over again.

# Technical information

## System sizing

Naturally, a unit that uses air as its source for heat, will perform better as the temperature of that air increases. The industry standard for quoting the output of heat pumps is Air 7/ Water 35. So, a 14kW heat pump will deliver 14kW at an air temperature of 7°C when generating a flow temperature of 35°C. Below are the outputs at various other temperatures. The lower the flow temperature, and the higher the ambient temperature, the more efficient they become: the system should therefore be designed for as low flow temperature as possible.

### Available Power - The Glow-worm range

Outdoor temp	Units	5kW	7kW	12kW	14kW
<b>35° Flow</b>					
-5	kW	3.1	4.55	7.40	8.31
	COP	2.45	2.71	2.75	2.62
2	kW	4	5.41	8.72	10.2
	COP	3.1	2.99	3.11	3.2
7	kW	4.8	7.2	11.82	14.5
	COP	3.8	3.9	3.9	4.06
<b>45° Flow</b>					
-5	kW	2.6	4.45	6.96	7.9
	COP	1.8	2.28	2.24	2.1
2	kW	3.9	5.38	8.45	10.2
	COP	2.6	2.55	2.61	2.6
7	kW	4.5	7.4	11.38	14
	COP	3.1	3.16	3.03	3.21
<b>55° Flow</b>					
-5	kW	2.02	4.24	7.06	7.6
	COP	1.38	2.02	1.92	1.8
2	kW	3.7	5.14	8.47	10.2
	COP	2.15	2.34	2.2	2.6
7	kW	4.35	6.71	11.04	13.9
	COP	2.5	2.68	2.5	2.82

### Functioning limits of the 7-14kW heat pump during heating

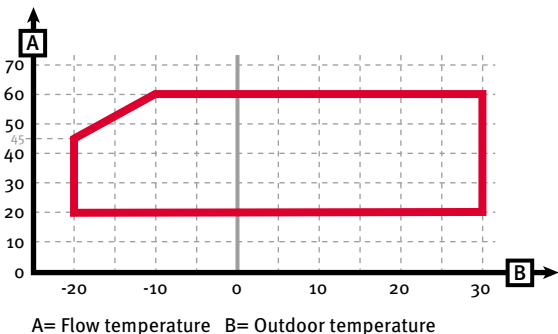

# Technical information

For a design with a 45 degree flow temperature, such as underfloor heating, or correctly sized radiators, the table below shows the maximum size of a property each output is suitable for, based on build year. Please note this does not take into account DHW.

These maximum sizes will ensure 100% coverage down to -5°C.

	5kW	7kW	12kW	14kW
New build (to 2010 regs)	up to 65m <sup>2</sup>	up to 100m <sup>2</sup>	up to 185m <sup>2</sup>	up to 200m <sup>2</sup>
2006 - 2010	up to 50m <sup>2</sup>	up to 90m <sup>2</sup>	up to 135m <sup>2</sup>	up to 155m <sup>2</sup>
1995 - 2005		up to 55m <sup>2</sup>	up to 85m <sup>2</sup>	up to 100m <sup>2</sup>
1975 - 1995			up to 70m <sup>2</sup>	up to 80m <sup>2</sup>

## Pipe Sizing

Consideration needs to be given to the lower flow temperatures that come from heat pumps, and also the smaller  $\Delta t$  required (5°C):

Typically systems from 4-10kW should be in 28mm. 10kW - 14kW should be in 35mm (Some 14kW systems may require 42mm)

# Technical information Siting

## AWHP unit dimensions

All measurements in mm.

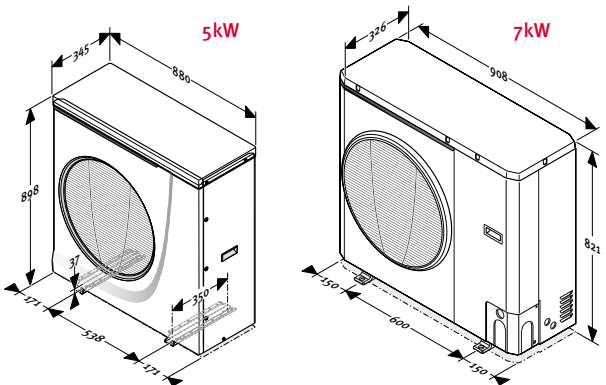

# Technical information

## Siting

### AWHP unit dimensions

All measurements in mm.

12-14kW

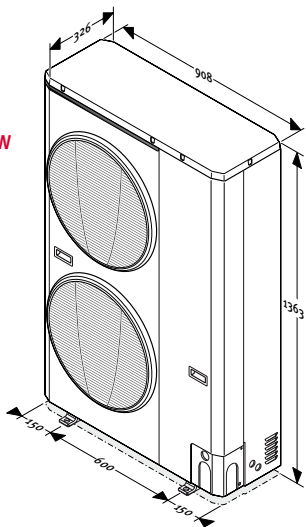

### Hydraulic Module

The Hydraulic Module must be placed indoors.

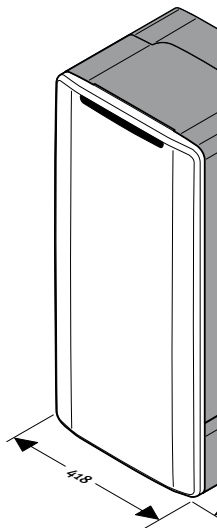
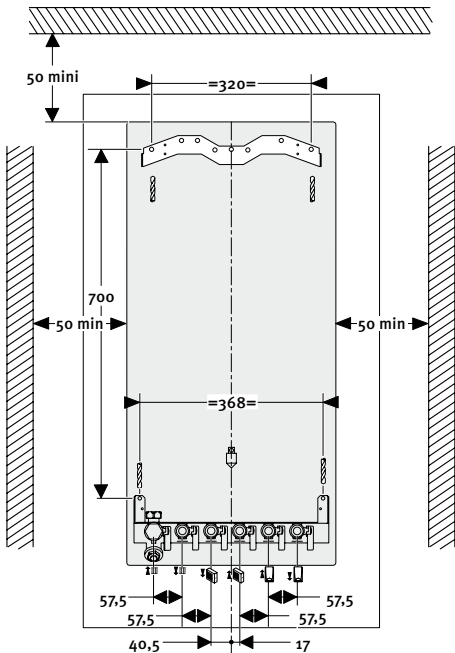

All measurements in mm.

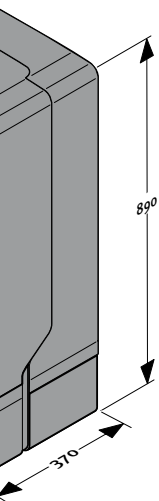
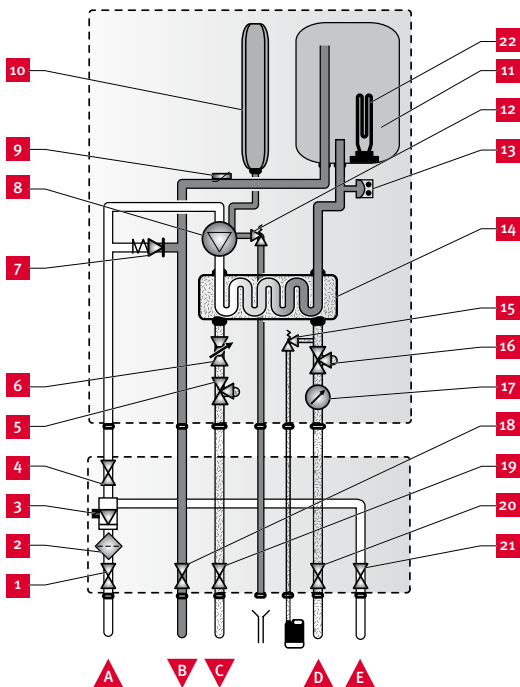

- 1 Heating circuit return shutoff valve
  - 2 Heating filter
  - 3 Disconnecter
  - 4 Filler tap
  - 5 3-way valve with shut-off valve for glycol refilling
  - 6 Balancing valve
  - 7 By-pass
  - 8 Pump
  - 9 Heating outlet temperature sensor
  - 10 Expansion tank
  - 11 Tank
  - 12 Heating circuit safety valve
  - 13 Pressure sensor
  - 14 Plate heat exchanger
  - 15 Heat pump circuit safety valve
  - 16 3-way valve with shut-off valve for glycol refilling
  - 17 Pressure gauge
  - 18 Heating circuit flow shutoff valve
  - 19 Heat pump return circuit shutoff valve
  - 20 Heat pump flow circuit shutoff valve
  - 21 Cold water inlet shutoff tap
  - 22 Electric back-up heater
- 
- A Heating circuit return
  - B Heating circuit flow
  - C Heat pump circuit return
  - D Heat pump circuit flow
  - E Cold water inlet



## Minimum Clearances

Although these are minimum clearances, please note that the air expelled to the front of heat pumps is extremely cold which needs to be taken into consideration. As cold air sinks, placing an air to water heat pump in a small, enclosed garden will chill the air available to the unit, and impede its operation and efficiency. Raising the units slightly off the ground by using wall brackets or a stand will improve the efficiency.



The unit should ideally be:

- South facing
- Sited in a wide open space



The unit should NOT be:

- Placed inside an enclosed space (e.g. a garage)
- Placed next to a fence

5kW

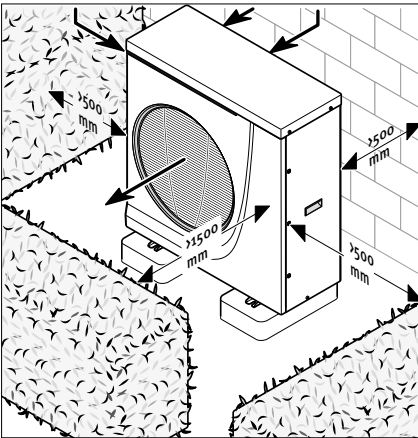

7-14kW

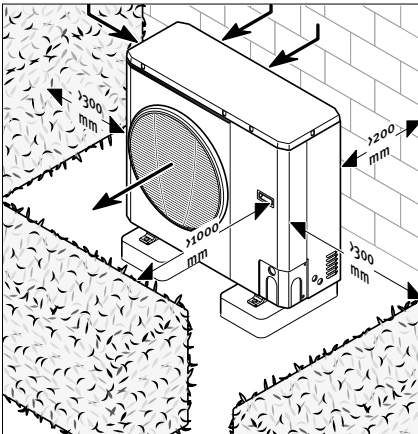

**Please note:**

- Air source heat pumps do not fall within 'permitted developments', therefore planning permission should always be sought
- Care should be taken to ensure condensate can drain away freely
- To avoid noise transmission from the unit into the home, flexible hoses should be used immediately off the heat pump
- Connections to the rear of the heat pumps are 1" BSP male threads
- All external pipe work must be insulated to prevent heat loss
- To maximise efficiency, distance from heat pump to the hydraulic module should be as short as possible.
- The recommended Glycol solution of 30% will protect the heat pump down to -15°C
- The 230V power cable to the heat pump should be 3 x 2.5mm<sup>2</sup> while eBus and control cables should be 0.75mm<sup>2</sup>.
- Heat pump should be raised sufficiently for condensate to drain away without risk of freezing.

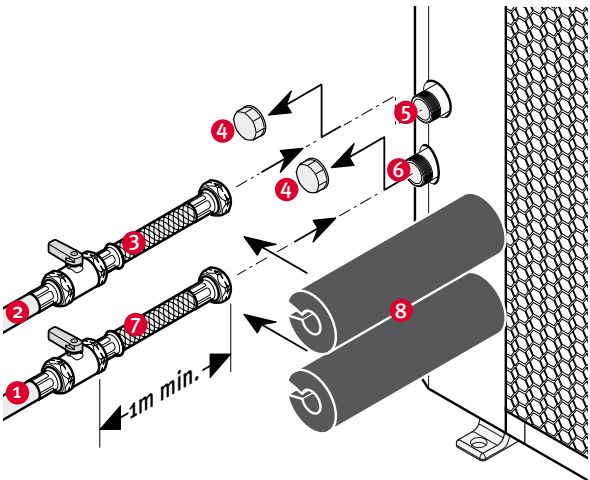

Flexible hoses to be used to avoid noise transmission.

**Hydraulic connections :**

- 1 Heat pump flow circuit 1/4 turn shut-off valve in the direction of the building (not included)
- 2 Return circuit 1/4 turn shut-off valve in the direction of the heat pump (not included)
- 3 Return circuit hose in the direction of the heat pump (not supplied)
- 4 Cap
- 5 Return connection (Ø1 «) to the heat pump
- 6 Flow heat pump connection (Ø1 «) to the building
- 7 Flow heat pump circuit hose in the direction of the building (not supplied)
- 8 Insulation (not supplied)

# Envirosorb 5 schematics and wiring (for Clearly Heat Pumps 5kW)

## Key points –

Connection to the Envirosorb 5kW heat pump - Select Systempro scheme 4

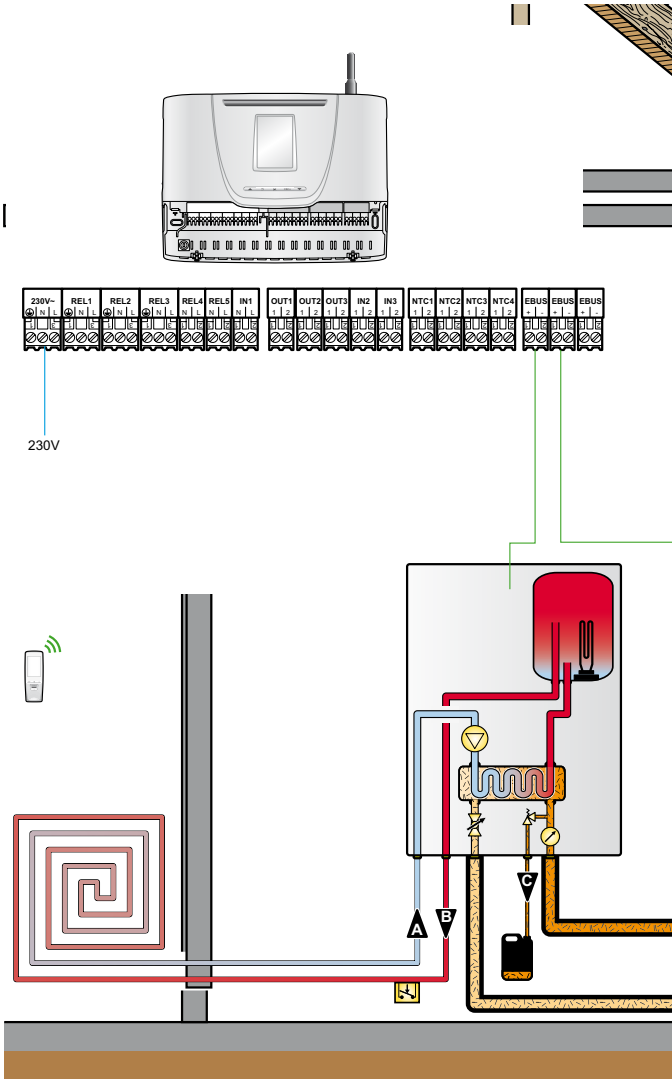

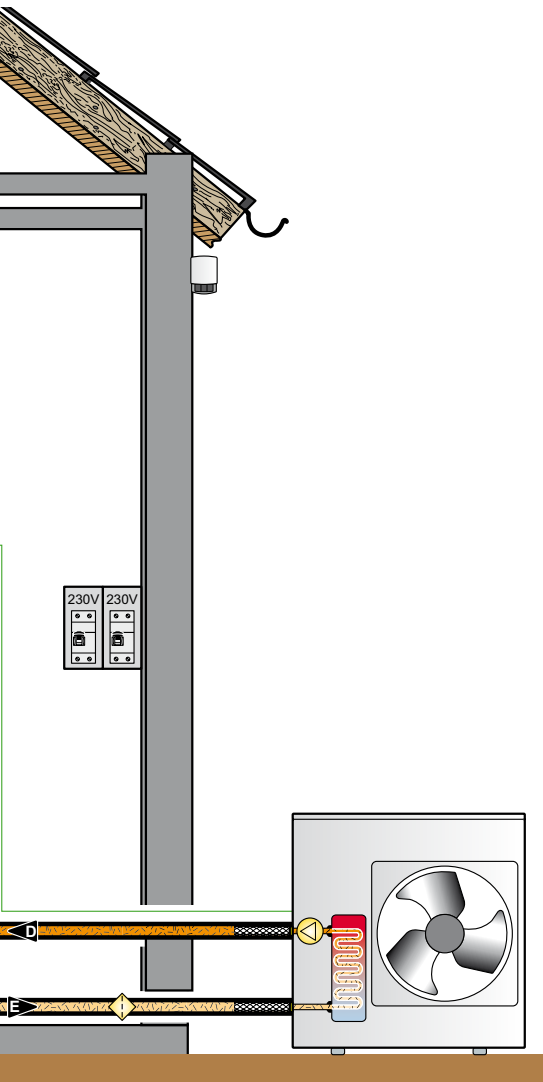

# Envirosorb<sub>2</sub> schematics and wiring (for Clearly Heat Pumps 7-14kW)

## Connection to the Envirosorb<sub>2</sub> 7-14kW range Select Systempro scheme 7

- 1 Heat pump controlled by On/Off contact
  - 2 Heat pump circuit filter (not supplied)
  - 3 Hydraulic module
  - 4 Heat pump electrical supply and protection (This must have its own single isolation)
  - 5 Hydraulic module electrical supply and protection
  - 6 Heat pump control box
  - 7 Wireless outdoor sensor with solar panel
  - 8 Systempro control unit
  - 9 Climapro<sub>2</sub> RF programmable wireless room thermostat
  - 10 Heating circuit
  - 11 Overheating Safety (if underfloor heating)
  - 12 Glycol PRV discharge
- 
- A Heating circuit return
  - B Heating circuit flow
  - C Heat pump circuit safety valve discharge
  - D Heat pump circuit flow
  - E Heat pump circuit return

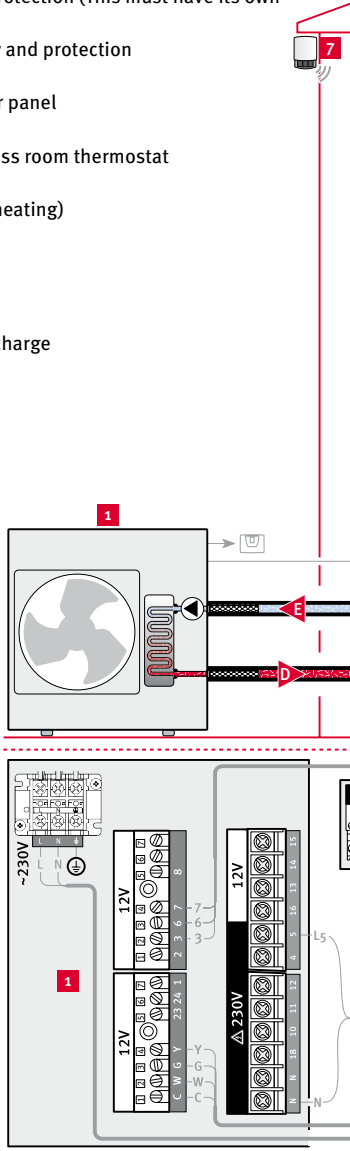





Note: The 3 port valve must be a 3 port diverter, and not a mid-position valve. It must be installed, so that it powers open the DHW circuit, and spring returns to close the DHW circuit. (Suitable valve would be a Honeywell 4044c reversed or similar).

A suitable 16A relay will be needed for the immersion heater in the cylinder.

The cylinder should have 2 sensor pockets, top and bottom, as control is done with 2 sensors. The top one manages the immersion heater. The bottom one controls the heat pump. Systempro intelligently uses both to achieve maximum DHW performance, minimum re-heat time, and optimum system performance.

Glow-worm's Flurocyl twin coil cylinder range is suitable up to 12kW. For the 14kW heat pump, a larger surface area coil is necessary (ideally 3m<sup>2</sup> of surface area).

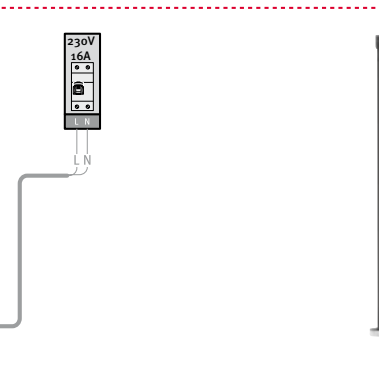
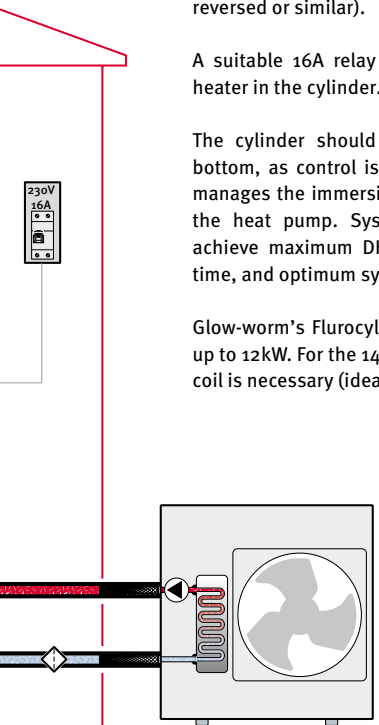



# Zoning

- Systempro can manage up to 3 zones plus DHW
- An additional Climapro<sub>2</sub> will be needed for each additional zone (0020085220)

## Clearly Heat Pumps easy ordering

As part of Glow-worm's commitment to making things simple, the Clearly Heat Pumps range is available through a straightforward easy to order pack solution, containing all Clearly Heat Pump system components.

### Clearly Heat Pump packs - Straightforward ordering

Pack contents	Clearly Heat Pumps 5kW Pack
Article No.	0020114863
Envirosorb 5 5kW	✓
Envirosorb <sub>2</sub> 7kW	✗
Envirosorb <sub>2</sub> 12kW	✗
Envirosorb <sub>2</sub> 14kW	✗
Hydraulic module SA	✓
Systempro controller	✓
Climapro <sub>2</sub> RF	✓
Wireless Outdoor Sensor	✓



Clearly Heat Pumps 7kW Pack	Clearly Heat Pumps 12kW Pack	Clearly Heat Pumps 14kW Pack
0010012956	0010012957	0010012958
x	x	x
✓	x	x
x	✓	x
x	x	✓
✓	✓	✓
✓	✓	✓
✓	✓	✓
✓	✓	✓

# Clearly Heat Pumps technical specifications

## Clearly Heat Pump specifications

Description
Min. operating outside temperature (in heating)
Max. operating outside temperature (in heating)
<b>Specifications, with underfloor heating</b>
(flow : 35°C, return : 30°C, outside dry temperature (wet) : 7 (6)°C)
Heating output
Power input
Rated electrical current
COP* A7(6) W35-30
<b>Specification with radiators</b>
(flow : 45°C, return : 40°C, outside dry temperature (wet) 7 (6)°C)
Heating output
Power input
Rated electrical current
COP* A7(6) W45-40
<b>Refrigerant circuit</b>
Type of refrigerant
Quantity of refrigerant
Type of compressor
Type of oil
Type of regulator
Fan speed
Maximum operating pressure (PS)
<b>Heat pump circuit</b>
Max. supply pressure
Nominal static pressure
Nominal water flow rate in heating mode
Minimum water flow rate
Minimum flow temperature setting (in heating)
Maximum flow temperature setting (in heating)
Heat pump water volume
<b>Electrical</b>
Supply voltage/frequency
Fuse
Maximum absorbed power (P max)
Maximum absorbed current (I max)
Index of electrical protection
Electrical classification
<b>Dimensions</b>
Height
Width
Depth
Ø Water circuit connections
Nett total weight
Sound power level : overall exterior noise (according to EN 12102 and EN ISO 9614-1)

Units	5	7	12	14
°C	-7	-20	-20	-20
°C	35	30	30	30
kW	4.7	7.2	11.9	14.5
kW	1.26	1.82	3.01	3.6
A	5.48	8	13	15.6
	3.73	3.96	3.94	4.06
kW	4.41	7.4	12.9	14
kW	1.46	2.32	4.2	4.4
A	6.34	10	18.5	19
	3.02	3.18	3.03	3.21
	R410a	R410a	R410a	R410a
kg	1.8	1.81	2.485	3.385
Rotary				
Polyolester				
Electronic				
rpm	180-660	200-680	250-750	200-820
bar	43.2	45	45	45
Pa	43.2*10 <sup>5</sup>	45*10 <sup>5</sup>	45*10 <sup>5</sup>	45*10 <sup>5</sup>
bar	3	3	3	3
Pa	3*10 <sup>5</sup>	3*10 <sup>5</sup>	3*10 <sup>5</sup>	3*10 <sup>5</sup>
bar	1	0.4	0.45	0.3
Pa	1*10 <sup>5</sup>	4*10 <sup>3</sup>	4*10 <sup>3</sup>	4*10 <sup>3</sup>
l/h	800	500	500	500
l/h	500	420	420	420
°C	25	20	20	20
°C	55	60	60	60
l	1	1.2	2.3	2.3
V/Hz	1/N/PE 230V 50Hz			
A	15 type B	15 type B	25 type D	25 type D
kW	1.45	2.7	5.1	5.1
A	6.7	14	23	20
	IPX4	IPX4	IPX4	IPX4
	1	1	1	1
mm	935	821	1363	1363
mm	880	908	908	908
mm	345	326	326	326
"	1	1	1	1
kg	82.5	71	105	130
dBA	62.6	64	67	68

**Notes:**

\* Coefficient of Performance (according to EN 14511)

# Clearly Hybrid system

The Enviroorb 5 heat pump is also available as part of Glow-worm's Clearly Hybrid system, which is the UK's first hybrid renewable domestic heating and hot water system using advanced controls to select the most cost effective method of heating at any time.

The Clearly Hybrid system combines the use of a High Efficiency Glow-worm boiler, such as the Ultracom<sub>2</sub> with the Enviroorb 5 air to water heat pump. The revolutionary heating system automatically selects when to use low carbon renewable energy from the heat pump or traditional energy from the High Efficiency boiler, to always deliver cost effective heating and hot water to your customers.

The Clearly Hybrid system provides a perfect solution for consumers and organisations that are looking to use new, yet proven, technologies to deliver cost effective heating and reduce their carbon footprint.

## Key benefits of Clearly Hybrid

- Automatically chooses the most efficient fuel source - cost effective operation and lower carbon footprint
- One complete package: heat pump, hydraulic module and control - easy to install and commission
- Use with any new Glow-worm High Efficiency boiler: combi, system and open vent models
- Includes Glow-worm's high performance Enviroorb 5 air source heat pump
- Full system with clear and simple operating controls
- Can achieve over 40% carbon savings\*

\*When replacing an older, standard efficiency boiler

Enviroorb 5



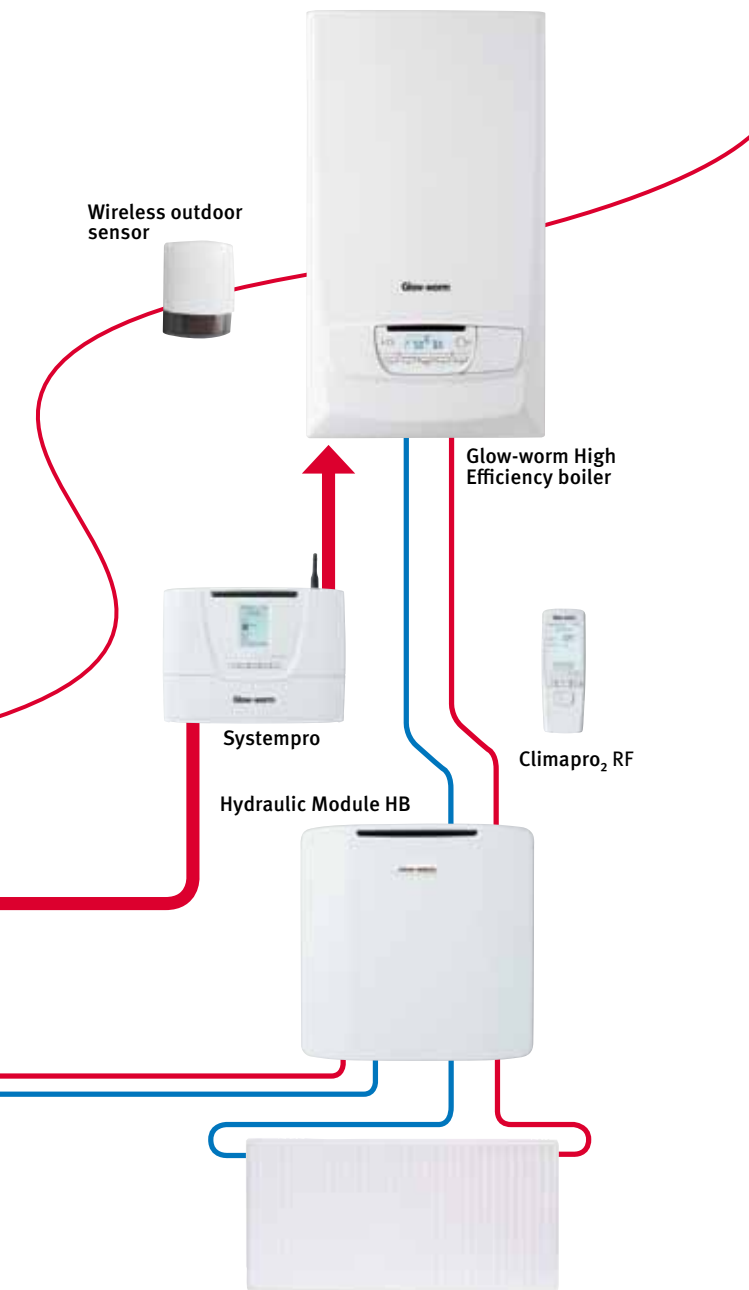

# Expert support & advice from start to finish

## System design

Good designs are incredibly important if you are going to get the highest level of efficiency and pay back from a Clearly Heat Pump system. Our award winning, expert design service is completely tailored to suit your individual site requirements. Using the latest state of the art CAD technology we provide high quality designs supported by full indemnity cover.

Our expert systems technologies team can also provide planning and on site support for the most unique and challenging of renewables projects.

## Straightforward delivery

Glow-worm will deliver your Clearly Heat Pump system anywhere you want, be it direct to site or to your local trade counter where you placed your order. Our standard delivery service is 3 – 5 days from receipt of order, but you can choose a next day or timed delivery if you need things quicker.\*

To ensure the site is ready to accept the delivery, we will call when we are 1 hour away from the delivery destination and will arrive with all the correct lifting equipment to ensure that the product is safely transferred to site – life couldn't be easier.

\*Subject to an additional charge

## Technical help

If you are planning or even in the middle of an installation and have a technical question you need answering, simply call our technical help line on 08447 361 143 for a straightforward answer.

## Full local support

Our nationwide sales team provide installers and specifiers with support and partnership from beginning to end.

## Nationwide after sales service

We are committed to supporting you with technical help and after sales service online, over the telephone and through our network of dedicated fully trained renewable engineers on the road.

## Spares

If in the unlikely event a problem occurs and a genuine spare part is needed, then you can rest assured that Glow-worm's market leading spare parts division will have the item you require. Thanks to our commitment towards maintaining functional spare parts, availability is for up to 15 years after the range production ends.

## Training

Glow-worm offers a wide range of training courses to suit your every need, covering its full range of High Efficiency boilers, and renewable products.

Our renewable technologies courses include Clearly Solar, Clearly Heat Pumps (including Clearly Hybrid) and Clearly Heat Recovery product training as well as accredited courses such as solar and heat pump BPEC courses, and G3. Glow-worm also offer an MCS quality management course at our Centres of Excellence across the UK.

## Online information

If you require standard technical advice information such as installation manuals and don't want to spend time on the telephone, visit our website at [www.glow-worm.co.uk](http://www.glow-worm.co.uk) where you will find comprehensive technical information, solutions to common installation, system problems and advice on energy saving.

