

The **New** Remeha Quinta Pro Cascade & Skid Mounted Systems



High efficiency wall hung or free standing condensing boilers with ultra low NO_x emission

QUINTA PRO CASCADE & SKID MOUNTED SYSTEM OUTPUTS (2-6 BOILERS)

QP30: 8.0 - 31.4 kW

QP45: 8.0 - 43.0 kW

QP65: 12.0 - 65.0 kW

QP90: 14.1 - 89.5 kW

QP115: 16.6 - 114.0 kW

SEDBUK RATED (QP30, QP45, QP65)



Introduction

This technical information contains useful and important information for proper dimensioning of a cascade system with wall-mounted boilers.

It describes the correct use of the complete Remeha cascade systems with the modulating wall-mounted boilers Quinta Pro 30/45/65/90/115.

Please contact us if you have any questions or for further information about cascade configurations.

Contents

	page
Introduction	2
Cascade description	2-4
Cascade wall mounted linear system	5
Cascade free standing linear system	6
Cascade free standing back-to-back system	7
Gas connection for air & exhaust pipes	8-9
Skid Mounted description	10
Skid linear configuration - 2 boilers	12
Skid linear configuration- 3 boilers	13
Skid back-to-back configuration - 4 boilers	14
Skid back-to-back configuration - 6 boilers	15
Flue gas table for combined flue discharge	16
Flue linear configuration	17
Flue dilution system	18
Notes	19

General description of Cascade systems

The optimum number of boilers in a Cascade

In many situations it is advantageous to spread the total required heat output over several boilers. This can be made possible by means of a "cascade system". In a cascade configuration, heating boilers are connected hydraulically. If the heat demand increases or decreases, boilers are switched on or off respectively. If using a Remeha multiple boiler controller or a quality building management system. It is then important to determine the ideal number of boilers for the cascade.

The following factors need to be taken into account when deciding on the number of boilers:

- **Investment;** When boilers are split up, the investment costs (boiler cost including installation, fittings, pipe work, pumps and control equipment) can work out lower or higher. However, this depends to a large extent on the situation.
- **Reliability;** Reliability increases with the number of boilers. Research has shown that reliability is already optimum for systems with four boilers in a cascade.
- **Efficiency;** There is no appreciable difference in terms of efficiency between several small or one or two larger boilers.
- **Maintenance and faults;** There is a greater overall risk of faults in a system with several boilers. A larger group of engineers can service and maintain smaller boilers.
- **Configuration;** The lightweight and compact design means that you have more flexibility when siting the boilers. Very little floor space is required and there is minimum load on the floor.
- **Adjustment;** When using several boilers and modulating control, the heat output offered is virtually equal to the heat output requested.

A number of the points mentioned are dependent on the situation and so consideration as to which solution is the best will need to be given on a project-by-project basis.

The cascade kits are not supplied with the boilers they must be ordered separately.

Compact Cascade configurations

The boilers Quinta Pro 30/45/65/90/115 are particularly suitable for use in a cascade configuration. Their width of only 50 cm means that a high heat output level can be installed on a small wall. This big difference becomes apparent when comparing a Remeha cascade system with cascade systems using boilers from other manufacturers.

For example, using 6 times a Quinta Pro 115, only approx. 3.8 m (including low loss header) wall width is required for 642 (80/60°C) kW. The boilers therefore allow an exceptionally compact cascade configuration.

Cascade systems

For installing 2 to 6 boilers, our product range includes systems that are very comprehensive and easy to install. The hydraulic and gas system can be put together entirely without welding, using screw connections, compression connections and flanges. The individual components of the cascade systems are available for independent cascade installation.

Hydraulic isolation: low loss header

Practical experience has shown that it is beneficial to create hydraulic isolation between the boiler circuit and the system circuit using a low loss header. This means that a widely varying volume flow on the system side hardly influences the volume flow on the boiler side at all. This also applies in reverse: a widely varying volume flow on the boiler side hardly influences the volume flow on the system side at all. Controlling several different groups hydraulically is therefore significantly easier as they do not, or barely, influence each other. This creates better overall operating conditions for the system.

Output control

Use the iSense Pro for up to 6 boilers or the iSense in combination with the Celcia MC4 for a maximum of 4 boilers.

Advantages at a glance

Quinta Pro boiler

- High efficiency: 110% NCV at 40/30°C (99% GCV)
- Boiler control:
 - a) Modulating (18-100%)
 - b) On/off
- Premix burner for clean combustion
- Low NO_x < 39mg/kWh
- Quiet operation < 52 dBA
- LED illuminated air box
- Digital display
- Data file for storing information
- Remote signalling options
- Cast aluminium heat exchanger
- Easy maintenance
- Built-in calorifier control
- Options for modular control and/or weather compensator
- Control 0-10V signal or volt free
- PC connection
- Advanced boiler control, for reliable heat delivery
- Conventional or "room-sealed" operation
- Cascade packages for up to 6 boilers
- Quick and easy installation
- Space saving
- For use with natural gas and L.P.G. (Some models require a conversion kit)
- Suitable for pressurised flue systems

Remeha Cascade systems

In order to make it as simple as possible to create a cascade configuration, our product range has included complete cascade systems for years. The compact design of the boilers, combined with the smart gas and water connection technology of the cascade system, makes it possible to install a high heat output in a small area. For example, using six Quinta Pro 115 boilers, only 3.8 m approx. (including low loss header) wall width is required for 642 kW (80/60°C). The cascade systems can be divided into 3 main groups:

- 2 to 6 boilers in a linear configuration, wall mounted.
- 2 to 6 boilers in a linear configuration, mounted on a free-standing frame.
- 3 to 6 boilers in a back-to-back configuration, mounted on a freestanding frame.

Please contact us for different configurations (specials). We also provide in-depth advice on the choice of flue gas discharge material and control engineering, including for non-standard configurations.

Structure of cascade systems

The return, flow, and gas connections of the individual boilers are connected using the fittings supplied by means of horizontal connections to main pipes for return, flow and gas. These pipes are welded onto a frame that rests on the floor and is fixed to the wall or to a free-standing frame.

The low loss header supplied has flange connections, which can be fitted to the left or right of the cascade main pipe as required. The blind flanges supplied are then fitted on the other side. The gas main pipe has a flange to which the optional gas filter can also be connected on the left or right as required. The blind flange supplied is then fitted on the other side. When a gas filter is used, a pressure loss of 3 mbar over the gas filter must be taken into account.

The minimum inlet working gas pressure after the gas filter is 17 mbar. A common PVC condensed water discharge pipe (not supplied) can be installed in the frame. For this purpose, holes have been made in the frame into which this pipe can be fitted (to the left or right as required) sloping downwards.

Any combination of boilers is possible. See the table for the corresponding heat outputs.

Useful output (kW)	50/30°C	80/60°C
Quinta Pro 30	31.4	29.3
Quinta Pro 45	43.0	40.0
Quinta Pro 65	65.0	61.0
Quinta Pro 90	89.5	84.2
Quinta Pro 115	114.0	107.0

Installation drawings for Cascade systems

The cascade systems can be divided into 3 main groups:

- 2 to 6 boilers in a linear configuration, wall mounted.
- 2 to 6 boilers in a linear configuration, mounted on a free-standing frame.
- 3 to 6 boilers in a back-to-back configuration, mounted on a freestanding frame.

The boiler side of the cascade systems is sized to 20ΔT.

The low loss header is based on 20 / 11ΔT.

Wall-mounted linear configuration (LW) - 2 to 6 boilers

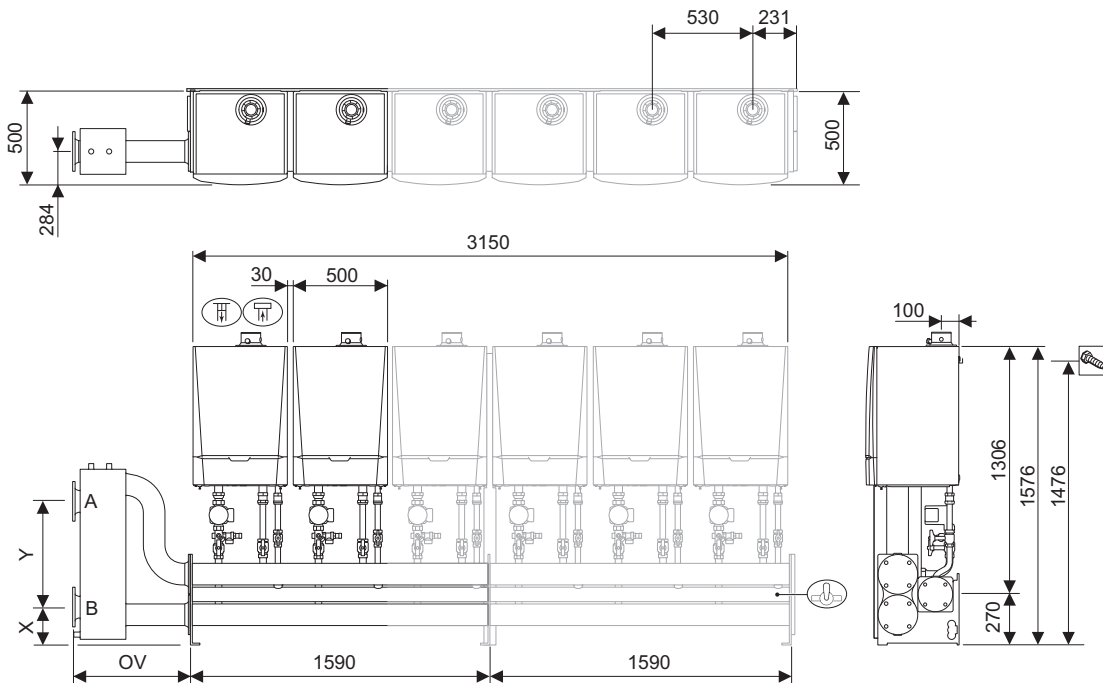





- A System flow; connection Dn 100 or 125/DIN 2631 (8 holes)
- B System return; connection Dn 100 or 125/DIN 2631 (8 holes)
- Gas supply connection Dn 50 or 65/DIN 2633 (4 holes)
- Air inlet / Flue gas discharge concentric connection
- Quinta Pro 30/45 = 80 / 125 mm, Quinta Pro 65/90/115 = 100 / 150 mm
- Suspension points
- OV Low loss header (Dn65 = 633 mm; Dn100 = 643mm)
- X Distance to system return connection = 200 mm
- Y Distance to system flow connection = 560 mm

Dimensions (mm)

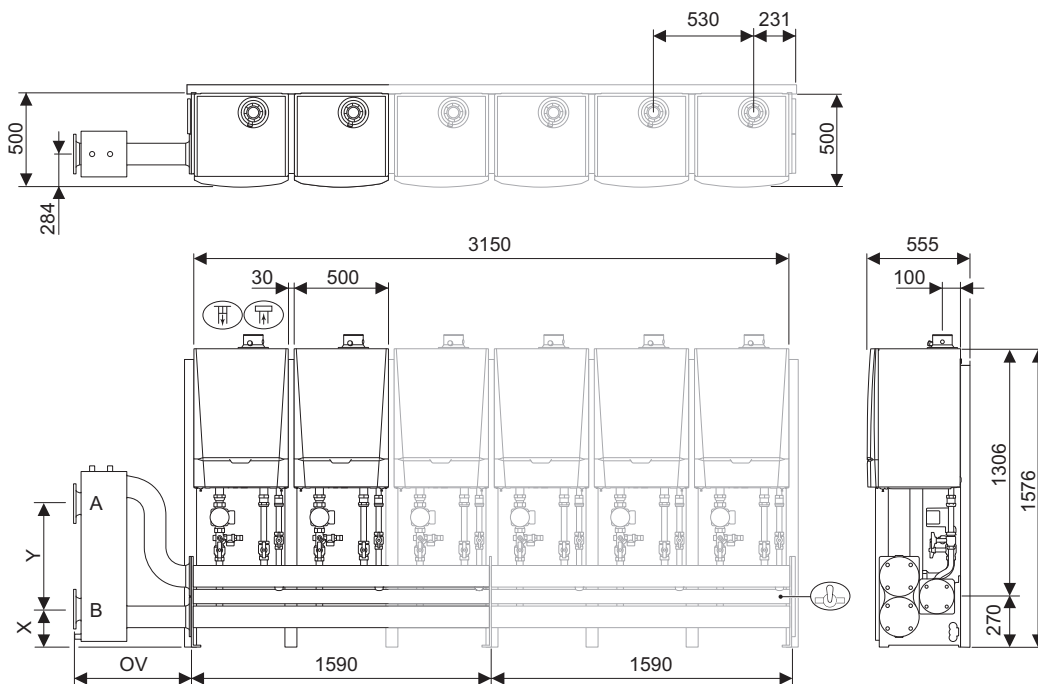
No. of boilers	2	3	4	5	6
Width (mm)	1030	1560	2090	2620	3150

Free-standing linear configuration (LV) - 2 to 6 boilers







- A System flow; connection Dn 100 or 125/DIN 2631 (8 holes)
- B System return; connection Dn 100 or 125/DIN 2631 (8 holes)
-  Gas supply connection Dn 50 or 65/DIN 2633 (4 holes)
-  Air inlet / Flue gas discharge concentric connection
-  Quinta Pro 30/45 = 80 / 125 mm, Quinta Pro 65/90/115 = 100 / 150 mm
-  Suspension points
- OV Low loss header (Dn65 = 633 mm; Dn100 = 643 mm)
- X Distance to system return connection = 200 mm
- Y Distance to system flow connection = 560 mm

Dimensions (mm)

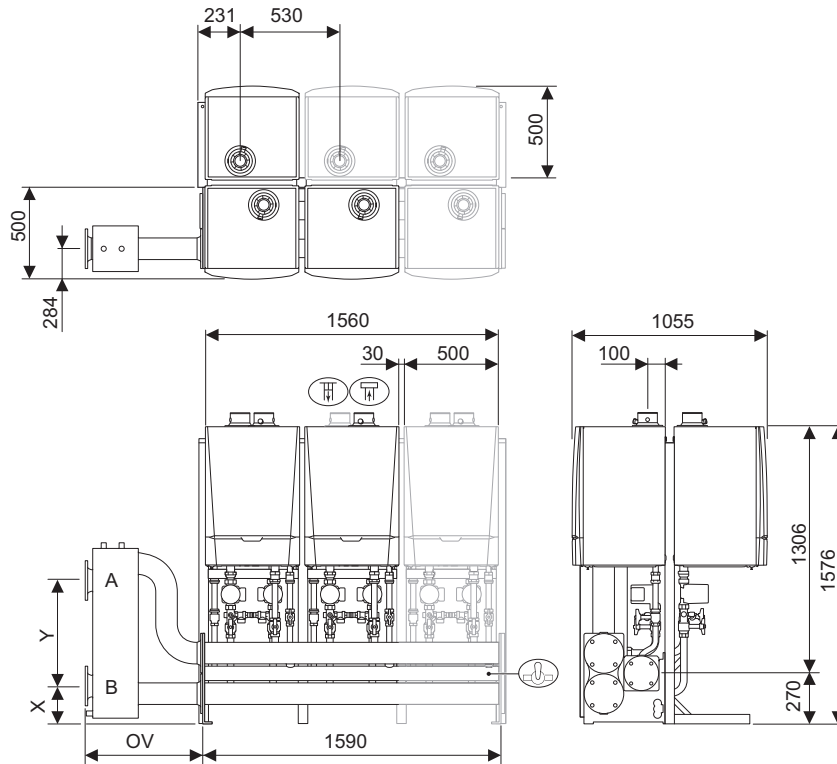
No. of boilers	2	3	4	5	6
Width (mm)	1030	1560	2090	2620	3150

Back-to-back configuration (RG) - 3 to 6 boilers



- A System flow; connection Dn 100 or 125/DIN 2631 (8 holes)
- B System return; connection Dn 100 or 125/DIN 2631 (8 holes)
-  Gas supply connection Dn 50 or 65/DIN 2633 (4 holes)
-  Air inlet / Flue gas discharge concentric connection
-  Quinta Pro 30/45 = 80 / 125 mm, Quinta Pro 65/90/115 = 100 / 150 mm
-  Suspension points
- OV Low loss header (Dn65 = 633 mm; Dn100 = 643 mm)
- X Distance to system return connection = 200 mm
- Y Distance to system flow connection = 560 mm

Dimensions (mm)

No. of boilers	2	3	4	5	6
Width (mm)	1030	1560	2090	2620	3150

Gas Connection

General

The boilers are suitable for use with natural gas and propane category II_{2H3P}. Connect the boilers to the gas mains in accordance with the applicable regulations. For the Quinta Pro boilers, the gas connections are at the bottom of the boiler and are 3/4" male thread. There must be a main gas cock close to the boilers. A gas filter for the gas supply pipe is available as an accessory.

Gas Pressures

The required inlet working pressure per boiler is 17 to 30 mbar. The correct burner pressure setting for natural gas was set at the factory and, in principle, does not need re-adjusting. For propane operation, see the installation service manual for the boilers concerned. The usual inlet pressure for commercial propane (37-50 mbar) can be used.

Connections for the air and exhaust pipes

General

The boilers can be used in room-ventilated or room-sealed operation. The room-open version extracts the necessary combustion air from its environment. In this case via an air supply opening at the top of the boilers. By installing an air supply pipe on the air supply opening, you obtain a room-sealed system.

Individual flue gas discharge

If there is insufficient height for a joint flue gas discharge and/or air supply, individual roof feed-throughs must be installed at the same height on flat or sloping roofs. This avoids flue gases from one boiler being taken in by another boiler. From an aesthetic point of view, the individual roof feed-throughs can be placed within a single feed-through construction. Recirculation problems may arise where discharge takes place into recessed and in the vicinity or rising walls.

If in doubt, please contact us.

Joint flue gas discharge

If there is sufficient height, a collector system can be used (not supplied by us). In the design of the collector system, a distinction is made between a series or parallel configuration. This document only covers the series configuration.

In series configuration, individual boilers are connected directly to a horizontal collector, which then continues on to the vertical section. An advantage of this configuration is that only one (room-ventilated operation) or two (room-sealed operation) collector pipes run immediately above the boilers. It is also possible to link several boilers under overpressure on the flue gas side: This results in smaller diameters of the flue gas discharge pipe. For this purpose, the Quinta Pro boilers have a flue gas non-return valve as standard. This creates a considerable saving on the cost of a combined flue-gas-discharge system with several boilers switched in a cascade. The boiler's parameter settings will need to be changed.

Consult our Technical department about this.

Material requirements

When combining different metals, these must be galvanically isolated. Galvanic isolation (rubber inlay) is also required when using brackets made from a different metal. Fit the flue gas discharge pipe so that it has airtight and watertight joints and connections.

Flue gas discharge material

Because the flue gases condense, the flue gas discharge must not be connected to a brick duct. In situations of this kind, always use a lining tube.

Depending on the design, the following materials may be used:

Material		
A rigid wall ⁽¹⁾	Thick aluminium wall	Approval according to EN-1856-1
	Stainless steel	Approval according to EN-1856-1
	Synthetic material T120	Approval according to Gastec QA or KOMO
Flexible ⁽¹⁾	Stainless steel	Approval according to EN-1856-1
	Synthetic material T120	Approval according to Gastec QA or KOMO

(1) The sealing must conform with pressure class 1

External components must always be insulated.

Air inlet equipment

Depending on the design, the following materials may be used:

Material	
A rigid wall	Aluminium/Stainless Steel/Synthetic material
Flexible	

If condensate forming on the air supply collector is problematic, it must be insulated so that it is watertight.

Condensate drain

Because the flue gases condense in the discharge system, condensed water develops and must be discharged. As a rule of thumb, we anticipate a maximum of 1 litre of condensed water per m³ of natural gas consumed. In practice, this amounts to:

- Approx. 5 litre of condensate per hour for the Quinta Pro 45
- Approx. 7.5 litre of condensate per hour for the Quinta Pro 65
- Approx. 10 litre of condensate per hour for the Quinta Pro 90
- Approx. 12.5 litre of condensate per hour for the Quinta Pro 115

In addition to the condensate drain on each individual boiler, in the case of a joint flue gas discharge, an additional condensate collector must be placed at the bottom of the vertical duct. When using different materials, the condensed water must be discharged separately for each section in a single type of material. Discharge the condensed water directly into the drain using a syphon. Make an open connection with the drain. Condensed water must not be discharged into gutters: This prevents freezing and corrosion of the materials normally used for gutters. Horizontal sections in the flue gas discharge must slope down (5cm/m) towards the boilers. Fit the individual boilers to the joint flue gas discharge so that no condensate can flow back into the boilers.

Advantages at a glance

Quinta Pro boiler

- High efficiency: 110% NCV at 40/30°C (99% GCV)
- Boiler control:
 - a) Modulating (18-100%)
 - b) On/off
- Premix burner for clean combustion
- Low NO_x < 39mg/kWh
- Quiet operation < 48 dBA
- Digital display
- Data file for storing information
- Remote signalling options
- Cast aluminium heat exchanger
- Easy maintenance
- Built-in calorifier control
- Options for modular control and/or weather compensator
- Control 0-10V signal or volt free
- PC connection
- Advanced boiler control, Remeha's 'abc', for reliable heat delivery
- Conventional or "room-sealed" operation
- Cascade packages for up to 6 boilers
- Quick and easy installation
- Space saving
- For use with natural gas and L.P.G. (Some models require a conversion kit)

General description of Skid Mounted systems (Pre-assembled)

The Skid Mounted package is a complete pre-assembled unit and can be supplied in the following configuration:
Back-to-back or in line configuration (same price for either).

Maximum frame depth 650mm to allow access through a normal door (in line boilers only).

Boilers c/w individual shunt pumps.

Boxed steel tube frame (powder coated) complete with lifting eyes.

Wheeled frame for ease of movement within the plant room.

Fully adjustable legs for levelling after final positioning.

All associated pipe work and fittings, safety valves etc (Safety valves set at 3bar unless stated otherwise).

Boiler Skids designed to suit either 20 degrees or 11 delta T.

Flow and return connections to the system, BSP Thread or Flanged PN16 (left hand connections standard - right handed on request).

Gas connection Flanged PN16.

Condensate Terrain pipe work.

Midi-pressurisation unit c/w expansion vessel (supplied loose).

Lockable isolating switch for the power supply to each boiler.
6ltr Dosing pot.

Control panel with run and fail indicators for all boilers and pressurisation unit.

Volt free contacts for BMS interface within control panel.

Gas valve safety interlock via volt free contacts within control panel.

Description of pressurisation units used on the Skid Mounted Boilers

Automatic heating system pressure set c/w with high and low pressure switches. Supplied with a loose pressure vessel, sized to suit the kW rating of boilers at 5M static head and 3 bar operating pressure unless advised otherwise.

Combined nominal output (kW) at 81/70°C

No. of boilers	2	3	4	5	6
Quinta 45	80	120	160	200	240
Quinta 65	122	183	244	305	366
Quinta 90	168	252	336	420	504
Quinta 115	214	321	428	535	642

Note: Larger configurations available on request, please contact our technical help desk for further information.



Skid Mounted linear configuration - 2 boilers

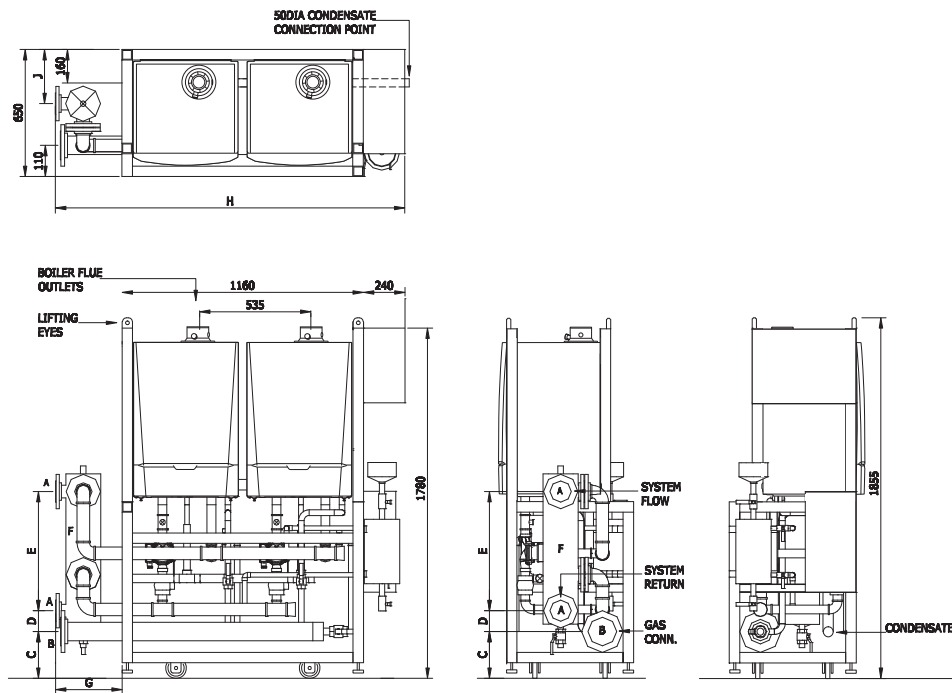

Note: Frame manufactured from fully welded Epoxy Powder Coated 40mmSQ. Box Section. Frame complete with Adjustable Feet for levelling requirement. All Flanges are PN16.

Dimensions (mm)

Config.	A	B	C	D	E	F	G	H	J
2xQ45	65 dia	50 dia	225	90	500	150 dia	320	1720	260
2xQ65	65 dia	50 dia	225	90	500	150 dia	320	1720	260
2xQ90	65 dia	50 dia	225	90	500	150 dia	320	1720	260
2xQ115	80 dia	50 dia	225	90	650	200 dia	350	1750	200

Skid Mounted linear configuration - 3 boilers

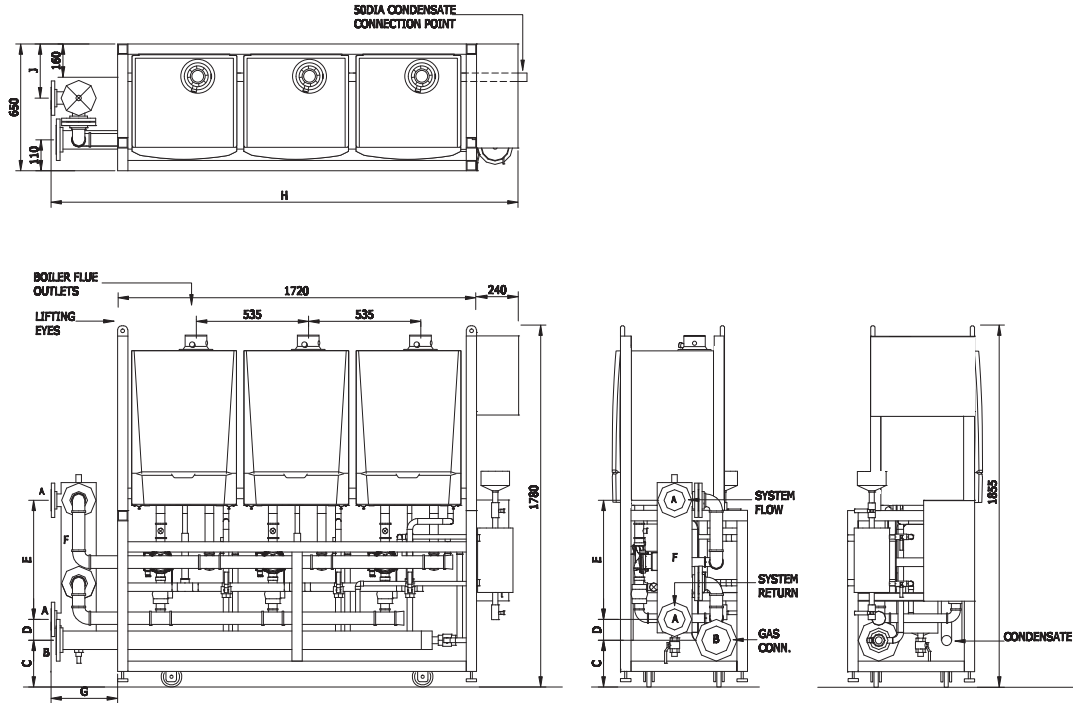

Note: Frame manufactured from fully welded Epoxy Powder Coated 40mmSQ. Box Section. Frame complete with Adjustable Feet for levelling requirement. All Flanges are PN16.

Dimensions (mm)

Config.	A	B	C	D	E	F	G	H	J
3xQ45	65 dia	50 dia	225	90	500	150 dia	320	2280	260
3xQ65	65 dia	50 dia	225	90	500	150 dia	320	2280	260
3xQ90	100 dia	65 dia	230	100	650	200 dia	350	2310	200
3xQ115	100 dia	65 dia	230	100	650	200 dia	350	2310	200

Skid Mounted back-to-back configuration - 4 boilers

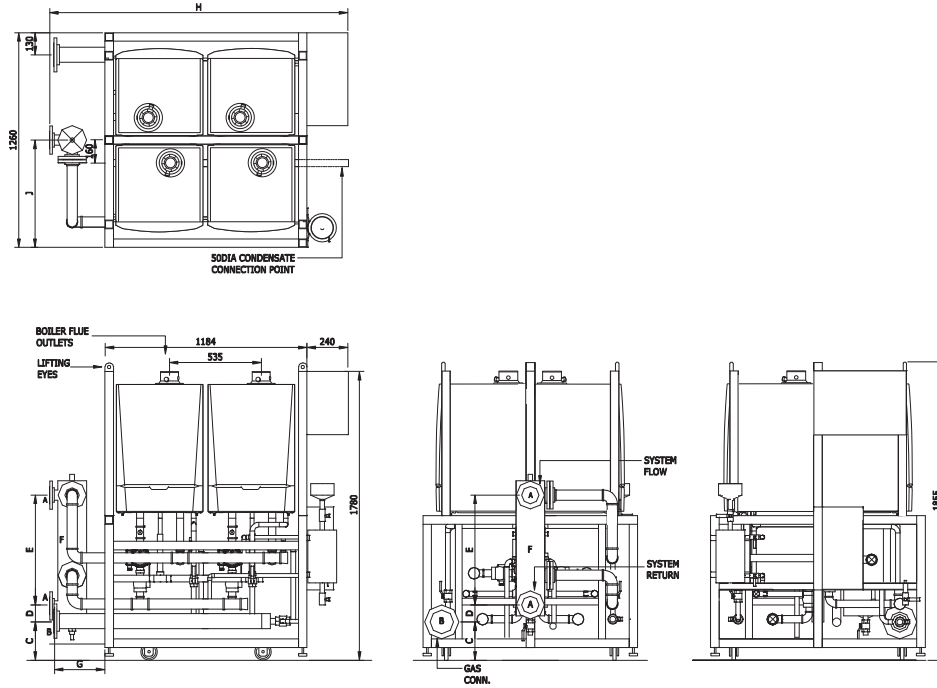

Note: Frame manufactured from fully welded Epoxy Powder Coated 40mmSQ. Box Section. Frame complete with Adjustable Feet for levelling requirement. All Flanges are PN16.

Dimensions (mm)

Config.	A	B	C	D	E	F	G	H	J
4xQ45	80 dia	50 dia	225	90	650	200 dia	350	1750	630
4xQ65	80 dia	65 dia	230	90	650	200 dia	350	1750	630
4xQ90	100 dia	65 dia	235	90	650	200 dia	350	1750	630
4xQ115	125 dia	80 dia	235	90	800	250 dia	375	1750	630

Skid Mounted back-to-back configuration - 6 boilers

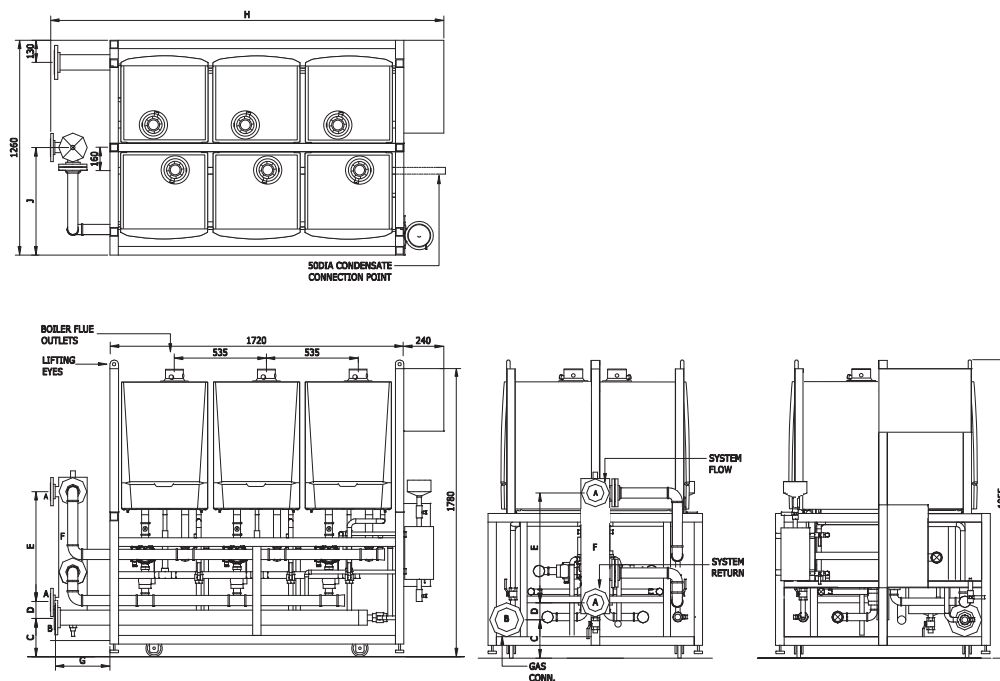

Note: Frame manufactured from fully welded Epoxy Powder Coated 40mmSQ. Box Section. Frame complete with Adjustable Feet for levelling requirement. All Flanges are PN16.

Dimensions (mm)

Config.	A	B	C	D	E	F	G	H	J
6xQ45	80 dia	65 dia	230	90	650	200 dia	350	2310	630
6xQ65	80 dia	65 dia	230	90	650	200 dia	350	2310	630
6xQ90	125 dia	80 dia	235	90	800	250 dia	375	2335	630
6xQ115	125 dia	80 dia	235	90	800	250 dia	375	2335	630

Flue gas table for combined flue discharge

Dimensioning flue gas discharge linear configuration

The following table is for dimensioning Cascade systems in a series configuration with the most frequently occurring combinations. The table runs from two to six units (in a linear or back-to-back configuration). For unit combinations not described here or a configuration that differs from the drawings, please consult our Sales Support department.

When compiling the tables, we assumed that the units would be switched on and off one by one and that there would be no elbows in the horizontal and vertical collector pipes.

Discharge system diameters: linear configuration, series connection, room ventilated operation

Heat output P kW	Boiler types	Ød=ØD(mm)			
		H=2-5m	H=5-9m	H=9-13m	H=13-17m
80	2xQ45	130	125	125	130
120	3xQ45	180	170	165	165
160	4xQ45	220	205	195	195
200	5xQ45	255	230	220	215
240	6xQ45	280	255	240	235
122	2xQ65	155	145	145	145
183	3xQ65	220	200	195	190
244	4xQ65	265	240	230	225
305	5xQ65	305	275	255	250
366	6xQ65	340	300	280	275
168	2xQ90	175	165	160	160
252	3xQ90	250	225	215	215
336	4xQ90	305	270	255	250
420	5xQ90	350	310	290	280
504	6xQ90	390	345	320	310
214	2xQ115	200	185	180	180
321	3xQ115	285	255	240	235
428	4xQ115	345	305	285	275
535	5xQ115	395	345	323	315
642	6xQ115	440	385	355	345

Note: Connect the boilers to the horizontal header using swept connections.

Linear configuration: series connection, room ventilated operation

(For conventional or open flue systems). Typical multi boiler installation with the flue combined into a single header and riser.

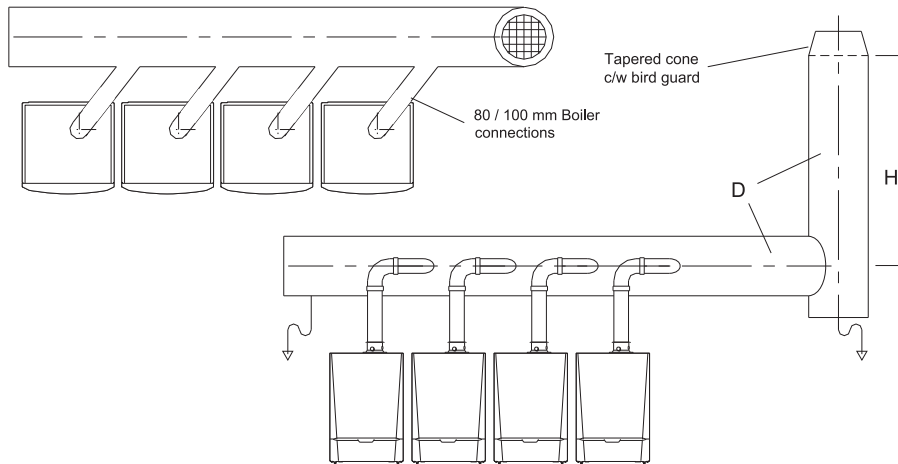

Flue gas discharge

Quinta Pro 30/45: 80mm Ø

Quinta Pro 65/90/115: 100mm Ø

Note 1: Using 90° boiler connections into the header may result in larger headers and risers being required. Other multi boiler flue combinations for the Quinta Pro 65, 90 and 115 may be available to suit different site conditions – for further information please consult your Area Sales Manager – contact details can be found on our web site www.remeha.co.uk

Note 2: Other flue configurations are possible, please contact our technical help desk for further information.

Quinta Pro 30, 45, 65, 90 and 115 - Multi or single boiler installation on a flue dilution system

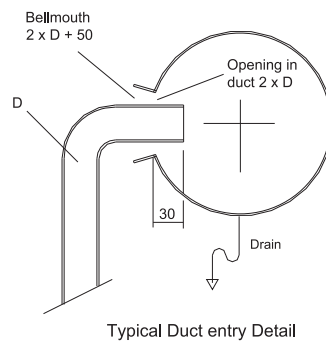
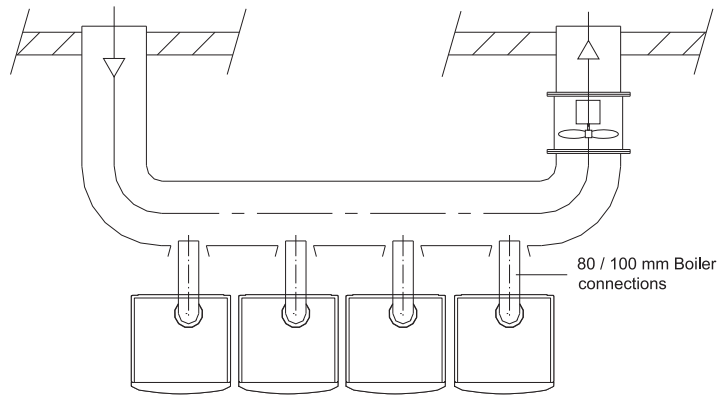

Note: Remeha is unable to offer a flue dilution system and recommends that the installer contacts a flue specialist to design and manufacture the system in accordance with the requirements of the British Standards and to comply with the guidelines illustrated above.

Typical multi boiler installation for a flue dilution flue system showing the flue break necessary for all pre-mix boilers to prevent the dilution fan affecting the gas/air ratio control system in the boiler.



TreadLightly

ON THE PLANET



Remeha Commercial Head Office

Remeha House
Molly Millars Lane
Wokingham
Berkshire RG41 2QP
T: 0118 978 3434
F: 0118 978 6977
E: boilers@remeha.com

www.remeha.co.uk

The data published in this technical sales leaflet is based on the latest information (at date of publication) and may be subject to revisions. It should be read in conjunction with our full technical brochure (available on request). We reserve the right to continuous development in both design and manufacture, therefore any changes to the technology employed may not be retrospective, nor may we be obliged to adjust earlier supplies accordingly. Issue 1 date: Jan 2011



PART OF BDR THERMEA



Remeha is committed to carbon offsetting