

ALBION

Aerocyl

Unvented Copper Hot Water Cylinders

IMPORTANT NOTE TO THE INSTALLER

The Albion Aerocyl Cylinder is specifically designed to be installed in conjunction with a Heat Pump, or a Solar thermal system and additional input from a Heat Pump. Connection to any other form of heat appliance or boiler is not acceptable.

Read these instructions before commencing installation. Unvented cylinders are a controlled service as defined in the latest edition of the building regulations and should only be fitted by a competent person.

The relevant regulations are: England and Wales – Building Regulation G3, Scotland – Technical Standard P5, N Ireland – Building Regulation P5

After installation the Benchmark Log Book must be completed and left, with these instructions, with the householder for future reference.



INSTALLATION INSTRUCTIONS FOR ALBION AEROCYL UNVENTED COPPER CYLINDERS: HEAT PUMP ONLY OR HEAT PUMP AND SOLAR INPUT MODELS

Issue 03 March 2011
Part No. BOOKAEROCYL



INTRODUCTION

The Aerocyl Unvented cylinder is made from Copper for excellent corrosion resistance. Aerocyl has a strong rust-proofed steel case and is highly insulated with environmentally friendly foam.

It is available in 5 capacities from 150 – 300 litres in Heat Pump Only versions. Solar input models are available in 4 capacities from 180 - 300 litres.

Aerocyl is supplied complete with all the necessary safety and control devices needed to connect to the cold water mains. All are pre-adjusted. High quality controls have been selected to combine high flow rate performance with minimum pressure drop to make Aerocyl perform well in all areas, even those with poor water pressure. Aerocyl is WRAS approved to show compliance with Building Regulations G3+L.

STORAGE PRIOR TO INSTALLATION

Aerocyl should be stored in its original packaging in an upright position in an area free from excessive damp.

UNPACKING THE UNIT



Expansion Vessel

150 ltr units - 12 ltr vessel
180, 210 & 250 ltr units - 19 ltr vessel
300 ltr units - 24 ltr vessel



15/22mm Tundish

AEROCYL COMES COMPLETE WITH ALL THE FITTINGS YOU NEED TO COMPLETE THE INSTALLATION:

Heat Pump Only Models

- Inlet control set.
- Temp & Pressure relief valve.
- 15mm / 22mm Tundish.
- Expansion vessel.
- Wall mounting bracket.
- Expansion vessel hose.
- 1 x 3kW Immersion Heater (2 x 3kW 240V on 250 & 300 litre units).
- Two port zone valve.
- Dual Thermostat.
- Installation & Maintenance Instructions.
- Benchmark Log Book.

Heat Pump and Solar Input Models

- Inlet Control set.
- Temp & Pressure relief valve.
- 15mm / 22mm Tundish.
- Expansion vessel.
- Wall mounting bracket.
- Expansion vessel hose.
- Immersion Heater.(2 x 3kW 240V on 250 & 300 litre units).
- 2 x Two port valves.
- 1 x Dual Thermostat.
- 1 x Single Control stat.
- 1 x Single High limit stat.
- Installation & Maintenance Instructions.
- Benchmark Log Book.
- 2 x Sensor pocket retaining bungs.



Expansion Vessel Hose



Wall Mounting Kit for Expansion Vessel



Temperature and Pressure Relief Valve



Dual Thermostat



High Flow Rate Inlet Control Set



Two Port Valve



Incoloy long life 240V x 3kW Immersion Heater



Installation & Maintenance Instructions



Benchmark Log Book

WATER SUPPLY

Aerocyl operates at 2.1 bar (controlled by the inlet control set) and is capable of delivering over 50 litres per minute. The high quality inlet control set has been designed to make the most of the flow rates available however the performance of any Unvented system is only as good as the mains water supply. The maximum possible water demand should be assessed taking into consideration that both hot and cold services are supplied simultaneously from the mains.

The water supply should be checked to ensure it can meet these requirements. If necessary consult the local water company regarding the likely pressure and flow rate availability.

If measuring the water pressure note that a high static (no flow) mains pressure is no guarantee of good flow availability. In a domestic installation 1.5 bar and 25 l/min. should be regarded as the minimum. The maximum mains pressure the inlet control set can cope with is 12 bar.

Consideration should be given to upgrading existing ½" (15mm) cold mains pipework to a larger size if the recommended minimum pressure/flowrate is not being achieved.

SITING THE UNIT

Aerocyl can supply outlets above it or at some distance from it. Site the unit to minimise "dead leg" distances especially to the point of most frequent use.

Outlets above the Aerocyl will reduce the outlet pressure available by 0.1 bar for every 1m of height difference. The unit should be protected from frost. Particular care is needed if siting in a garage or outbuilding. All exposed pipework should be insulated. Aerocyl must be installed VERTICALLY on a flat base capable of supporting the weight of the cylinder when full (see technical specification section for weights p14). The minimum recommended cupboard size is 650mm square.

Access for maintenance of the valves should be considered. Consideration should be given to position of discharge pipes (tundish), drain valves, motorised valves, shall be positioned away from electrical components. The immersion heaters are 375mm long and care should be taken that they can be withdrawn for servicing if required. The discharge pipework from the safety valves should fall continuously and terminate safely.

SCHEMATIC DIAGRAM

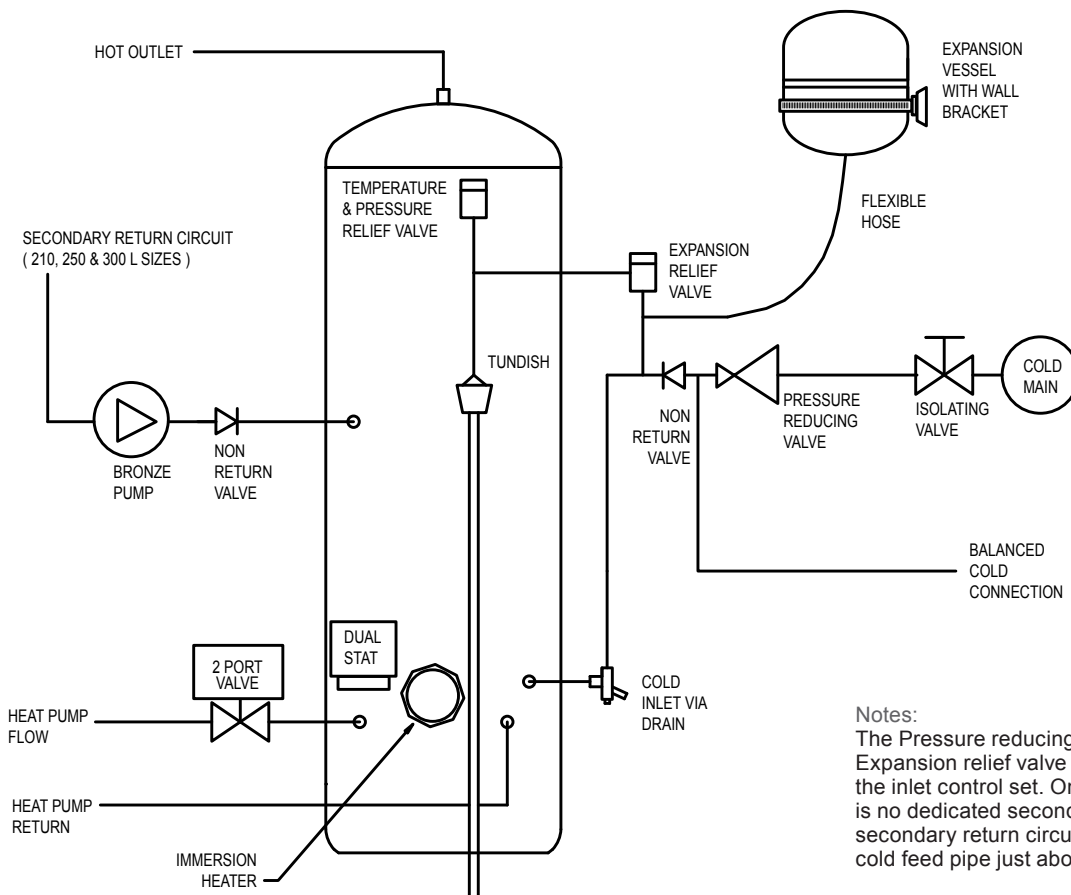

Notes:
The Pressure reducing valve, Non return valve and Expansion relief valve are combined together in the inlet control set. On 150 – 180 litre sizes there is no dedicated secondary return boss and the secondary return circuit should be tee'd into the cold feed pipe just above the drain elbow

GENERAL INSTALLATION

COLD MAINS PIPEWORK

Run the cold main through the building to the place where the Aerocyl is to be installed. Take care not to run the cold pipe near hot water or heating pipe work so that the heat pick-up is minimized. Identify the cold water supply pipe and fit an isolating valve (not supplied) A 22mm BS1010 stopcock can typically be used but a 22mm quarter turn full bore valve would be better as it does not restrict the flow as much. Do not use "screwdriver slot" or similar valves. Make the connection to the cold feed of the cylinder and incorporate a drain valve. Position drain valve no higher than the cold inlet to ensure sufficient draining of cylinder when required. Position the inlet control just ABOVE the Temperature & Pressure Relief Valve (TPRV) mounted on the side of the cylinder. This ensures that the cylinder does not have to be drained down in order to service the inlet control set. Ensure that the arrow points in the direction of the water flow. Select a suitable position for the expansion vessel. Mount it to the wall using the bracket provided. Use the hose to connect to the inlet control group.



(expansion vessel not to scale)

CONNECTING TO THE CYLINDER

All of the pipework connections on the cylinder are 22mm compression and supplied complete with gland nuts and olives, in the Accessory Kit Box. Only connect 22mm Table X copper tube to these connections.

Cut the tube with a pipe cutter and ensure no sharp edges or burrs protrude. Slide both gland nut and olive onto the tube and push tube fully home into the connection, ensuring the tube end fully bottoms on the connection recess.

Smear the outer wall of the olive with plumbing paste and tighten gland nut in the prescribed manner. Upon filling/commissioning, ensure all connections are completely watertight. **Note: No control or isolation valve should be fitted between the expansion relief valve and the storage cylinder. The relief valve connections should not be used for any other purpose.**

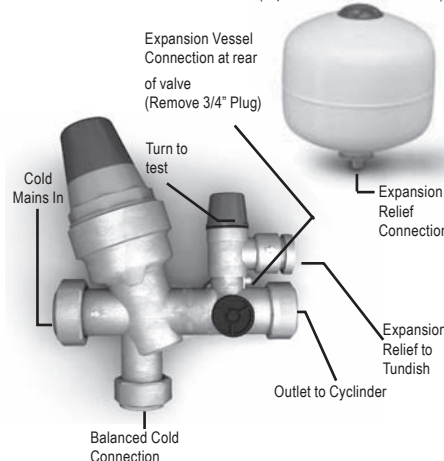

BALANCED COLD CONNECTION

If there are to be showers, bidets or monobloc taps in the installation then a balanced cold supply is necessary. There is a 22mm balanced connection on the inlet control set.

HOT WATER PIPEWORK

Run the first part of the hot water distribution pipework in 22mm. This can be reduced to 15mm and 10mm as appropriate for the type of tap etc. Your aim should be to reduce the volume of the hot draw off pipework to a practical minimum so that the time taken for the hot water is as quick as possible. Where monobloc mixing taps and showers are used, these should be installed to comply with the Water Supply (Water Fittings) Regulation 1999. If these devices are supplied with un-balanced supplies there should be single check valves installed at both inlets, to stop over pressurising of either supply. Select a suitable position for the expansion vessel. Mount it to the wall using the bracket provided and connect to the inlet control set with the flexible hose provided. Ensure that the top of the vessel is accessible for servicing.

PRIMARY COIL CONNECTIONS

For Solar input models refer to pages 10-13 before making any connections.

Connect the primary connections using the compression connections provided. The primary circuit must be positively pumped. Gravity circulation is not suitable. Either primary connection may be used as the primary flow. Reheat times are identical either way. The primary circuit can be open vented or sealed with up to a maximum pressure of 3.5 bar. If you seal the primary circuit an additional expansion vessel and safety valve is required. The Heat Pump must operate under effective thermostatic control. Uncontrolled heat sources are NOT SUITABLE. Please contact our technical department for guidance. Connect the two port zone valve into the primary flow pipework. The direction of flow arrow should be towards the primary flow connection. On twin coil solar input cylinders we have provided an extra thermostat boss should you wish to use it.

SECONDARY CIRCULATION

Aerocyl can be used with secondary circulation. An appropriate WRAS approved bronze circulator should be used in conjunction with a non return valve to prevent backflow. On large secondary circulation systems it may be necessary to incorporate an extra expansion vessel into the circuit to accommodate the increased system water volume.

A secondary return boss is fitted as standard on 210, 250 & 300L. On smaller sizes tee into the cold feed pipe above the drain.

IMMERSION HEATERS

Only immersion heaters with a thermal cutout may be used. To help ensure this the immersion heaters have a special 2 1/4" BSP thread. They are rated at 3 kW at 240 V and are of a low noise Incoloy construction. They have both a thermostat and a high limit cutout. Please order the correct replacement via ourselves, fitting non-approved immersions may affect your guarantee. When fitting, ensure the 'O' ring is positioned correctly on the head of the immersion heater and lubricate before fitting. Fit it by hand until almost home then tighten gently as the 'O' rings will seal easily. The electrical supply to each immersion heaters must be fused at 13A via a double pole isolating switch to BS 3456. The cable must be at least 2.5mm² heat resistant (85°C HOFRR) sheathed flex complying to BS 6141:1981 Table 8. Do not operate the immersion heater/s until the unit is full of water. Do not operate the immersion heater/s if any sterilisation liquid is in the cylinder as this will cause premature failure. Fit the immersion thermostat into the thermostat pocket. Complete the wiring – use the appropriate wiring diagrams on page 6.

DISCHARGE ARRANGEMENT

Diagram of a typical discharge pipe arrangement (extract from Building Regulation G3)

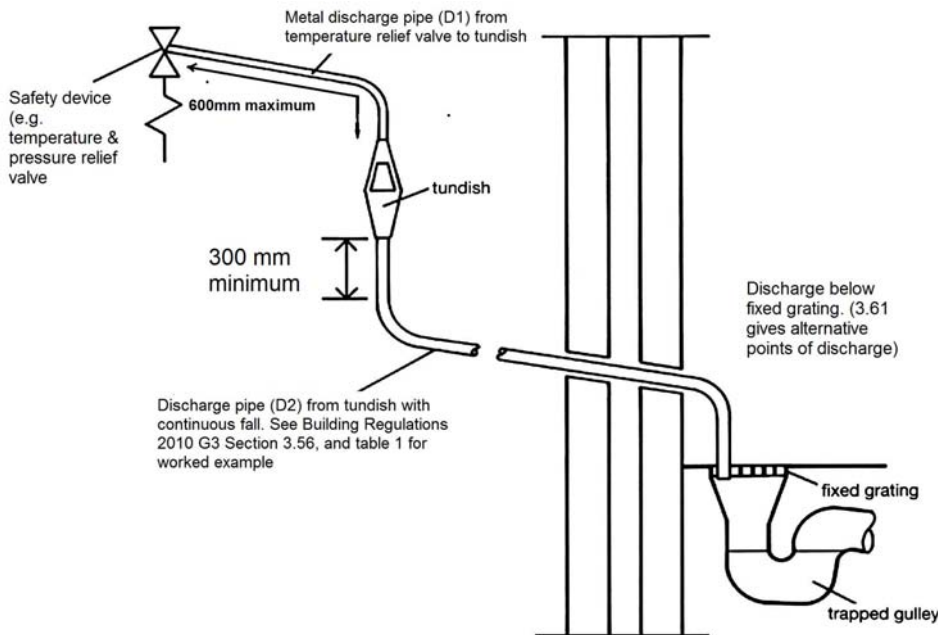

Note: The discharge will consist of scalding water and steam. Asphalt, roofing felt and non-metallic rainwater goods may be damaged by such discharges.

Note: D2 pipe from tundish is now allowed to be installed in soil stacks within premises. This activity is not recommended by Kingspan as discharge from T&P may continue for long periods of time. It is the installers responsibility to ensure the discharge pipework can support the discharge for prolonged periods. If used follow guidance on mechanical seal without water trap given in G3 Building Regulations. As discharge can be in excess of 90°C discharge into plastic pipework is also not recommended.

Position the inlet control group so that the discharge from both safety valves can be joined together via a 15mm end feed Tee (see diagram above). Connect the Tundish and route the discharge pipe. The discharge pipework must be routed in accordance with Part G3 of schedule 1 of the Building Regulations. The information that follows is not exhaustive and if you are in doubt you should seek advice. The two safety valves will only discharge water under fault conditions. When operating normally water will not be discharged. The tundish should be vertical, located in the same space as the unvented hot water storage system and be fitted as close as possible to, and lower than, the safety device, with no more than 600mm of pipe between the valve outlet and the tundish.

Any Discharge should be visible at the tundish. The tundish should be located such that any discharge is visible. In addition, where discharges from safety devices may not be apparent, e.g. people with impaired vision or mobility, consideration should be given to the installation of a suitable safety device to warn when discharge takes place, e.g. electronically operated.

The discharge pipe (D2) from the tundish should:

- A) Have a vertical section of pipe at least 300mm long, below the tundish before any elbows or bends in the pipework.
- B) Be installed with a continuous fall of at least 1 in 200 thereafter.

The discharge pipe (D2) from the tundish should be of metal or other material that have been demonstrated to be capable of withstanding temperatures of the water discharged.

The discharge pipe (D2) should be at least one pipe size larger than the nominal outlet size of the safety device unless its total equivalent hydraulic resistance exceeds that of a straight pipe 9m long i.e. discharge pipes between 9m and 18m equivalent resistance length should be at least two sizes larger than the nominal outlet size of the safety device, between 18 and 27m at least 3 sizes larger, and so on. Bends must be taken into account in calculating the flow resistance. Refer to diagram 1, Table 1 and the worked example. An alternative approach for sizing discharge pipes would be to follow BS6700 Specification for design installation, testing and maintenance of services supplying water for domestic use within buildings and their curtilages.

The discharge pipe (D2) should terminate in a safe place where there is no risk to persons in the vicinity of the discharge. Examples of acceptable discharge arrangements are:

- a. To a trapped gully with the end of the pipe below the fixed grating and above the water seal.
- b. Downward discharges at a low level; i.e. up to 100mm above external surfaces such as car parks, hard standings, grassed areas etc. are acceptable providing that where children play or otherwise come into contact with discharges, a wire cage or similar guard is positioned to prevent contact whilst maintaining visibility.
- c. Discharges at a high level; e.g. in to metal hopper and metal down pipe with the end of the discharge pipe clearly visible or onto a roof capable of withstanding high temperature discharges of water and 3m from any plastic guttering systems that would collect such discharges.
- d. device to warn when discharge takes place.

WORKED EXAMPLE
 The example below is for G1/2 temperature relief valve with a discharge pipe (D2) having 4 No. elbows and length of 7m from the tundish to the point of discharge.
 From Table 1:
 Maximum resistance allowed for a straight length of 22mm copper discharge pipe (D2) from a G1/2 temperature relief valve is: 9.0m. Subtract the resistance for 4 No. 22mm elbows at 0.8m each = 3.2m. Therefore the maximum permitted length equates to: 5.8m. 5.8m is less than the actual length of 7m therefore calculate the next largest size. Maximum resistance allowed for a straight length of 28mm pipe (D2) from a G1/2 temperature relief valve equates to: 14m. As the actual length is 7m, a 28mm (D2) copper pipe will be satisfactory.

Table1
 Sizing of copper discharge pipe 'D2' for a temperature relief valve with a G1/2 outlet size (as supplied).

Size of discharge pipework	Maximum length of straight pipe (no bends or elbows)	Deduct the figure below from the maximum length for each bend or elbow in the discharge pipe
22mm	Up to 9m	0.8m
28mm	Up to 18m	1m
35mm	Up to 27m	1.4m

TYPICAL SCHEMATIC WIRING DIAGRAM

The diagrams shown relate to the components listed. Other components and other manufacturers' components may vary in their wiring requirements, particularly thermostats. Always refer to manufacturers' instructions which may override this detail in order to function correctly.

WIRING DIAGRAM 2 x TWO PORT ZONE VALVES (S-PLAN)

VARIANT DUAL THERMOSTAT WIRING

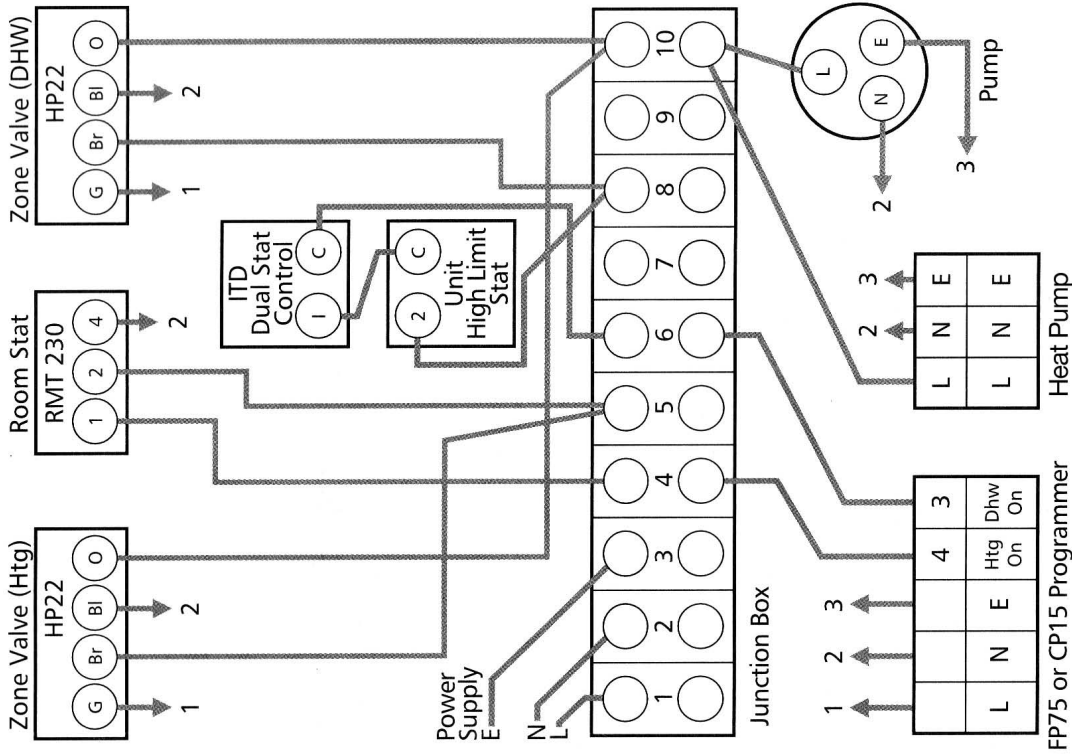

WIRING DIAGRAM THREE PORT MID POSITION VALVE (Y-PLAN) + TWO PORT VALVE

VARIANT DUAL THERMOSTAT WIRING

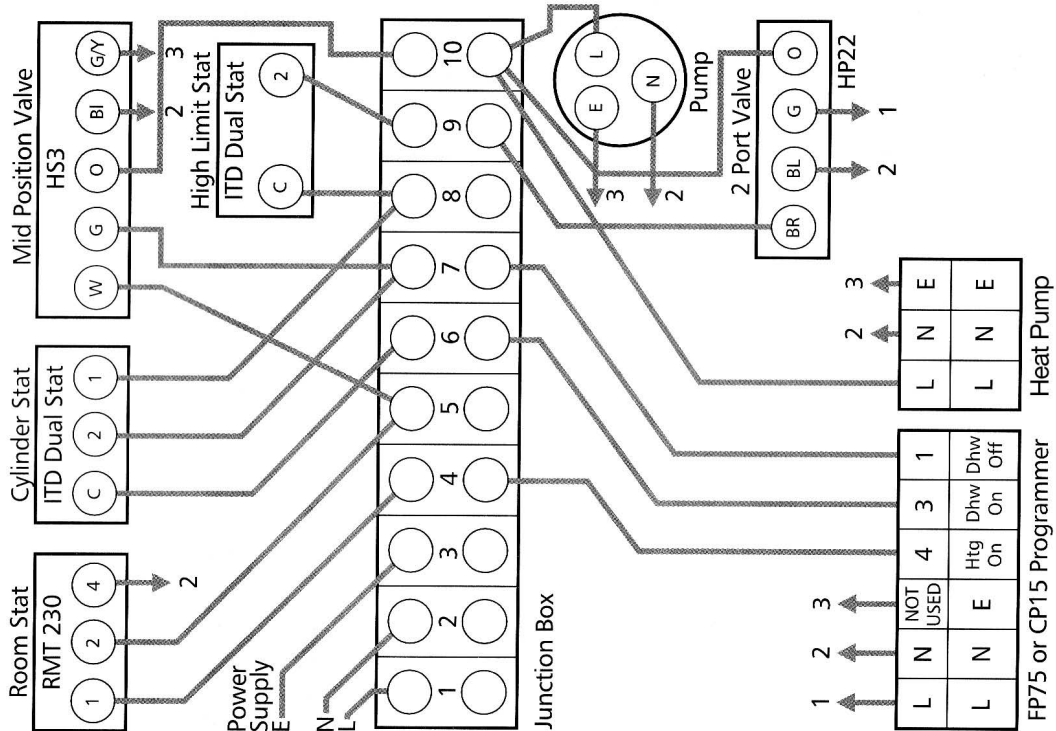

WHERE THE PROGRAMMER IS IN-BUILT TO THE HEAT PUMP REFER TO MANUFACTURERS WIRING DETAIL

COMMISSIONING

FLUSHING & FILLING THE CYLINDER

Check the pressure in the expansion vessel is 2.1 bar (30PSI), i.e. the same as the setting of the pressure reducing valve. The valve is of the car tyre (Schrader) type. Check all the connections for tightness including any factory made connections such as the immersion heater and the temperature and pressure relief valve. Before filling, open the hot tap furthest away from the Aerocyl to let air out. Open the cold main isolation valve and allow the unit to fill. When water flows from the tap allow it to run for a short while to flush through any dirt, swarf or flux residue. Close the tap and open every other hot tap in turn to purge all remaining air.

PRIMARY CIRCUIT

Consult the Heat Pump manufacturers commissioning instructions and fill the primary circuit. Ensure the lever on the two port valve is set to the filling position. When full, move the lever back. Switch the programmer to Domestic Hot Water (DHW) and allow the unit to start to heat. Adjust the dial of the dual thermostat to between 55°C and 65°C as required.

STORAGE TEMPERATURE

The recommended storage temperature is 60-65°C. In hard water areas consideration should be given to reducing this to 55°C. In many healthcare applications the guidance on Legionella control and safe water delivery temperatures will require storing the water at 60-65°C, distributing at 50- 55°C and using thermostatic mixing valves to control the final temperature. For details consult the NHS Estates Guidance on safe hot water temperatures.

SAFETY VALVE CHECKS

During heat-up there should have been no sign of water coming from either the expansion relief valve or the temperature / pressure relief valve. Now hold both of these safety valves fully open allowing as much water as possible to flow through the tundish. Check that your discharge pipework is free from debris and is carrying the water away to waste efficiently. Release the valves and check that they reseal properly. On completion of commissioning, fill in the Log book and leave with the house owner.

SERVICING

GENERAL

Servicing should only be carried out by competent installers and any spare parts used must be purchased from Albion. NEVER bypass any safety devices or operate the unit without them being fully operational.

DRAINING

Isolate from the electrical supply to prevent the immersion heaters burning out. Isolate the unit from the cold mains. Attach a hose to the draining tap ensuring it reaches to a level below the unit (This will ensure an efficient syphon is set up and the maximum amount of water is drained from the unit). Open the hot tap closest to the unit and open the draining tap. **WARNING: WATER DRAINED OFF MAY BE VERY HOT!**

ANNUAL MAINTENANCE

Aerocyl requires an annual service in order to ensure safe working and optimum performance. It is essential that the following checks are performed by a competent installer on an annual basis.

- 1) Twist the cap of the expansion relief valve on the inlet control set and allow water to flow for 5 seconds. Release and make sure it resets correctly. Repeat with the pressure / temperature relief valve. In both cases check that the discharge pipework is carrying the water away adequately. If not, check for blockages etc. and clear. **WARNING: THE WATER DISCHARGED MAY BE VERY HOT!**
- 2) Check that any immersion heaters fitted are working correctly and that they are controlling the water at a temperature between 55°C and 65°C.
- 3) Check the pressure in the expansion vessel is charged to 2.1 bar. Turn off the water supply to the unit and open a hot tap first. The air valve on expansion vessel is a Schrader (car tyre) type. Air or CO₂ may be used to charge the expansion vessel.
- 4) Unscrew the head on the inlet control set and clean the mesh filter within.
- 5) The Benchmark Log Book supplied with this unit should be updated at each service.

YOUR GUARANTEE MAY BE VOID WITHOUT PROOF OF ANNUAL SERVICING

SPARE PARTS

We carry the full range of spares listed below in stock. If you order before noon we will dispatch the same day for delivery the next to most locations. Tel: 01924 376026.

CONSETALT22 - Inlet control set (pressure reducing valve, strainer and expansion relief valve) 2.1 BAR/3 BAR.

VALVETP1/24 - Temperature & pressure relief valve 4 BAR/90°C

TUNDPL15ALT - Tundish

VALVE2PORT - 2 port valve

STATDUALALT - Dual thermostat

IMHTRANI - Immersion heater (same on all models)

EXPVES1221 - 12 litre Expansion Vessel (150 litre size)

EXPVES1921 - 19 Litre Expansion vessel (180 , 210 & 250 ltr sizes)

EXPVES2421 - 24 litre expansion vessel (300 ltr size)

EXPVBRKALTS - Wall mounting bracket

FLEXHOSEALT - Expansion vessel hose (¾" M x ¾" F)

STATSGLALT – Single control stat

STATHIGHALT – Single high limit stat

POCKETSSBUNG – Sensor pocket retaining bungs

FAULT FINDING

FAULT	POSSIBLE CAUSE	SOLUTION
Water escaping from the case.	Compression fitting on hot draw-off not sealing	Check/remake joint with sealing paste
Cold water at Hot taps	Heat Pump not working Motorised valve fault Cut-out in dual stat has operated	Check Heat Pump - Consult Heat Pump manufacturer's instructions Check plumbing / wiring to motorised valve Reset and investigate cause
Water discharges from expansion relief valve	If continual – pressure reducing valve (part of inlet control set) may not be operating correctly If continual – expansion relief valve seat may be damaged	Check outlet pressure from inlet control set is 2.1 bar. Remove cartridge – check seat and renew if necessary
Water discharges from temperature & pressure relief valve	If intermittent – expansion vessel charge may have reduced / bladder perished Unit is being back pressurised	Check pressure in expansion vessel. Recharge to 2.1 bar if necessary. If bladder perished replace vessel. With cylinder cold check pressure in cylinder. If this is the same as the incoming mains pressure then you are getting backfeed. Install a balanced cold supply (see page 4)
Milky / cloudy water	Unit has overheated – thermal controls have failed	Switch off power to immersion heaters, heat pump and solar controllers. Leave water supply on. Wait until discharge stops. Isolate water supply and replace if faulty.
No hot water flow	Oxygenated water Cold main off Strainer blocked in pressure reducing valve Inlet control set may be fitted incorrectly	Water from any pressurised system will release oxygen bubbles when flowing. The bubbles will settle out. Check and open stopcock Isolate water supply and clean Check and refit as required
Noise during hot water draw-off - typically worse in the morning.	Loose airing cupboard pipework	Install extra clips
Hot or warm water from cold tap	If tap runs cold after a minute or so the pipe is picking up heat from heating pipework.	Insulate / re-route

Technical Specifications

Aerocyl Heat Pump Only

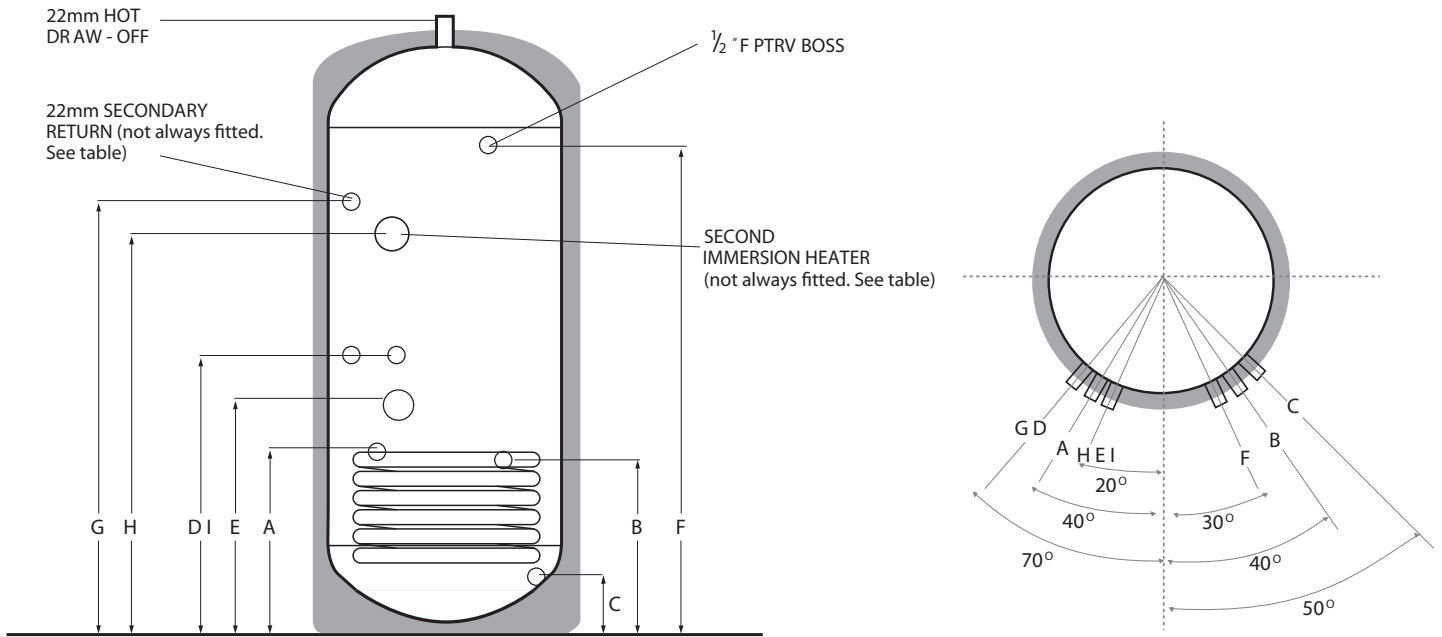

PRODUCT CODE	CAPACITY (Litres)	HEIGHT	DIAMETER	A	B	C	D	E	F	G	H
AAU150C	150	1128	550	450	425	135	650	515	863	N/F	N/F
AAU180C	180	1322	550	450	425	135	650	515	1057	N/F	N/F
AAU210C	210	1515	550	450	425	135	650	515	1250	1100	N/F
AAU250C	250	1772	550	450	425	135	650	515	1508	1350	1195
AAU300C	300	2096	550	450	425	135	650	515	1831	1706	1515

All dimensions are in mm and are of the cased unit. N/F = not fitted
 *kW rating of coil when tested in accordance with BS EN 12897

AEROCYL UNVENTED COPPER CYLINDER: SOLAR INPUT

These models are specifically designed to be installed with input from solar panels and the Heat Pump:

It is essential the overall installation meets all current legislation including, in particular, the high limit isolation requirements of Building Regulation G3. This document is designed to assist in achieving this aim.

UPPER COIL

The upper coil is connected to the Heat Pump as per the instructions on page 4, with the Danfoss ITD100 control and high limit thermostat inserted into pocket M (see diagram page 12). The wiring requirements are as depicted on page 11.

LOWER COIL

The lower coil is connected to the solar heat source. Either primary coil connection may be utilised as the flow or return. The solar cylinder sensor, supplied as part of the solar controls, inserts into pocket D (see page 12). It is necessary to mount the solar pump in the return pipework with the Danfoss HP22 two port valve (supplied with the cylinder) installed between the cylinder and the pump. This valve is of the powered open, sprung closed design and is wired through the ITC100 high limit stat which inserts into pocket J (see page 12). Two wiring options for high limit isolation are provided in Fig. 1 and Fig. 2 page 11. The Danfoss ITC100 control thermostat is not required in a solar installation but a control thermostat should be connected to the solar pump control device to stop circulation of the solar fluid. Refer to Solar installation guide for instructions on connections.

TYPICAL SCHEMATIC WIRING DIAGRAMS. SOLAR HIGH LIMIT CONTROL

These schematic wiring diagrams depict an IMIT high limit control stat and the connections are numbered accordingly. Where an alternative is supplied connect as per manufacturers' instructions.

Fig. 1 Isolation of Input: Closure of Two Port Valve

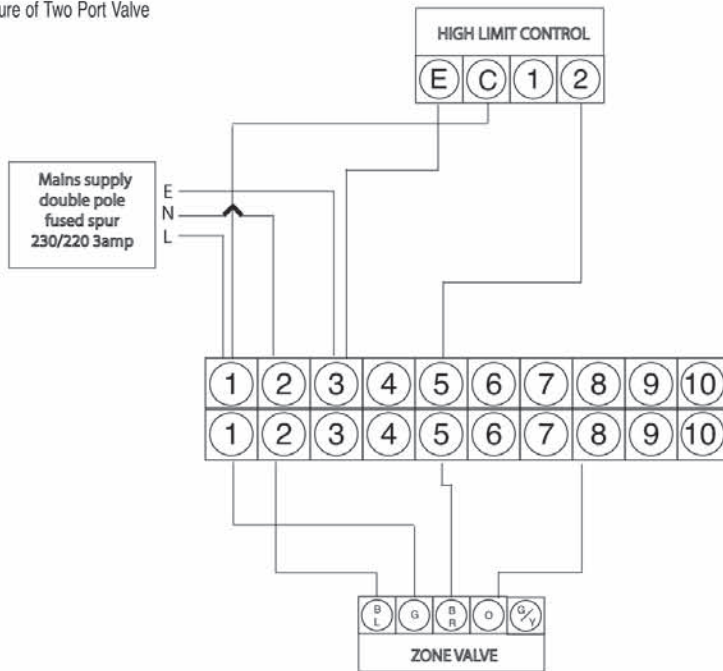
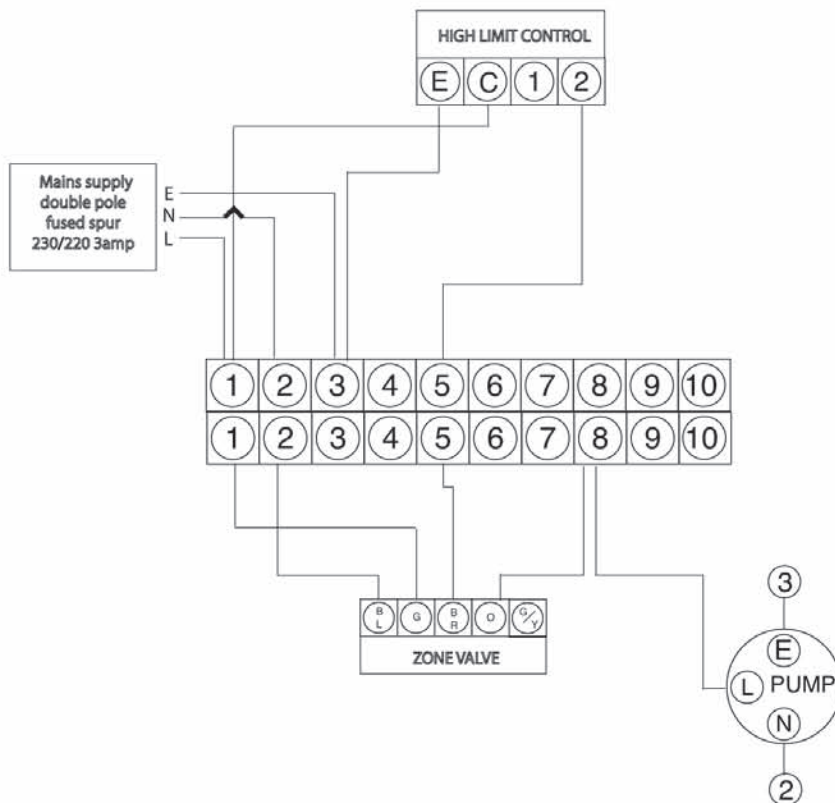
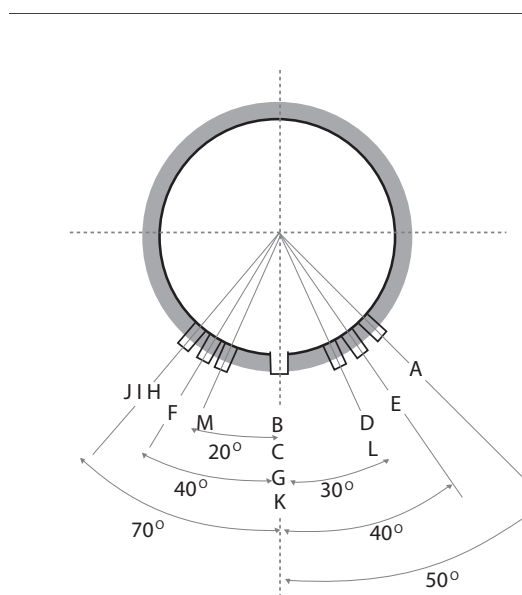
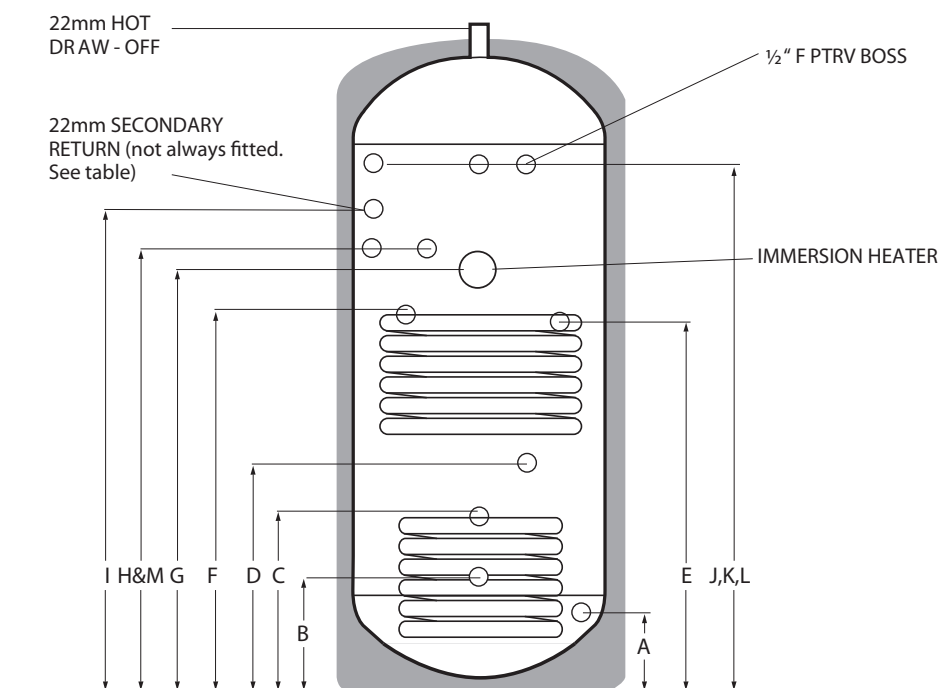

Fig. 2 Isolation of Input: Closure of Two Port Valve & Disconnection Pump



Technical Specifications

Aerocyl Heat Pump and Solar Input



PRODUCT CODE	CAPACITY (Litres)	HEIGHT	DIAMETER	A	B	C	D	E	F	G	H&M	I	JKL
AAUS180C	180	1322	550	135	225	335	355	840	865	915	955	N/F	1057
AAUS210C	210	1515	550	135	225	335	355	905	930	980	1020	1150	1250
AAUS250C	250	1772	550	135	225	335	355	1065	1090	1140	1180	1400	1507
AAUS300C	300	2096	550	135	225	335	355	1130	1155	1205	1245	1600	1830

All dimensions are in mm and are of the cased unit. N/F = not fitted

ALBION AEROCYL SOLAR INPUT CYLINDERS

Albion Aerocyl Solar input cylinders have been designed specifically with Solar applications complimenting the heat pump. Featuring a purpose-designed solar coil, which allows maximum heat transfer of solar energy into the stored water, the cylinders are suitable for use with a wide range of solar systems now available in the UK and are an efficient and environmentally friendly way of providing Domestic Hot Water. Aerocyl Solar input cylinders also offer the benefit of mains pressure hot water – powerful showers and fast filling baths.

Aerocyl Solar input cylinders are available in a range of capacities from 180 to 300 litres. They are manufactured from high grade Copper and come with a 5-year Guarantee on the inner container.

Aerocyl Solar input cylinders are designed to accept heat input from a renewable/sustainable (i.e: Solar) heat source. Where this input does not fully meet the desired temperature a guaranteed quantity of water can be heated to an acceptable temperature by the heat pump or immersion heater.

The Domestic Heating Compliance Guide document L1A and L1B provides excellent advice in sizing both cylinder designated solar areas and heat exchangers to the surface area of the solar collectors. Using this guide Albion are able to offer sizing advice for specification.

Water Capacities (litres)

Model	Designated Solar Area	Heat Pump Area	Total Capacity
AAUS 180C	55	125	180
AAUS 210C	65	145	210
AAUS 250C	90	160	250
AAUS 300C	100	200	300

Lower (Solar) Coil Specification

Model	Surface Area (m ²)	Fluid Content (litres)
AAUS 180C	0.963	2.355
AAUS 210C	0.963	2.355
AAUS 250C	0.963	2.355
AAUS 300C	0.963	2.355

NB: The total detail of compliance guide document should be consulted prior to specifying product or commencing design.

Insulation Detail

In addition our insulation process offers benefits to the 'green' specifier.
 Polyurethane foam, nominal thickness 50mm.
 The foam is CFC-Free and HCFC-Free.
 Ozone Depletion Potential (ODP) ZERO
 Global Warming Potential (GWP) ONE

TECHNICAL SPECIFICATIONS

PRESSURE SPECIFICATIONS	
Maximum Inlet Water Pressure	12 Bar
Operating Pressure	2.1 Bar
Expansion Valve Opening Pressure	3.0 Bar
Expansion Vessel Charge Pressure	2.1 Bar
Maximum Operating Pressure	3.0 Bar
Opening Pressure of T & P Valve	4.0 Bar
Opening Temperature of T & P Valve	90°C
Maximum Pressure on Primary Circuit (Heat pump & Solar Coil)	3.5 Bar

IMMERSION ELEMENT SPECIFICATIONS	
Element Rating	3kW 240 V
Thread Type	2 1/4" BSP
Fuse Requirement	13A via Double Pole Switch

CYLINDER DETAILS & PERFORMANCE SPECIFICATION												
PRODUCT CODE	WEIGHT EMPTY	WEIGHT FULL	CAPACITY	HEAT UP TIME	70% RE-HEAT TIME	HEAT PUMP COIL SURFACE AREA	HEAT PUMP COIL CAPACITY	HEAT PUMP COIL KW RATING	SOLAR COIL SURFACE AREA	SOLAR COIL CAPACITY	SOLAR COIL KW RATING	Heat Loss (kW/24Hr)
AAU150C	57	207	150 Ltr	19m12s	15m40s	2.0m ²	1.81	23.3	----	----	----	1.38
AAU180C	61	241	180 Ltr	23m18s	17m06s	3.0m ²	2.27	28.3	----	----	----	1.63
AAU210C	64	274	210 Ltr	27m22s	19m18s	3.0m ²	2.27	28.1	----	----	----	1.90
AAU250C	77	327	250 Ltr	34m16s	23m25s	3.0m ²	2.27	27.4	----	----	----	2.21
AAU300C	93	393	300 Ltr	35m14s	26m10s	3.0m ²	2.27	26.7	----	----	----	2.43
AAUS180C	65	245	180 Ltr	14m35s	10m03s	3.0m ²	2.27	34.1	0.963	2.355	22.7	1.63
AAUS210C	68	278	210 Ltr	17m52s	12m24s	3.0m ²	2.27	31.9	0.963	2.355	21.5	1.90
AAUS250C	81	331	250 Ltr	20m08s	14m42s	3.0m ²	2.27	33.0	0.963	2.355	21.1	2.21
AAUS300C	97	397	300 Ltr	25m23s	17m15s	3.0m ²	2.27	33.6	0.963	2.355	20.5	2.43

GUARANTEE

The Aerocyl's Copper vessel carries a 5-year guarantee against faulty materials or manufacture provided that:

- It has been correctly installed as per this document and all the relevant standards, regulations and codes of practice in force at the time.
- It has not been modified in any way, other than by Albion.
- It has not been misused, tampered with or subjected to neglect.
- It has only been used for the storage of potable water.
- It has not been subjected to frost damage.
- The unit has been serviced annually.
- The Benchmark Log Book has been filled in after each annual service.
- The guarantee period starts from the date of purchase and no registration is required.
- The system is fed from a public water supply.

Please note that invoices for servicing may be requested to prove that the unit has been serviced annually.

All the components fitted to / or supplied with the Aerocyl carry a 2-year guarantee.

EXCLUSIONS - THE GUARANTEE DOES NOT COVER

The effects of scale build up.

Any labour charges associated with replacing the unit or its parts. Any consequential losses caused by the failure or malfunction of the unit.

GUIDANCE IN THE EVENT OF A PROBLEM

If you have a problem in the first year contact the plumber who fitted the unit. Thereafter contact the plumber who carries out the annual servicing for you. If your Aerocyl develops a leak we will supply you with a new one. We ask for an nominal up-front payment to prevent fraud. We will require the original unit to be returned to us for inspection along with a copy of your Benchmark Log Book. If it is confirmed that it has failed within the terms of the warranty your up-front payment will be refunded.

If a component part fails within the 2-year guarantee period we will send you a new one without any up-front charge. Credit card details may be taken to prevent fraud. We ask you to post the faulty part back to us within one month by recorded delivery.

If you do not return the part we will charge you for it and for the postage and packing. If your part fails after two years service, we will ask for up-front payment.

USER INSTRUCTIONS

Your cylinder is automatic in normal use and requires only annual servicing. You should employ a competent installer to perform the annual servicing.

IF WATER IS FLOWING FROM THE SAFETY VALVES THROUGH THE TUNDISH THIS INDICATES A FAULT CONDITION AND ACTION IS NEEDED.

If this water is hot turn the Heat Pump, Solar controller and / or the immersion heater off. Do not turn off the water until the discharge runs cool. The discharge may also stop.

CALL A COMPETENT PLUMBER OUT TO SERVICE THE UNIT.

Tell them you have a fault on an unvented cylinder. We stock all the spare parts they may need (see page 7).

ALBION IS A MARKET LEADER IN THE MANUFACTURE AND SUPPLY OF QUALITY HOT WATER SYSTEMS.

Specification summary...

Materials

Inner shell - Copper
Coil - 22mm Diameter Copper
Bosses - Copper
Every Aerocyl cylinder is water tested to a pressure of 4.5 bar.

Insulation

Polyurethane foam, nominal thickness 50mm.
The foam is CFC-Free and HCFC-Free.
The foam has an Ozone Depletion Potential of Zero and a Global Warming Potential of One.

Casework

Zintec corrosion proofed steels throughout
Durable, stove enamelled gloss white paint finish outer casing.

Anode

None fitted/none required

Expansion Vessel

12 Litre size with 150 Litre models
19 Litre size with 180, 210 and 250 Litre models
24 Litre size with 300 Litre models

Control Settings

Pressure Reducing Valve - 2.1 Bar
Expansion Relief Valve - 3 Bar
Pressure and Temperature Relief Valve - 4 Bar/90°C
High Limit Thermostat in Dual Thermostat - 85°C
High Limit Thermostat in Immersion Heater - 85°C

Immersion Heater

2¼" BSP Parallel Threaded Head
Long Life Incoloy Sheathed Low Noise Element 14" Long
Long Life Incoloy Sheathed Thermostat Pocket 11" Long
Brazed Construction
Combined Thermostat and Safety Cut-Out
Element Rating 3kW at 240V A/C

Approvals

KIWA Approved to Building Regulations G3 & L
CE Compliant and fitted with a BEAB Approved
Immersion Heater

Albion Water Heaters, part of Kingspan Group, is a major manufacturer of Domestic Hot Water storage systems in the UK and offers the trade products backed by the service and technical development skills that only a company of its size can.

All sites are licensed to British Standards quality assurance BS EN ISO 9001 : 2008 and Albion is a BSi registered firm. This means that all manufacturing plants are monitored by an independent inspectorate and the quality systems employed by Albion meet the stringent requirements set down.

Specifiers, stockists and users can depend on Albion for consistent quality and supply. Albion continues to develop energy saving and innovative hot water products for domestic and commercial applications.

Contact information:

Albion Water Heaters, Station Rd, Caythorpe, Grantham, Lincs, NG32 3EW



OHSAS 18001

Kingspan Renewables have a policy of continuous product development and may introduce product modifications from time to time. As a consequence details given in this brochure are subject to alteration without notice.

Page 16 of 16

Albion
Exceeding the Standard

Albion Water Heaters
Station Road, Caythorpe, Nr. Grantham, Lincolnshire NG32 3EW
T: 01400 272726 F: 01400 273508
Technical Helpline: 0845 260 7260 Technical Faxline: 0845 260 7261
www.albionwaterheaters.com
www.kingspanhws.com

Kingspan
Renewables